

Project \_\_\_\_\_  
 Item \_\_\_\_\_  
 Quantity \_\_\_\_\_  
 CSI Section 11400  
 Approved \_\_\_\_\_  
 Date \_\_\_\_\_

# QuietQube® RNF-2000C

Remote Nugget Ice Machine

Models - 60Hz

RNF-2000C



RNF-2000C Remote Nugget Ice Machine



RCUF-2200C Condensing Unit



RNF-2000C Remote Nugget Ice Machine on D570 Bin

QuietQube® Series Remote System consists of a remote condensing unit, interconnecting refrigerant lines, ice machine head section, and ice storage unit--All ordered separately. QuietQube ice machine with RCUF condensing unit is designed as a Manitowoc system and not for use with any other ice machine or remote condenser brand.

- Up to 1,915 lbs (868 kg) daily ice production.
- Only 30" (76.2 cm) wide.
- Evaporator is designed for maximum quality and operating life.
- Remote, air-cooled condenser system improves efficiency and ice production, conserving energy. Manitowoc remote condenser systems effectively dissipate heat at a convenient location, indoors or outdoors, away from the ice machine. This maximizes icemaking capability and minimizes air conditioning loads by lowering the ambient air temperature at the ice machine.
- Quiet operation eliminates most noise from the refrigeration system. Promotes a relaxing atmosphere.
- Ice machine is lighter in weight to simplify installation.
- Stainless steel exterior has a clean and modern look to enhance the display in any self-serve environment.

COMMERCIAL WARRANTY		
ICE MAKER	EVAPORATOR	COMPRESSOR
<b>3</b> YEAR PARTS AND LABOR	<b>5</b> YEAR	<b>5</b> YEAR PARTS 3 YEAR LABOR

## Ice Shape

Nugget ice consists of small pieces ranging from 3/8" to 1/2" in width and length. Offers a 85% ice to water ratio with a soft, chewable texture while still providing maximum cooling and great dispensability.



Ice shown actual size



QuietQube® RNF-2000C



## RNF-2000C Ice Machine

### Ice Machine Electric

208-230/60/1

**Minimum Circuit Ampacity:** 3.2

**Max. fuse size:** 15 amps

The ice machine and condensing unit are powered independently of each other. HACR-type circuit breakers can be used in place of fuses.

### Specifications

**Refrigerant:** R404A

**Operating Limits:**

- Ambient Temperature Range: 50°-110°F (10°-43°C)
- Water Temperature Range: 37°-90°F (3°-32°C)
- Water Pressure
- Ice Maker
- Water In:
  - Min. 14 psi (96.5 kPa)
  - Max. 80 psi (551.1 kPa)

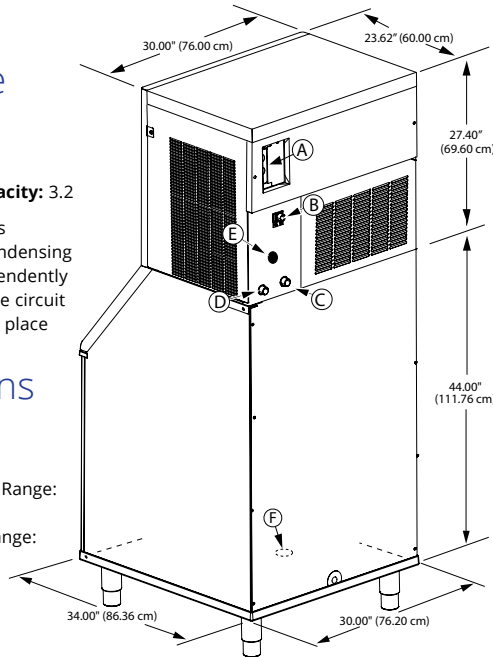

**Shipping Weight:**  
279 lbs. / 126.8 kgs.

- Ⓐ Electrical Entrance (2) Options
- Air-Cooled Units:**
  - Ⓑ 3/8\" F.P.T. Ice Making Water Inlet
  - Ⓒ 1/2\" M.P.T. Ice Making Water Drain
- Water-Cooled Unit Option:**
  - Ⓓ 3/8\" F.P.T. Condenser Inlet
  - Ⓔ 1/2\" M.P.T. Condenser Drain
  - Ⓚ 1/2\" M.P.T. Ice Making Water Drain
  - Ⓛ 3/8\" F.P.T. Ice Making Water Inlet
  - Ⓜ 3/4\" F.P.T. Bin Drain

Bin	Adapter
D-970	K-00470
F-1325/1650	K-603030
FC-1350	K-613030

## RCUF-2200 Condensing Unit

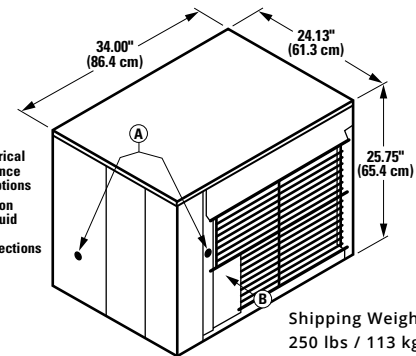

**Shipping Weight:**  
250 lbs / 113 kg

### Condensing Unit Electric

208-230/60/3 standard.

Note: QuietQube ice machine is wired independent of condensing unit.

Min. circuit ampacity: 15 3ph

Max. fuse size: 15 3ph

BTU Per Hour: 15,700 (average)

Compressor: Nominal rating: 3 HP

**Operating Limits:**

Ambient Temperature Range: -20° to 120°F (-29° to 49°C)

**Installation Information and Dimensions:**

Maximum Line Length—100' (30.5 m)\*

Maximum Vertical Rise\*—35' (10.7 m) above ice machine.

Maximum Vertical Drop—15' (4.5 m) below ice machine.

\*A rise over 20' (6 m) requires S-Trap Kit K-00172 - ordered separately

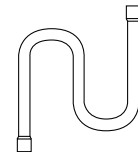

QuietQube® RNF-2000C

### Standard Interconnecting Tubing

Model	Line Length		Weight	
	ft.	m.	lbs.	kgs
RC-51	50	15.2	27	12

### Remote Air-cooled Ice Machine

Model	Ice Shape	Ice Production 24 Hours		Power Usage 90°Air/ 70°F Water 32°Air/21°C Water	Potable Water Usage /100 lbs. 45.4 kgs. of Ice
		70°Air/ 50°F Water 21°Air/10°C Water	90°Air/ 70°F Water 32°Air/21°C Water		
RNF-2000C	Nugget	1915 lbs.	1475 lbs.	4.42	12 Gal. 45 L
		868 kgs	669 kgs		

Order ice storage bin separately. Will not accept AuCS accessory.

**Note:** Use K00488 ice level management kit on dispenser applications

Welbilt reserves the right to make changes to the design or specifications without prior notice.