







ADMIRAL VG (44") Single Tank Rack Conveyor Dishwasher

-  233 Racks Per Hour | 20" x 20"
-  Optional VaporGuard Ventless System
-  Dual Integrated & Submerged Booster
-  CrossFire Wash System

STANDARD FEATURES

- CrossFire Wash System
- Color-coded curtains
- Tank heat: integrated booster
- Heat and energy saving transfer system
- Manifold clean-out brush
- S/S 304 stainless steel construction
- Automatic tank fill
- Low water protection
- Detergent connection provision
- Elevated top mounted control panel
- Door safety switches
- Standard frame drip proof motors
- Override switch for de-liming
- SureFire Start-Up & Check-Out Service
- Ventilation fan connection provision

- End caps/pipe plugs secured to prevent loss
- VFD controlled continuous drive conveyor

ADD-ONS

- VaporGuard System
- Tank heat:
- Electric
- Steam coil
- Pressure reduction valve and line strainer
- Vent cowl collar with adjustable damper controls
- Security package
- Rack limit switch
- Power Loader
- Power Unloader
- Plastic 20" x 20" racks (plate or silver)
- Two point connection

SPECIFIER STATEMENT

Specified unit will be an Insinger Admiral 44 Advanced VG single tank, rack conveyor dishwasher with optional VaporGuard system. Features include VaporGuard condensation removal, CrossFire wash system, S/S 304 stainless steel construction, automatic tank fill, low water protection, elevated top mounted control panel, SureFire Start-Up & Check-Out service, and a VFD controlled continuous drive conveyor.



SPECIFICATIONS

Capacity	Racks Per Hour	234
	Dishes Per Hour	5225
	Meals Per Hour	200-400
Heating & Venting	Tank Heat	18 kW
	Booster Heat	29.4 kW
	Venting (Load End)	350 CFM
	Venting (Unload End)	350 CFM
Water	Water Inlet Temperature	110°F
	Water Consumption (20 PSI)	.06 gal/rack
	Wash Tank Capacity	33.75 gal
	Peak Drain Flow	9.0 gal/min
	VG Consumption (20 PSI)	4.0 gal/min
Other	Drive Motor HP	1/15
	Wash Motor HP	2.0
	Shipping Weight	900

ELECTRICAL

		E1	E2
Electrical Options (Dual Point)	208/60/3	57.5 amps	81.6 amps
	240/60/3	50.8 amps	70.7 amps
	480/60/3	26.0 amps	35.4 amps

PROJECT BUILD FORM

Project Name		
Project Manager		
	208/60/3	<input type="checkbox"/>
Voltage & Phase	240/60/3	<input type="checkbox"/>
	480/60/3	<input type="checkbox"/>
Direction	Left to Right	<input type="checkbox"/>
	Right to Left	<input type="checkbox"/>
Approval (Please Check One)	Approved	<input type="checkbox"/>
	Approved as Noted	<input type="checkbox"/>
	Rejected	<input type="checkbox"/>
Signature	Date	
Internal Info	Serial Number	
	Configuration Code	

TECHNICAL DRAWINGS

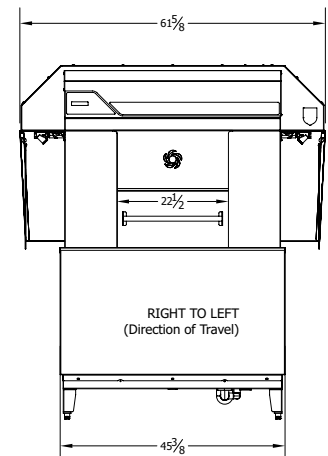
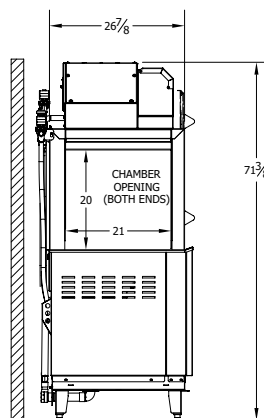
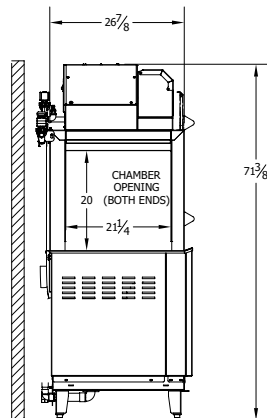
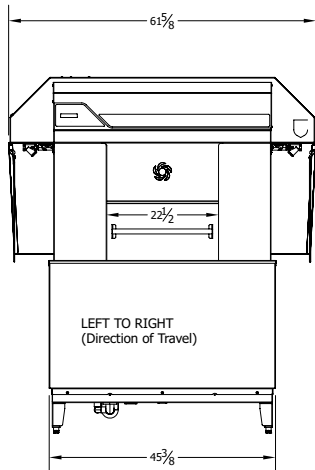
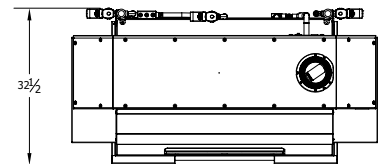
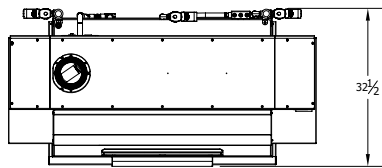

Contact Ininger Sales at 800-344-4802 for an installation drawing specific to your application.
 Note: Due to product improvement we reserve the right to change information and specifications without notice.