

TQ SUPREME CARTS SINGLE DOOR TRAY DELIVERY CARTS WITH TWO TRAYS PER SLIDE



Products on the picture are shown with the optional corner bumpers.

Item Numbers

DXSU2T1D10
DXSU2T1D12
DXSU2T1DPT10
DXSU2T1DPT12
DXSU2T1D16

Application

TQ Supreme is the newest edition to the line of totally quiet (TQ) carts. Here we offer you a cart that has a modular design and notable sound dampening construction where quiet is a needed commodity.

This equipment is intended for "Industrial Use Only"

Construction

TQ Supreme Cart single door tray delivery cart with a stainless steel and aluminum modular structure is NSF Listed. The cart has (standard) 5-1/4" tray height spacing with 2 trays per shelf for a total of 10 or 12 capacity for the cart. Comes with heat release vented from the top of the door. The cart has magnetic locking doors with noise suppression door bumpers and magnetic locking (open) door with door stop for noise reduction. The cart comes with an interchangeable rack system with adjustable sizing to accommodate for different tray sizes. The racks also have noise reduction gravity locking brackets with a press lever release mechanism.

The side panels of the cart are curved and have noise reduction brackets to prevent vibration while the cart is in motion.

The cart comes with 6" Quiet casters with noise suppression bearing covers, high temperature wash resistant noise dampening bearing grease, and caster isolation pads (2 rigid, 2 swivel with brakes).

Standard Features

- Sound dampening design
- Vertical and horizontal push handles – Full length recessed vertical push handle for hand protection and maneuverability
- Modular design with replaceable stainless steel panels
- 4 sided top to secure accessories such as condiment carrier, coffee urn, Coldmaster Coolcheck during delivery
- Fits 14" x 18" and 15" x 20" trays
- Standard 5-1/4" tray height spacing
- Features heat release from the front door
- Heavy Duty Stainless Steel base construction with full perimeter bumper
- Removable tray rack for easy cleaning
- Drain is standard
- Magnetic door lock to hold the door closed and open at 270°
- 6" Quiet casters with noise suppression bearing covers

Compatible Tray Sizes

- 14" x 18"
- 15" x 20"
- DXRST1520033

Warranty

One year parts and labor.

Standard Lead-time

From when the order has been entered to when it has been shipped

- 2 weeks for orders of 1 to 9 carts
- 4 weeks for orders of 10 carts or more

Lead-time Custom Graphics

From when the graphics have been approved by the customer to when the order has been shipped

- 5 weeks for orders of 1 to 9 carts
- 6 weeks for orders of 10 carts or more

TQ SUPREME QUIET SINGLE DOOR TRAY DELIVERY CARTS WITH TWO TRAYS PER SLIDE

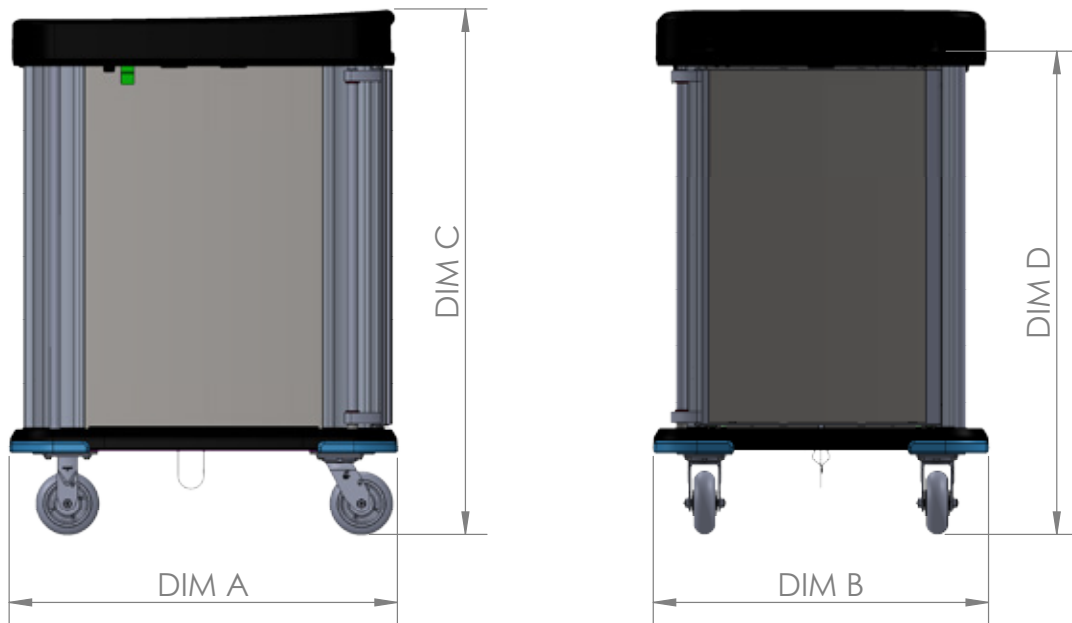

Items and Dimensions

| ITEM NUMBER | MODEL NUMBER | DEPTH A | LENGTH B | HEIGHT with top rail C | HEIGHT without top rail D | CASTERS | | SHIP WEIGHT | SHIP CUBE | TRAY CAPACITY |
|--------------|--------------|----------------------|----------------------|------------------------|---------------------------|--|------------------|--------------------|-----------|---------------|
| | | | | | | TYPE | DIAMETER | | | |
| DXSU2T1D10 | SU2T1D10 | 35.95" (91.31 cm) | 31.04" (78.84 cm) | 43.40" (110.23 cm) | 40.67" (103.30 cm) | 2 rigid, 2 swivel w/Tech lock brakes | 6" (15.24 cm) | 270 lb (122 kg) | 51.10 | 10 |
| DXSU2T1D12 | SU2T1D12 | 35.95" (91.31 cm) | 31.04" (78.84 cm) | 48.65" (123.57 cm) | 45.92 (116.6 cm) | 2 rigid, 2 swivel w/Tech lock brakes | 6" (15.24 cm) | 290 lb (130 kg) | 61.26 | 12 |
| DXSU2T1DPT10 | SU2T1DPT10 | 35.95" (91.31 cm) | 31.04" (78.84 cm) | 43.40" (110.23 cm) | 40.67" (103.30 cm) | 2 rigid, 2 swivel w/Tech lock brakes | 6" (15.24 cm) | 270 lb (122 kg) | 51.10 | 10 |
| DXSU2T1DPT12 | SU2T1DPT12 | 35.95" (91.31 cm) | 31.04" (78.84 cm) | 48.65" (123.57 cm) | 45.92 (116.6 cm) | 2 rigid, 2 swivel w/Tech lock brakes | 6" (15.24 cm) | 290 lb (130 kg) | 61.26 | 12 |
| DXSU2T1D16 | SU2T1D16 | 35.95" (91.31 cm) | 31.04" (78.84 cm) | 58.96" (149.75 cm) | 56.23" (142.82 cm) | 2 rigid, 2 swivel w/Tech lock brakes | 6" (15.24 cm) | 310 lb (140 kg) | 66.36 | 16 |

ALL CARTS ARE DESIGNED FOR THE FOLLOWING TRAY SIZES:

14" x 18", 15" x 20", DXRST152003

Standard Options Available

- **DXSUPQC48** 8" QUIET CASTERS
- **DXSUPSDL** SECONDARY DOOR LATCH/TRANSPORT LATCH
- **DXSUPCBWS** WALL SAVER BUMPERS
- SIGNATURE STS WOODGRAIN PANELS IN CHERRY, OAK, MAPLE
- SIGNATURE LOGO PANELS
- SIGNATURE CUSTOM PANELS
- SIGNATURE PEDIATRICS PANELS

Standard Accessories Available

- **CH0303** CONDIMENT CADDY 6EA PINT CONTAINERS
- **CH1503** CONDIMENT CADDY WITH 4EA PINT CONTAINERS
- **DXCM1100C1402** COLDMASTER COOLCHECK - FULL SIZE
- **DXCM1125** COLDMASTER COOLCHECK - FULL SIZE LID
- **DXCM1101C1402** COLDMASTER COOLCHECK - HALF-SIZE
- **DXCM1126** COLDMASTER COOLCHECK - HALF-SIZE
- **1060101** 12" X 18" SERVICE MAT BLACK

Signature Woodgrain panels

Add 10, 12, 10PT or 12 PT to the end of the item number below for the cart version selection

DXSUSMA: STS panels with Maple Woodgrain
DXSUSOA: STS panels with Oak Woodgrain
DXSUSCH: STS panels with Cherry Woodgrain

Contact your Sales Representative for more information on the available standard options.

Please confirm that you have the most current specification sheet by visiting www.dinex.com.

Dinex® reserves the right to change specifications and product design without notice.

Such revisions do not entitle the buyer to corresponding changes, improvements, additions or replacements for previously purchased equipment.



4711 E. Hefner Road
Oklahoma City, OK 73131
800.654.8210 | 405.475.5600
www.dinex.com