

## "OSE26F" OVERSHELVES - ECONOMY SERIES

### *Double Tier, 16GA w/Flat Top*

#### FEATURES:

- Stainless Steel Shelf With Stallion Safety Edge On Front And Rear
- 16GA, Type 300 Stainless Steel With #4 Polish, Satin Finish
- Uprights Are 1" O.D. Round 18GA Tubing, Type 300 Stainless Steel With #4 Polish, Satin Finish
- Rear Or Center Mount (Please Specify)
- Single Overshelves Are Mounted 18" Above Table Top
- Double Overshelves Are Mounted 12" Above First Shelf
- Overshelves Feature Knockdown Setup
- All Models Are Approved By The National Sanitation Foundation

#### SPECIFICATIONS:

- Stainless Steel Overshelves Are TIG Welded
- Exposed Welds Are Polished To Match Adjacent Surfaces
- Shelf: 16GA, Type 300 Stainless Steel, #4 Polish, Satin Finish
- Uprights: 1" Round O.D., 18GA Type 300 Tubular Stainless Steel #4 Polish, Satin Finish
- Heat Lamp Provision: OSEHLP-6XX 6=Width Of Provision, XX=Nominal Length Of Shelf

#### CERTIFICATIONS:



OSE26FK-1248

### "OSE26F" OVERSHELVES - ECONOMY SERIES

LENGTH (L)	12" WIDTH	WT (LBS)	18" WIDTH	WT (LBS)
36"	OSE26FK-1236	24	OSE26FK-1836	36
48"	OSE26FK-1248	31	OSE26FK-1848	44
60"	OSE26FK-1260	37	OSE26FK-1860	52
72"	OSE26FK-1272	43	OSE26FK-1872	55
84"	OSE26FK-1284	49	OSE26FK-1884	70
96"	OSE26FK-1296	55	OSE26FK-1896	80
108"	OSE26FK-12108	61	OSE26FK-18108	88
120"	OSE26FK-12120	71	OSE26FK-18120	98
132"	OSE26FK-12132	79	OSE26FK-18132	106
144"	OSE26FK-12144	89	OSE26FK-18144	114

ALL DIMENSIONS ARE TYPICAL. TOLERANCE +/- .500". JOHN BOOS & CO. RESERVES THE RIGHT TO CHANGE SPECIFICATIONS WITHOUT NOTICE.

# DETAILED SPECIFICATIONS

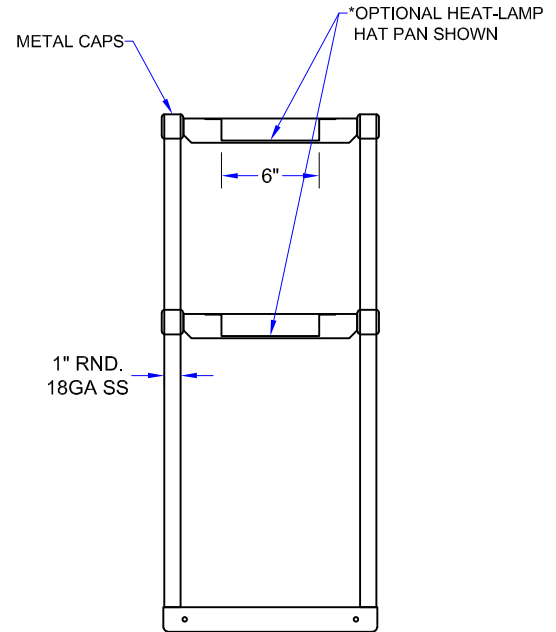
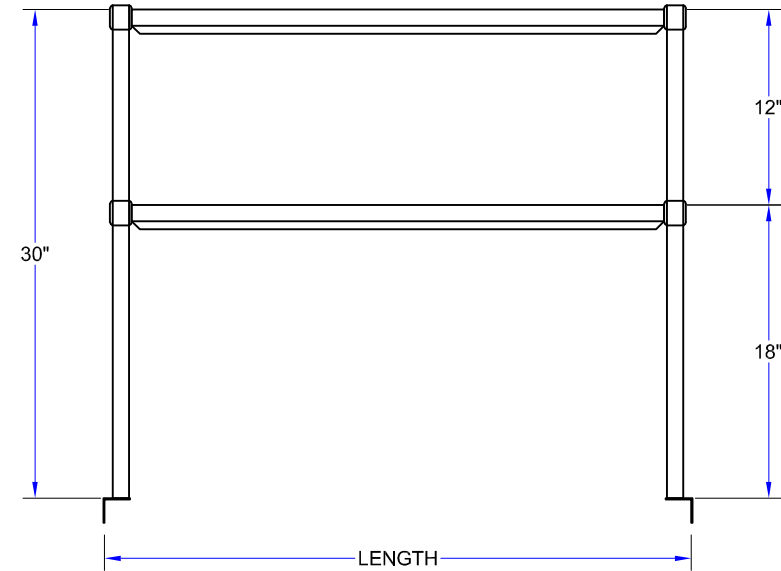
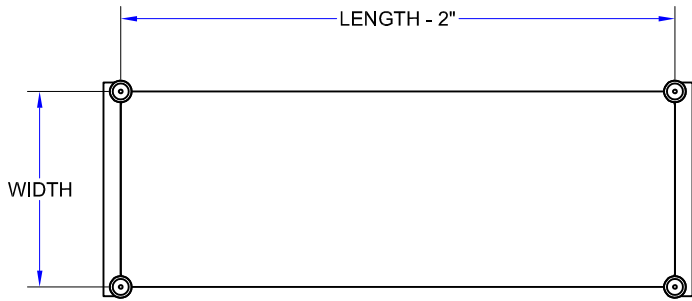

## "OSE26F" OVERSHELVES - ECONOMY SERIES

LENGTH (L)	12" WIDTH	WT (LBS)	18" WIDTH	WT (LBS)
36"	OSE26FK-1236	24	OSE26FK-1836	36
48"	OSE26FK-1248	31	OSE26FK-1848	44
60"	OSE26FK-1260	37	OSE26FK-1860	52
72"	OSE26FK-1272	43	OSE26FK-1872	55
84"	OSE26FK-1284	49	OSE26FK-1884	70
96"	OSE26FK-1296	55	OSE26FK-1896	80
108"	OSE26FK-12108	61	OSE26FK-18108	88
120"	OSE26FK-12120	71	OSE26FK-18120	98
132"	OSE26FK-12132	79	OSE26FK-18132	106
144"	OSE26FK-12144	89	OSE26FK-18144	114

ALL DIMENSIONS ARE TYPICAL. TOLERANCE +/- .500". JOHN BOOS & CO. RESERVES THE RIGHT TO CHANGE SPECIFICATIONS WITHOUT NOTICE.