



Profit from the Eagle Advantage®

Specification Sheet

Short Form Specifications

Eagle Full Size Hot Food Merchandising Cart, model HDC48-120NYF. Heavy gauge stainless steel construction with two insulated heating wells, all-white umbrella, one full-size 12" x 20" pan with hinged lid, one 3/4-size inset with hinged lid, and one 1/2-size inset with hinged lid and two 1 1/4-qt. insets inside. Two 20" ball bearing wheels with rubber tires and one 8" swivel caster. 120-volt 20-amp cord and plug.



Item No.:	_____
Project No.:	_____
S.I.S. No.:	_____

Hot Food Merchandising Cart

MODEL:

HDC48-120NYF

Design and Construction Features

- Stainless steel construction.
- Two insulated heating wells.
- Solid top work surface.
- Complete with cord and 120-volt 20-amp NEMA 5-20 plug.
- 20" (508mm) ball bearing wheels with rubber tires.
- One 8" (203mm) diameter swivel caster.
- One full-size inset with roll top cover.
- One 3/4-size inset with hinged lid.
- One 1/2-size inset with hinged lid with two 1 1/4-quart insets inside.
- All-white umbrella.

Options / Accessories

Custom branding (consult factory)

EAGLE GROUP

100 Industrial Boulevard, Clayton, DE 19938-8903 USA
 Phone: 302-653-3000 • 800-441-8440 • Fax: 302-653-2065
www.eaglegrp.com
www.eaglegrpnews.com
www.eaglemhc.com

For custom configuration or fabrication needs, contact our **SpecFAB® Division**.
 Phone: 302-653-3000 • Fax: 302-653-2065 • e-mail: quotes@eaglegrp.com

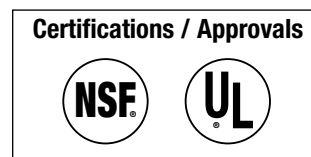

EG35.05 Rev. 04/23

Spec sheets available for viewing, printing or downloading from our online literature library at our websites



Item No.: _____
 Project No.: _____
 S.I.S. No.: _____

Hot Food Merchandising Cart

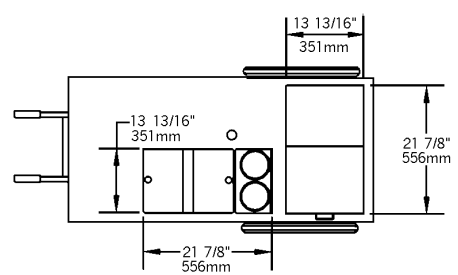

TOP VIEW

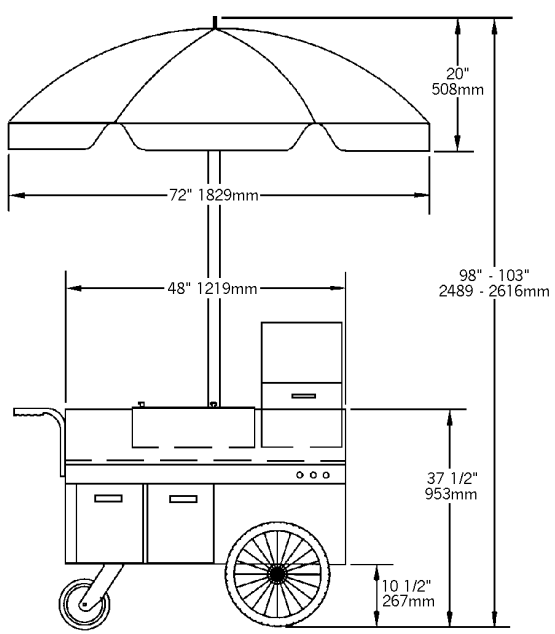

SIDE VIEW

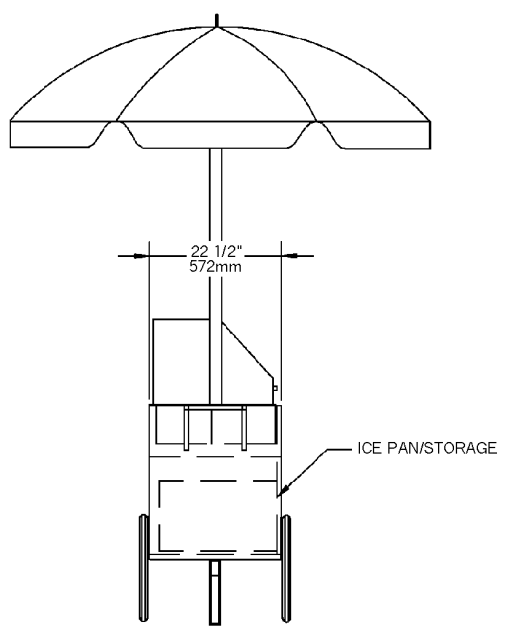

FRONT VIEW

description	width		length		weight		model #
	in.	mm	in.	mm	lbs.	kg	
with hinged lids	22 1/2"	572	48"	1219	431	195.5	HDC48-120NYF

EAGLE GROUP
 100 Industrial Boulevard, Clayton, DE 19938-8903 USA
 Phone: 302-653-3000 or 800-441-8440 • Fax: 302-653-2065
 www.eaglegrp.com • www.eaglegrpnews.com • www.eaglegrp.com

Printed in U.S.A.
 ©2023 by Eagle Group
 Rev. 04/23

Spec sheets available for viewing, printing or downloading from our online literature library at our websites

Although every attempt has been made to ensure the accuracy of the information provided, we cannot be held responsible for typographical or printing errors. Information and specifications are subject to change without notice. Please confirm at time of order.