

**Transfer and Storage Caddys  
for Racks and Trays**

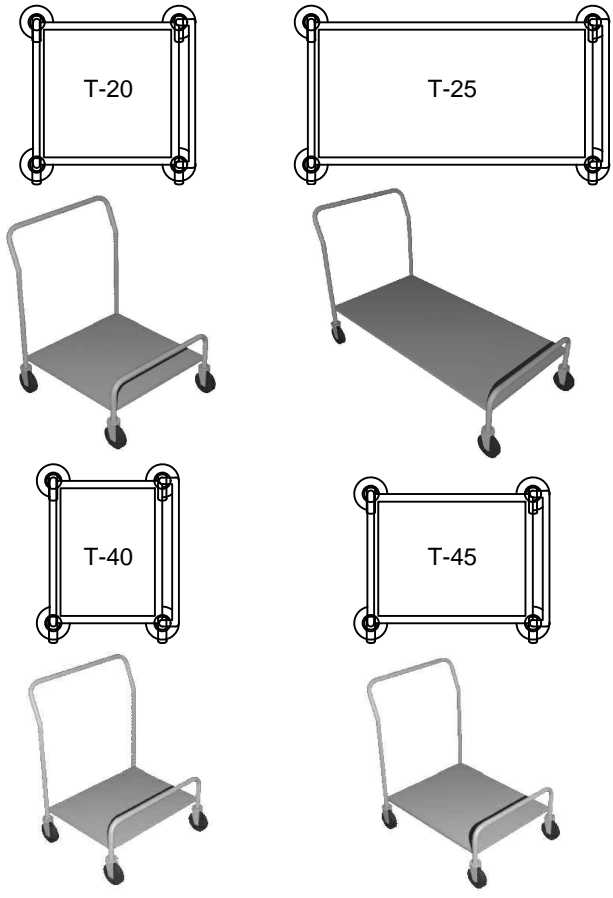

Dimensions				
Model	Length	Width	Height	Rack/Tray
T-20	26 1/2"	26 1/2"	29 1/4"	20" x 20"
T-25	47 1/2"	26 1/2"	29 1/4"	20" x 20" *
T-40	21 1/2"	26 1/2"	29 1/4"	15" x 20"
T-45	29 1/2"	24 1/2"	29 1/4"	16" x 22"

\* Accommodates two stacks

**General Specifications**

Rack and/or Tray Caddy to be Caddy Corporation model T-\_\_\_\_\_.

Frame to be of 1" O.D. 16 gauge stainless steel. Shelf to be 8" (T-25 to be 10") above the floor, of 18 gauge stainless steel with raised rounded edges on all sides, flanged down to form a 1-1/2" wide channel. Shelf corners shaped to fit contour of tubular frame and continuously welded to each leg at all contact points which eliminates unsanitary crevices. Casters to be 4" diameter heavy-duty swivel type with 3/4" stems and polyurethane tires. Tubular frame to be fitted with 4 circular bumpers.

Unit to be provided with the following accessories:

**Accessories**

- ACC-41 - Caster brakes on two diagonal casters.

**T-50 Rack Caddy can accommodate up to five racks of cups glasses or bowls.**

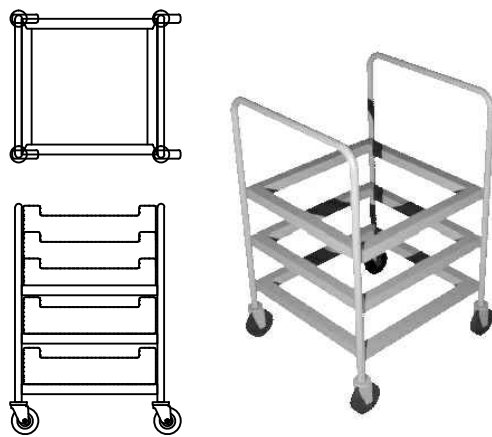

T-50

Dimensions				
Model	Length	Width	Height	Rack
T-50	22 1/2"	21 1/2"	34 3/4"	20" x 20"

**General Specifications**

Rack Caddy to be Caddy Corporation model T-50.

Frame to be of 1" O.D. 16 gauge stainless steel. Rack slides to be 14 gauge 1-1/2" x 1-1/2" stainless steel angles mounted on back and both sides. Rack slides to be continuously welded to each leg at all contact points which eliminates unsanitary crevices. Casters to be 4" diameter heavy-duty swivel type with 3/4" stems and polyurethane tires.

Unit to be provided with the following accessories:

**Accessories**

- ACC-38 - Circular bumpers. (Add 4" to length and width)

**CADDY CORPORATION**  
 509 Sharptown Road P.O. Box 345  
 Bridgeport, NJ 08014-0345  
 Tel: 856-467-4222 Fax: 856-467-5511  
 internet: www.caddycorp.com