



*Warewashing Systems*

**INSTALLATION, OPERATION,  
AND SERVICE MANUAL**



**RACKSTAR®**



**RACKSTAR® SERIES CONVEYOR DISHMACHINES**



# **MANUFACTURER'S WARRANTY**

## **ONE YEAR LIMITED PARTS AND LABOR WARRANTY**

**ALL NEW JACKSON DISHWASHERS ARE WARRANTED TO THE ORIGINAL PURCHASER TO BE FREE FROM DEFECTS IN MATERIAL OR WORKMANSHIP, UNDER NORMAL USE AND OPERATION, FOR A PERIOD OF (1) ONE YEAR FROM DATE OF PURCHASE, BUT IN NO EVENT TO EXCEED (18) EIGHTEEN MONTHS FROM DATE OF SHIPMENT FROM THE FACTORY.**

Jackson WWS agrees under this warranty to repair or replace, at its discretion, any original part which fails under normal use due to faulty material or workmanship during the warranty period, providing the equipment has been unaltered, and has been properly installed, maintained, and operated in accordance with the applicable factory instruction manual and failure is reported to an authorized service agency within the warranty period. This includes the use of factory-specified genuine replacement parts, purchased directly from a Jackson-authorized parts distributor or service agency. Use of generic replacement parts may create a hazard and void warranty certification.

The labor to repair or replace such failed part will be paid by Jackson WWS, within the continental United States, Hawaii, and Canada, during the warranty period provided a Jackson WWS authorized service agency, or those having prior authorization from the factory, performs the service. Any repair work by persons other than a Jackson WWS authorized service agency is the sole responsibility of the customer. Labor coverage is limited to regular hourly rates; overtime premiums and emergency service charges will not be paid by Jackson WWS.

Accessory components not installed by the factory carry a (1) one year parts warranty only. Accessory components such as table limit switches, pre-rinse units, etc. that are shipped with the unit and installed at the site are included. Labor to repair or replace these components is not covered by Jackson WWS.

This warranty is void if failure is a direct result from shipping, handling, fire, water, accident, misuse, acts of God, attempted repair by unauthorized persons, improper installation, if serial number has been removed or altered, or if unit is used for a purpose other than originally intended.

### **TRAVEL LIMITATIONS**

Jackson WWS limits warranty travel time to (2) two hours and mileage to (100) one-hundred miles. Jackson WWS will not pay for travel time and mileage that exceeds this, or any additional fees—such as those for air or boat travel—without prior authorization.

### **WARRANTY REGISTRATION**

To register your product, go to [www.jacksonwws.com](http://www.jacksonwws.com) or call 1-888-800-5672. Failure to register your product will void the warranty.

### **REPLACEMENT PARTS WARRANTY**

Jackson replacement parts are warranted for a period of (90) ninety days from date of installation or (180) one-hundred-eighty days from the date of shipment from the factory, whichever occurs first.

### **PRODUCT CHANGES AND UPDATES**

Jackson WWS reserves the right to make changes in the design and specification of any equipment as engineering or necessity requires.

**THIS IS THE ENTIRE AND ONLY WARRANTY OF JACKSON WWS. JACKSON'S LIABILITY ON ANY CLAIM OF ANY KIND, INCLUDING NEGLIGENCE, WITH RESPECT TO THE GOODS OR SERVICES COVERED HEREUNDER, SHALL IN NO CASE EXCEED THE PRICE OF THE GOODS OR SERVICES OR PART THEREOF WHICH GIVES RISE TO THE CLAIM.**

THERE ARE NO WARRANTIES, EXPRESSED OR IMPLIED, INCLUDING FOR FITNESS OR MERCHANTABILITY, THAT ARE NOT SET FORTH HEREIN, OR THAT EXTEND BEYOND THE DURATION HEREOF. UNDER NO CIRCUMSTANCES WILL JACKSON WWS BE LIABLE FOR ANY LOSS OR DAMAGE, DIRECT OR CONSEQUENTIAL, OR FOR DAMAGES IN THE NATURE OF PENALTIES, ARISING OUT OF THE USE OR INABILITY TO USE ANY OF ITS PRODUCTS.

### **ITEMS NOT COVERED**

THIS WARRANTY DOES NOT COVER CLEANING OR DELIMITING OF THE UNIT OR ANY COMPONENT SUCH AS, BUT NOT LIMITED TO, WASH ARMS, RINSE ARMS, OR STRAINERS AT ANYTIME. NOR DOES IT COVER ADJUSTMENTS SUCH AS, BUT NOT LIMITED TO, TIMER CAMS, THERMOSTATS, OR DOORS BEYOND (30) THIRTY DAYS FROM THE DATE OF INSTALLATION. IN ADDITION, THE WARRANTY WILL ONLY COVER REPLACEMENT WEAR ITEMS SUCH AS CURTAINS, DRAIN BALLS, DOOR GUIDES, OR GASKETS DURING THE FIRST (30) THIRTY DAYS AFTER INSTALLATION. ALSO, NOT COVERED ARE CONDITIONS CAUSED BY THE USE OF INCORRECT (NON-COMMERICAL) GRADE DETERGENTS, INCORRECT WATER TEMPERATURE OR PRESSURE, OR HARD WATER CONDITIONS.

## REVISION HISTORY

Revision Letter	Revision Date	Made by	Applicable ECNs	Details
A	9-21-16	JH	N/A	Initial release of manual.
B	10-25-16	JH	N/A	Corrected delime instructions. Corrected P/Ns for item #6 on pg. 42. Updated pg. 13 to change the pressure regulator from standard to optional. Updated Miscellaneous Electrical Components page. Added a Door Assemblies page. Added a Frame Assembly page. Added Display Fault Codes.



**ELECTRICALLY-HEATED MODELS:**

- RackStar® 44**
- RackStar® 66**

Chemical-sanitizing rack conveyer machine.

**STEAM-HEATED MODELS:**

- RackStar® 44S**
- RackStar® 66S**

Steam-cleaning rack conveyer machine.

Model: \_\_\_\_\_

Serial No.: \_\_\_\_\_

Installation Date: \_\_\_\_\_

Service Rep. Name: \_\_\_\_\_

Phone Number: \_\_\_\_\_

Jackson WWS, Inc. provides technical support for all of the dishmachines detailed in this manual. We strongly recommend that you refer to this manual before making a call to our technical support staff. Please have this manual with you when you call so that our staff can refer you, if necessary, to the proper page. Technical support is not available on holidays.

Contact technical support toll free at 1-888-800-5672.

Technical support is available for service personnel only.

# TABLE OF CONTENTS

## GUIDES

Symbols .....	1
Abbreviations & Acronyms .....	1

## SPECIFICATIONS

Machine Dimensions .....	2
Side-Loader Dimensions .....	6
Steam Booster Heater Dimensions .....	7
Operating Parameters .....	8
Electrical Requirements .....	10

## INSTALLATION

Installation Instructions .....	13
External Device Wiring .....	17
Curtain Installation Instructions .....	18
Drain Quench Kit Instructions .....	19
Operating Instructions .....	21
Display Instructions .....	24
Delime Instructions .....	25

## MAINTENANCE

Preventative Maintenance .....	26
--------------------------------	----

## TROUBLESHOOTING

Common Problems .....	27
Display Programming .....	29
Fault Codes .....	31

## PARTS

Control Box Components .....	33
Miscellaneous Electrical Components .....	34
Wash Heater & Heater Shroud Assemblies .....	35
Pump Suction Assembly .....	36
Wash Heaters .....	37
Plumbing Assemblies .....	38
Pre-Wash Tank Fill Assembly .....	40
Wash Manifold & Arm Assembly .....	41
Pre-Wash Manifold & Arm Assembly .....	43

**PARTS**

Rinse Assembly ..... 45

Pawl Bar Assembly ..... 47

Rack Paddle Assembly ..... 48

Drive Assembly ..... 49

Ventilation Cowl ..... 51

Ventilation Cowl for Unhooded Side-Loader ..... 52

Motor Overloads ..... 53

Side-Loaders ..... 54

Side-Loader Drive Linkage ..... 57

Steam Heating Coil Assembly ..... 58

Booster Heater Option (Electric)..... 59

Frame Assembly ..... 60

Door Assemblies ..... 61

Miscellaneous Parts ..... 62

**SCHEMATICS**

Booster Heater, 3-Phase ..... 63

Booster Heater, 1-Phase, 12 kW ..... 64

Booster Heater, 1-Phase, 18 kW ..... 65

Steam Booster Heater ..... 66

RackStar 208/230 V, 50/60 Hz, 1-Phase ..... 67

RackStar 208/230 V, 50/60 Hz, 3-Phase ..... 68

RackStar 380/480 V, 50/60 Hz, 3-Phase ..... 69

RackStar Side-Loader ..... 70

**ADDENDUM**

Display Template ..... 71

## SYMBOLS



- risk of injury to personnel.



- risk of damage to equipment.



- risk of electrical shock.



- caustic chemicals.



- reference data plate.



- lockout electrical power.

**NOTICE** - important note.

## ABBREVIATIONS & ACRONYMS

**ANSI** - American National Standards Institute

**CFM** - Cubic Feet per Minute

**GHT** - Garden Hose Thread

**GPM** - Gallons per Minute

**GPG** - Grains per Gallon

**HP** - Horse Power

**Hz** - Hertz

**ID** - Inside Diameter

**kW** - Kilowatts

**NFPA** - National Fire Protection Association

**NPT** - National Pipe Thread

**PSI** - Pounds per Square Inch





## 44" RIGHT-TO-LEFT

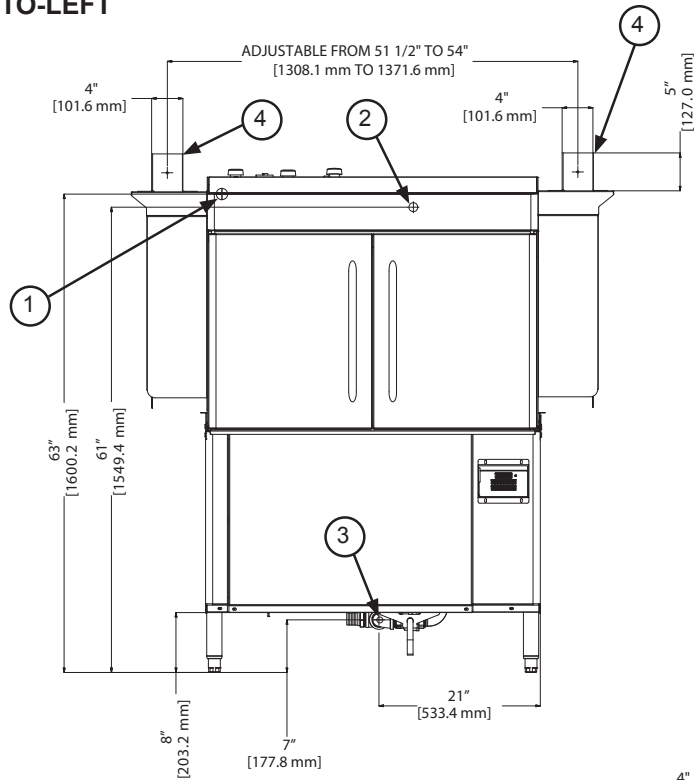

1. Electrical Connection  
*(Provided on both sides of unit)*
2. Water Inlet  
*(1/2" NPT 180 °F)*
3. Drain Connection  
*(1 1/2" NPT)*
4. Vent Connections  
*(Including Dampers)*

*All dimensions from the floor can be increased 1 3/4" using the machine's adjustable feet.*

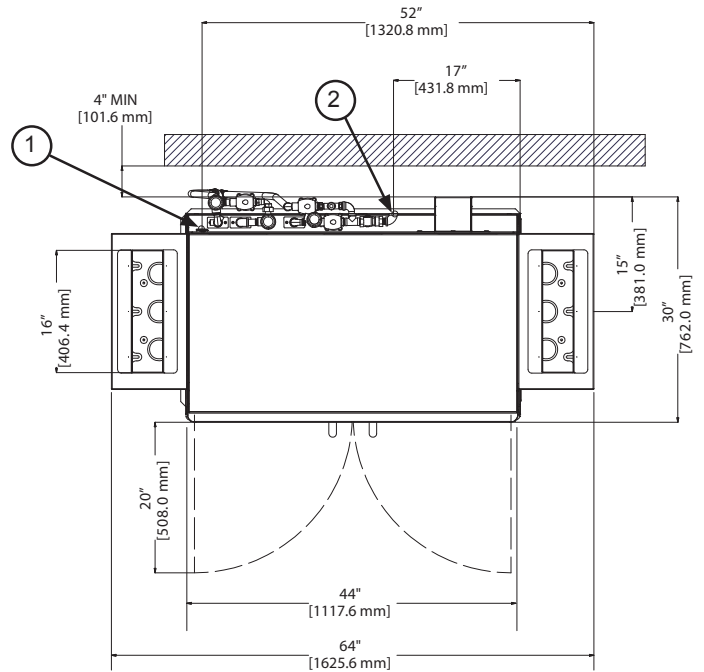
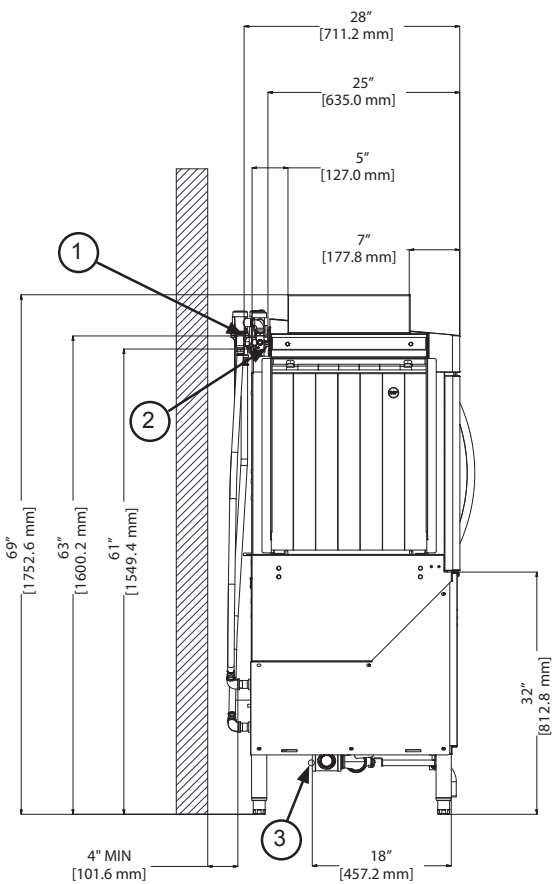



## 66" RIGHT-TO-LEFT

1. Electrical Connection  
*(Provided on both sides of unit)*
2. Pre-Wash Water Inlet  
*(1/2" NPT 180 °F)*
3. Main Water Inlet  
*(1/2" NPT 180 °F)*
4. Vent Connections  
*(Including Dampers)*
5. Drain Connection  
*(1 1/2" NPT)*

All dimensions from the floor can be increased 1 3/4" using the machine's adjustable feet.

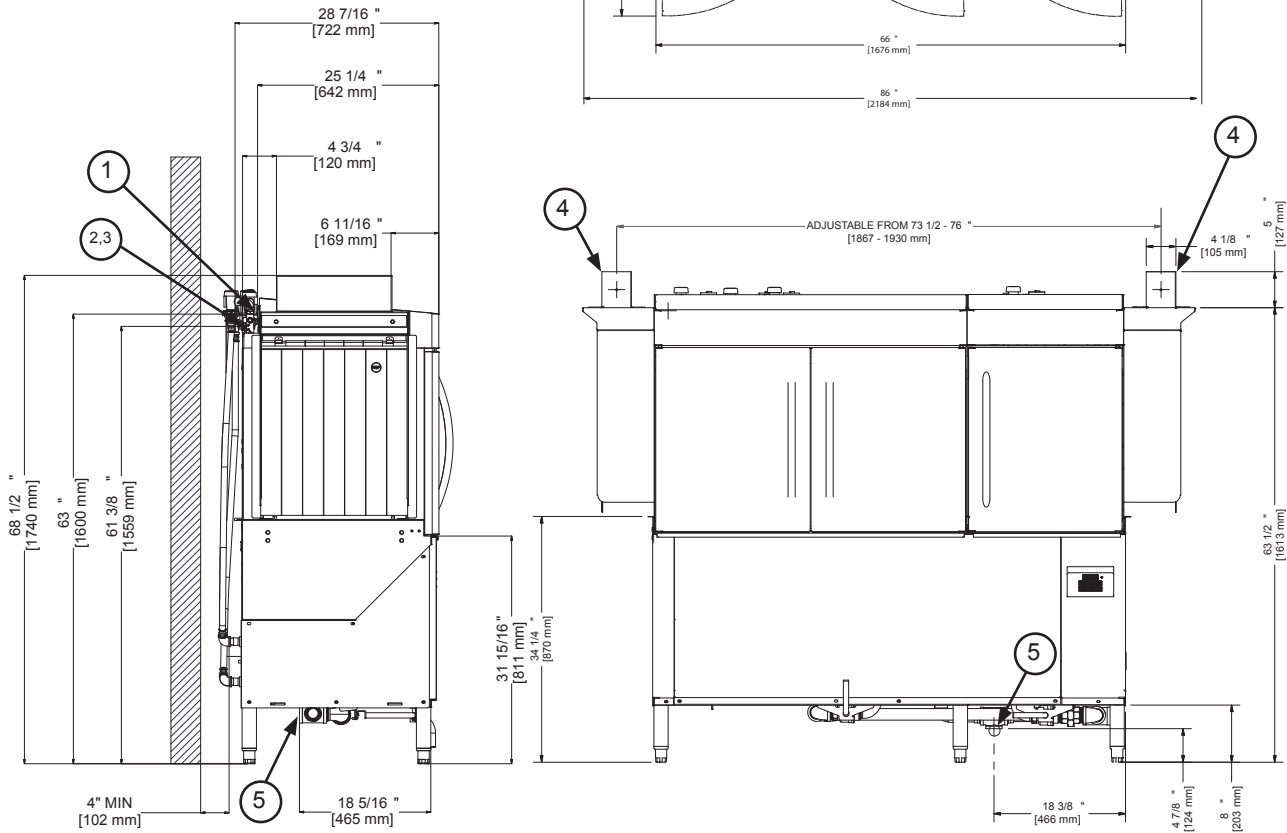
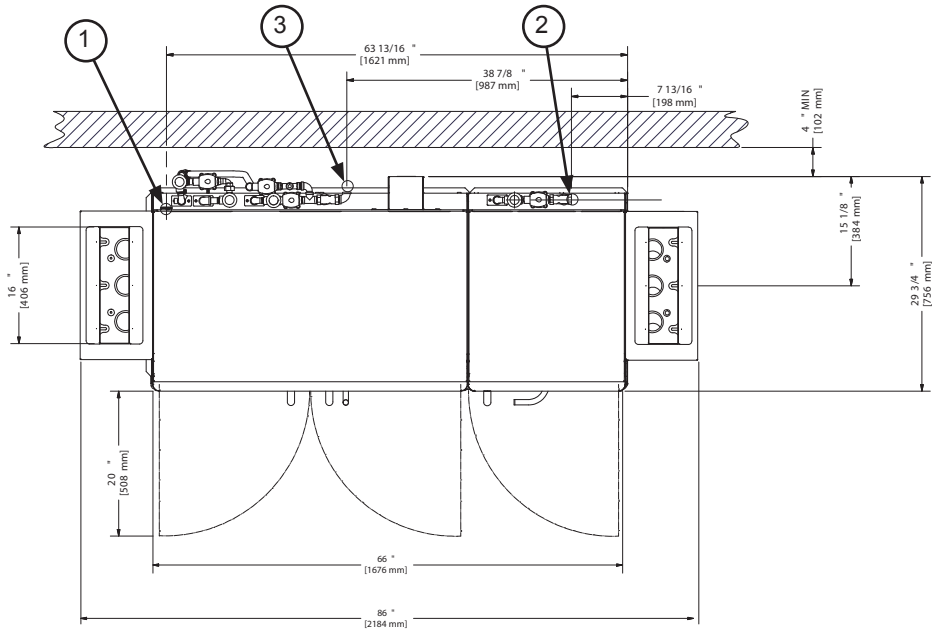

23" L-R UNHOODED  
SIDE-LOADER

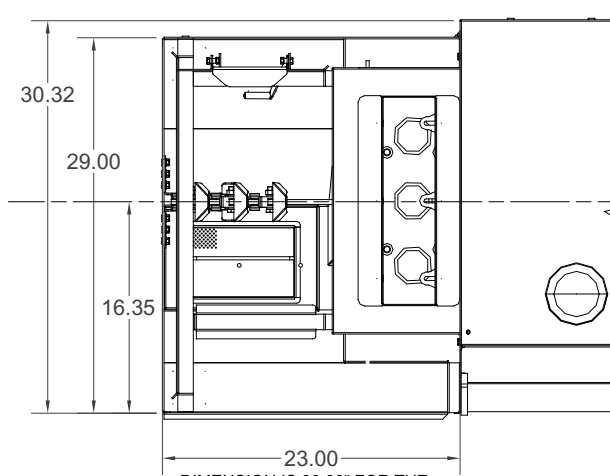

DIMENSION IS 30.00" FOR THE  
30" UNHOODED SIDE-LOADER

23" R-L UNHOODED  
SIDE-LOADER

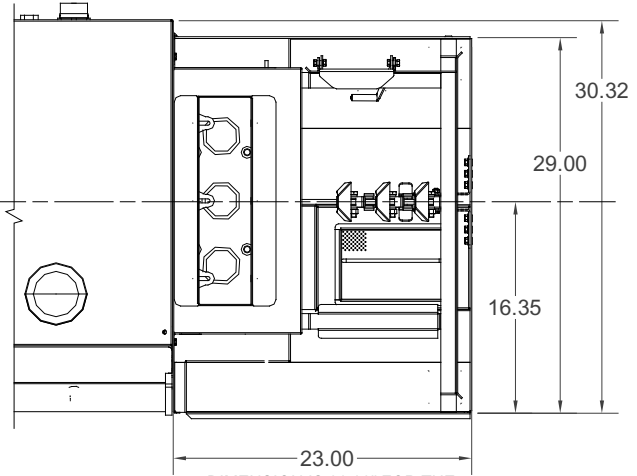

DIMENSION IS 30.00" FOR THE  
30" UNHOODED SIDE-LOADER

ADJUSTABLE VENTILATION  
DUCT ADAPTER

VENTILATION SCOOP

VENTILATION COWL  
WITH CUTOUT FOR  
L-R UNITS

22.00

10.00

ELECTRICAL  
CONDUIT

34.00<sup>+1.00</sup>  
-1.00

SIDE-LOADER  
DRAIN HOSE

ADJUSTABLE VENTILATION  
DUCT ADAPTER

VENTILATION SCOOP

VENTILATION COWL  
WITH CUTOUT FOR  
R-L UNITS

22.00

10.00

ELECTRICAL  
CONDUIT

34.00<sup>+1.00</sup>  
-1.00

SIDE-LOADER  
DRAIN HOSE

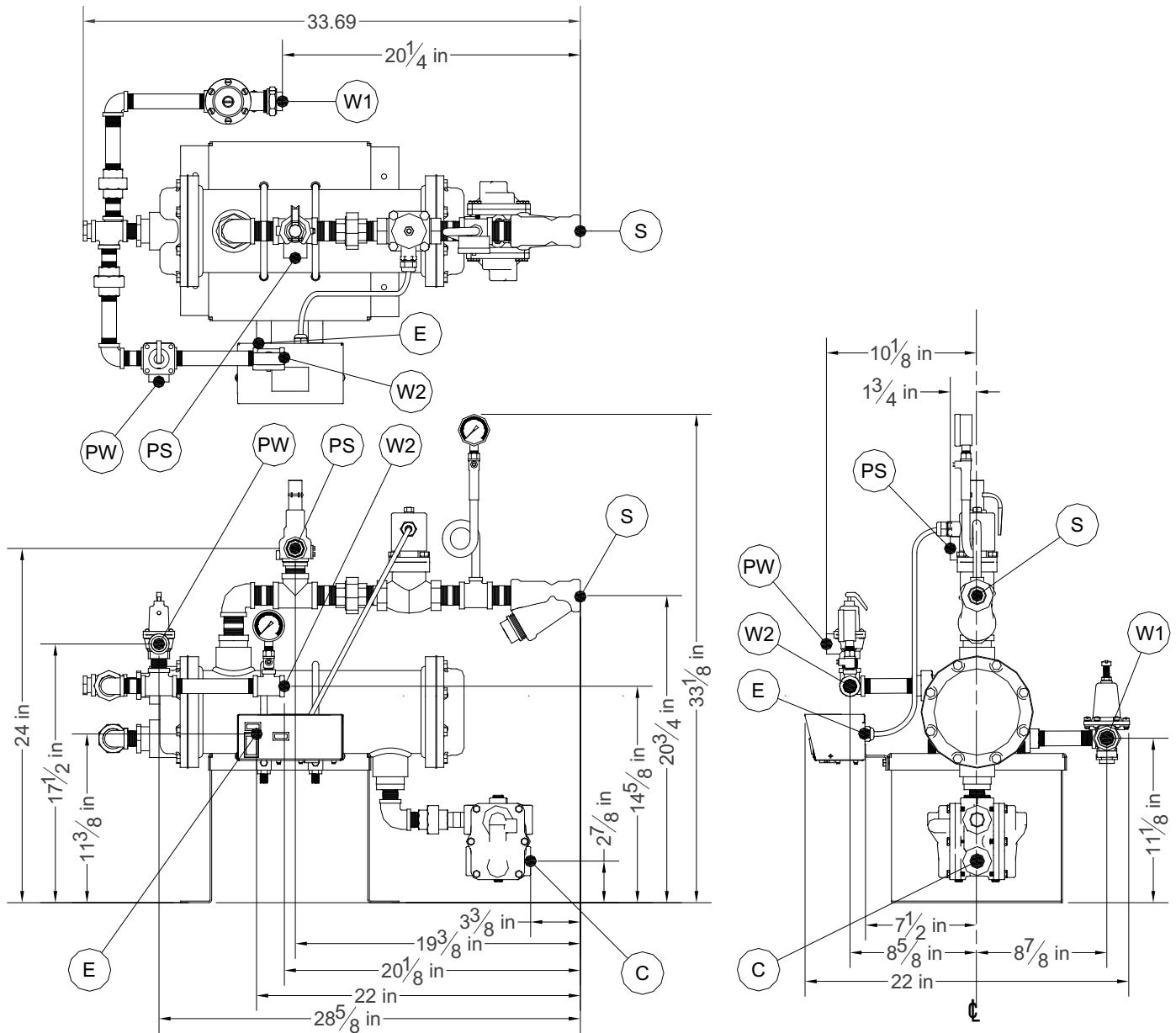

E	MAIN ELECTRICAL CONNECTION (7/8" DIA HOLE)
W1	MAIN INLET WATER CONNECTION (3/4" NPT-F)
W2	WATER OUTLET CONNECTION (3/4" NPT-F)
PW	WATER PRESSURE RELIEF OUTLET (3/4" NPT-F)

PS	STEAM PRESSURE RELIEF OUTLET (1" NPT-F)
S	STEAM SUPPLY TO BOOSTER (1" NPT-F)
C	STEAM CONDENSATE CONNECTION (3/4" NPT-F)

<b>Model Designation:</b>	<b>44"</b>	<b>66"</b>	<b>44" STEAM</b>	<b>66" STEAM</b>
<b>Operating Capacity:</b>				
Racks per Hour	218	218	218	218
Dishes per Hour	3488	3488	3488	3488
Glasses per Hour	7848	7848	7848	7848
<b>Tank Capacity (Gallons):</b>				
Wash Tank	35.6	35.6	35.6	35.6
Pre-Wash Tank	N/A	15.8	N/A	15.8
<b>Electrical Loads (as applicable):</b>				
Wash Motor HP	3.0	3.0	3.0	3.0
Drive Motor HP	0.25	0.25	0.25	0.25
Pre-Wash Motor HP	N/A	2.0	N/A	2.0
Wash Heater kW	15	15	N/A	N/A

**NOTICE**



**NOTE:** Always refer to the machine data plate for specific electrical and water requirements. The material provided on this page is for reference only and may change without notice.

<b>Model Designation:</b>	<b>44"</b>	<b>66"</b>	<b>44" STEAM</b>	<b>66" STEAM</b>
---------------------------	------------	------------	------------------	------------------

**HOT WATER SANITIZING**

**Water Temperatures (°F):**

Pre-Wash Temperature ( <i>recommended</i> )	N/A	110-140	N/A	110-140
Minimum Wash Temperature	160	160	160	160
Incoming Rinse Temperature	180	180	180	180
Incoming Water Temperature				
12 kW Booster	140	140	N/A	N/A
18 kW Booster	110	110	N/A	N/A
No Booster	180	180	180	180

**CHEMICAL SANITIZING**

**Water Temperatures (°F):**

Pre-Wash Temperature ( <i>recommended</i> )	N/A	110-140	N/A	110-140
Minimum Wash Temperature	120	120	120	120
Minimum Rinse Temperature	120	120	120	120
Incoming Water Temperature				
12 kW Booster	80	80	N/A	N/A
18 kW Booster	50	50	N/A	N/A
No Booster	120	120	120	120

**Other Water Requirements:**

Water Flow Pressure (PSI)	15	15	15	15
Flow Rate Minimum (GPM)	1.27	1.18	1.27	1.18
Water Line Size (NPT)	1/2"	1/2"	1/2"	1/2"
Drain Line Size (NPT)	1-1/2"	1-1/2"	1-1/2"	1-1/2"

**Steam Requirements:**

Steam Line for Wash Tank (NPT)	N/A	N/A	3/4"	3/4"
Steam Flow Pressure (PSI)	N/A	N/A	10-20	10-20
Consumption @ 15 PSI (lbs/hr)	N/A	N/A	60	60

**NOTICE**



**NOTE:** Always refer to the machine data plate for specific electrical and water requirements. The material provided on this page is for reference only and may change without notice.





All electrical ratings provided in this manual are for reference only. Always refer to the machine data plate to get the exact electrical information for this machine. **All electrical work performed on machines should be done in accordance with applicable local, state, territorial, and national codes.** Work should only be performed by qualified electricians and authorized service agents. A list of authorized Service Agencies is located in the back of this manual.

Note that all electrical wiring used in the dishmachine must be rated, at a minimum, for 212 °F (100 °C), and that only copper conductors must be used.

Where applicable, heating element amperage draws have been adjusted for the assumed input voltage. The manufacturer assumes incoming voltages will be either 208, 230, or 460 Volts. Some of the heating elements used in our machines are actually rated for other voltages, such as 240 or 480 Volts. Always verify the amperage draw of the machine in operation when sizing circuit protection.

If the machine is equipped with the optional rinse heater, note the rinse heater has its own electrical connection and therefore requires a separate service. Amperage loads for motors and heaters are called out on the machine data plate for the installation/service technician.

The electrical configurations of the machines are as follows:

**Available Electrical Characteristics:**

- 208 V, 60 Hz, Single-phase
- 230 V, 60 Hz, Single-phase
- 208 V, 60 Hz, Three-phase
- 230 V, 60 Hz, Three-phase
- 460 V, 60 Hz, Three-phase

**Available Wash Tank Heaters:**

- 15 kW

**Available Booster Tank Heaters:**

- None (standard)
- 12 kW (40 °F rise in temperature)
- 18 kW (70 °F rise in temperature)



**44"**

Volts	Phase	Hz	Wash Motor Amps	Drive Motor Amps	Wash Heater Amps	Total Load
208	1	60	10.0	1.8	72.1	83.9
230	1	60	10.0	1.8	59.9	71.7
208	3	60	8.6	1.1	41.6	51.3
230	3	60	8.4	1.1	34.6	44.1
460	3	60	4.2	0.6	17.3	22.1

**44" Steam**

Volts	Phase	Hz	Wash Motor Amps	Drive Motor Amps	Total Load
208	1	60	10.0	1.8	11.8
230	1	60	10.0	1.8	11.8
208	3	60	8.6	1.1	9.7
230	3	60	8.4	1.1	9.5
460	3	60	4.2	0.6	4.8



## 66"

Volts	Phase	Hz	Pre-Wash Motor Amps	Wash Motor Amps	Drive Motor Amps	Wash Heater Amps	Total Load
208	1	60	10.2	10.0	1.8	72.1	94.1
230	1	60	9.4	10.0	1.8	59.9	81.1
208	3	60	6.2	8.6	1.1	41.7	58.3
230	3	60	6.4	8.4	1.1	34.6	50.5
460	3	60	3.2	4.2	0.6	17.3	25.3

## 66" Steam

Volts	Phase	Hz	Pre-Wash Motor Amps	Wash Motor Amps	Drive Motor Amps	Total Load
208	1	60	10.2	10.0	1.8	22.0
230	1	60	9.4	10.0	1.8	21.2
208	3	60	6.2	8.6	1.1	15.9
230	3	60	9.4	10.0	1.1	20.5
460	3	60	3.2	4.2	0.6	8.0

## 40 °F Rise – 12 kW Booster

Volts	Phase	Hz	Rinse Heater Amps
208	1	60	57.7
230	1	60	47.9
208	3	60	33.3
230	3	60	27.7
460	3	60	13.8

## 70 °F Rise – 18 kW Booster

Volts	Phase	Hz	Rinse Heater Amps
208	1	60	82.7
230	1	60	71.9
208	3	60	47.7
230	3	60	41.5
460	3	60	20.7

Note: On the 208 V machines, the rinse heater is actually rated at 17.2 kW.

## Blower/Dryer

Volts	Phase	Hz	Amps
208	3	60	32.2
230	3	60	22.9
460	3	60	13.4

## VISUAL INSPECTION

*Do not throw away the container if damage is evident!*

Before installing the unit, check the packaging and the machine for damage. Damaged packaging might be an indication there is possible damage to the product. If there is any type of damage to both the packaging and the unit, **DO NOT THROW AWAY THE PACKAGING**. The dishmachine has been previously inspected at the factory and is expected to arrive in new, undamaged condition. However, rough handling by carriers or others might result in damage to the unit while it is in transit. If this occurs, **DO NOT RETURN THE UNIT TO THE MANUFACTURER**. Instead, contact the carrier and ask them to send a representative to the site to inspect the damage and request that an inspection report be completed. Contact the carrier and dealer that sold you the unit within 48 hours of receiving the machine in order to report possible freight damage.

## UNPACKING THE MACHINE

The machine should be unboxed and removed from the pallet before installing. Remove the wooden lift beams and their associated brackets after the unit has been positioned. Open the front door and remove all materials from inside. Once unpacked, verify there are no missing parts. If a part is missing, contact the manufacturer immediately.

## LEVEL THE DISHMACHINE

The dishmachine is designed to operate while level. This is important to prevent any damage to the machine during operation and to ensure the best possible results. The unit comes equipped with adjustable bullet feet, which can be turned using a pair of pliers. Verify the unit is level from front-to-back and side-to-side before making any electrical or plumbing connections.

## PLUMBING THE DISHMACHINE

*The plumber **MUST** flush the incoming water line!*

All plumbing connections must be made to adhere to local, state, territorial, and national codes. The installing plumber is responsible for ensuring the incoming water lines are flushed of debris before connecting to the machine. Note that chips and materials from cutting processes can become lodged in the solenoid valves and prevent them from opening or closing. Any valves that are found to be fouled or defective because of foreign matter left in the water line and any subsequent water damage are not the responsibility of the manufacturer.

Water hardness should be a maximum of 6 GPG. Hard water should be treated before being used by the machine. Iron in the water line can cause staining. A filter designed to remove iron from the water supply is highly recommended for supplies in excess of 0.1 ppm.

The manufacturer has an optional water pressure regulator to accommodate areas where water pressure fluctuates or is higher than the recommended pressure. The unit utilizes a flow pressure of 15 PSI for the incoming water line. Do not confuse static pressure with flow pressure. Static pressure occurs when there is no flow and the valves are closed. Flow pressure occurs when water is running into the machine. The pressure regulator should be adjusted to the proper flow pressure indicated on the data plate.

The water supply line must be 1/2" NPT minimum and must be able to provide water at the minimum temperature indicated on the machine data plate.

A shut-off valve should be installed to allow isolating the dishmachine from the water system in the event service is required. It is also suggested that a shock absorber (**not supplied** with dishmachine) be installed on the incoming water line. This prevents water hammer (hydraulic shock)—induced by the solenoid valve as it operates—from causing damage to the equipment.



## CONNECTING THE DRAIN LINE

The drain for the unit is a gravity discharge drain. All piping to the machine drain must be a minimum 1-1/2" NPT AND MUST NOT BE REDUCED. There must also be an air gap between the machine drain line and the floor sink or drain. If a grease trap is required by code, it should have a flow capacity of 5 GPM. 44" units have one drain connection point and 66" units have two.

## STEAM LINE CONNECTIONS



Some machines covered in this manual are designed to use low-pressure steam as a source of heat for the wash tank. Those machines come with lines by which an outside source of steam (e.g. steam booster) is connected. Connect all steam lines from the booster to the machine in accordance with the booster manufacturer's instructions. Ensure that all applicable codes and regulations are adhered to. See the machine data plate for information related to steam flow requirements.

## ELECTRICAL POWER CONNECTIONS



*Disconnect electrical power at the breaker or disconnect switch and tag-out in accordance with procedures and codes.*

All electrical connections are to be made in accordance with applicable portions of local, state, territorial, and national codes.

This manual provides reference information regarding electrical requirements and loads, but that information may change without notice. Always refer to the machine data plate for voltage requirements, machine voltage, total amperage load, and serial number. If a data plate has been damaged and cannot be read, contact the manufacturer.

The main power terminal blocks (for the dishmachine and for the rinse booster heater, if applicable) are located at the top of the machine. Remove the top cover to access these connections. Route incoming power lines within conduit that will connect via fittings to the pre-punched holes in the back of the control box. Install power and ground wires to lugs as indicated by the appropriate decals in the control box. Use copper conductors only. Use of an anti-oxidation agent is permissible on the power connections. Tighten all connections.

Verify the incoming voltage matches the voltage indicated on the decal next to the incoming power pre-punched hole.

### NOTICE

**NOTE:** The dishmachine has a separate power connection from the rinse booster heater and the circuit protection requirements are different for each. Refer to the machine data plate for information on minimum circuit protection.



**CAUTION:** Improperly connecting external devices can cause damage to the machine and/or electrical infrastructure!

**SEE PAGE 17 FOR A GUIDE ON WIRING EXTERNAL DEVICES (EXHAUST FAN, CHEMICAL DISPENSERS, ETC.)**

## DISHMACHINE VENTILATION

The dishmachine should be located with an adequate exhaust hood or ventilation system with provisions for venting. This is essential to permit efficient removal of the condensation exhaust. Ensure the exhaust system is acceptable in accordance with applicable codes and standards.

**NOTICE** NOTE: Any damage that is caused by steam and/or moisture due to improper ventilation is NOT covered under the warranty.

Dishmachine ventilation requirements:

- **Load End: 200 CFM**
- **Unload End: 200 CFM**

The exhaust system must be sized to handle this volume for the dishmachine to operate properly.

---

## THERMOSTATS

The thermostats on this unit have been set at the factory for the wash tank and should only be adjusted by an authorized service agent.

---

## CHEMICAL FEEDER EQUIPMENT



This dishmachine DOES NOT COME WITH AN INTEGRAL CHEMICAL SUPPLY/FEEDER SYSTEM. For the dishmachine to operate correctly, connect it to a third-party chemical dispenser that meets the requirements of NSF Standard 29.

Contact a chemical supplier about connecting a dispenser to the dishmachine. Chemical dispensers must be set for the type and concentration of chemicals being used.

Detergent usage and water hardness are two factors that contribute greatly to how efficiently the dishmachine will operate. Using the proper amount of detergent can be a source of substantial savings. A qualified water treatment specialist can explain what is needed to gain the maximum efficiency from detergent.

The dishmachine can operate in either hot-water-sanitizing mode or chemical-sanitizing mode. The mode of the machine is marked above the machine's data plate.

If the unit is operated in chemical-sanitizing mode, ensure an appropriate chlorine-based sanitizer is used in the final rinse line.

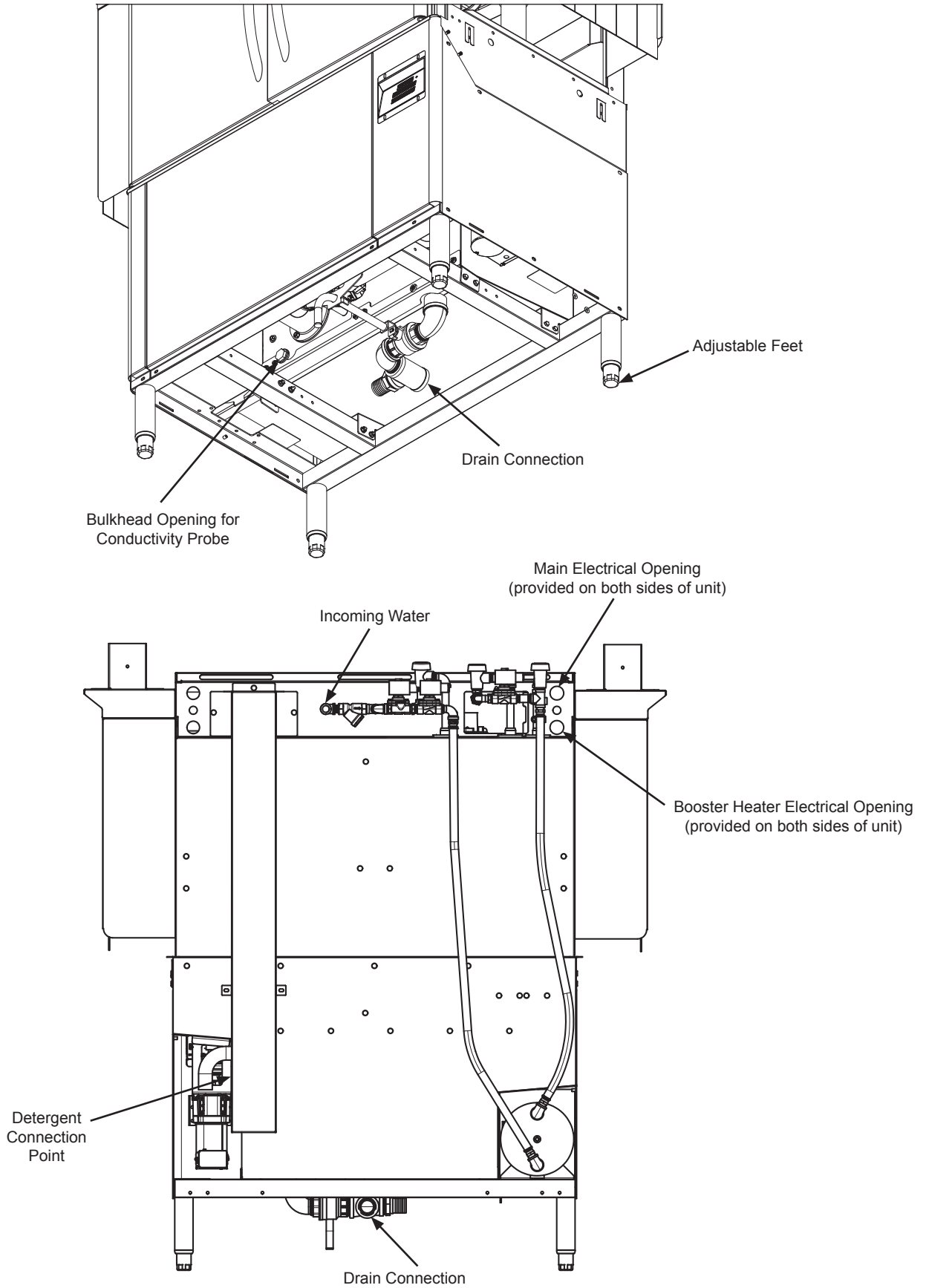

## Wiring Diagram



Do NOT connect primary load directly to Terminal Board!

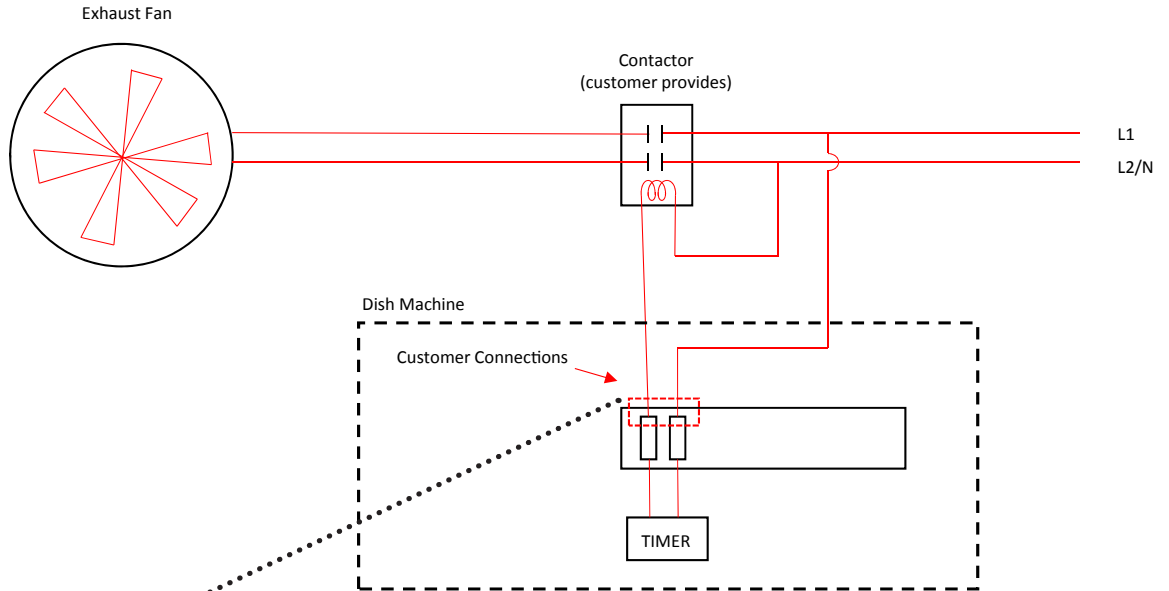

## Terminal Board

**WARNING: DISCONNECT POWER TO MACHINE BEFORE SERVICING**

EXHAUST FAN CONNECTION		CONSTANT VOLTAGE CONNECTION		RINSE AID DISPENSER CONNECTION		DETERGENT DISPENSER CONNECTION	
MAXIMUM LOAD 1 AMP, 240/120 VAC		LIVE WHEN MACHINE POWER SWITCH IS ON		LIVE WHEN RINSE VALVE IS OPEN		LIVE WHEN WASH PUMP MOTOR IS ON	
INPUT L1 (EXTERNAL)	OUTPUT TO EXT. RELAY	FUSE: 3 AMP SLOW-ACTING L1 OUT	L2 OUT	FUSE: 3 AMP SLOW-ACTING L1 OUT	L2 OUT	FUSE: 3 AMP SLOW-ACTING L1 OUT	L2 OUT

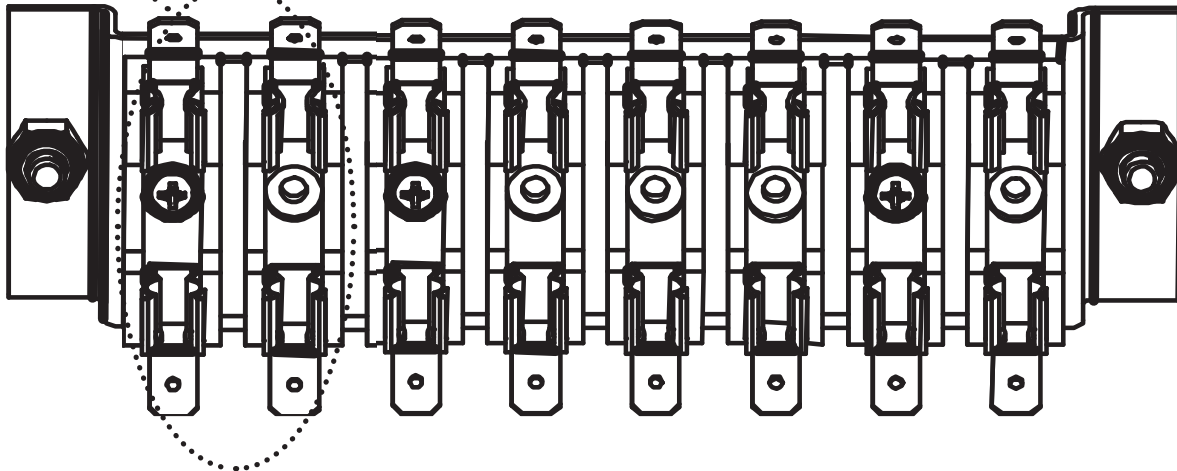

## Chemical Supplies

**Chemical Dispenser Tube Connection**  
Points to Rinse Injector:

- P: Pressure Switch (1/4" NPT)
- S: Sanitizer (1/8" NPT)
- R: Rinse Aid (1/8" NPT)

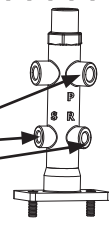



The unit has decals marking the curtain locations inside the machine, starting at the load end and ending at the unload end. The illustrations below indicate the size of the curtain to be placed on the curtain hooks provided. If any curtain components are missing, these must be obtained and installed before operation.

**DETERMINING CONVEYER DIRECTION:** The dishmachine will be configured for either Left-to-Right or Right-to-Left operation. Direction is from the load end to the unload end, as shown below.

### 44" Left-to-Right

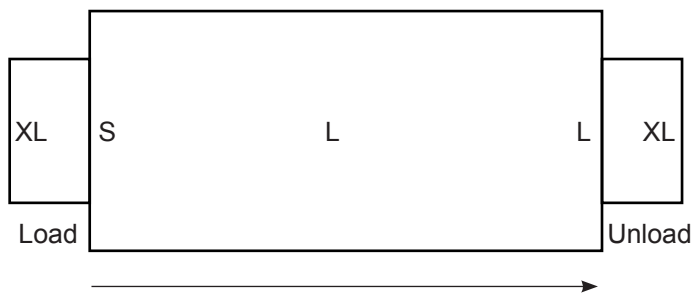

### 44" Right-to-Left

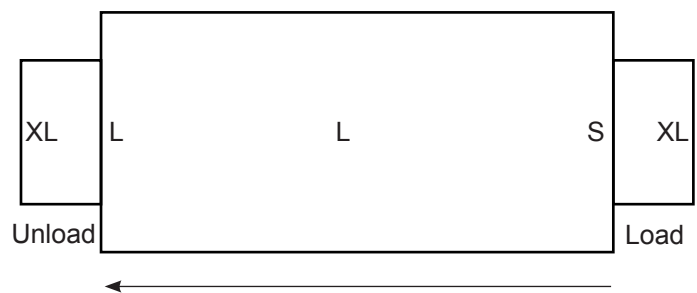

### 66" Left-to-Right

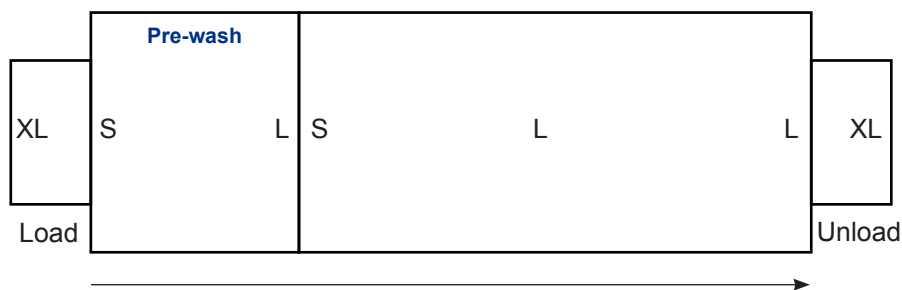

### 66" Right-to-Left

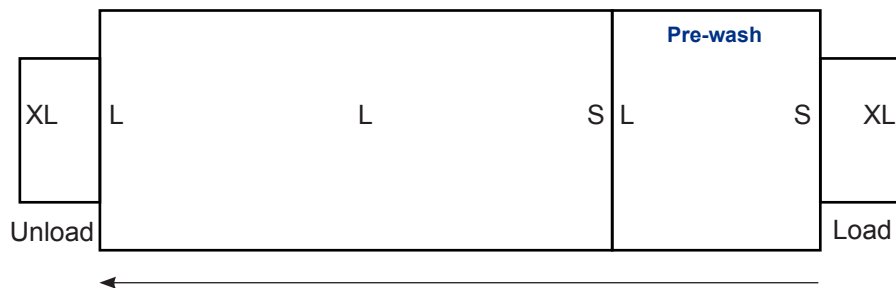

**IMPORTANCE OF PROPER CURTAIN PLACEMENT:** The curtains inside the dishmachine must be installed properly for the machine to operate correctly. Curtains are used to control air currents inside the unit and assist in maintaining the heat necessary to keep energy costs down. Note the approximate locations for each type of curtain in the above illustrations.

**S = Short, L = Long, and XL = Extra Long.** See the chart below for actual curtain lengths and part numbers. Note the different part numbers for the curtain and curtain rod for the load end when a side-loader option is present.

Legend	Length	Part #	Side-Loader Option	Part #
S	12"	08415-131-73-44	XL (Load End Only)	08415-003-84-88
L	19"	08415-002-14-41	Curtain Rod (Load End Only)	05700-003-84-57
XL	24.25"	08415-002-47-37		
Curtain Rod	20.50"	05700-003-77-52		



- This kit should only be installed by qualified service personnel to reduce the risk of electric shock, serious injury, or fire. A plumbing permit and the services of a licensed plumber and electrician might be required in some areas.
- Turn off the power supply and place the dishwasher disconnect (if applicable) in the off position. Lockout/tag-out to prevent the power supply from being turned back on accidentally.
- Failure to install this kit within the guidelines might adversely affect safety, performance, component life, and warranty coverage.
- Do NOT pull power for the Drain Quench Assembly from the machine! 120V facility power only!

### **Tools Required**

- Pipe Wrench
- Adjustable Wrench
- 5/16" Nut Driver
- 3/8" Nut Driver or Wrench
- Phillips Screwdriver
- Pipe Thread Sealant Tape or "Pipe Dope"
- Needle-nose Pliers

### **Instructions**

1. Connect Drain Quench Assembly to the machine drain via 1.5" NPT street elbow (04730-206-32-00).
2. Orient assembly as shown below:



3. Connect user-supplied 115V cord (from facility power) into solenoid box as shown below:



Power cannot be taken from the machine!

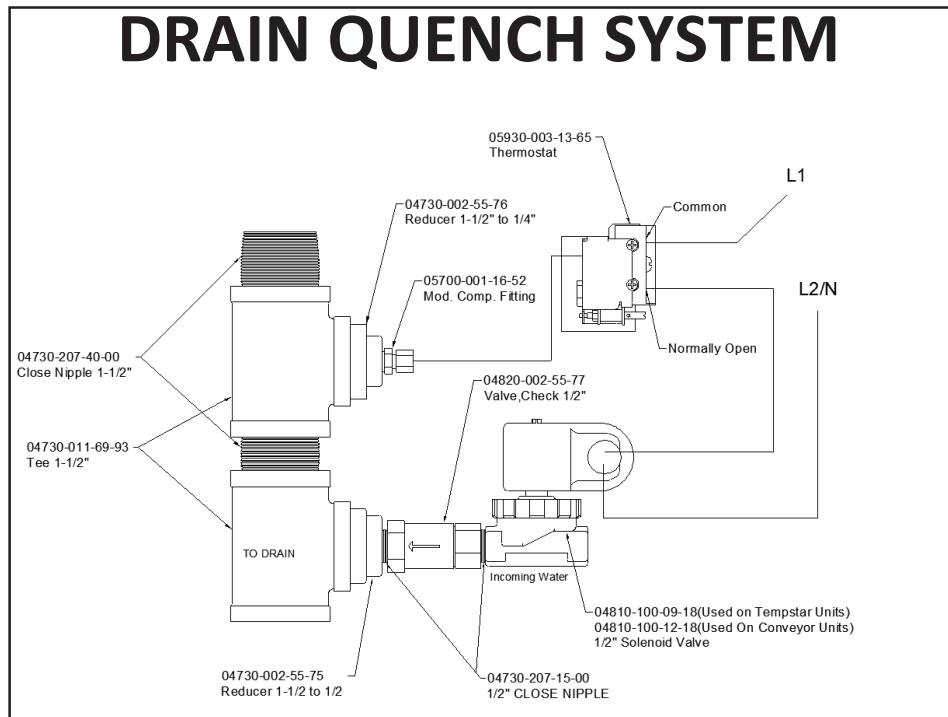

4. Connect cold water to inlet side of solenoid valve.
5. Secure all electrical (ensure connection is to 120V facility power) and plumbing connections.
6. Restore water and power to the machine and verify drain quench performance.

**IF THERE ARE ANY ISSUES AFTER INSTALLATION, PLEASE CONTACT  
TECHNICAL SERVICE AT 1-888-800-5672.**

**PREPARATION** Before operating the unit, verify the following:

- The strainers are installed.

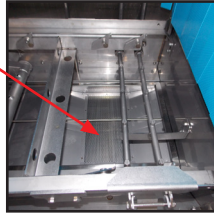

- The drain valve is closed.



- The actuator switches move with relative freedom and do not bind.

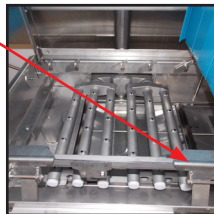

- The curtains are installed correctly.

**POWER UP** To place the unit in standby, press the START button on the display.

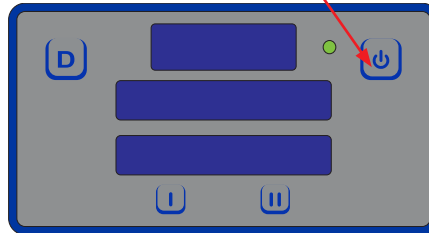

- The unit will automatically determine if there is proper water level in the wash tank. If not, the unit will begin to fill until the appropriate level is reached.
- If the wash tank temperature is not at the minimum level for the mode of operation, the wash heater will energize. Refer to the machine data plate for a better understanding of the minimum temperatures needed to operate the unit correctly. It might take several minutes for the wash tank to heat up, depending on the initial temperature of the water.
- If the machine is equipped with a rinse booster option, the booster will turn on when the unit turns on.
- If the machine is heated with a steam booster, the steam booster must be turned on in accordance with the manufacturer's instructions.
- Do not attempt to start the unit until:
  1. The unit stops filling.
  2. The unit has reached the appropriate wash tank temperature.

**FIRST RACK** The first rack of ware that is placed in the unit will typically reduce the temperature of the wash tank, and the first rack might need to run through the unit again. This process might be necessary any time the unit has not been operated for an extended period of time, although this is dependent on the type of ware being used, its temperature, and the ambient temperature of the kitchen area. To ensure proper operation, always observe the temperatures of the wash and rinse when first starting the unit.

**WARE PREPARATION** Proper preparation of ware is essential for the smooth, efficient operation of this dishmachine.

Any ware placed in the unit should have all solid food waste and scraps removed. Ware should also be sprayed-down before entering the dishmachine.

Place cups and glasses upside-down in racks so they do not hold water during the cycle. Presoak flatware in warm water to assist in removing food. Load plates and saucers in the same direction, with the food surface facing the unload end of the machine.

**WASHING A RACK OF WARE** This dishmachine is designed to wash ware that is placed in a rack. Materials should not be placed in the unit unless they are properly secured in a dish rack.

To start the cycle, gently push the rack into the unit on the load end. Once the wash actuator has moved sufficiently, the unit will automatically begin to convey the dish rack through the unit. The entire cycle is automatic.



**OPERATIONAL INSPECTION** Operators should periodically review the following items while the machine is operating. These items are important for operating the machine in an efficient manner.



- Review wash and rinse temperatures and compare to the minimums on the data plate.
- Verify the pan strainers are not becoming clogged. Keeping these free of soil and debris allows for much better flow of water through the machine and prevents any sort of redeposit issues.
- Water pressure: The dishmachine is designed to run at a minimum of 15 PSI; if it is any lower there will not be enough rinse water to properly remove detergent from the ware.
- Wash and rinse arm nozzles should be free of debris. Open nozzles are essential to the operation of the dishmachine.

**SHUTDOWN** To shut the unit down, press the START button on the front of the machine. To drain the machine, move the drain valve to the drain position. If the machine is equipped with a steam booster, shut it down in accordance with its manufacturer's instructions.

**CLEANING** Clean the unit at least once every 24 hours or at the end of the day. Cleaning assists in maintaining the efficient operation of the unit by removing soil and debris that might otherwise become trapped in nozzles or deposited onto ware.

*Do NOT clean the unit with any type of metallic scrubbing sponge!*

- Curtains should be removed and scrubbed with mild detergent and a brush and allowed to air-dry.



- Strainers should be removed and debris scooped out. Do not hit strainers to remove debris; this can cause them to warp and not seat correctly. Rinsing the strainer under water should remove the rest of any debris trapped in the part.

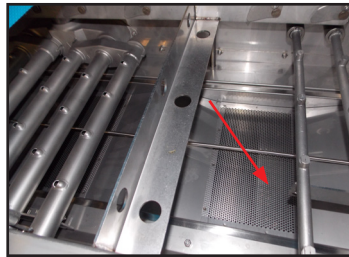

- Wash arms can be removed using a 7/16" driver. However, the dishwasher is designed so that the wash arms are self-cleaning. Operators have the ability to flush the arms by removing the plastic end-caps and running a rack through the unit. This should only be done as a cleaning function with an empty rack and a tub that is filled with water.

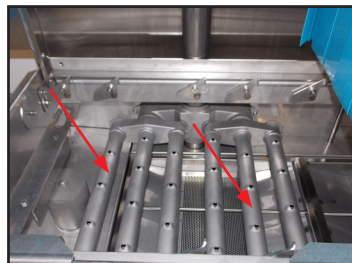

- The internal chamber can be cleaned with a mild detergent and dishrag. The strainers and pawl bar should be removed to provide as much room as possible.
- The outside of the unit should be cleaned with a standard countertop or general cleaner. Do not attempt to clean inside any compartments, boxes, or chambers that are secured with a cover. These normally contain live electrical components.

**RINSE MODES** Press the I Key for ECONO RINSE.  
Press the II Key for TURBO RINSE.

**CHECKING CYCLE COUNT** While the unit is powered off, press and hold the Power Key. The total cycle count will display for several seconds, followed by a normal .ON state.

- GENERAL**
1. When main power is first connected to the unit, the digital display will sequence through its LEDs to show all are functional.
  2. The unit will then go into Standby Mode (blank display).
  3. Press the Power Key.
  4. The display will show "Heating" until the wash tank reaches operating temperature.

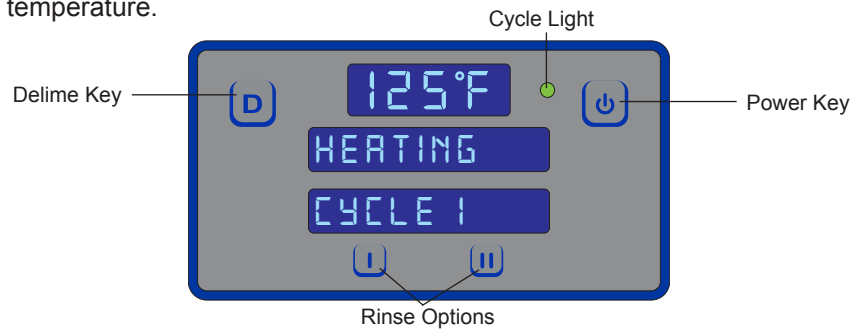

5. The display will show "Ready" when the unit is ready to use.

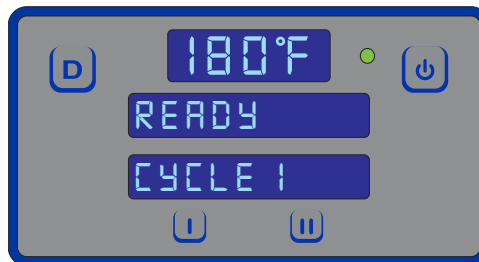

## OPERATIONAL MESSAGES

DISPLAY	CONDITION
"Check doors"	One of the doors is not fully closed or one of the switches is not being triggered.
"Filling"	The wash tank is filling with water.
"Heating"	The unit is heating the water in the wash tank.
"Delime"	The Delime Key has been pressed.
"Ready"	The dishmachine is ready for operation.
"Wash Temp"	A rack of dishes is progressing through the wash section.
Alternates "Wash Temp" & "Rinse Temp"	A rack of dishes is progressing through the rinse section.

**DELIME  
INSTRUCTIONS**

To proceed with the delime operation, fill the dishmachine with the correct amount of delime solution as recommended by the chemical supplier. The tank capacities of the machine can be found in the Specifications section of this manual.

After the chemicals are added, perform the following steps:

1. Press the DELIME button.

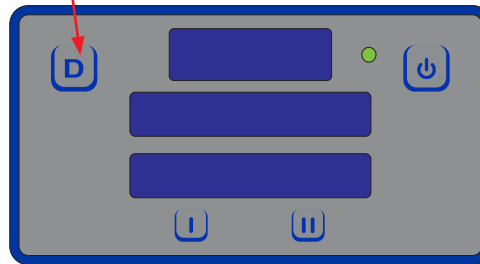

2. Disconnect or turn off chemical feeder pumps.
3. Close the doors.
4. Press the START button and run the machine for the length of time recommended by the chemical supplier.
5. Press the START button to shut the unit off.
6. Wait five minutes, then inspect the inside of the machine. If the machine is not delimed, run again.
7. Once clean, drain and re-fill the machine and run two cycles to remove residual deliming solution.
8. Drain and re-fill the machine.
9. The machine is ready to use.

**This equipment is not recommended for use with deionized water or other aggressive fluids. Use of deionized water or other aggressive fluids will result in corrosion and failure of materials and components. Use of deionized water or other aggressive fluids will void the manufacturer's warranty.**



**PREVENTATIVE MAINTENANCE** Jackson highly recommends that any maintenance and repairs not specifically discussed in this manual be performed only by QUALIFIED SERVICE PERSONNEL. Performing maintenance on your dishmachine may void your warranty, lead to larger problems, or even cause harm to the operator. So if you have a question or concern, do not hesitate to contact a QUALIFIED SERVICE AGENCY.

By following the operating and cleaning instructions in this manual, you should get the most efficient results from your machine. As a reminder, here are some steps to take to ensure that you are using the dishmachine the way it was designed to work:



1. Ensure that the water temperatures match those listed on the machine data plate. There can be a variety of reasons why your water temperature could be too low.
2. Ensure that all strainers are clean and in place laying flat before operating the machine. When cleaning out strainers, do NOT beat them on waste cans. Wipe out strainers with a rag and rinse under a faucet if necessary. Use a toothpick to dislodge any stubborn debris.
3. Ensure that all wash and/or rinse arms are secure in the machine before operating.
4. Ensure that drains are closed/sealed before operating.
5. Remove as much soil from dishes by hand as possible before loading into racks.
6. Do not overfill racks.
7. Ensure that glasses are placed upside-down in the rack.
8. Ensure that all chemicals being injected into machine have been verified as being at the correct concentrations.
9. Clean the unit every 24 hours or at the end of every workday per the instructions in this manual.
10. Follow all safety procedures, whether listed in this manual or put forth by local, state, or national codes/regulations.



**WARNING:** Inspection, testing, and repair of electrical equipment should only be performed by a qualified service technician. Many of the tests require that the unit have power to it and live electrical components be exposed. **USE EXTREME CAUTION WHEN TESTING THE MACHINE.**

PROBLEM	POSSIBLE CAUSE	REMEDY
Dishmachine will not fill after the door is closed. Power "ON" light is illuminated.	<ol style="list-style-type: none"> <li>1. Faulty rinse solenoid valve.</li> <li>2. Faulty door switch.</li> </ol>	<ol style="list-style-type: none"> <li>1. Repair or replace valve as required.</li> <li>2. Verify the wiring of the switch; if correct, replace switch.</li> </ol>
Dishmachine will not fill after the door is closed. Power "ON" light is NOT illuminated.	<ol style="list-style-type: none"> <li>1. Service breaker tripped.</li> <li>2. Machine not connected to power source.</li> <li>3. Faulty power source.</li> </ol>	<ol style="list-style-type: none"> <li>1. Reset; if the breaker trips again, contact an electrician to verify the amp draw of the machine.</li> <li>2. Verify that the machine has been properly connected to the power source.</li> <li>3. Verify working power source.</li> </ol>
Dishmachine will not run after the door is closed. Power "ON" light is illuminated and the unit is filling.	<ol style="list-style-type: none"> <li>1. Wash motor faulty/damaged.</li> <li>2. Wash motor contactor faulty.</li> </ol>	<ol style="list-style-type: none"> <li>1. Verify that the wash motor is getting power; if so, replace the motor.</li> <li>2. Check for continuity; if contacts are open, replace the contactor.</li> </ol>
Dishmachine runs continuously in the wash cycle.	<ol style="list-style-type: none"> <li>1. Machine is in Delime mode.</li> </ol>	<ol style="list-style-type: none"> <li>1. Select an automatic cycle by choosing I, II, or III on the controller display.</li> </ol>
Wash heater does not work.	<ol style="list-style-type: none"> <li>1. Faulty heater element.</li> <li>2. Faulty heater contactor.</li> </ol>	<ol style="list-style-type: none"> <li>1. Check element for continuity; if open, replace the heater.</li> <li>2. Replace the contactor.</li> </ol>
Dishmachine fills slowly and/or the rinse is weak.	<ol style="list-style-type: none"> <li>1. Clogged or obstructed rinse arms.</li> <li>2. Low incoming water pressure.</li> <li>3. Y-strainer is clogged</li> </ol>	<ol style="list-style-type: none"> <li>1. Remove and clean the rinse arms.</li> <li>2. Adjust the water pressure regulator to ensure that there is 10 PSI flow.</li> <li>3. Clean out the Y-strainer.</li> </ol>



**WARNING:** Inspection, testing, and repair of electrical equipment should only be performed by a qualified service technician. Many of the tests require that the unit have power to it and live electrical components be exposed. **USE EXTREME CAUTION WHEN TESTING THE MACHINE.**

PROBLEM	POSSIBLE CAUSE	REMEDY
No indication of pressure.	<ol style="list-style-type: none"> <li>1. Water turned off.</li> <li>2. Transducer disconnected.</li> <li>3. Pressure transducer defective.</li> </ol>	<ol style="list-style-type: none"> <li>1. Turn water on.</li> <li>2. Verify wiring.</li> <li>3. Replace pressure transducer.</li> </ol>
Wash water is not reaching required temperature.	<ol style="list-style-type: none"> <li>1. Faulty wash heater.</li> <li>2. Wash thermometer is defective.</li> </ol>	<ol style="list-style-type: none"> <li>1. Check element for continuity; if open, replace the heater.</li> <li>2. Replace thermometer.</li> </ol>
Doors will not close completely.	<ol style="list-style-type: none"> <li>1. Obstruction in door channel.</li> <li>2. Machine not level.</li> </ol>	<ol style="list-style-type: none"> <li>1. Remove the obstruction.</li> <li>2. Adjust the feet to level machine.</li> </ol>
Water leaks at the wash pump.	<ol style="list-style-type: none"> <li>1. Wash pump seal defective.</li> <li>2. Petcock or pump drain (if equipped) not shut/tight.</li> <li>3. Loose hoses (hose clamps) on the wash pump.</li> </ol>	<ol style="list-style-type: none"> <li>1. Replace the seal.</li> <li>2. Close or tighten.</li> <li>3. Tighten the hose clamps.</li> </ol>
Will not rinse.	<ol style="list-style-type: none"> <li>1. Defective rinse solenoid.</li> <li>2. Faulty timer.</li> <li>3. No water to the machine.</li> </ol>	<ol style="list-style-type: none"> <li>1. Repair or replace the rinse solenoid.</li> <li>2. Replace timer.</li> <li>3. Verify that there is water at 10 PSI connected to the machine.</li> </ol>
Dishes are not coming clean.	<ol style="list-style-type: none"> <li>1. Machine temperatures are not up to the minimum requirements.</li> <li>2. No detergent/too much detergent.</li> </ol>	<ol style="list-style-type: none"> <li>1. Verify that incoming water, rinse water, and wash water match the required temperatures as listed on the machine data plate.</li> <li>2. Adjust detergent concentration as required for the amount of water held by the machine.</li> </ol>

## PROGRAM SELECTION MODE

To access Program Selection Mode, the unit should be on and preferably not in operation (accessing this mode during operation will interrupt the process).

The programming Keys (Up-arrow, Down-arrow, and Select) are hidden on the display and are shown below outlined with red dots.

1. Press and hold the I and II Keys until "Program" starts flashing (2 - 3 seconds).



2. Press the Select Key.
3. Use the Up-arrow Key to change the program number to "6."



4. Press the Select Key.
5. "Program" will flash.
6. Press the Delime Key to exit.



**SETUP MODE** *To access Setup Mode, the unit should be on and preferably not in operation (accessing this mode during operation will interrupt the process).*

1. Press and hold the Up-arrow and Down-arrow Keys until "Setup" starts flashing (2 - 3 seconds).

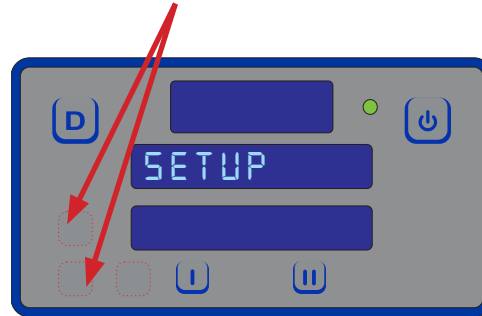

2. The display will then change to "Version" and show the firmware versions of the IO module and UI board.
3. Use the Up-arrow Key to cycle through the categories (will be flashing).
  - Language
  - Temperature Scale
  - Wash Temperature
  - Boost Temperature
  - Wash Offset
  - Rinse Offset
  - Boost Offset
  - Spare Offset



4. Press the Select Key to choose the category you want to change.
  - Regardless of the category, steps 5 - 7 remain the same.
5. Use the Up-arrow Key to change the options (will be flashing). Numerical options are shown in the top window.

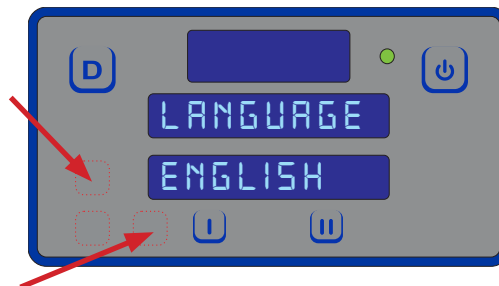

6. Press the Select Key to accept the changes.
7. Press the Delime Key to exit.

DISPLAY SHOWS	POSSIBLE CAUSES	REMEDY
"F4 Service needed," "Check incoming power"	<ol style="list-style-type: none"> <li>Incoming power not properly connected.</li> <li>L3 is missing (3-phase units only).</li> </ol>	<ol style="list-style-type: none"> <li>Check connections to heater.</li> <li>Verify that L3 is present and connected properly.</li> </ol>
"F6 Service needed," "No water in wash tank"	<ol style="list-style-type: none"> <li>Low or no water pressure.</li> <li>Faulty inlet valve or fill relay.</li> <li>Contact to wash heater not turning off.</li> <li>Faulty temperature input (T1) on IO module.</li> <li>Faulty temperature probe (T1).</li> <li>Faulty float switch allows heaters to operate with no water in tub.</li> </ol>	<ol style="list-style-type: none"> <li>Verify incoming water pressure is 8–12 PSI.</li> <li>Verify that fill relay is supplying voltage to fill solenoid. Replace faulty component.</li> <li>Check for welded contacts. Verify that output from IO module turns off when above the set temperature.</li> <li>Substitute a 1.2 kΩ resistor for T1, and verify that wash heater turns off. If not, replace IO module.</li> <li>Verify that T1 resistance is correct with respect to temperature. (See Table 1.) If not, replace T1.</li> <li>Replace float switch.</li> </ol>
"F7 Service needed," "Check wash tank thermostat"	<ol style="list-style-type: none"> <li>Contact to wash heater not turning off.</li> <li>Faulty temperature input (P10) on IO module.</li> <li>Faulty temperature probe (T1).</li> </ol>	<ol style="list-style-type: none"> <li>Check for welded contacts. Verify that output from IO module turns off when above the set temperature.</li> <li>Substitute a 1.2 kΩ resistor for T1, and verify that wash heater turns off. If not, replace IO module.</li> <li>Verify that T1 resistance is correct with respect to temperature. (See Table 1.) If not, replace T1.</li> </ol>
"F8 No water in wash tank," "Check inlet water and door"	<ol style="list-style-type: none"> <li>Malfunction of fill solenoid or fill relay.</li> <li>Door is open, which inhibits fill mode.</li> <li>Faulty door switch.</li> </ol>	<ol style="list-style-type: none"> <li>Replace faulty solenoid or fill relay.</li> <li>Close door to activate door switch.</li> <li>Replace or adjust door switch.</li> </ol>
F11 Service needed—check wash tank thermostat	<ol style="list-style-type: none"> <li>Faulty temperature probe (T1).</li> </ol>	<ol style="list-style-type: none"> <li>Replace probe that connects to P10.</li> </ol>
F13 Communication error. Check 6-pin cable	<ol style="list-style-type: none"> <li>Loose connection in 6-pin cable between display board and IO module.</li> <li>Faulty 6-pin cable between display board and IO module.</li> <li>Faulty communication port on IO module or display board.</li> </ol>	<ol style="list-style-type: none"> <li>Fully disconnect 6-pin cable at each end, and reconnect each end until a click is heard.</li> <li>Inspect for broken wire or unseated terminal by gently pulling on each wire at each end of the cable. Reseat any loose terminals by inserting it fully into the housing using long-nosed pliers. Replace cable if broken wire is found.</li> <li>Temporarily substitute a verified good display board, and check if F13 message recurs. If so, repeat substitution with a good IO module.</li> </ol>

**TABLE 1: RESISTANCE-TO-TEMPERATURE VALUES**

R (kΩ)	°F
11.58	69.8
10.37	75.2
9.30	80.6
7.78	89.6
3.05	140.0
2.54	150.8
2.18	159.8
1.58	179.6
1.45	185.0
1.33	190.4
1.16	199.4
0.96	212.0

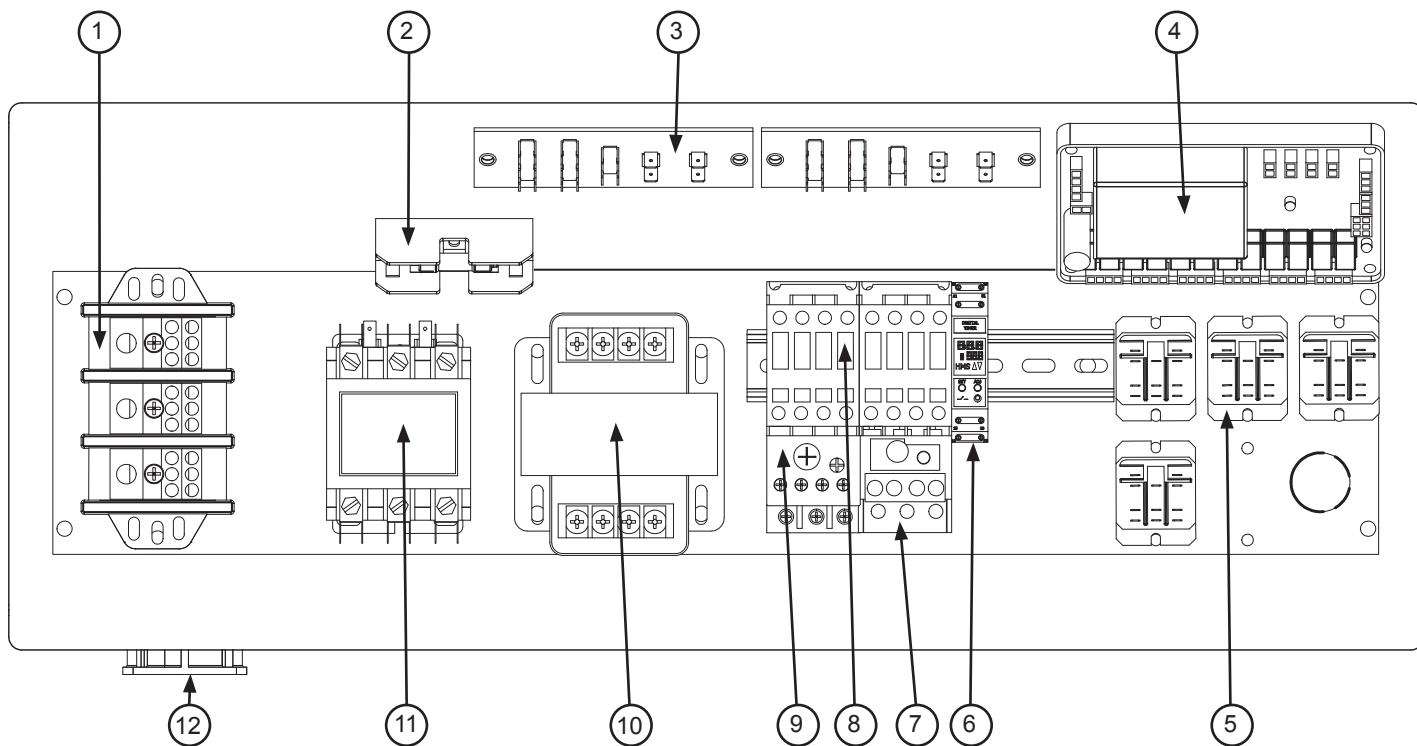

ITEM	QTY	DESCRIPTION	PART NUMBER
1	1	Terminal Block, 3-pole	05940-011-48-27
2	1	Fuse Holder	05920-011-72-89
3	2	Terminal Board	05940-002-78-97
4	1	PCB, Electronic Control	05945-004-26-34
5	4	Relay, KUP14AT5-120 P&B 3PO TP MO	05945-111-72-51
6	1	Timer, Universal Digital Multi-timer	05945-004-22-78
7	1	Overload	05945-111-68-40
8	2	Contactor, Wash Motor	05945-111-68-38
9	1	Overload	05945-111-68-39
10	1	Transformer, 208 V	05950-011-75-59
		Transformer, 230/460 V	05950-011-68-35
11	1	Contactor, CR353FE3AA1 3-pole 50A	05945-002-24-70
12	1	Fan	05999-004-30-62



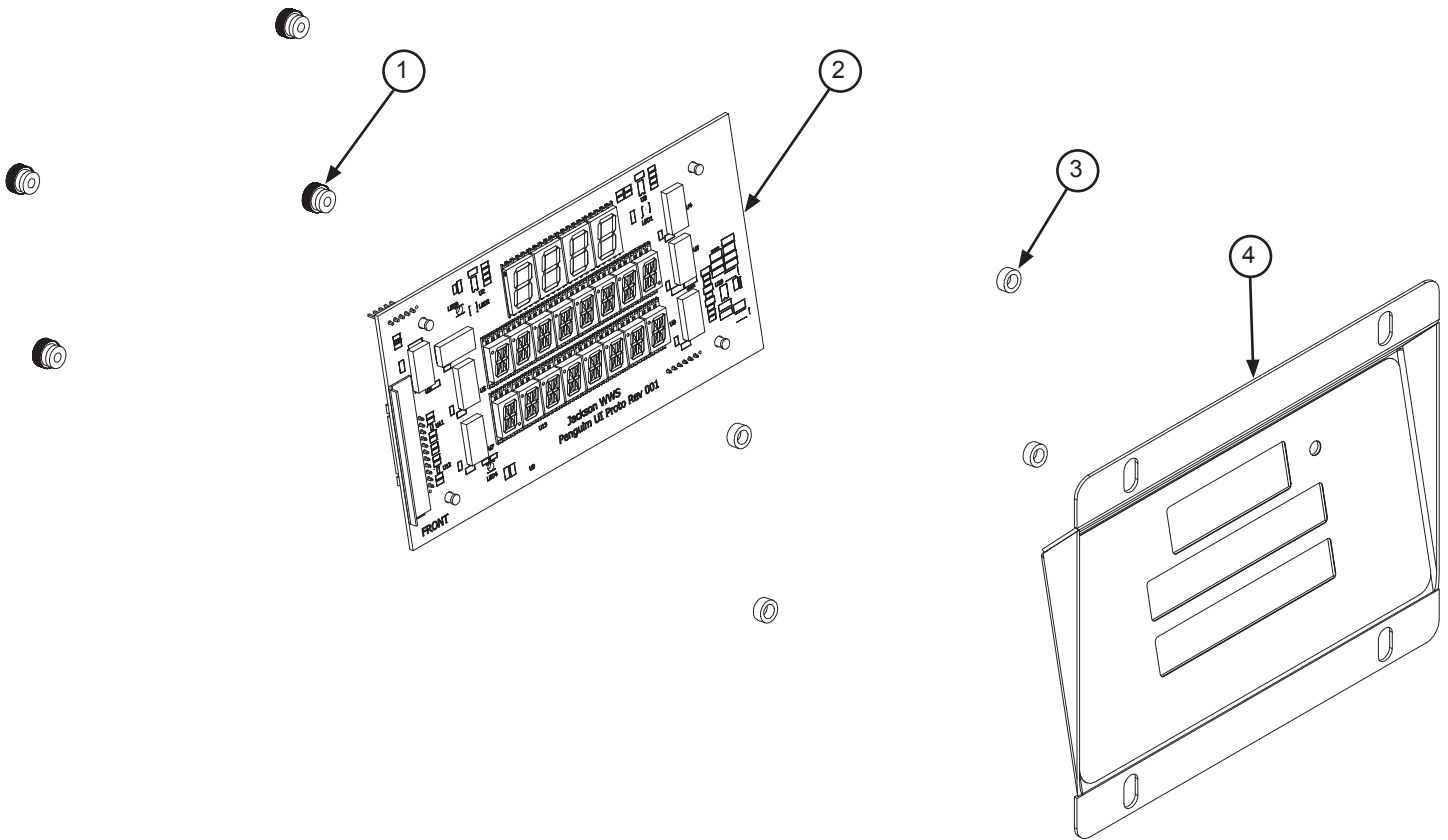

ITEM	QTY	DESCRIPTION	PART NUMBER
1	4	Nut, Thumb, 6-32 Nylon	05310-002-83-12
2	1	Board, Populated Circuit	05945-004-19-48
3	4	Spacer, Display Board	05999-004-19-75
4	1	Panel with Display Membrane	05700-004-40-08

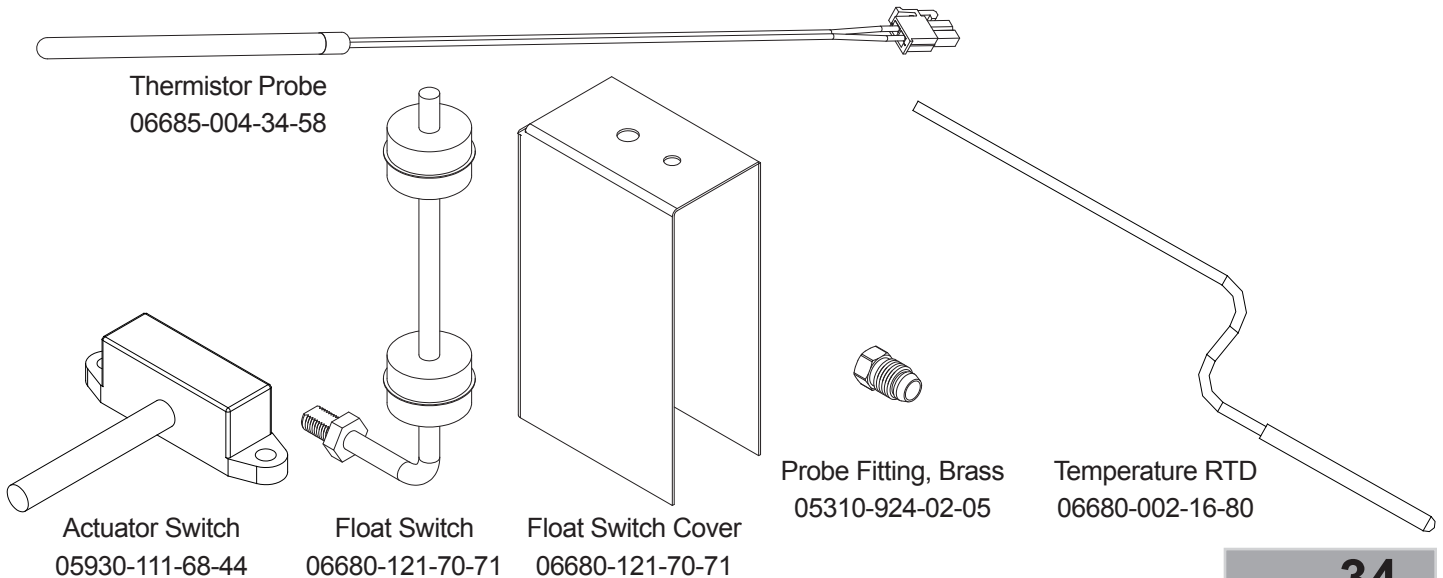

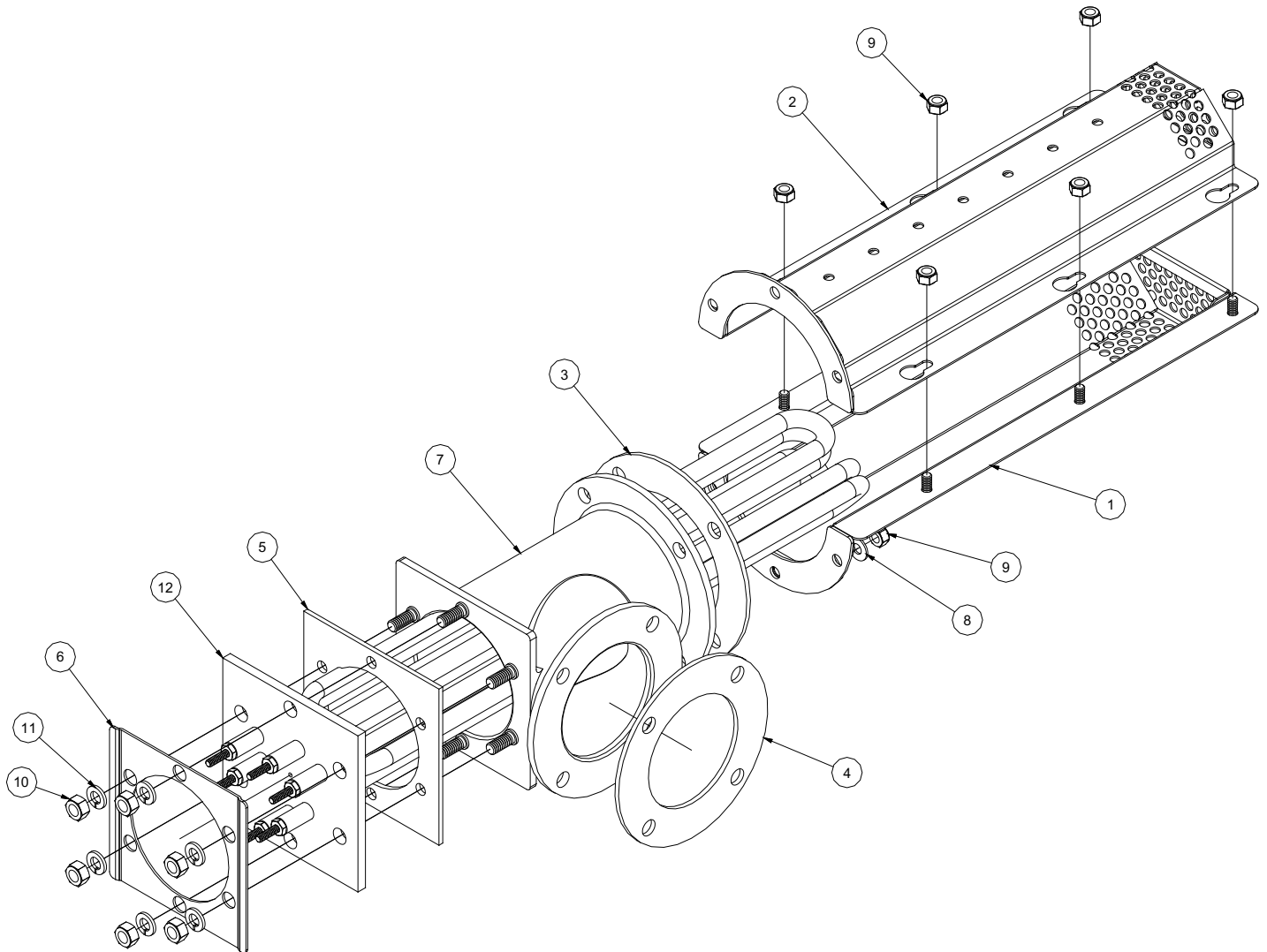

ITEM	QTY	DESCRIPTION	PART NUMBER
1	1	Heater Shroud Weldment Lower	05700-003-74-21
2	1	Heater Shroud Weldment Upper	05700-003-74-24
3	1	Gasket, Suction Casting	05330-003-75-89
4	1	Gasket, Pump Suction	05330-003-75-87
5	1	Gasket, Heater	05330-200-02-70
6	1	Heater Box Rails	05700-003-74-72
7	1	Wash Pump Suction Weldment	05700-003-77-63
8	2	Washer, S/S	05311-174-01-00
9	9	Locknut, 1/4"-20 Hex w/Nylon Insert	05310-374-01-00
10	6	Nut, Hex 5/16"-18 S/S	05310-275-01-00
11	6	Lockwasher, 5/16" Split S/S	05311-375-01-00
12	1	Wash Heating Element, 15kW/18kW	See Heater Chart

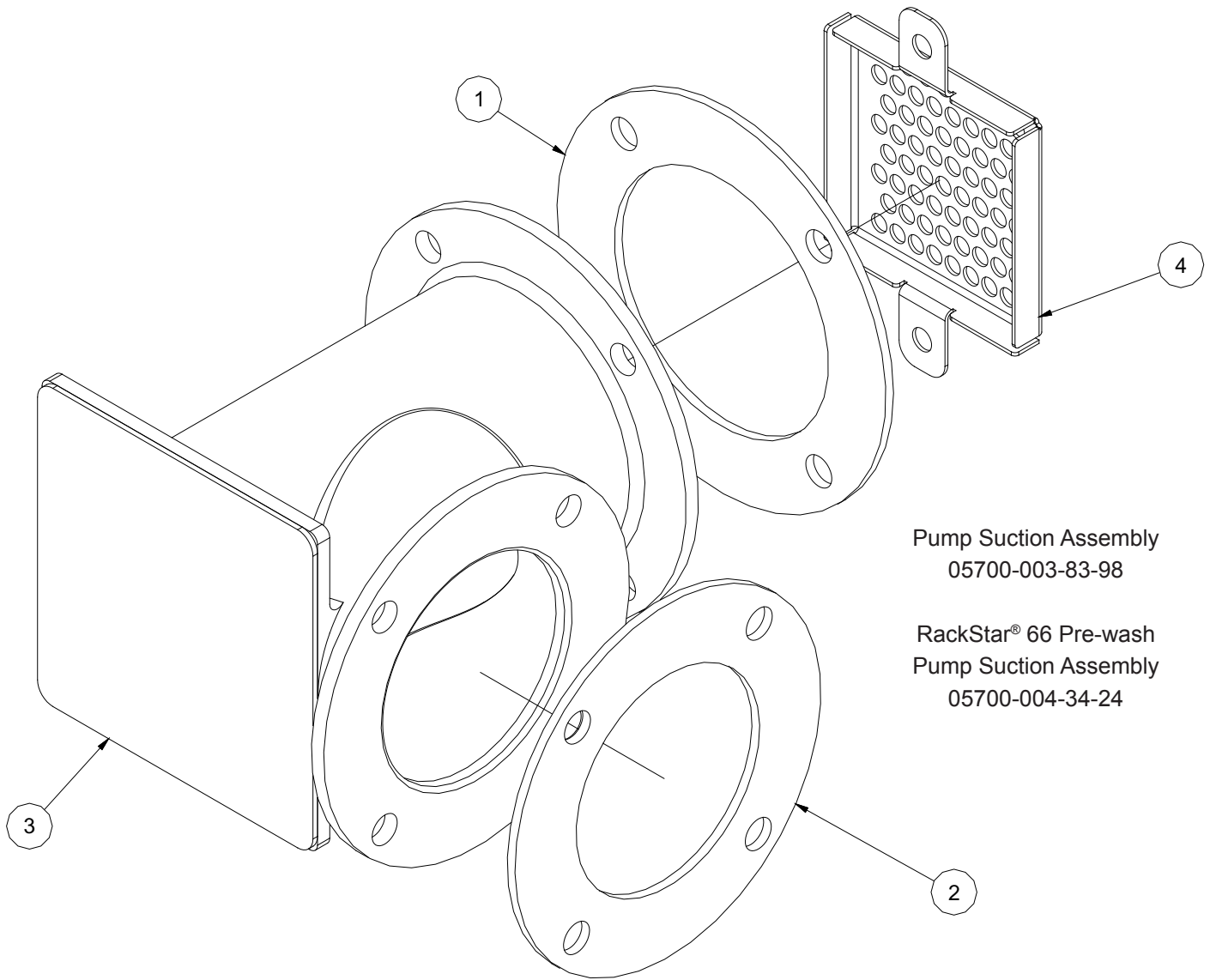

Pump Suction Assembly  
05700-003-83-98

RackStar® 66 Pre-wash  
Pump Suction Assembly  
05700-004-34-24

ITEM	QTY	DESCRIPTION	PART NUMBER
1	1	Gasket, Suction Casting	05330-003-75-89
2	1	Gasket, Pump Suction	05330-003-75-87
3	1	Pre-Wash Pump Suction Weldment	05700-003-82-27
4	1	Strainer, Pre-Wash Pump	05700-003-81-28

VOLTAGE	PHASE	KW	PART NUMBER	CONTACTOR
208	1	15	04540-121-68-45	05945-111-68-37
230	1	15	04540-121-68-46	05945-111-68-37
208	3	15	04540-121-68-45	05945-002-24-70
230	3	15	04540-121-68-46	05945-002-24-70
460	3	15	04540-121-68-47	05945-002-24-70
208	1	18	04540-121-79-30	05945-111-68-37
230	1	18	04540-121-79-31	05945-111-68-37
208	3	18	04540-121-79-30	05945-002-24-70
230	3	18	04540-121-79-31	05945-002-24-70
460	3	18	04540-121-79-32	05945-002-24-70

**SERVICE NOTES:** When replacing wash heaters, it is highly recommended to change the gasket as well. Once installed, gaskets become compressed and are subject to extreme temperature changes. Replacing the gasket with the heater might prevent future leaks.

The nuts used to secure the heater to the casting should be torqued to 16 in-lbs. After tightening, the unit should be allowed to heat up and operate normally for approximately 30 minutes. Secure power to the machine and check the nuts once more to verify they are torqued to 16 in-lbs.

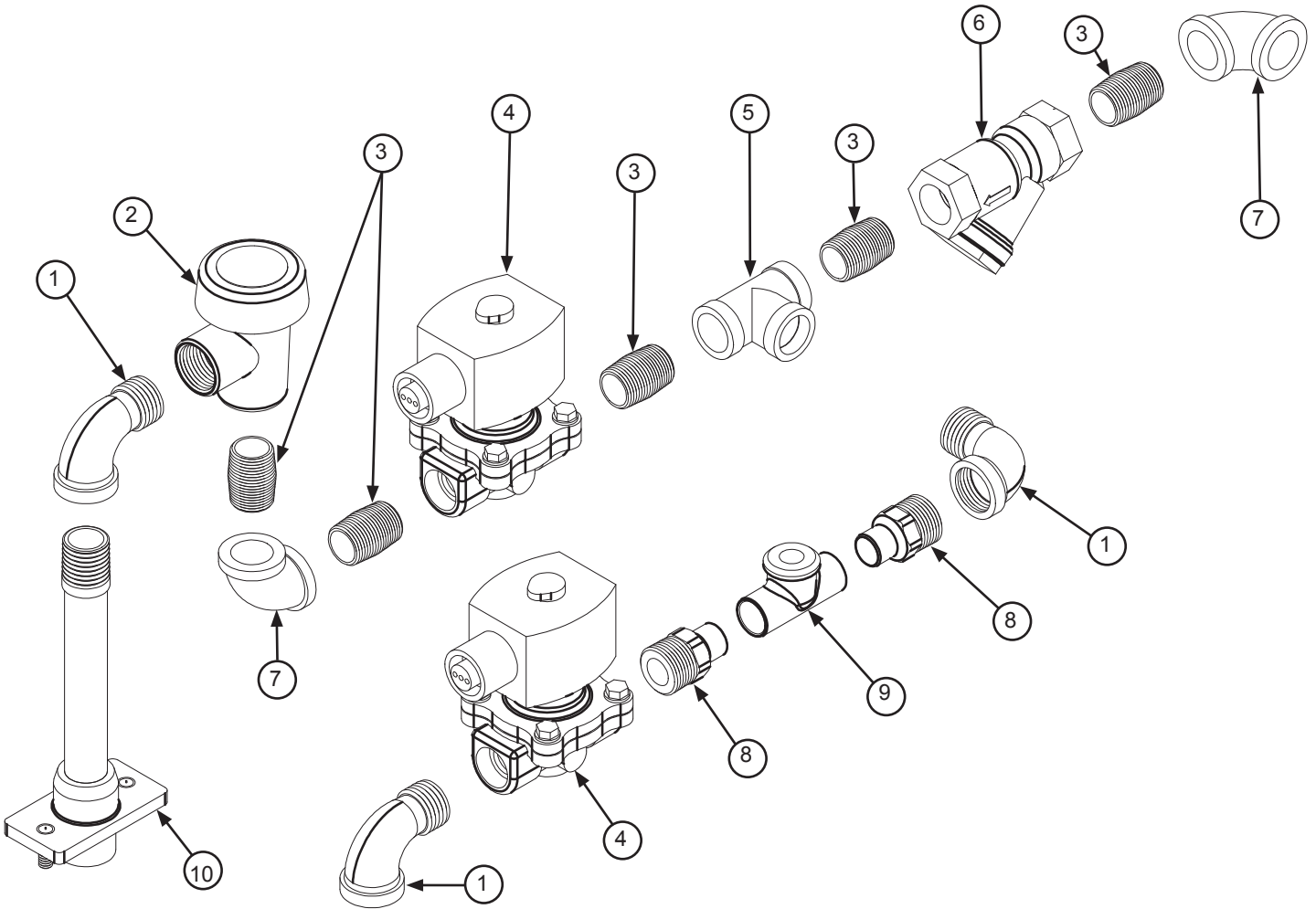

ITEM	QTY	DESCRIPTION	PART NUMBER
1	3	Elbow, 90-Degree 1/2 Street Brass	04730-206-08-00
2	1	Vacuum Breaker	04820-003-06-13
3	5	Nipple, 1/2 Close Brass	04730-207-15-00
4	2	Solenoid Valve, 1/2	04810-003-71-55
5	1	Tee, 1/2 Brass	04730-211-27-00
6	1	Y-strainer	04730-217-01-10
7	2	Elbow, 1/2 NPT	04730-011-42-96
8	2	Adapter, 1/2 Fitting X Male	04730-011-59-53
9	1	Tee, 1/2 X 1/2 X 1/4 Female	04730-411-25-01
10	1	Tank Fill Injector Weldment	05700-003-76-84

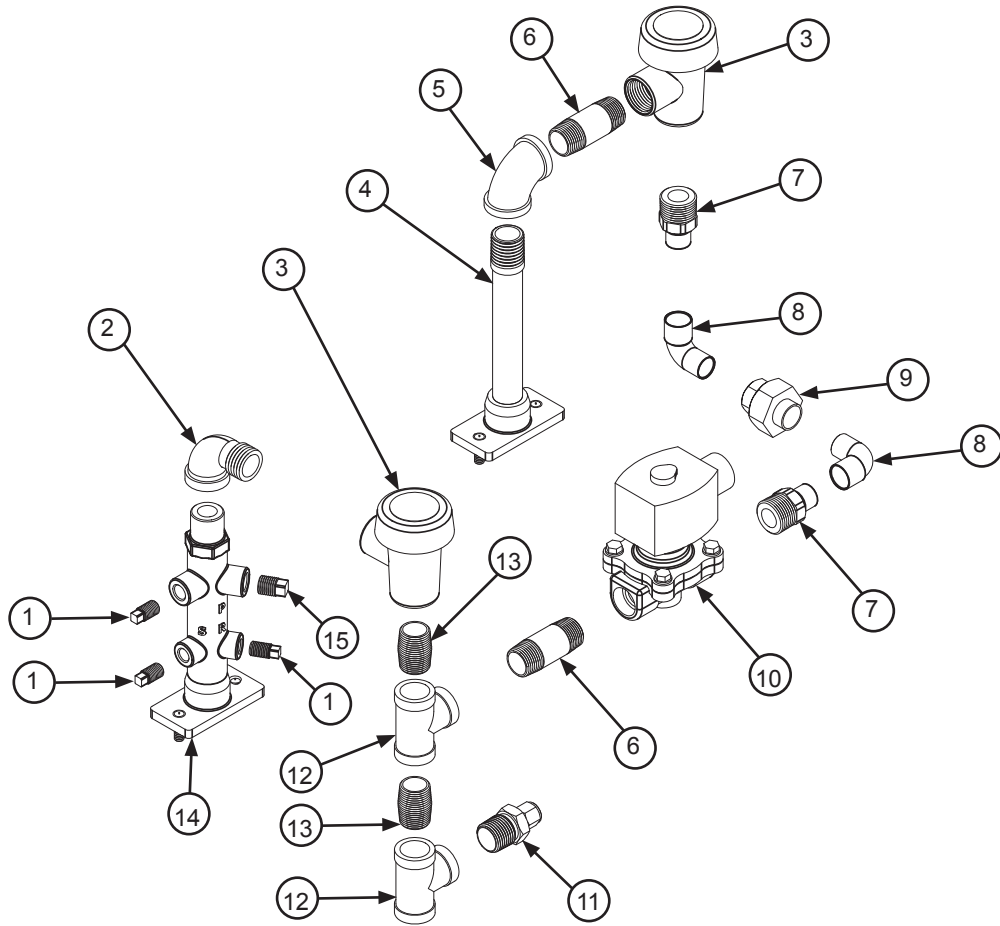

ITEM	QTY	DESCRIPTION	PART NUMBER
1	3	Plug, 1/8 Brass	04730-209-07-37
2	1	Elbow, 90-Degree 1/2 Street Brass	04730-206-08-00
3	2	Vacuum Breaker, 1/2"	04820-003-06-13
4	1	Injector, Turbo Rinse	05700-004-32-61
5	1	Elbow, 1/2 NPT Brass	04730-011-42-96
6	2	Nipple, 1/2 Brass 2 Long	04730-207-19-00
7	2	Adapter, 1/2 Fitting X Male	04730-011-59-53
8	2	Elbow, 1/2	04730-406-31-01
9	1	Union, 1/2	04730-412-05-01
10	1	Solenoid Valve, 1/2	04810-003-71-55
11	1	Fitting, Comp. 1/2 NPT X 1/4	05700-004-36-74
12	2	Tee, 1/2 Brass	04730-211-27-00
13	2	Nipple, 1/2 Close Brass	04730-207-15-00
14	1	Rinse Injector	05700-003-76-83
15	1	Plug, 1/4 Brass	04730-209-01-00

# PRE-WASH TANK FILL ASSEMBLY

## PARTS

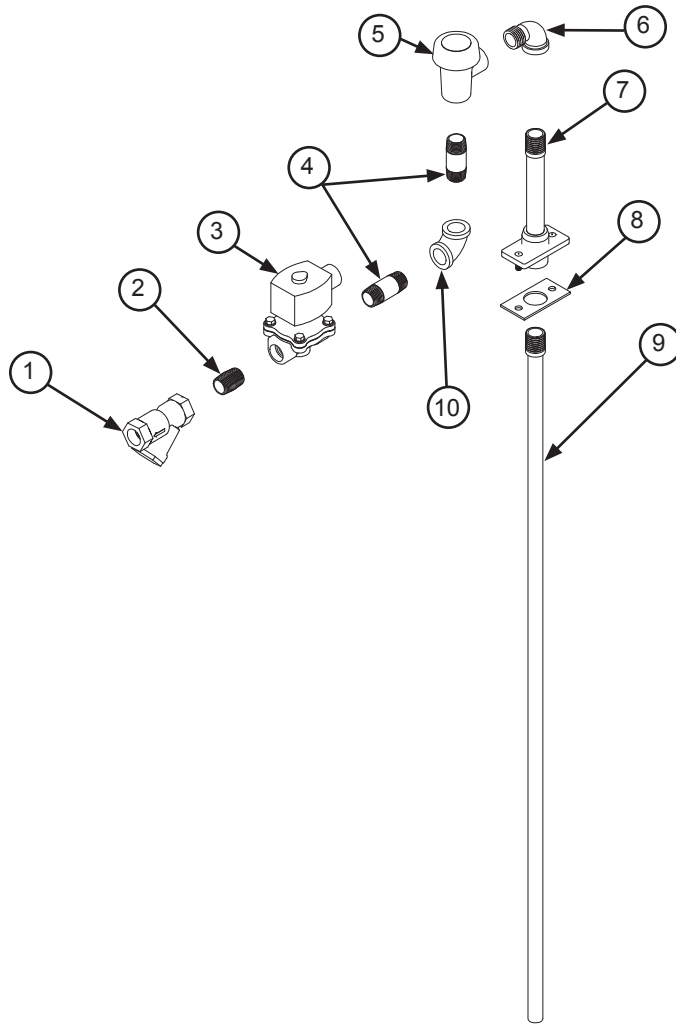

ITEM	QTY	DESCRIPTION	PART NUMBER
1	1	Y-strainer	04730-217-01-10
2	1	Nipple, 1/2" Close, Brass	04730-207-15-00
3	1	Valve, 1/2"	04810-003-71-55
4	2	Nipple, 1/2" Brass 2 Long	04730-207-19-00
5	1	Vacuum Breaker, 1/2"	04820-003-06-13
6	1	Elbow, 90-degree 1/2" Street Brass	04730-206-08-00
7	1	Wash Fill Injector	05700-003-77-56
8	1	Gasket, Rinse Manifold	05330-003-75-91
9	1	Tube, Tank Fill	05700-003-76-81
10	1	Elbow, 1/2" NPT 90 Brass	04730-011-42-96

# WASH MANIFOLD & ARM ASSEMBLY

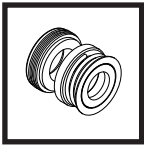
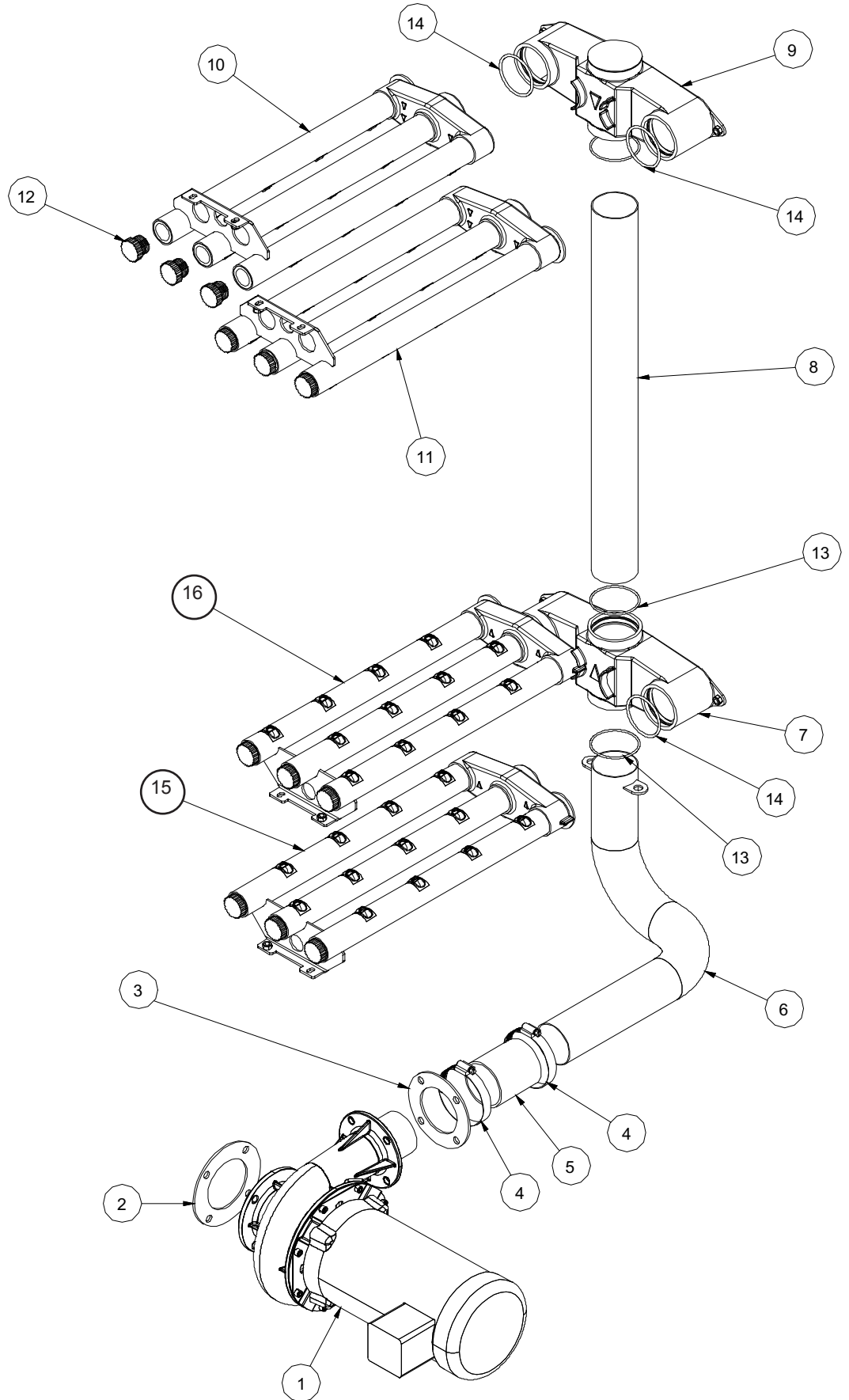

Mechanical Pump Seal  
05330-002-34-22



# WASH MANIFOLD & ARM ASSEMBLY

## PARTS

ITEM	QTY	DESCRIPTION	PART NUMBER
1	1	Pump & Motor Assembly	See Table Below
2	1	Gasket, Pump Suction	05330-003-75-87
3	1	Gasket, Pump Discharge	05330-003-75-88
4	2	Hose Clamp, Range 2-9/16" to 3-1/2"	04730-003-15-40
5	1	Hose, Wash Pump Discharge	05700-003-77-62
6	1	(L-R Machines) Lower Manifold (R-L Machines) Lower Manifold	05700-004-27-39 05700-004-30-27
7	1	Casting, Wash Manifold	09515-003-71-50
8	1	Tube, Manifold Riser	05700-003-72-37
9	1	Wash Manifold Weldment, Upper	05700-003-73-66
10	1	Wash Arm Weldment, Top-right	05700-003-75-79
11	1	Wash Arm Weldment, Top-left	05700-003-75-80
12	12	Cap, Threaded	04730-603-12-00
13	3	O-Ring, Silicone, .103 Dia., 2-1/2" x 2-11/16" OD	05330-003-73-71
14	4	O-Ring, Silicone, .139 Dia., 2-1/4" ID x 2-1/2" OD	05330-003-73-72
15	1	Wash Arm Weldment, Bottom-right	05700-004-27-43
16	1	Wash Arm Weldment, Bottom-left	05700-004-27-42

PUMP & MOTOR ASSEMBLY	PART NUMBER
Wash Pump, 3 HP, 208 V, 60 Hz, 3-Phase	06105-003-76-11
Wash Pump, 3 HP, 230 V, 60 Hz, 3-Phase	06105-003-76-11
Wash Pump, 3 HP, 460 V, 60 Hz, 3-Phase	06105-003-76-11
Wash Pump, 3 HP, 460 V, 60 Hz, 1-Phase	06105-003-76-13
Wash Pump, 3 HP, 230 V, 60 Hz, 1-Phase	06105-003-76-13

# PRE-WASH MANIFOLD & ARM ASSEMBLY

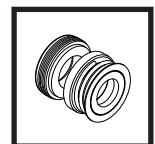
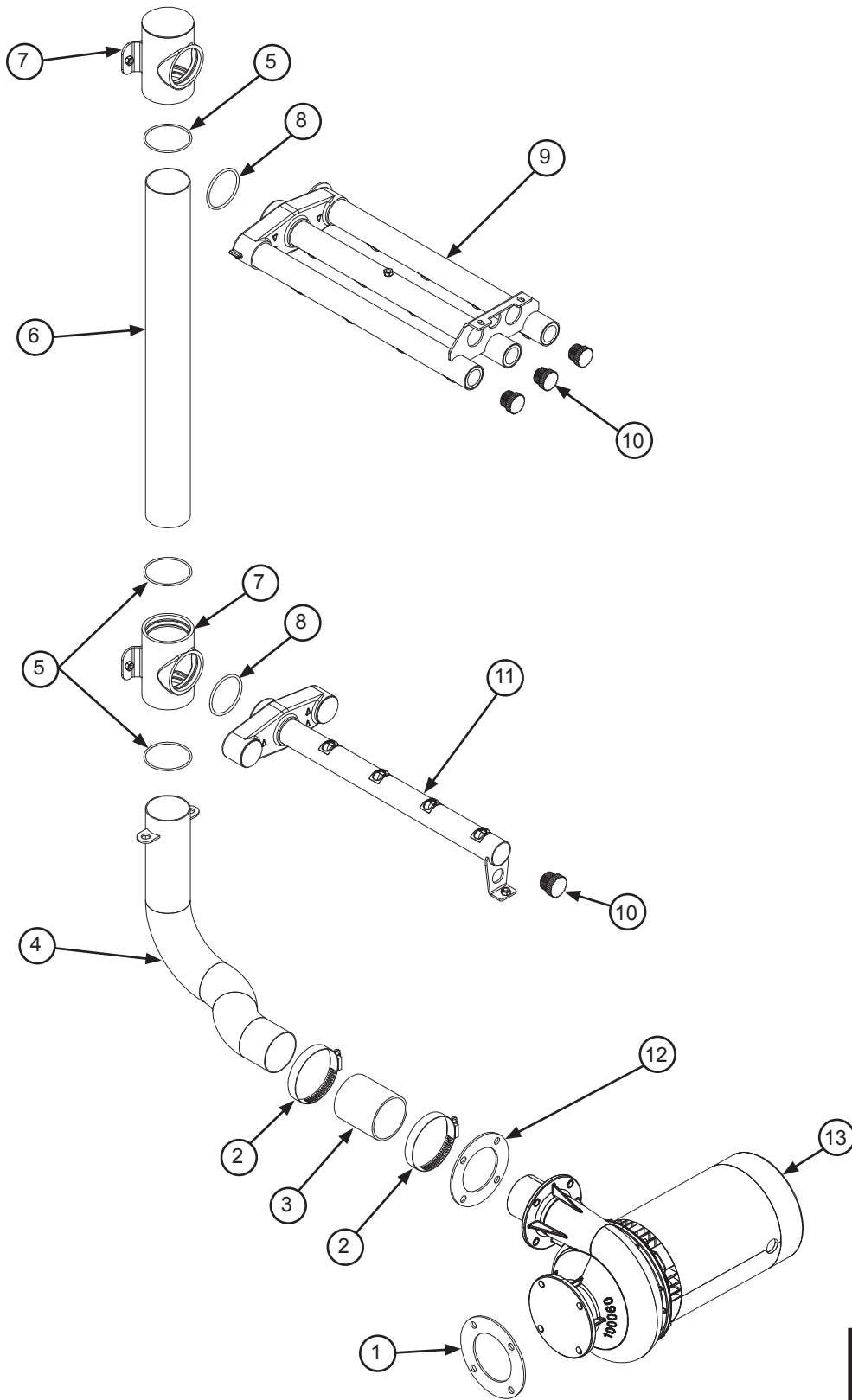

Mechanical Pump Seal  
05330-002-34-22

# PRE-WASH MANIFOLD & ARM ASSEMBLY

**PARTS**

ITEM	QTY	DESCRIPTION	PART NUMBER
1	1	Gasket, Pump Suction	05330-003-75-87
2	2	Hose Clamp	04730-003-15-40
3	1	Hose, Wash Pump Discharge	05700-003-77-62
4	1	Manifold, Pre-wash System	05700-004-31-60
5	3	O-Ring, Silicone, .103 Dia., 2-1/2" x 2-11/16" OD	05330-003-73-71
6	1	Tube, Manifold Riser	05700-003-81-53
7	2	Casting, Pre-wash Manifold	09515-003-77-22
8	2	O-Ring, Silicone, .139 Dia., 2-1/4" ID x 2-1/2" OD	05330-003-73-72
9	1	Pre-wash Arm	05700-003-75-79
10	4	Cap, Threaded	04730-603-12-00
11	1	Pre-wash Arm, Lower	05700-003-80-96
12	1	Gasket, Pump Discharge	05330-003-75-88
13	1	Pre-wash Motor	See Table Below

PUMP & MOTOR ASSEMBLY	PART NUMBER
Pre-Wash Pump, 2HP, 208V, 60Hz, 3-Phase	06105-003-76-12
Pre-Wash Pump, 2HP, 230V, 60Hz, 3-Phase	06105-003-76-12
Pre-Wash Pump, 2HP, 460V, 60Hz, 3-Phase	06105-003-76-12
Pre-Wash Pump, 2HP, 460V, 60Hz, 1-Phase	06105-003-76-14
Pre-Wash Pump, 2HP, 230V, 60Hz, 1-Phase	06105-003-76-14

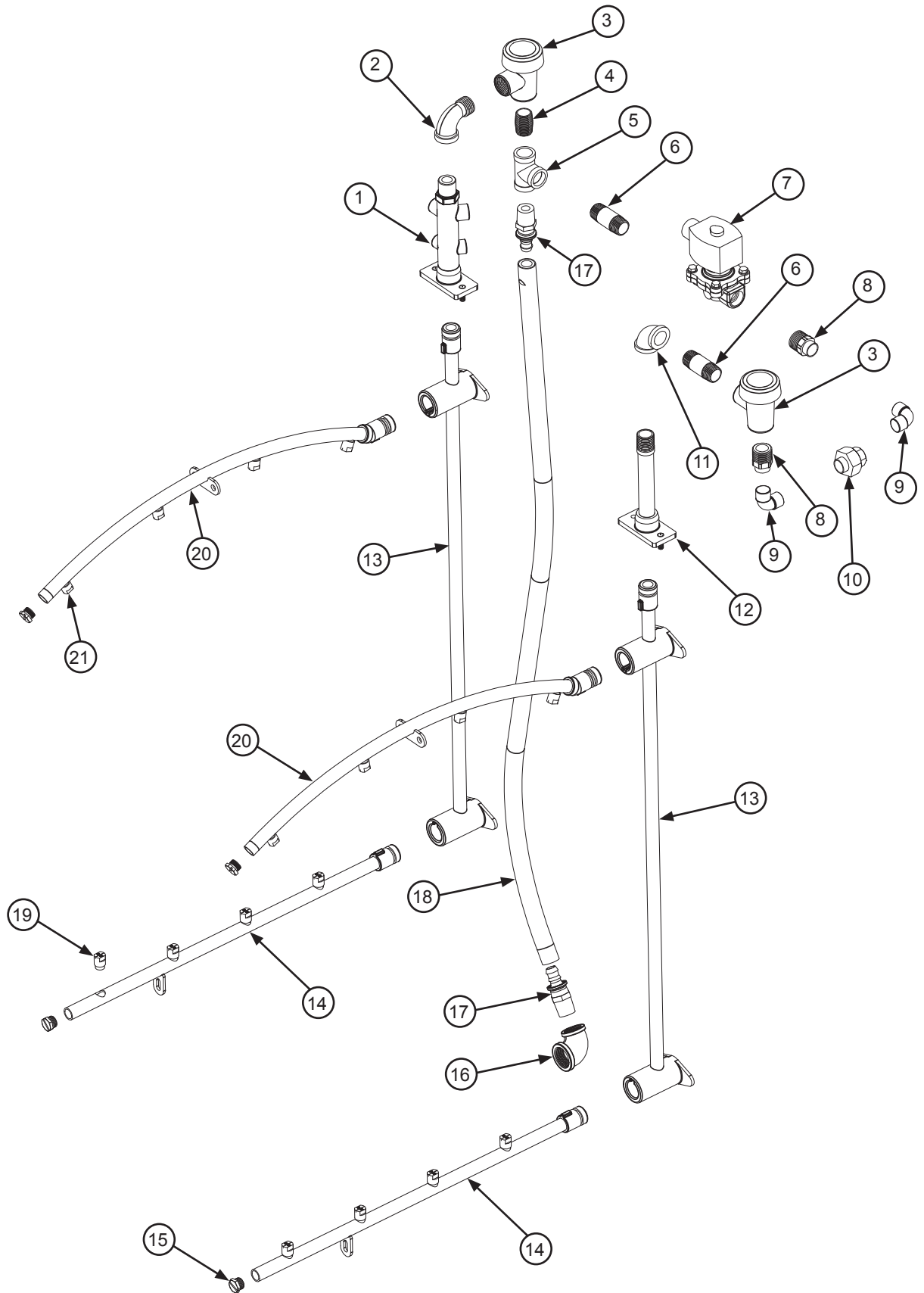

ITEM	QTY	DESCRIPTION	PART NUMBER
1	1	Rinse Injector	09515-003-73-35
2	1	Elbow, 90-degree 1/2 Street Brass	04730-206-08-00
3	2	Vacuum Breaker	04820-003-06-13
4	1	Nipple, 1/2 Close Brass	04730-207-15-00
5	1	Tee, 1/2 Brass	04730-211-27-00
6	2	Nipple, 1/2 Brass 2 Long	04730-207-19-00
7	1	Valve, 1/2"	04810-003-71-55
8	2	Adapter, Male	04730-401-03-01
9	2	Elbow, 607 1/2 IN CTOC	04730-406-01-01
10	1	Union, 1/2"	04730-412-05-01
11	1	Elbow, 1/2 NPT 90 Brass	04730-011-42-96
12	1	Fill Injector	05700-004-32-61
13	2	Rinse Manifold	05700-003-76-79
14	2	Lower Rinse Arm	05700-004-32-95
15	4	End-cap, Rinse Arm	05700-011-35-92
16	1	Elbow	04730-004-34-53
17	2	Fitting, 1/2" Male Swivel Brass	04730-004-19-62
18	1	Hose	05700-004-33-91
19	8	Nozzle, Lower Rinse Arm	04730-003-76-06
20	2	Upper Rinse Arm	05700-003-76-02
21	8	Nozzle, Upper Rinse Arm	04730-003-76-07

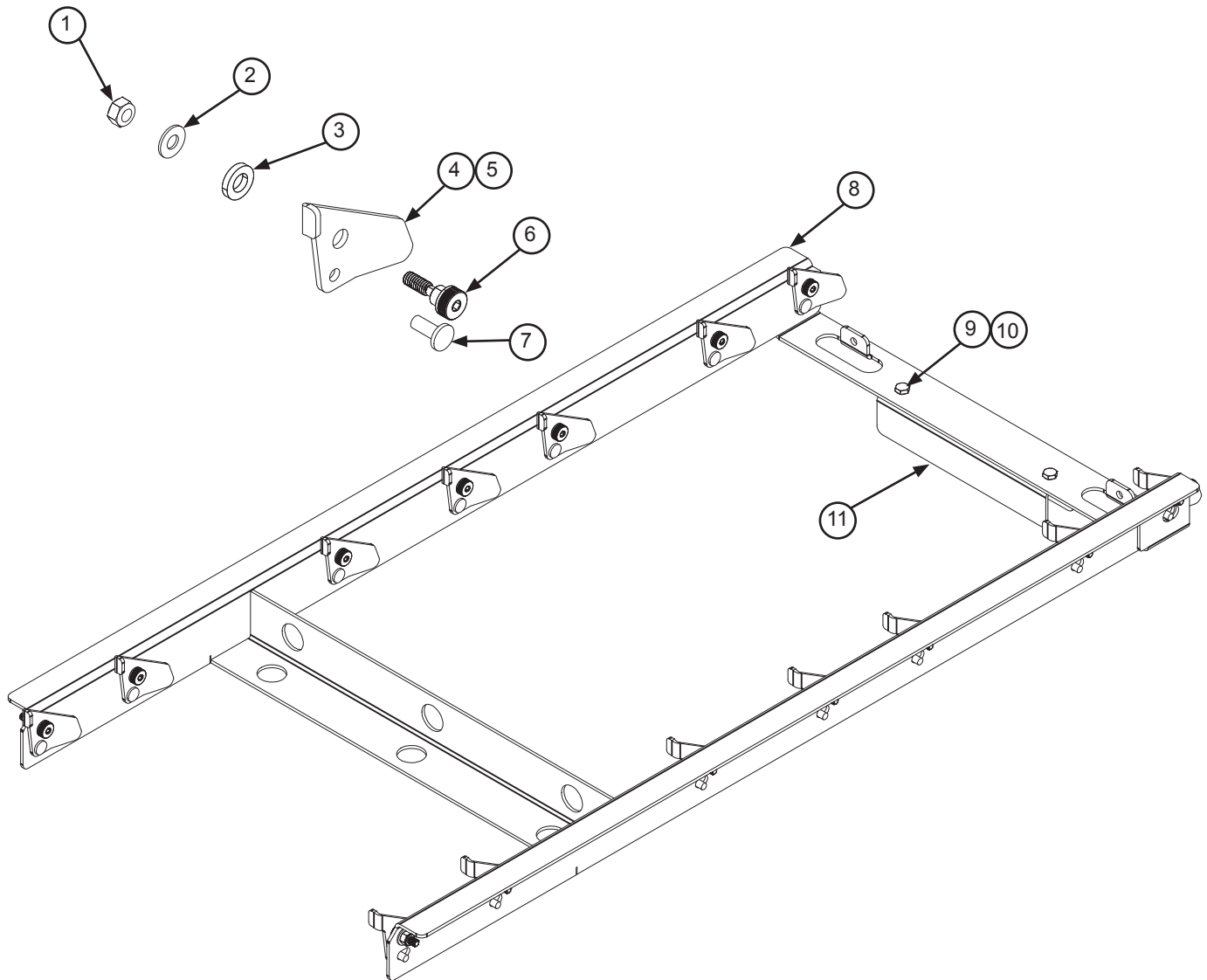

ITEM	QTY	DESCRIPTION	PART NUMBER
1	14	Locknut, 1/4-20 Hex w/Nylon Insert	05310-374-01-00
2	14	Washer, 1/4-20 I.D.	05311-174-01-00
3	14	Washer-Flat, .406 I.D. x .750 O.D.	05311-004-29-35
4	7	Rack Catch, Left	05700-004-15-70
5	7	Rack Catch, Right	05700-004-15-71
6	14	Bolt-Shoulder, 3/8 DIA. x 1/4", 1/4-20	05306-004-29-34
7	14	Rivet, Flat Head	05320-107-21-00
8	1	44" Pawl Bar Weldment	05700-004-17-74
9	2	Bolt, 1/4-20 x 1/2	05305-274-02-00
10	2	Nut, 1/4-20 x 1/2	05310-011-44-35
11	1	Rack Drive Guide	05700-004-11-80

# RACK PADDLE ASSEMBLY

## PARTS

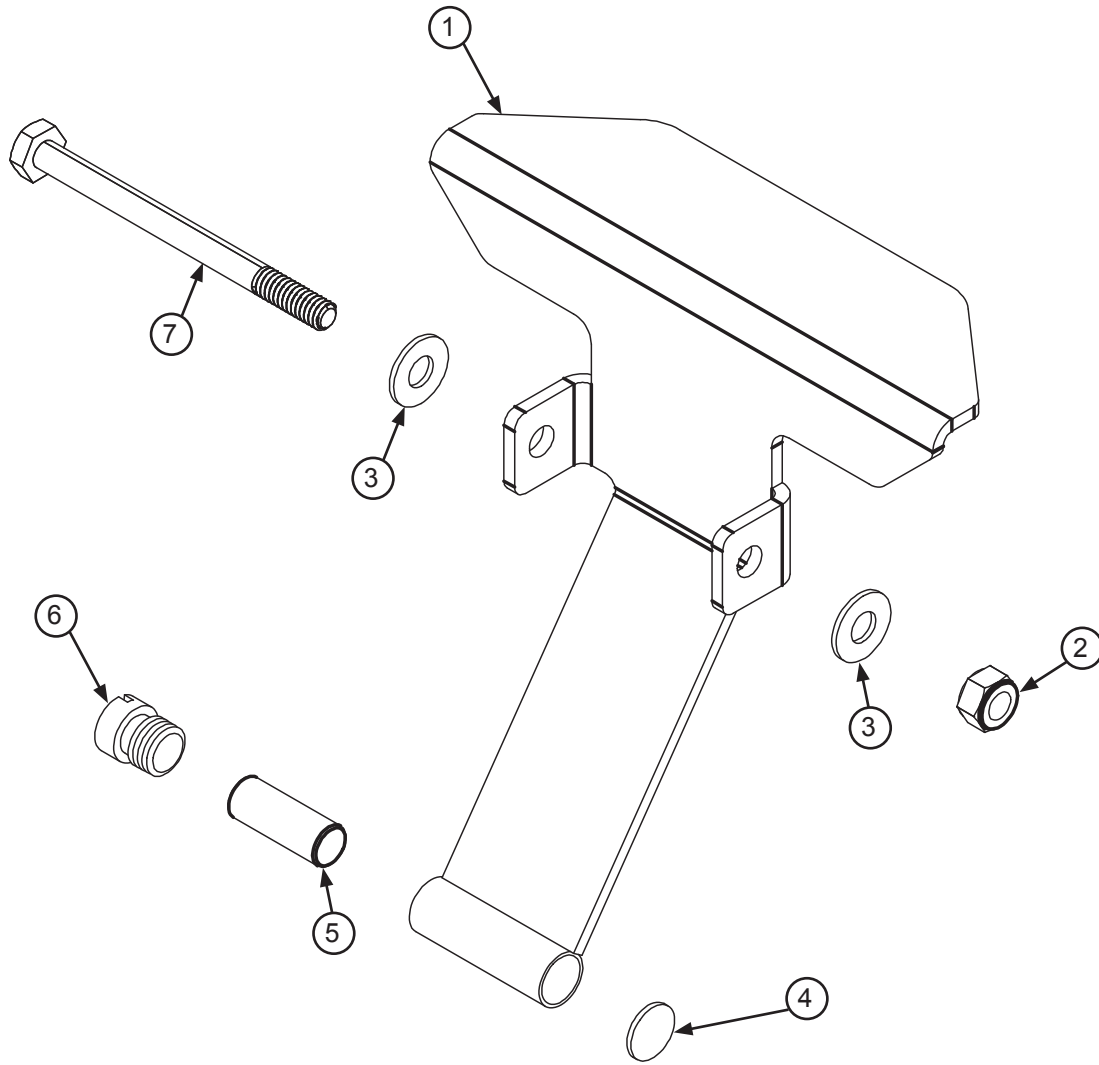

ITEM	QTY	DESCRIPTION	PART NUMBER
1	1	Paddle Switch	05700-004-26-89
2	1	Nut, Lock 1/4-20 Hex w/Nylon Insert	05310-374-01-00
3	2	Washer, 1/4-20 I.D.	05311-174-01-00
4	1	End-cap, Magnet Tube	05700-002-21-36
5	1	Magnet	05930-003-31-63
6	1	End-cap, Paddle Switch	05700-011-60-92
7	1	Bolt, Hex Head, 1/4-20 x 3-1/4"	05306-004-29-03

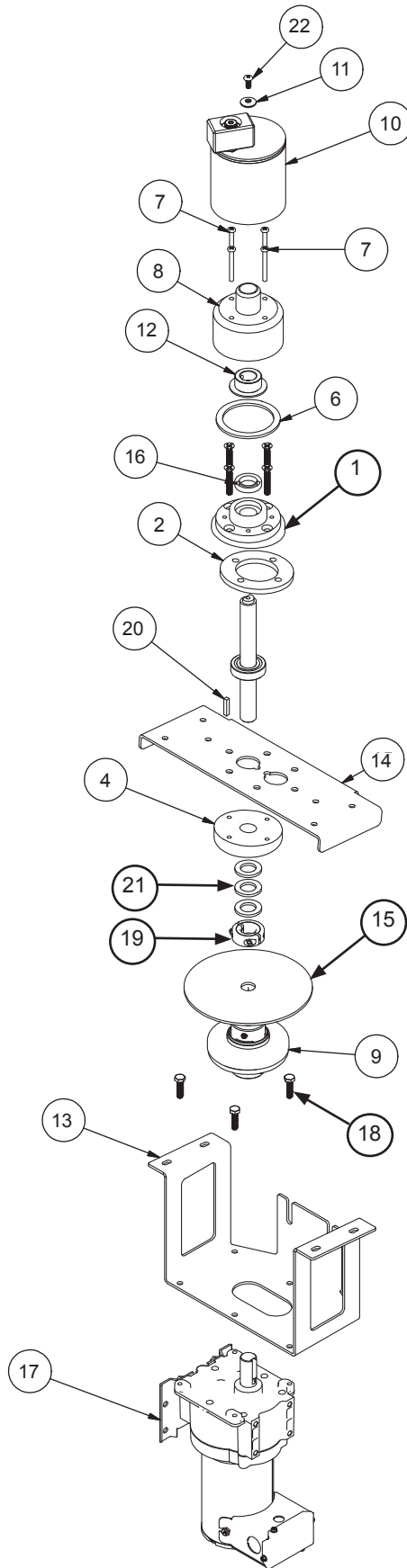

Drive Assembly  
05700-004-29-95



ITEM	QTY	DESCRIPTION	PART NUMBER
1	1	Drive Casting, Top	09515-004-17-06
2	1	Gasket, Drive Casting	05330-004-20-31
3	4	Screw, 1/4-20 x 1 1/2" Flat	05305-011-44-50
4	1	Drive Casting, Bottom	09515-004-17-03
5	1	Drive Shaft	05700-004-29-79
6	1	Gasket, Drain Seat	05700-002-04-42
7	4	Screw, 10-32 x 1 3/4"	05306-003-92-52
8	1	Drive Shaft Cover	05700-004-29-46
9	1	Clutch-Drive, 3/4" x 3/4"	06105-004-29-41
10	1	Drive Plate Cover	05700-004-29-49
11	1	Washer, Bonded Sealing 1/4" x 3/4"	05311-002-77-79
12	1	Collar, Shaft Drive	05700-004-29-45
13	1	Motor Plate	05700-004-19-38
14	1	Motor Support Plate	05700-004-26-97
15	1	Gasket, Clutch	05330-004-28-88
16	1	Seal, Viton Oil Shaft 3/4" ID	05330-004-29-06
17	1	Drive Motor	06105-004-29-53
18	4	Bolt, 1/4-28 x 1" S/S Hex Head	05306-004-30-91
19	1	Collar, Shaft 3/4" (Clamp-On)	03120-004-33-50
20	1	Key, 3/16" x 9/10" Long	05700-011-89-17
21	3	Bearing, Thrust 3/4" Shaft x 1-1/4" ID	03120-004-37-10
22	1	Sealing Pan Head Phillips	05305-004-26-70

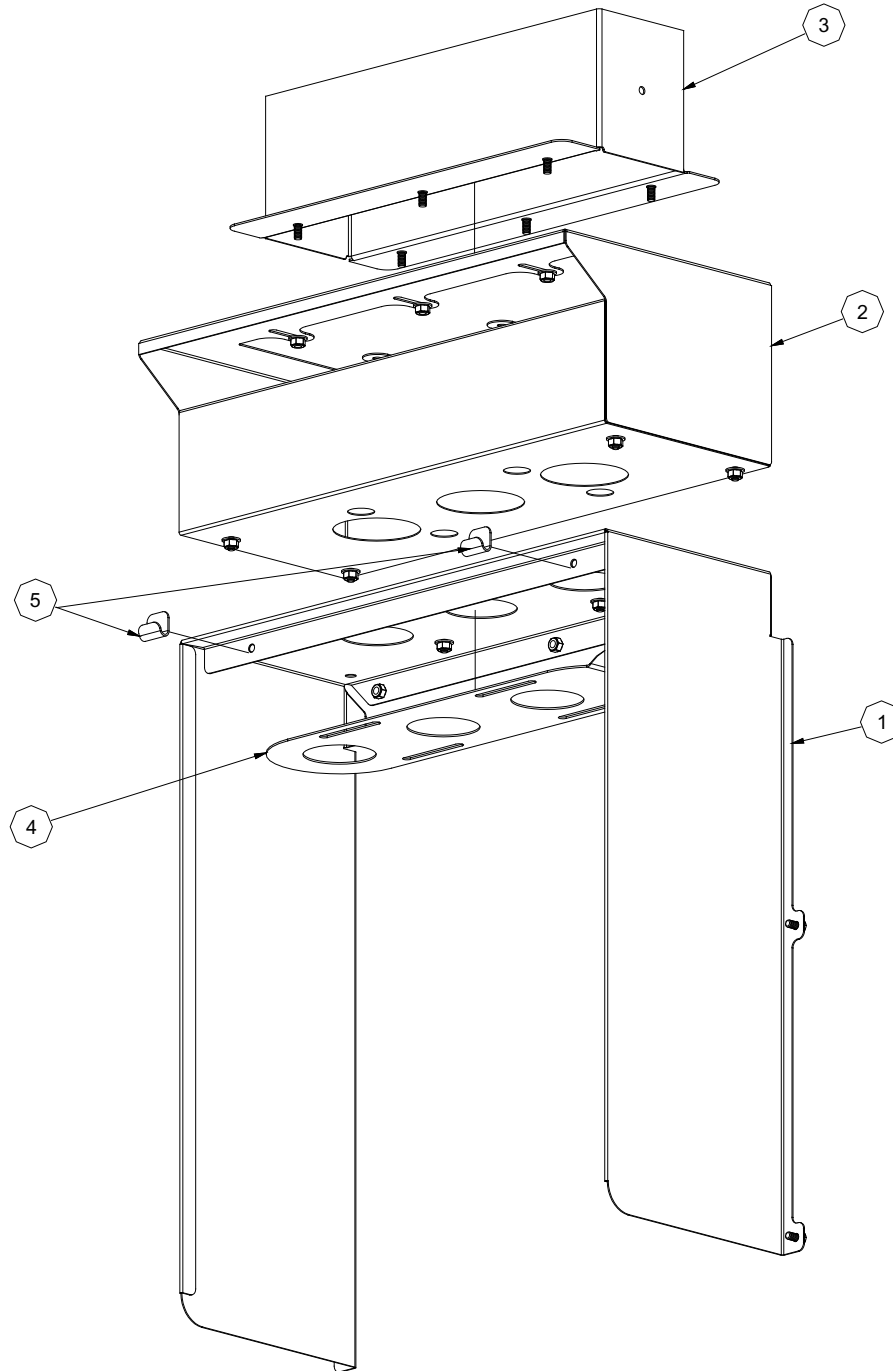

ITEM	QTY	DESCRIPTION	PART NUMBER
1	2	Ventilation Cowl	05700-004-34-01
2	2	Ventilation Scoop	05700-004-29-68
3	2	Ventilation Duct Adapter	05700-003-75-73
4	2	Damper, Ventilation Scoop	05700-003-74-76
5	4	Curtain Hook	05700-003-17-98

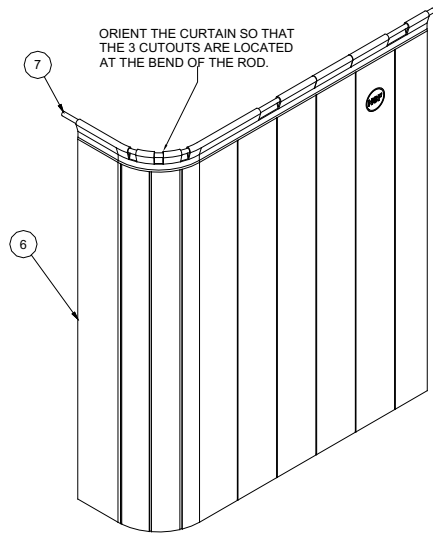
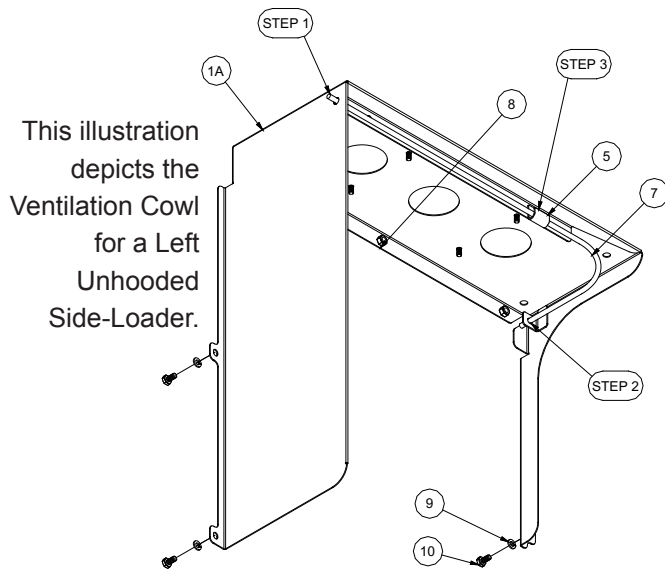

To attach the curtain and rod to the Ventilation Cowl, ensure that the curtain is oriented as depicted and follow the steps below:

1. Insert the rod into the hole at the rear of the Ventilation Cowl.
2. Insert the rod into the bracket at the front of the Ventilation Cowl.
3. Gently lift the rod at the curtain cutout over and onto the curtain hook ensuring that the ends of the rod stay inserted in the holes.

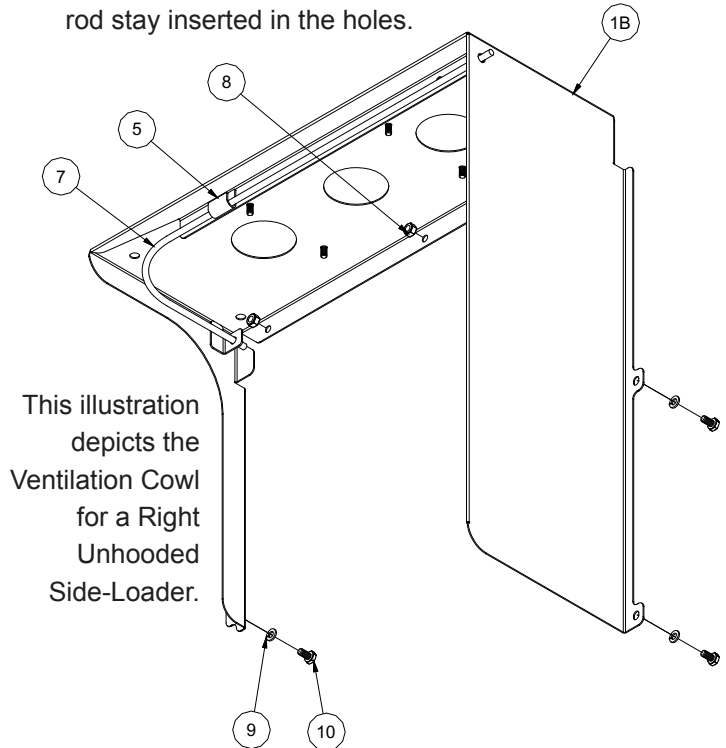

ITEM	QTY	DESCRIPTION	PART NUMBER
1A	1	Ventilation Cowl w/Cutout for Left Side Loader	05700-003-84-67
1B	1	Ventilation Cowl w/Cutout for Right Side Loader	05700-003-84-66
2	1	Ventilation Scoop (not shown)	05700-003-75-74
3	1	Ventilation Duct Adapter (not shown)	05700-003-75-73
4	1	Damper, Ventilation Scoop (not shown)	05700-003-74-76
5	2	Curtain Hook	05700-003-86-10
6	1	Curtain, XL for Side-Loader	08415-003-84-88
7	1	Curtain Rod	05700-003-84-57
8	3	Locknut, 1/4-20 Hex w/Nylon Insert	05310-374-01-00
9	3	Lockwasher, 1/4" Spring	05311-274-01-00
10	3	Bolt, 1/4-20 x 1/2" Long	05305-274-02-00

**WASH MOTORS:** Overloads are specified for 3-phase units only.

For GE brand MT03\* series overloads, the process for setting is as follows:

- Determine the Full Load Amps (FLA) for the wash motor.
- Set the overload at the closest setting without going over for the FLA of the motor.
- The overload already compensates for the FLA and will have a setpoint that is 125% of the FLA. (Example: Wash motor is rated at 10.0 FLA on the data plate. The replacement MT03\* overload will be set at 10.0. It will trip at 12.5 Amps.)

WASH MOTOR VOLTAGE	PART NUMBER	GE PART NUMBER
208	05945-111-68-40	RT1M
230	05945-111-68-40	RT1M

Blue selector switch should be set to H for manual reset.

**DRIVE MOTORS:** Overloads are specified for 3-phase units only.

For GE brand MT03\* series overloads, the process for setting is as follows:

- Determine the FLA for the drive motor.
- Set the overload at the closest setting without going over for the FLA of the motor.
- The overload already compensates for the FLA and will have a setpoint that is 125% of the FLA. (Example: Drive motor is rated at 1.0 FLA on the data plate. The replacement MT03\* overload will be set at 1.0. It will trip at 1.25 Amps.)

DRIVE MOTOR VOLTAGE	PART NUMBER	GE PART NUMBER
208	05945-111-68-39	RT1G
230	05945-111-68-39	RT1G

Blue selector switch should be set to H for manual reset.

**PRE-WASH MOTORS:** Overloads are specified for 3-phase units only.

For GE brand MT03\* series overloads, the process for setting is as follows:

- Determine the FLA for the pre-wash motor.
- Set the overload at the closest setting without going over for the FLA of the motor.
- The overload already compensates for the FLA and will have a setpoint that is 125% of the FLA. (Example: Pre-wash motor is rated at 6.0 FLA on the data plate. The replacement MT03\* overload will be set at 6.0. It will trip at 7.5 Amps.)

PRE-WASH MOTOR VOLTAGE	PART NUMBER	GE PART NUMBER
208	05945-003-76-28	MT03M
230	05945-003-76-28	MT03M
460	05945-003-76-26	MT03K

Blue selector switch should be set to H for manual reset.

**NOTE:** Connections should be tightened to 7 in-lbs.

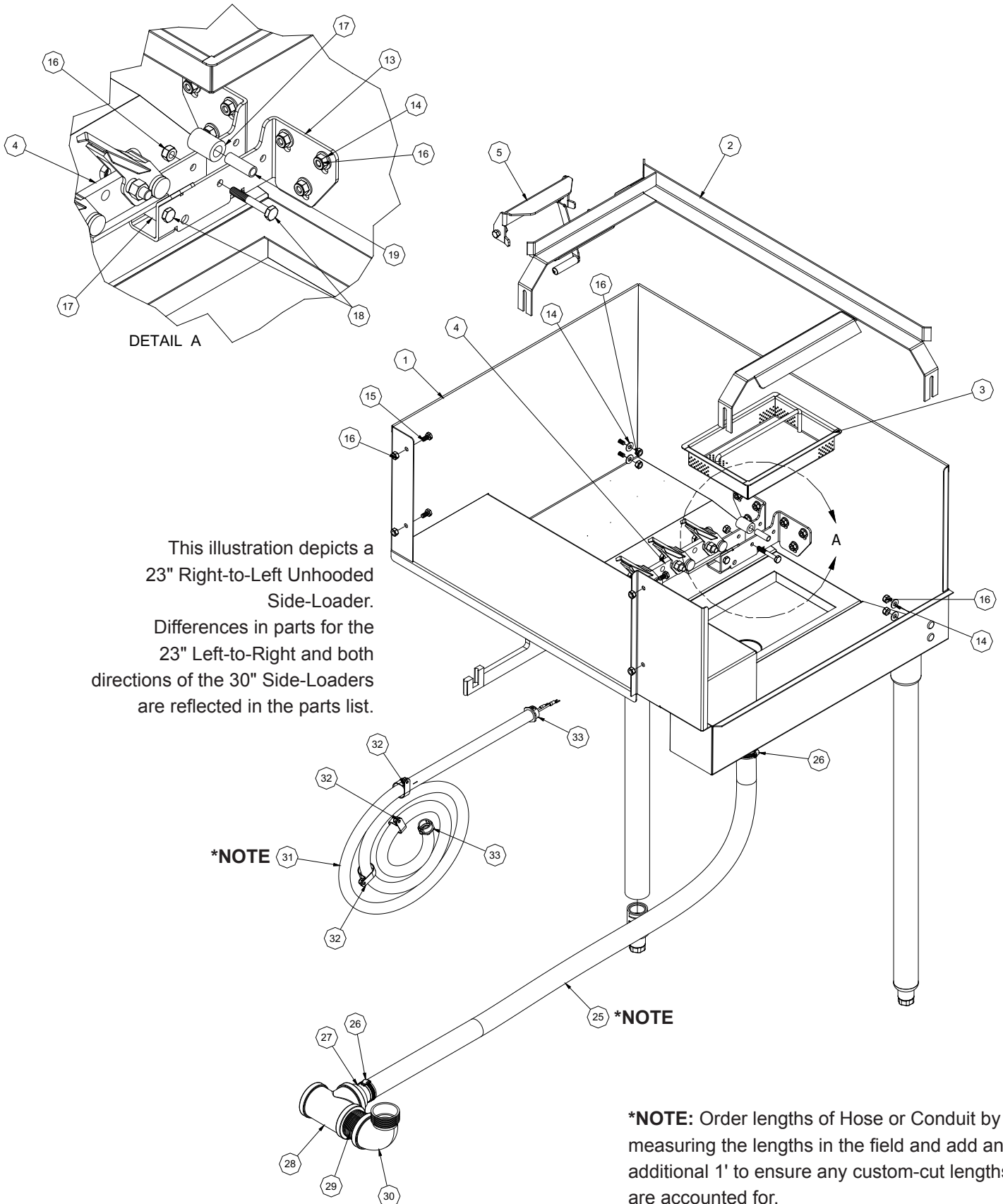

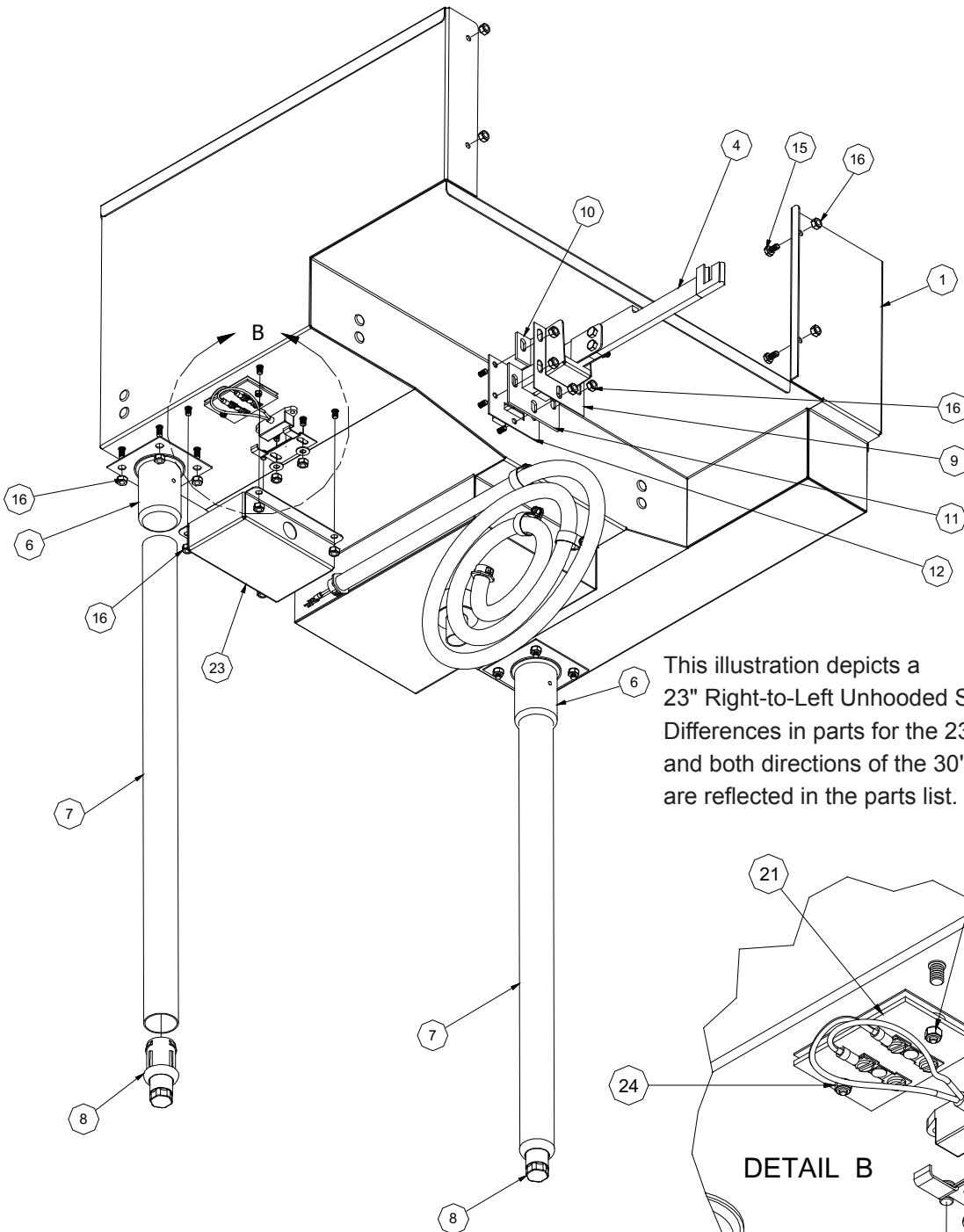

This illustration depicts a 23" Right-to-Left Unhooded Side-Loader. Differences in parts for the 23" Left-to-Right and both directions of the 30" Side-Loaders are reflected in the parts list.

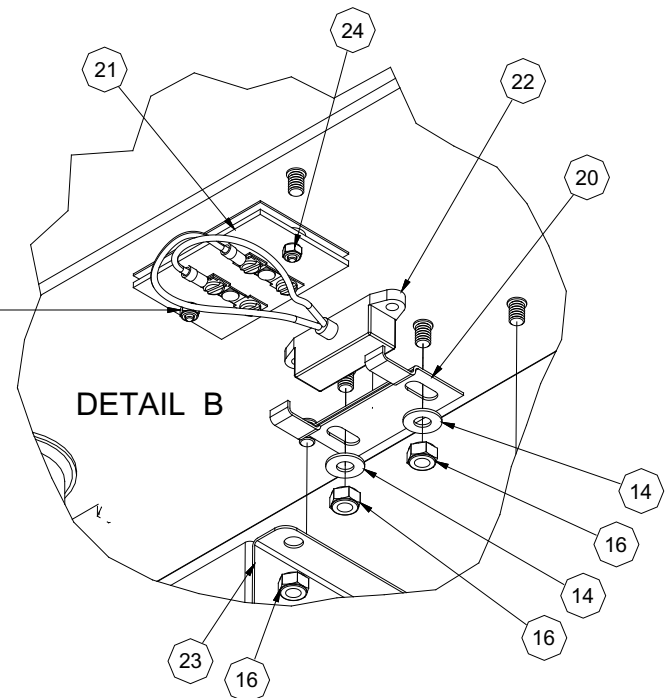

ITEM	QTY	DESCRIPTION	PART NUMBER
1	1	Tub Weldment, 23" Side-Loader L-R Tub Weldment, 23" Side-Loader R-L Tub Weldment, 30" Side-Loader L-R Tub Weldment, 30" Side-Loader R-L	05700-003-84-59 05700-003-84-58 05700-003-88-46 05700-003-88-39
2	1	Rack Support L-R	05700-003-90-00
3	1	Strainer	05700-021-85-10
4	1	Pawl Bar Drive Linkage (see side-loader drive linkage page)	05700-003-84-78
5	1	Actuator Switch Assembly	05700-003-89-96
6	2	Leg Socket	05700-002-56-14
7	2	Support Leg	05700-021-87-59
8	2	Foot, Adjustable	05340-108-01-03
9	1	Gutter, Pawl Bar	05700-021-66-86
10	1	Guide Block Top-Slotted	05700-011-69-49
11	1	Guide Block Bottom-Slotted	05700-011-69-50
12	1	Gasket, Drive Gutter	05330-011-68-55
13	1	Bracket, Loader Pawl Bar Support	05700-003-87-39
14	16	Washer, 1/4" S/S	05311-174-01-00
15	4	Bolt, 1/4-20 x 1/2" Long	05305-274-02-00
16	39	Locknut, 1/4-20 Hex w/Nylon Insert	05310-374-01-00
17	2	Roller	05700-011-68-16
18	2	SRackStar® , 1/4-20 x 1-3/4" Long Hex Head	05305-274-10-00
19	2	Roller Shaft	05700-011-68-14
20	1	Bracket, Limit Switch	05700-021-71-18
21	1	Terminal Board	05940-011-84-41
22	1	Switch Assembly, Side-Loader, 24VDC	05700-003-87-43
23	1	Cover, Side-Loader Switch	05700-003-87-41
24	2	Locknut, 6-32 Hex w/Nylon Insert	05310-373-03-00
25	*NOTE	Drain Hose, Polybraid 1" (*SEE NOTE ON PG. 54)	*04720-011-69-16
26	2	Hose Clamp (Range: 13/16" to 1-1/2")	04730-719-06-09
27	1	Drain Fitting Weldment	05700-021-84-61
28	1	Tee, 1-1/2" Brass	04730-011-69-93
29	1	Nipple, 1-1/2" Close Brass	04730-207-40-00
30	1	Elbow, 90 Deg Street, Brass 1-1/2"	04730-206-32-00
31	*NOTE	Conduit, 1/2" Flex 2 (*SEE NOTE ON PG. 54)	*05975-003-33-36
32	3	Clamp, 1" Nylon	04730-002-41-88
33	2	Fitting, 1/2" Straight Twist/Snap	05975-003-33-27

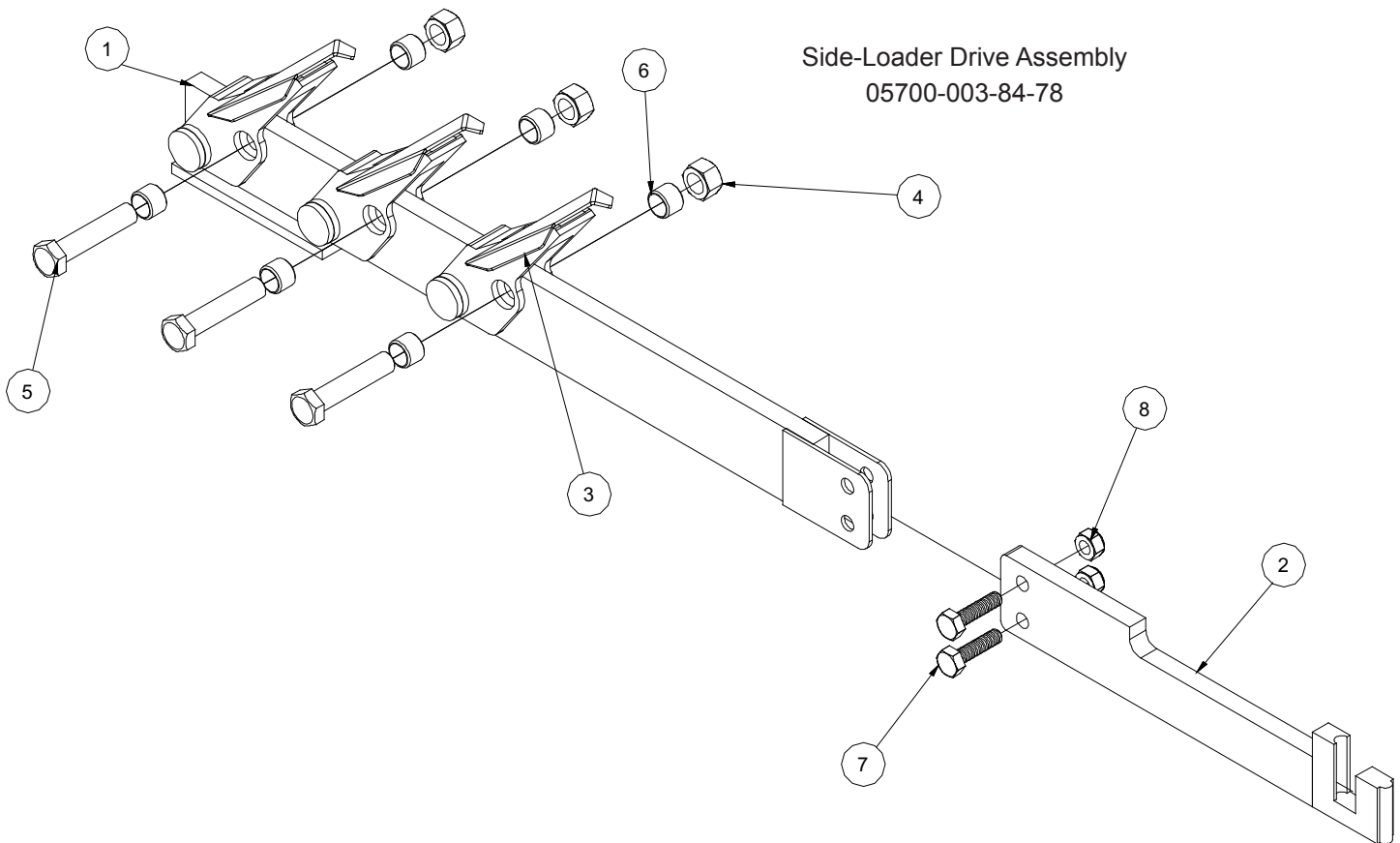

ITEM	QTY	DESCRIPTION	PART NUMBER
1	1	Pawl Bar, Side-Loader	05700-021-86-88
2	1	Drive Linkage, Side-Loader	05700-001-99-16
3	3	Pawl Dog w/Wing	05700-021-86-79
4	3	Locknut, 3/8-16 w/Nylon Insert	05310-011-72-55
5	3	Bolt, 3/8-16 x 1-3/4" Long Hex Head	05306-011-36-94
6	6	Spacer, Pawl Bar Dog	05700-011-71-45
7	3	SRackStar® , 1/4-20 x 1" Long Hex Head	05305-274-27-00
8	3	Locknut, 1/4-20 Hex w/Nylon Insert	05310-374-01-00



# STEAM-HEATING COIL ASSEMBLY

## PARTS

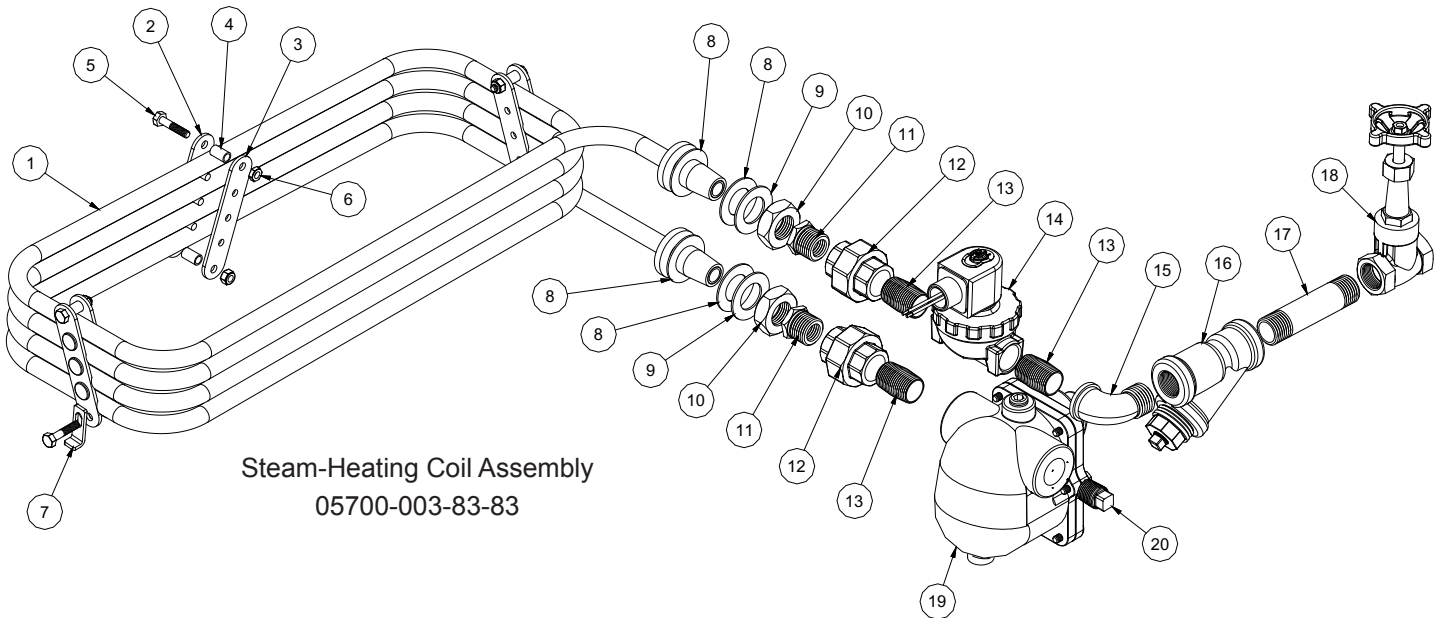

ITEM	QTY	DESCRIPTION	PART NUMBER
1	1	Steam Coil Weldment	05700-003-83-70
2	3	Steam Coil Spacer Weldment	05700-003-83-33
3	3	Plate, Steam Coil Spacer	05700-003-83-32
4	6	Sleeve, 1/4" x 5/8" Long	05700-003-83-35
5	6	Bolt, 1/4-20 x 1-1/4 Hex Head	05305-274-22-00
6	6	Locknut, 1/4-20 Low Profile w/Nylon Insert	05310-374-02-00
7	1	Bracket, Steam Coil Adjustment	05700-003-83-79
8	4	Gasket, Steam Coil	05700-001-17-86
9	2	Washer, Steam Coil Adapter	05700-001-17-87
10	2	Nut, Steam Coil Adapter	05310-011-17-85
11	2	Reducer, 3/4" x 1/2" Black Iron	04730-911-02-34
12	2	Union, 3/4" Black Iron	04730-912-01-00
13	3	Nipple, Close 3/4" Black Iron	04730-907-01-00
14	1	Valve, 3/4" Steam 110V Coil	04820-011-87-39
15	1	Elbow, 3/4" Street, Black Iron	04730-011-87-37
16	1	Y-Strainer, 3/4" Steam	04730-217-01-32
17	1	Nipple, 3/4" x 4" Long, Black Iron	04730-907-02-34
18	1	Valve, Gate 3/4" Steam	04820-100-19-00
19	1	Trap, Steam 3/4"	06680-500-02-77
20	1	Plug, 3/4" Square Head, Black Iron	04730-002-86-59

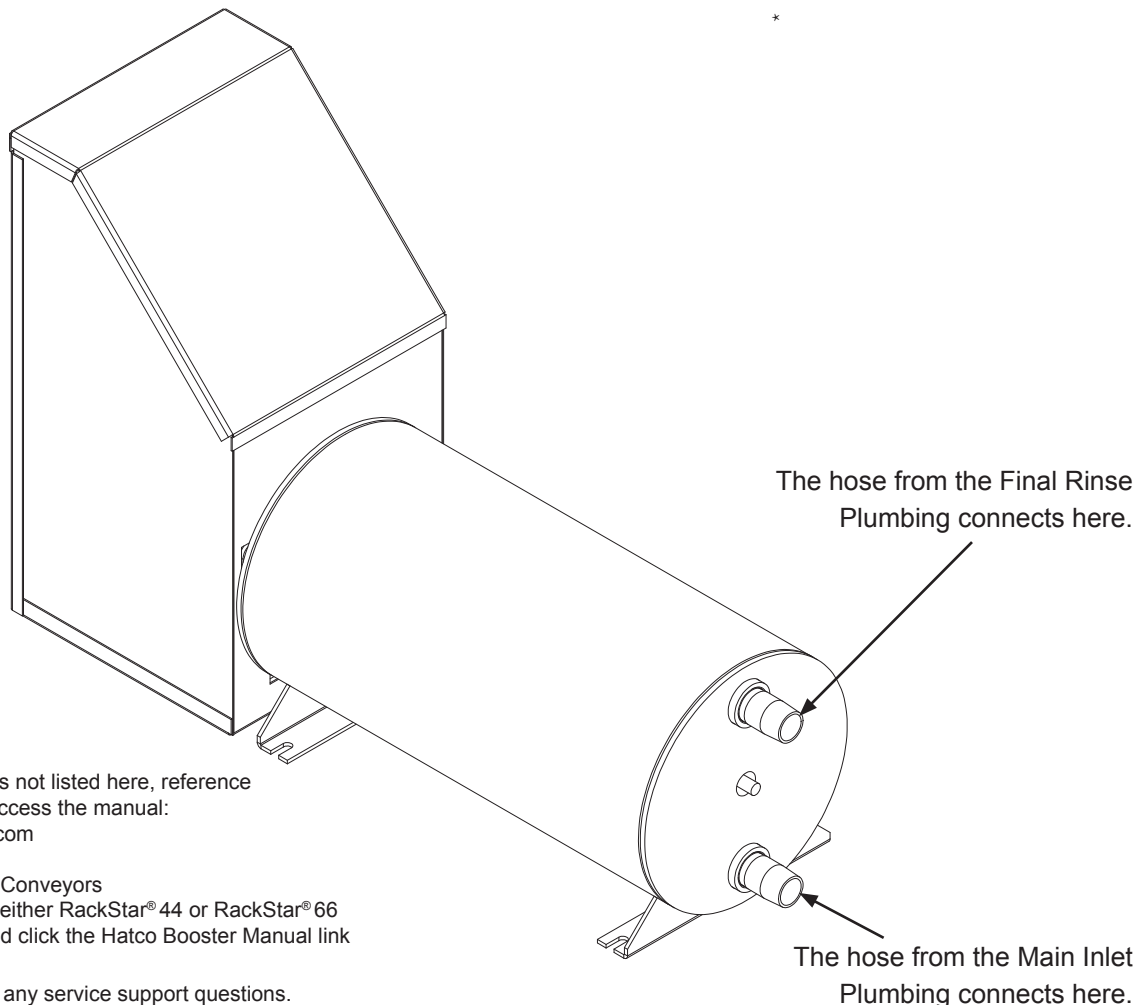

\*For Booster Heater service parts not listed here, reference the Hatco Booster Manual. To access the manual:

1. Go to [www.jacksonwws.com](http://www.jacksonwws.com)
2. Go to the Support page
3. Under Category, choose Conveyors
4. Under Products, choose either RackStar® 44 or RackStar® 66
5. Click View Resources and click the Hatco Booster Manual link

Call Hatco at 800-558-0607 with any service support questions.

ITEM	QTY	DESCRIPTION	PART NUMBER
1*	1	Booster Heater	See Chart Below

BOOSTER HEATER	PART NUMBER
12 kW (40 °F Rise) 208 V, 3-Phase	04540-004-30-83
12 kW (40 °F Rise) 240 V, 3-Phase	04540-004-30-82
12 kW (40 °F Rise) 480 V, 3-Phase	04540-004-30-81
12 kW (40 °F Rise) 208 V, 1-Phase	04540-004-30-80
12 kW (40 °F Rise) 240 V, 1-phase	04540-004-30-79
17 kW (70 °F Rise) 208 V, 3-Phase	04540-004-29-75
18 kW (70 °F Rise) 240 V, 3-Phase	04540-004-29-77
18 kW (70 °F Rise) 480 V, 3-Phase	04540-004-30-77
18 kW (70 °F Rise) 208 V, 1-Phase	04540-004-29-76
18 kW (70 °F Rise) 240 V, 1-Phase	04540-004-30-78

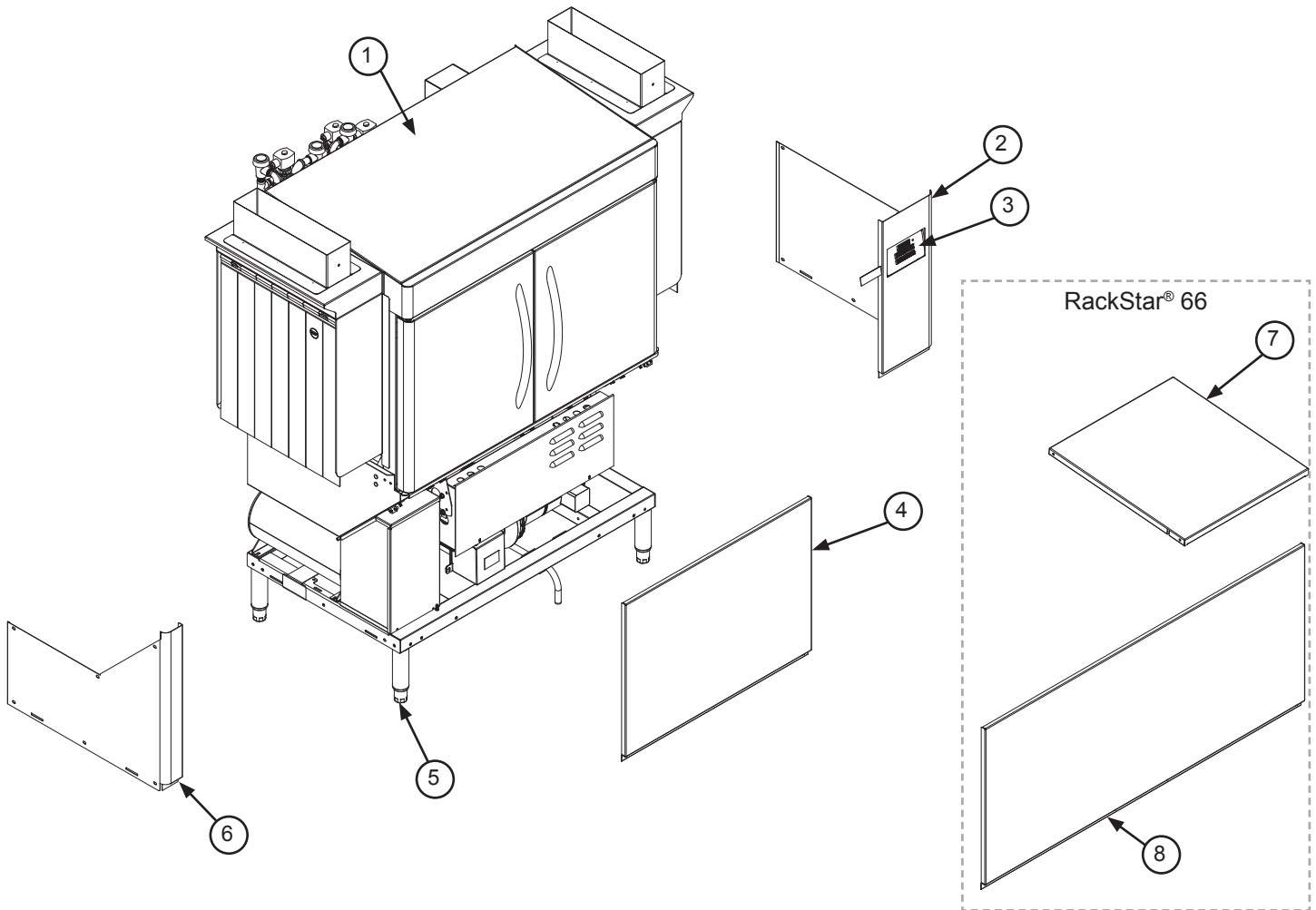

ITEM	QTY	DESCRIPTION	PART NUMBER
1	1	Hood Dress Panel	05700-004-18-39
2	1	Right Dress Panel, Right-to-Left Machine	05700-004-31-93
		Left Dress Panel, Left-to-Right Machine	05700-004-30-60
3	1	Display	See "Miscellaneous Electrical Components" page.
4	1	Front Dress Panel, RackStar® 44	05700-004-30-44
5	1	Adjustable Foot	05340-011-71-74
6	1	Left Dress Panel, Right-to-Left Machine	05700-004-31-92
		Right Dress Panel, Left-to-Right Machine	05700-004-30-59
7	1	Pre-wash Hood Dress Panel	05700-004-30-08
8	1	Front Dress Panel, RackStar® 66	05700-004-34-48

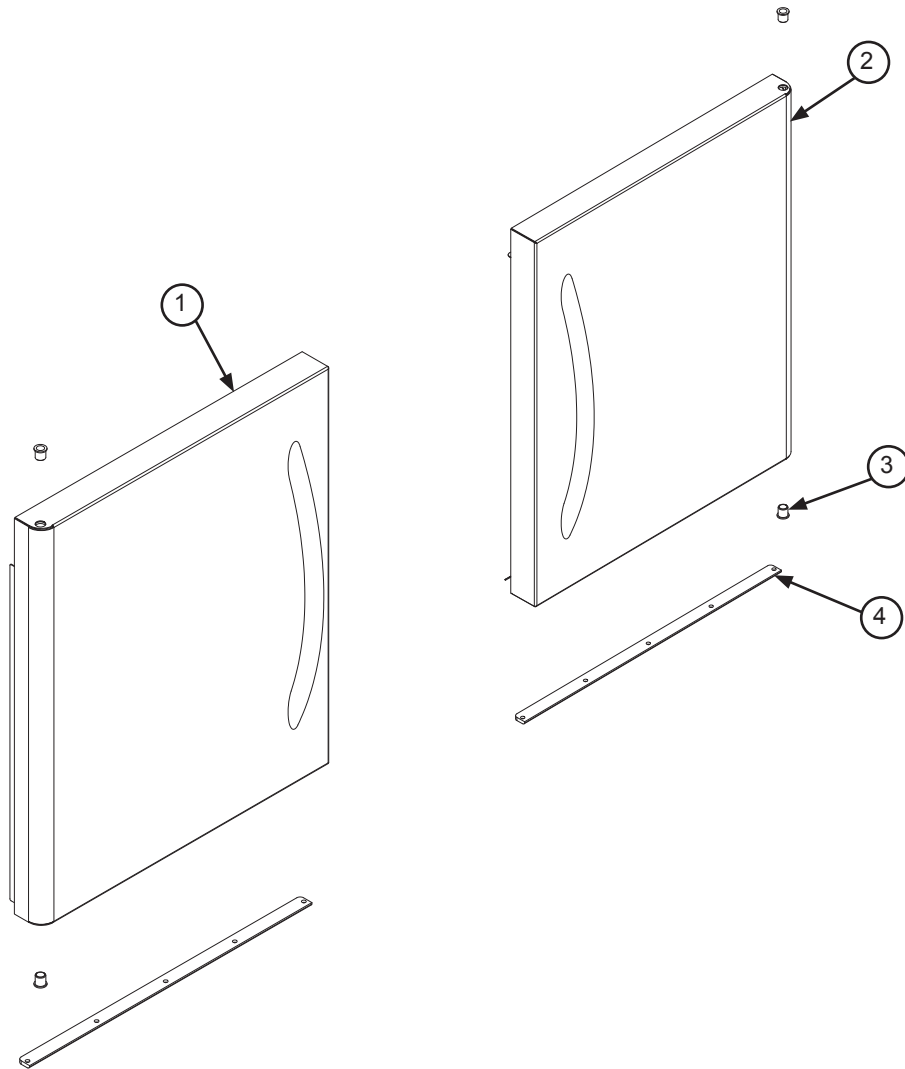

ITEM	QTY	DESCRIPTION	PART NUMBER
1	1	Left Door Assembly	04420-002-43-94
2	1	Right Door Assembly	05306-002-89-27
3	4	Bearing, Flanged Sleeve	03120-004-39-92
4	2	Door Seal	09330-004-17-41

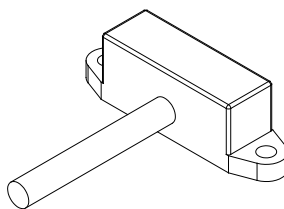

Door Switch  
05930-002-36-80

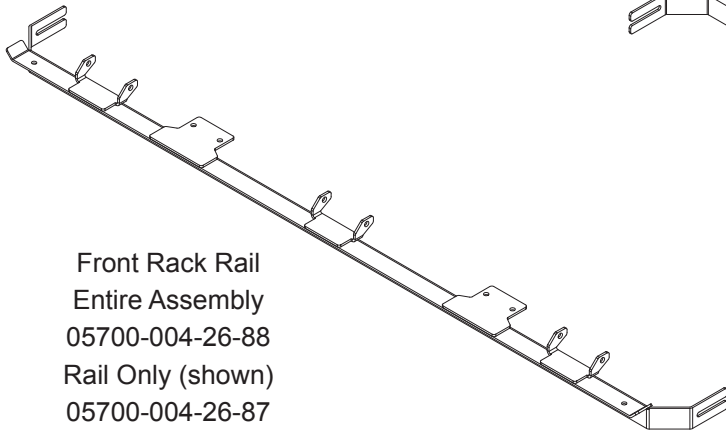

Front Rack Rail  
Entire Assembly  
05700-004-26-88  
Rail Only (shown)  
05700-004-26-87

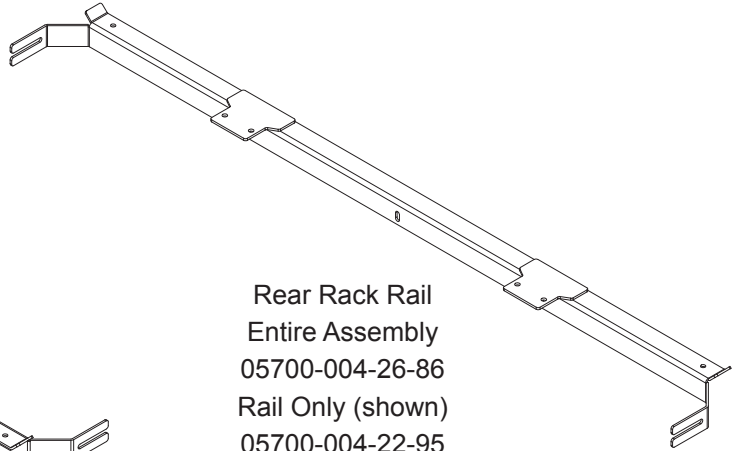

Rear Rack Rail  
Entire Assembly  
05700-004-26-86  
Rail Only (shown)  
05700-004-22-95

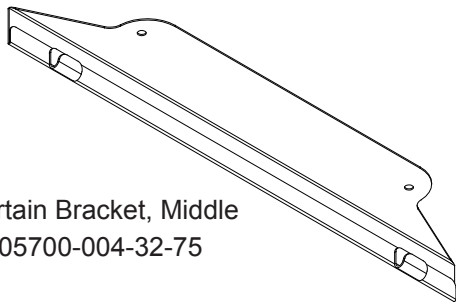

Curtain Bracket, Middle  
05700-004-32-75

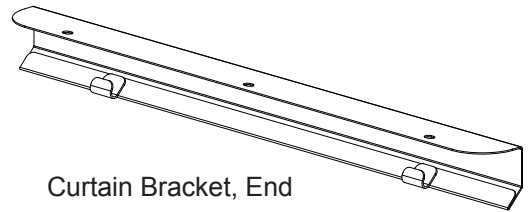

Curtain Bracket, End  
05700-004-21-24

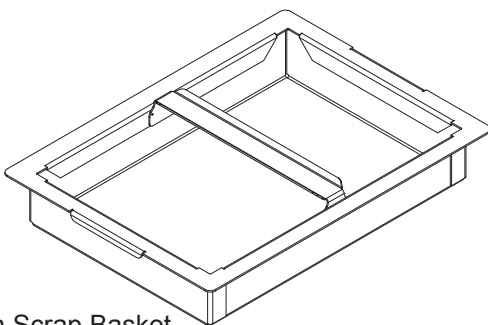

Pre-wash Scrap Basket  
05700-004-37-61

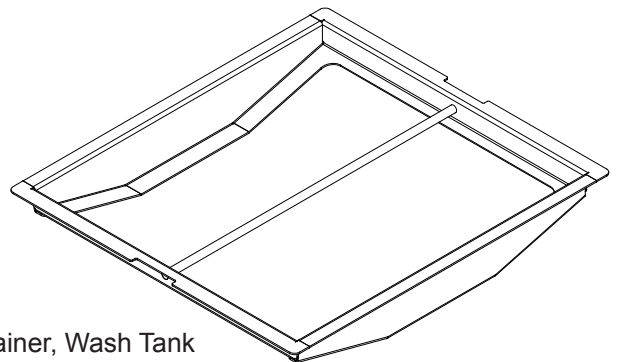

Strainer, Wash Tank  
05700-004-29-02

USE THIS SCHEMATIC FOR THE FOLLOWING BOOSTER HEATER OPTIONS:

- 208V, 60Hz, 3-Phase, 12 kW, 40° Rise
- 230V, 60Hz, 3-Phase, 12 kW, 40° Rise
- 460V, 60Hz, 3-Phase, 12 kW, 40° Rise
  
- 208V, 60Hz, 3-Phase, 18 kW, 70° Rise
- 230V, 60Hz, 3-Phase, 18 kW, 70° Rise
- 460V, 60Hz, 3-Phase, 18 kW, 70° Rise

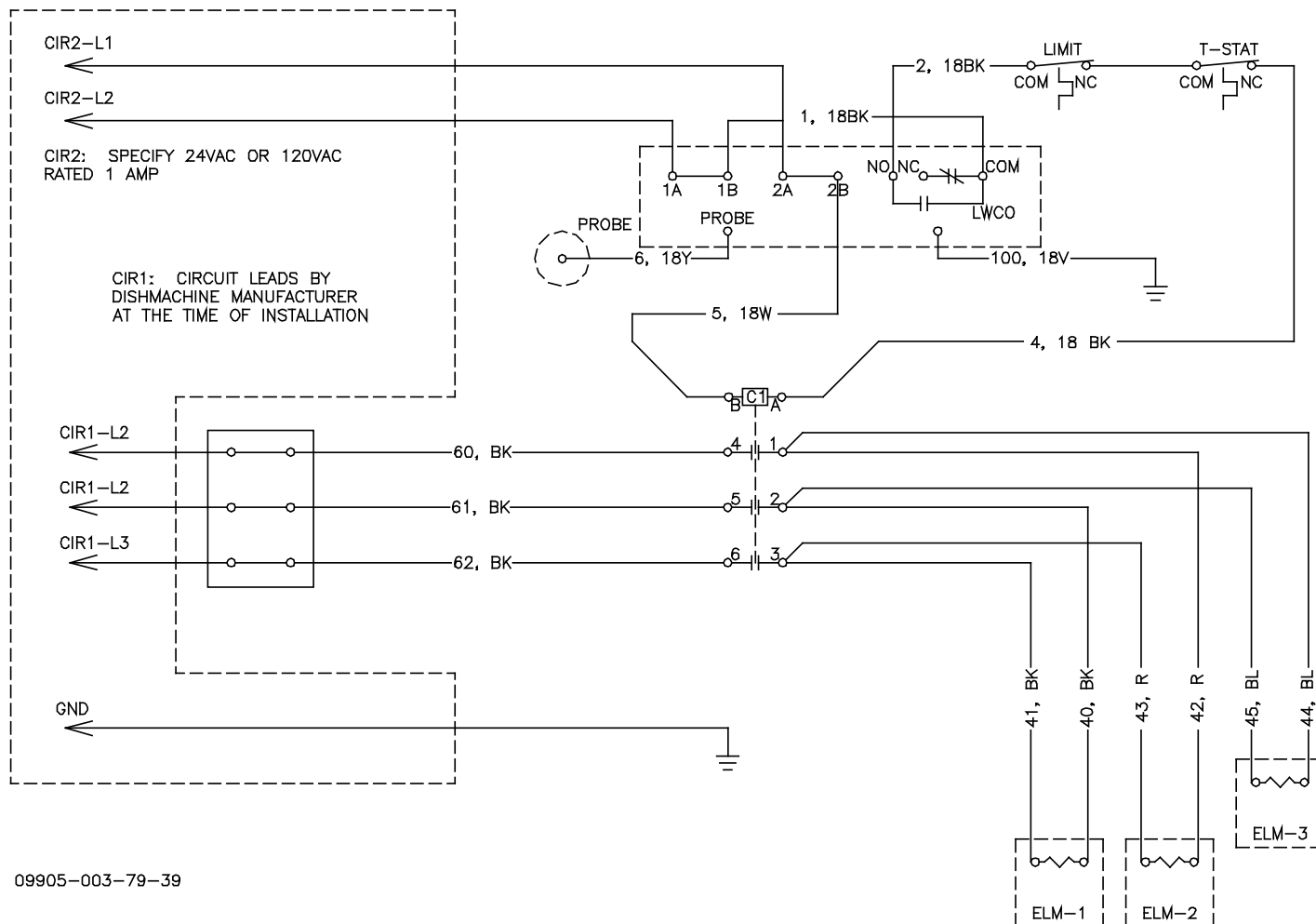

09905-003-79-39

USE THIS SCHEMATIC FOR THE FOLLOWING BOOSTER HEATER OPTIONS:

- 208V, 60Hz, 1-Phase, 12 kW, 40° Rise
- 230V, 60Hz, 1-Phase, 12 kW, 40° Rise

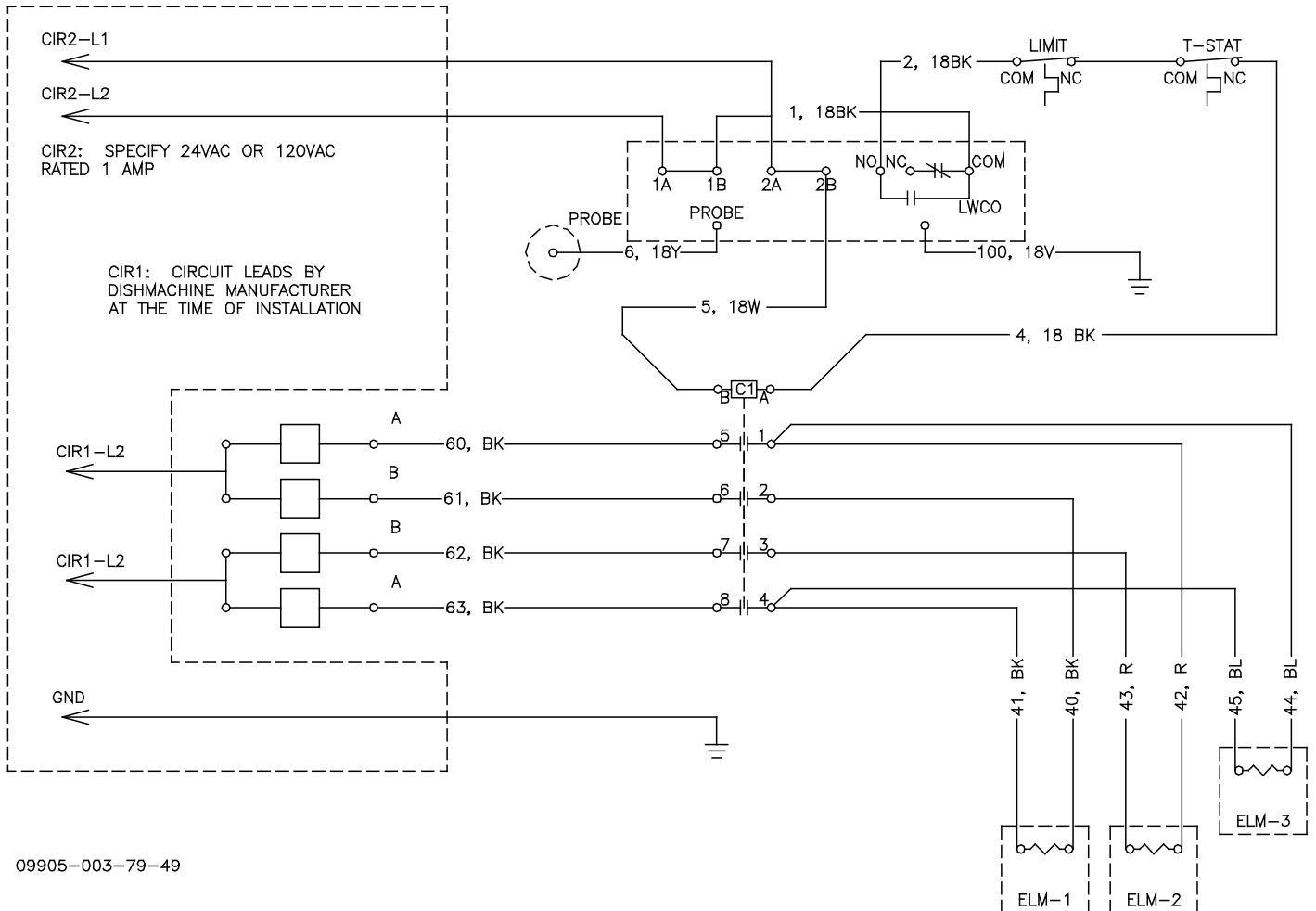

USE THIS SCHEMATIC FOR THE FOLLOWING BOOSTER HEATER OPTIONS:

- 208V, 60Hz, 1-Phase, 18 kW, 70° Rise
- 230V, 60Hz, 1-Phase, 18 kW, 70° Rise

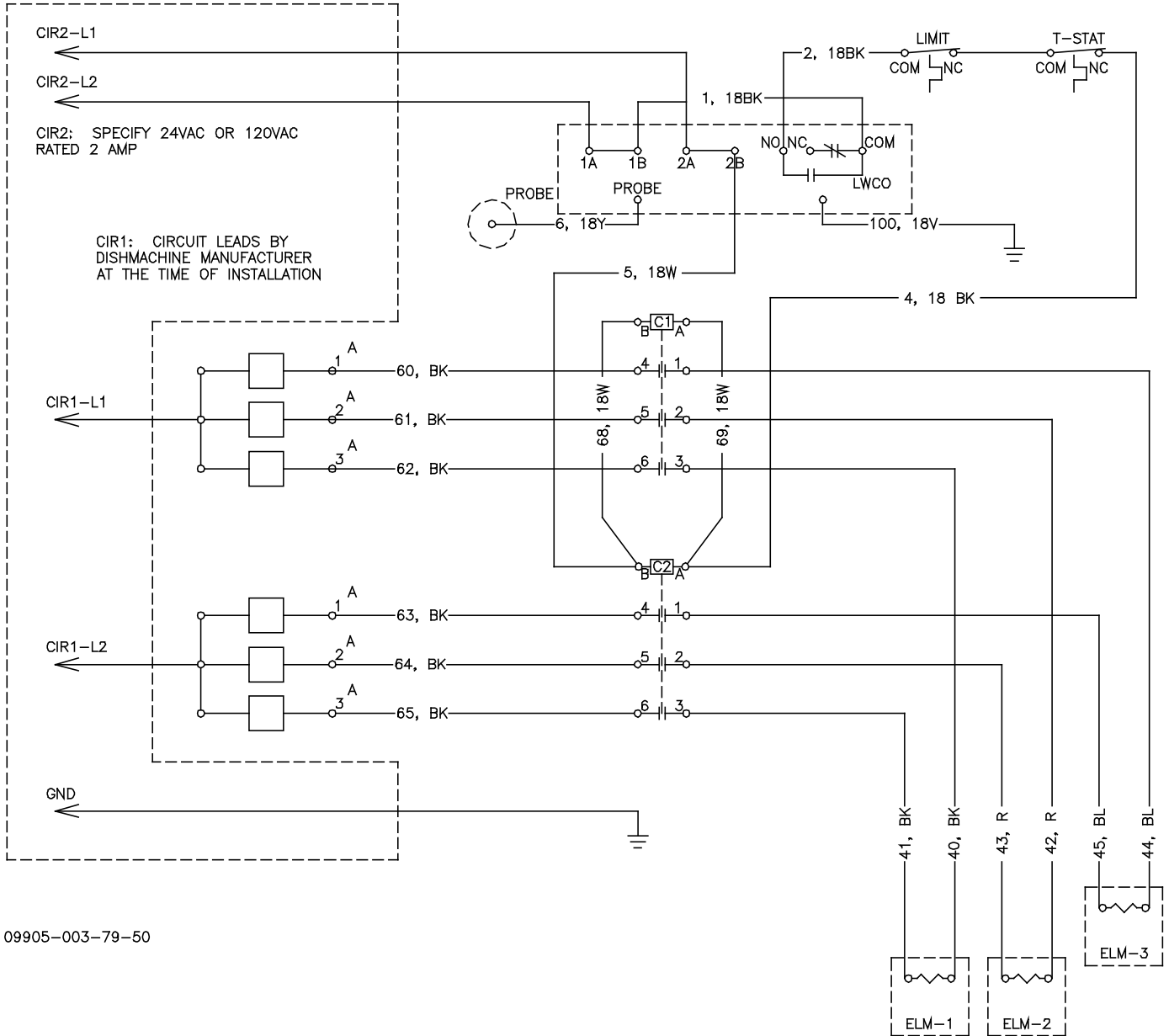



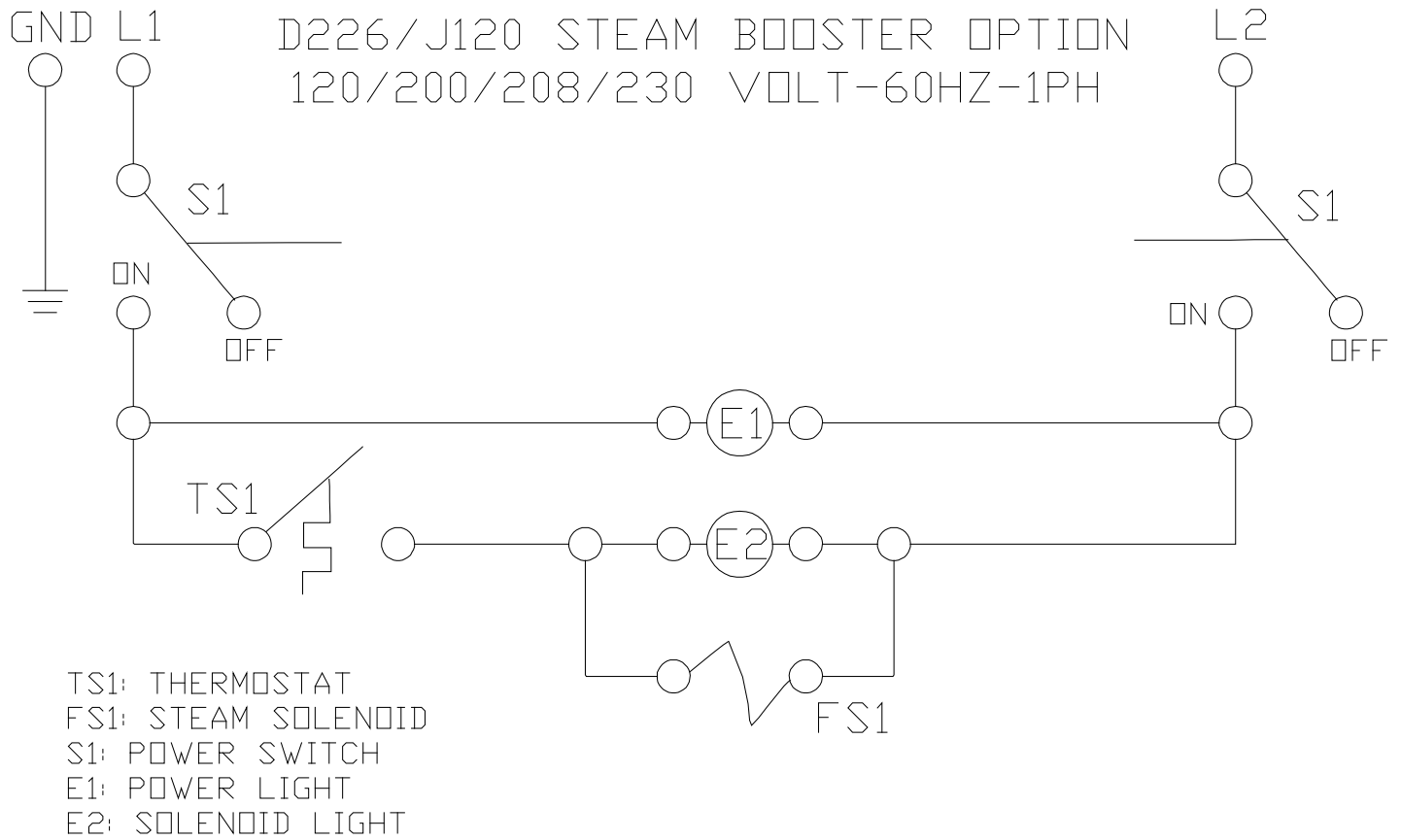

## RACKSTAR 44/66 SCHEMATIC

208/230 VOLTS, 50/60 Hz, 1-PHASE

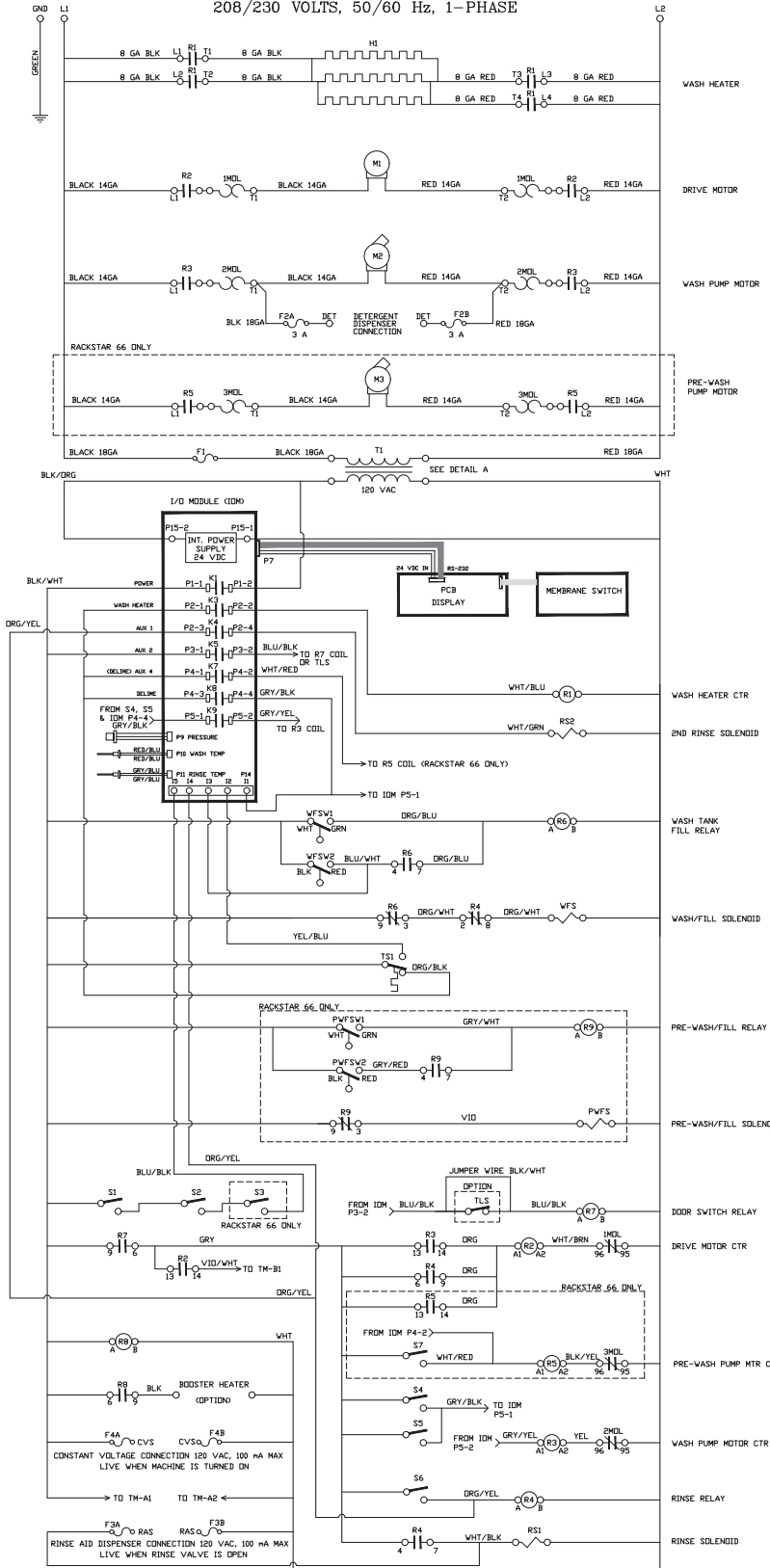

### LEGEND

- L1 L2 L3 POWER DISTRIBUTION BLOCK
- GND EARTH GROUND
- R1 WASH HEATER CONTACTOR
- R2 DRIVE MOTOR CONTACTOR
- R3 WASH PUMP MOTOR CONTACTOR
- R4 RINSE RELAY
- R5\* PRE-WASH PUMP MOTOR CONTACTOR
- R6 WASH TANK FILL RELAY
- R7 DOOR SWITCH RELAY
- R8 BOOSTER HEATER RELAY (OPTION)
- R9\* PRE-WASH/FILL RELAY
- H1 WASH HEATER
- M1 DRIVE MOTOR
- M2 WASH PUMP MOTOR
- M3\* PRE-WASH PUMP MOTOR
- IMDL DRIVE MOTOR OVERLOAD
- 2MDL WASH PUMP MOTOR
- 3MDL\* PRE-WASH PUMP MOTOR
- PWFSW1\* PRE-WASH FLOAT SWITCH 1 (UPPER)
- PWFSW2\* PRE-WASH FLOAT SWITCH 2 (LOWER)
- WFS1 WASH FLOAT SWITCH 1 (UPPER)
- WFS2 WASH FLOAT SWITCH 2 (LOWER)
- TLS TABLE LIMIT SWITCH (OPTION)
- TS1 HIGH-LIMIT THERMOSTAT
- CTF CONTROL TRANSFORMER
- F1 CONTROL FUSE
- F2 DETERGENT DISPENSER FUSE
- F3 RINSE AID DISPENSER FUSE
- F4 CONSTANT VOLTAGE CONNECTION FUSE
- CVS CONSTANT VOLTAGE SIGNAL
- DET DETERGENT DISPENSER CONNECTION
- RAS RINSE AID SIGNAL

\* DENOTES COMPONENTS SPECIFIC TO RACKSTAR 66

Connection Diagram for I/O Module PN 05945-004-36-34

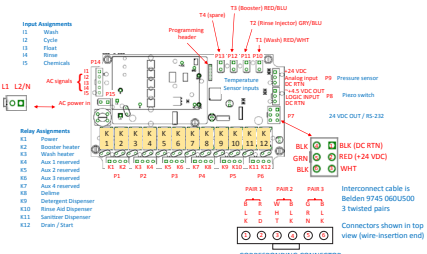

CONNECTING CONNECTOR TO DISPLAY PCB PN 05945-004-36-33

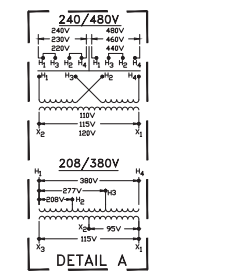

VOLTAGE SOURCE FOR EXTERNAL CONTACTOR 240VAC/24VDC MAX (CUSTOMER PROVIDES)

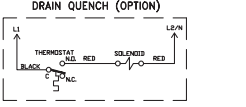
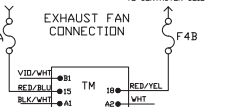

## RACKSTAR 44/66 SCHEMATIC

208/230 VOLTS, 50/60 Hz, 3-PHASE

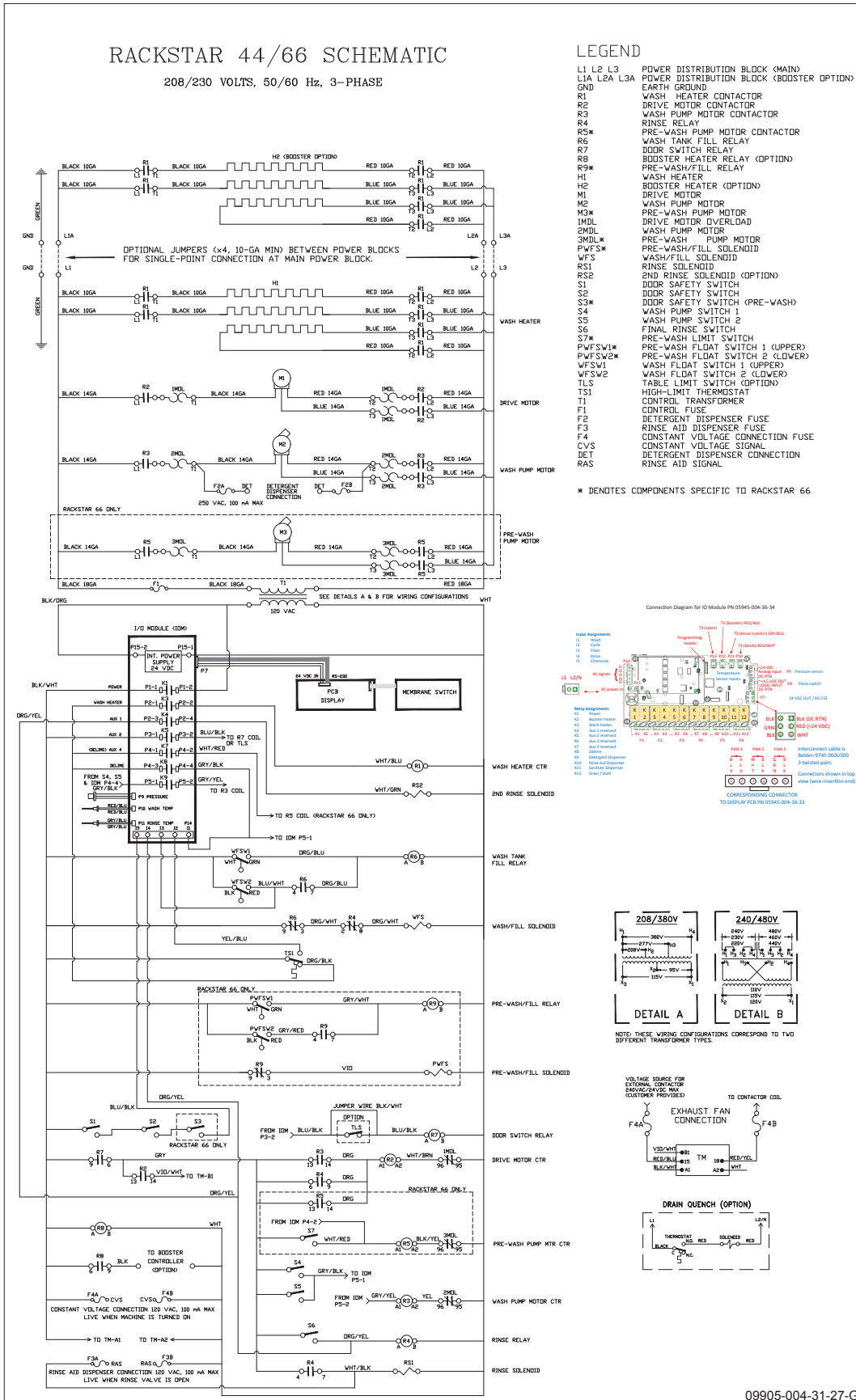

09905-004-31-27-G

## RACKSTAR 44/66 SCHEMATIC

380/480 VOLTS, 50/60 Hz, 3-PHASE

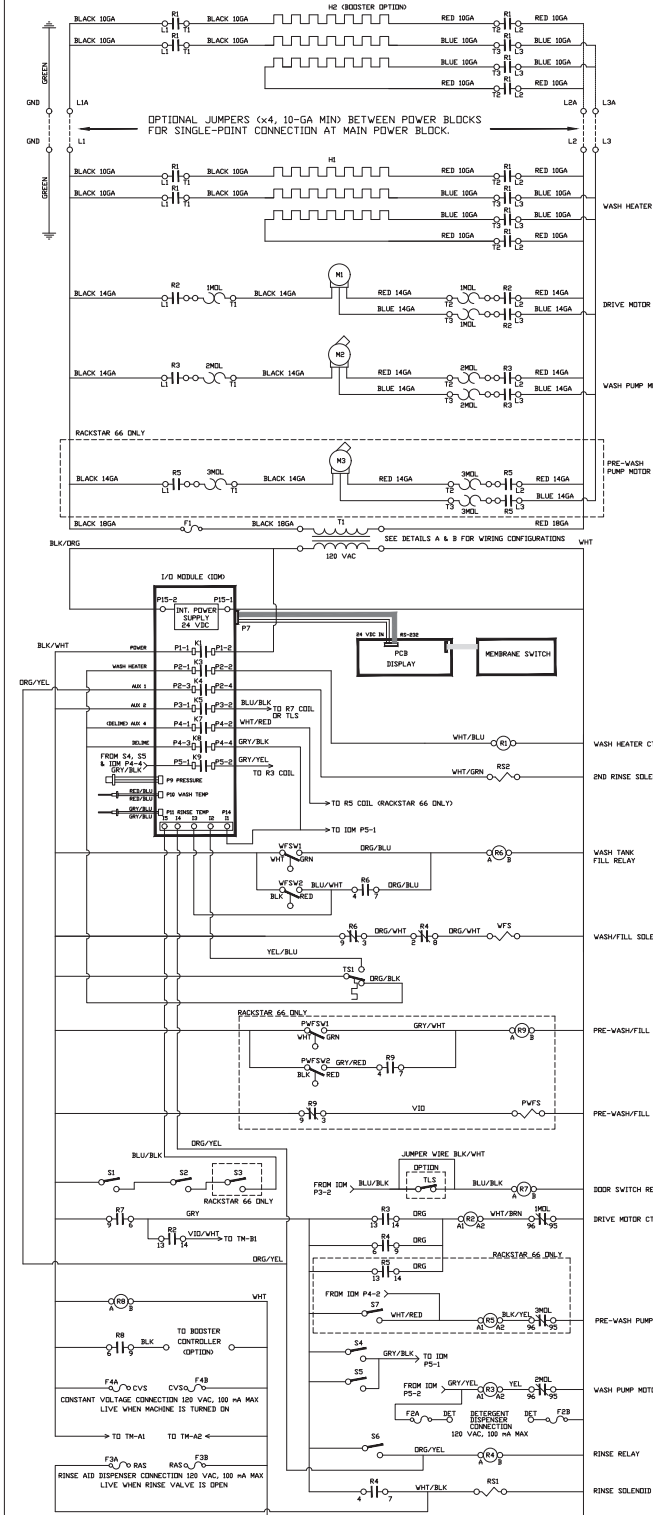

## LEGEND

- L1 L2 L3 POWER DISTRIBUTION BLOCK (MAIN)
- L1A L2A L3A POWER DISTRIBUTION BLOCK (BOOSTER OPTION)
- GND EARTH GROUND
- R1 WASH HEATER CONTACTOR
- R2 DRIVE MOTOR CONTACTOR
- R3 WASH PUMP MOTOR CONTACTOR
- R4 RINSE RELAY
- R5 PRE-WASH PUMP MOTOR CONTACTOR
- R6 WASH TANK FILL RELAY
- R7 DOOR SWITCH RELAY
- R8 BOOSTER HEATER RELAY (OPTION)
- R9M PRE-WASH/FILL RELAY
- H1 WASH HEATER
- H2 BOOSTER HEATER (OPTION)
- M1 DRIVE MOTOR
- M2 WASH PUMP MOTOR
- M3M PRE-WASH PUMP MOTOR
- M4 DRIVE MOTOR OVERLOAD
- M5M WASH PUMP MOTOR
- M6M PRE-WASH PUMP MOTOR
- PWF5M PRE-WASH/FILL SOLENOID
- WFS WASH/FILL SOLENOID
- RS1 RINSE SOLENOID
- RS2 2ND RINSE SOLENOID (OPTION)
- S1 DOOR SAFETY SWITCH
- S2 DOOR SAFETY SWITCH
- S3M DOOR SAFETY SWITCH (PRE-WASH)
- S4 WASH PUMP SWITCH 1
- S5 WASH PUMP SWITCH 2
- S6 FINAL RINSE SWITCH
- S7M PRE-WASH LIMIT SWITCH
- PWF5W1M PRE-WASH FLDAT SWITCH 1 (UPPER)
- PWF5W2M PRE-WASH FLDAT SWITCH 2 (LOWER)
- WFSW1 WASH FLDAT SWITCH 1 (UPPER)
- WFSW2 WASH FLDAT SWITCH 2 (LOWER)
- TLS TABLE LIMIT SWITCH (OPTION)
- TSM HIGH-LIMIT THERMISTAT
- T1 CONTROL TRANSFORMER
- F1 CONTROL FUSE
- F2 DETERGENT DISPENSER FUSE
- F3 RINSE AID DISPENSER FUSE
- F4 CONSTANT VOLTAGE CONNECTION FUSE
- CVS CONSTANT VOLTAGE SIGNAL
- DET DETERGENT DISPENSER CONNECTION
- RAS RINSE AID SIGNAL

M DENOTES COMPONENTS SPECIFIC TO RACKSTAR 66

Connection Diagram for ID Module PN 02945-004-36-34

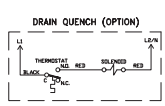
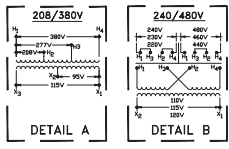
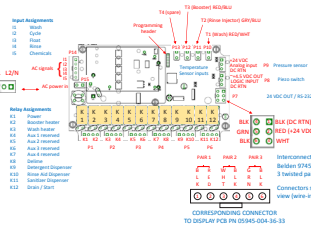

09905-004-38-57-A

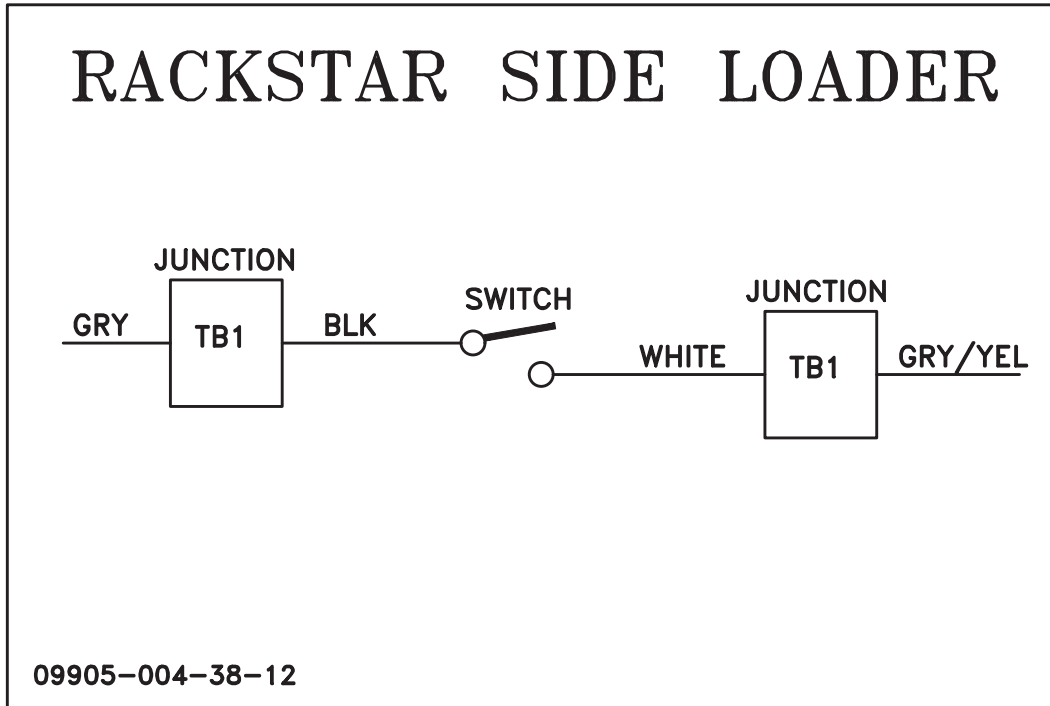

This page can be copied and the display templates cut-out. Lay the cut-out over the display and use the Up-arrow, Down-arrow, and Select Buttons to locate the hidden programming buttons.

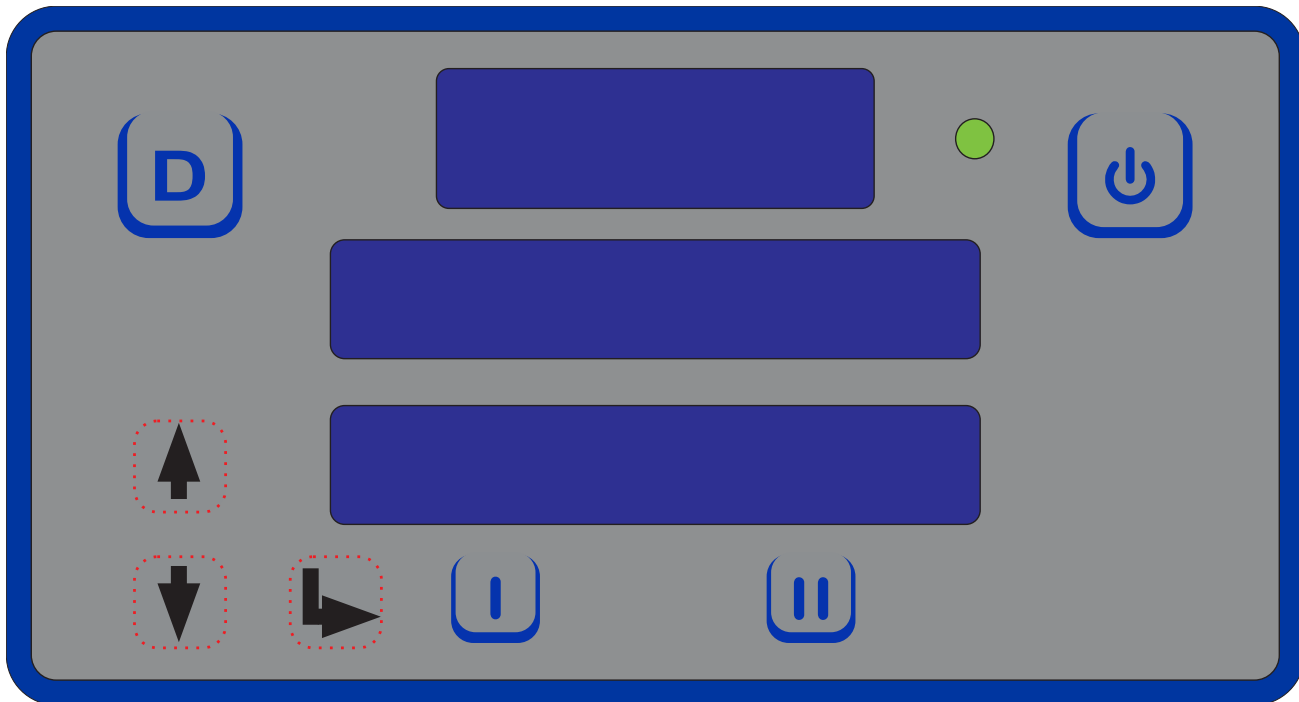
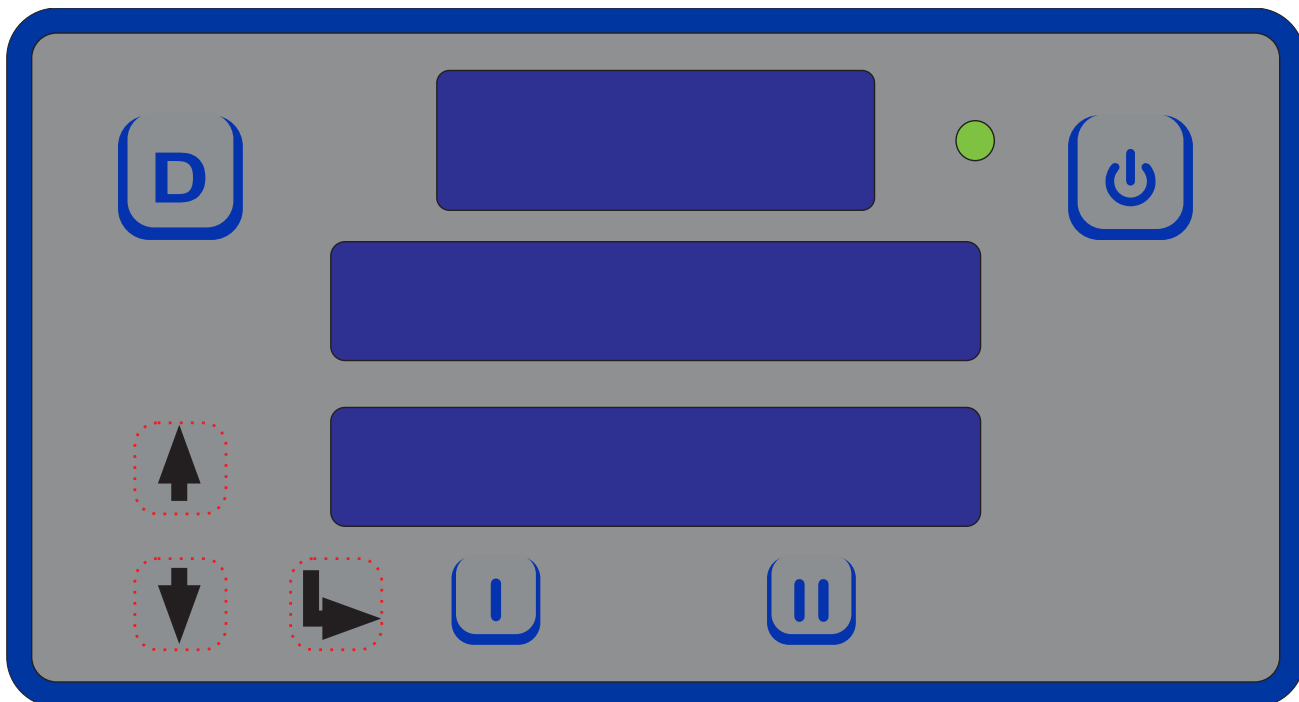





Jackson WWS, Inc. • 6209 N. US Hwy 25E • Gray, KY 40734 USA  
1.888.800.5672 • [www.jacksonwws.com](http://www.jacksonwws.com)