



VECTAIRE™ Single Deck, Full-Size, Bakery Depth Gas Convection Oven

Item No. _____

Project _____

Quantity _____

SL70 & SL115 Series



Model SL70-AP shown

SHORT/BID SPECIFICATION

Convection oven shall be a Montague *Vectaire* Model
[Specify one]:

- SL70** with 70,000 BTU/hr output
- SL115** with 115,000 BTU/hr output

[Specify one]:

- AH**, with Cook-n-Hold Controls including: solid state 150-500°F (66-260°C) thermostat with RTD platinum temperature sensor, 24-hour digital countdown timer with alarm, programmable HOLD feature and burner-ON indicator light
- AP**, with five-button programmable menu pad, plus all Cook-n-Hold Controls including: solid state 150-500°F (66-260°C) thermostat with RTD platinum temperature sensor, 24-hour digital countdown timer with alarm, programmable HOLD feature and burner-ON indicator light

...with electronic ignition; a porcelainized steel oven interior with two speed fan, nine rack positions, five bright nickel racks with rack stops and no-tip guides standard; ball bearing mounted 50-50 split doors with double pane viewing windows; 24" (610mm) painted steel gusseted legs and all the features listed and options/accessories checked:

OVEN INTERIOR CONSTRUCTION:

- Porcelainized 16-gauge steel interior
- 27" (686mm)(Bakery Depth) interior accepts pans lengthwise or sideways
- Nine-position bright nickel rack guides

MODEL-PAN/RACK GUIDE:

✓ Model No.	Racks/ Positions	Pan Loading*		Rack Spacing	
		Length	Sideways	5-racks	9-racks
SL70-AH	5/9	yes	yes	3-3/8" (86mm)	1-1/2" (38mm)
SL70-AP	5/9	yes	yes	3-3/8" (86mm)	1-1/2" (38mm)
SL115-AH	5/9	yes	yes	3-3/8" (86mm)	1-1/2" (38mm)
SL115-AP	5/9	yes	yes	3-3/8" (86mm)	1-1/2" (38mm)

*18" x 26" (457 x 660mm) sheet pans length or sideways

- Five bright nickel pan racks, with rack-stop and no-tip guides standard
- 4" (102mm) of insulation compressed to 2" (51mm) with metal sheathing
- Two covered interior lights

BURNERS & BLOWER SYSTEMS:

- Indirect-heated "muffled oven" design
- Stainless steel and cast iron burner
- Removable stainless steel burner baffle
- Burner pilot with dependable electronic ignition
- Blower with 3/4-horsepower two-speed motor

EXTERIOR CONSTRUCTION FEATURES:

- Satin finish stainless steel front, sides and top
- Aluminized steel back and flue deflector with stainless front-trim
- Ball bearing mounted 50-50 split double doors
- Double pane thermal viewing windows
- Single vertical grab handle opens both doors
- 24" (610mm) black painted-steel gusset-type legs, with adjustable bullet feet
- 6' power cord with grounded NEMA 5-15P plug

CONTROL FEATURES:

- Power/Fan speed control (two speed fan)
- Automatic fan cutoff when door is opened (except in cool-down)
- Momentary-ON interior light switch
- Burner-ON indicator light
- Cook-n-Hold -AH Package:**
 - Solid state 150-500°F (66-260°C) thermostat
 - Programmable 140-200°F (60-93°C) HOLD feature
 - Precise RTD platinum temperature probe
 - 24-hour digital countdown timer with alarm
 - Intermittent Fan Operation (IFO)
- Programmable-AP Package:**
 - Five button programmable menu pad
 - Solid state 150-500°F (66-260°C) thermostat
 - Programmable 140-200°F (60-93°C) HOLD feature
 - Precise RTD platinum temperature probe
 - 24-hour digital countdown timer with alarm
 - Intermittent Fan Operation (IFO)

AGENCY APPROVALS

- NSF Listed



VC0-7 [Rev.2/17]

VECTAIRE™ Single Deck, Full-Size, Bakery Depth Gas Convection Oven

Item No. _____

Project _____

Quantity _____

SL70 & SL115 Series

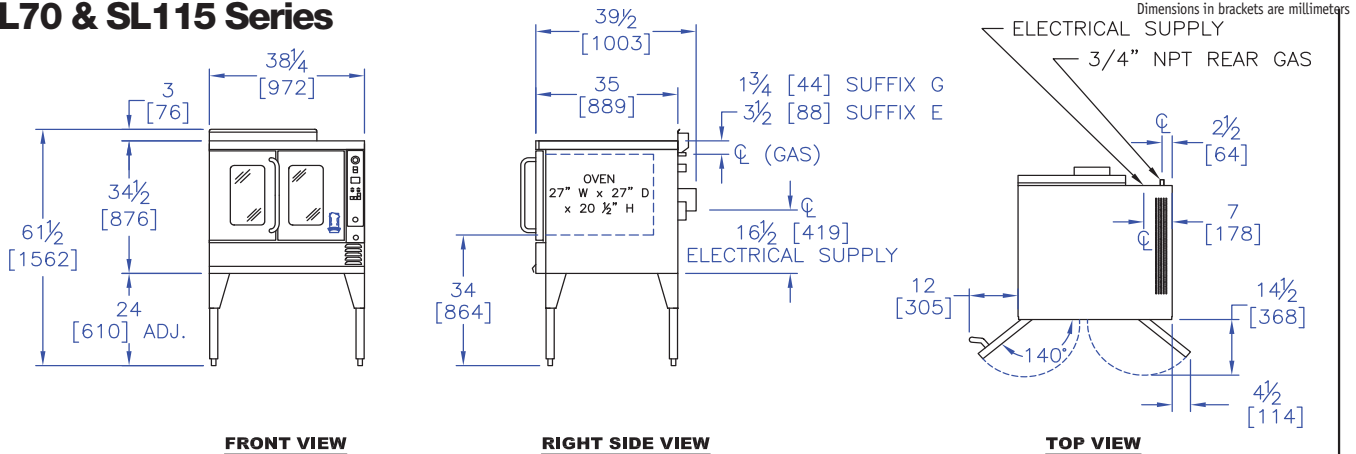

OPTIONS GUIDE:

Installation Alternatives:

- Stacking Kit (for bottom unit)
- Flexible Gas Quick-Disconnect Kit [with restraint]
- Stainless steel downdraft diverter
- Stem casters for gusset-style legs; set of 4 ea., 5" (127mm)
- Modular Stand (open base) with 4" (102mm) frame, stainless steel front, lower shelf and 26" (660mm) stainless steel legs, plus:
 - Stem Casters 3-1/2" (89mm)
 - Side and back to match oven
 - 9-position removable pan slides for stand
 - Heat Shield Kit [See minimum clearances]

Electric, Controls & Motor Alternatives:

- 120-volt, 1-Phase, 60 Hz, 11.4 AMP [w/6' (1.8 m) cord]
- 208-240-Volt, 1-Phase, 60 HZ, 5.7 AMP
- For 208-240-Volt, 3-phase [Consult Factory]
- Electronic Ignition- **IE** suffix [vertical doors only]

Racks & Security:

- Stainless steel drip tray
- Extra Racks: ____ ea. std. ____ ea. heavy duty
- 11-position rack guides
- Solid Doors [in place of windows]
- Security Options [Consult Factory]

Finish:

- Full stainless steel oven interior [-ASC suffix]
- Stainless steel back panel
- Stainless steel flue deflector
- Stainless steel gusset-type legs
- Stainless steel exterior bottom
- Stainless steel louvered back panel

INSTALLATION REQUIREMENTS & SHIPPING INFORMATION

- Ovens must be installed in accordance with local codes or in their absence with the National Fuel Gas Code: ANSI Z223.1; CAN/CGA-B149.1 Natural Fuel and Propane Installation Code, as applicable. Compliance with codes is the responsibility of the Owner and Installer.
- An adequate ventilation system is required. Refer to National Fire Protection Association Standard No. 96, Standard for Ventilation Control and Fire Protection of Commercial Cooking Operations
- This appliance is intended for commercial use by professionally trained personnel. NOT intended for Residential Use.
- Specify installation elevation:** _____ if above 2000 feet (610m).
- GAS INLET SIZE (All Models):** One ¾" NPT gas connections provided at left-rear. One ¾" NPT gas pressure regulators are provided and must be installed (by others) when unit is connected to gas supply.
- The incoming gas line pressure into the regulator should be 8"-14" w.c. for natural gas, and 12"-14" w.c. for propane gas.

Minimum Clearances	Combustible Construction	Noncombustible Construction
From Back Wall	6" (152mm)	5" (127mm)
Left & Right Side*	6" (152mm)	0"
With 24" (610mm) legs	Suitable for installation on combustible floors	

*SL Vectaire spacing to adjacent equipment: 6" (152mm) minimum clearance on right side between similar ovens or other cooking equipment. Optional heat shield kits are available to reduce the clearance between similar ovens to 1" (25mm) and between other equipment to 2" (51mm). Consult factory.

Models:	Burners	Specify Type of Gas:		Shipping Weight	Shipping Class	Cube (Crated) ft ³ /m ³
		<input type="checkbox"/> Natural	<input type="checkbox"/> Propane			
Gas Delivery Pressure:		3.5" WC				
		BTU/hr (kW)	BTU/hr (kW)			
SL70-AH	1	70,000 (20.5)	70,000 (20.5)	515 lbs (233 kg)	70	34/.9
SL70-AP	1	70,000 (20.5)	70,000 (20.5)	515 lbs (233 kg)	70	34/.9
SL115-AH	1	115,000 (33.7)	90,000 (26.4)	515 lbs (233 kg)	70	34/.9
SL115-AP	1	115,000 (33.7)	90,000 (26.4)	515 lbs (233 kg)	70	34/.9
With Modular Stand add:				78 lbs (35 kg)	70	21/.6
Entry Clearance: 34-3/4" (883mm) uncrated						

Due to continuous product improvements, specifications are subject to change without notice.



THE MONTAGUE COMPANY
 1830 Stearman Avenue, Hayward, CA 94545
 800 345-1830 • Fax: 510 785-3342
 www.montaguecompany.com

