

Cleveland

POWERPAN™ SERIES

ELECTRIC, 35" RIM HEIGHT,,
30 & 40 GALLON (110 & 150 LITER)

Project _____
 Item _____
 Quantity _____
 FCSI Section 11400 _____
 Approved _____
 Date _____

Braising Pans / Tilting Skillets

Models

- SEL-30-T1 • SEL-40-T1



Shown with
Standard
Controls



easyDial and
Core Temperature
Probe options

Standard Features

- Open base design for easy cleaning and maintenance.
- 5/8" Stainless Steel Bead Blasted cooking surface prevents warping and keeps food from sticking.
- Durable 12 gauge, 304 Stainless Steel pan construction. 5/8" (16mm) mild steel clad bottom plus a 1/16" (1.6mm) Stainless Steel plate for even temperature distribution.
- Low 35" rim height for easy operation and cleaning.
- Splash Proof Controls and construction.
- Easy-to-turn manual hand tilt with enclosed permanently lubricated gearbox. Optional power tilt with manual override available.
- Gallon/Liter Markings and Vented Spring Assist Cover standard.
- Available with Optional 2" Tangent Draw-Off Valve.
- 10° Cooking Feature. Tilt unit up to 10° without the power being turned off.
- Adjustable, Electronic Thermostat accurately controls temperature from 100° to 450° F.
- Standard Voltages 208-240, single and three phase.
- Spring-Assist Cover with full width handle and vent.
- Typical approvals include UL, CSA, CE and NSF.
- Adjustable Solid State Thermostat accurately controls temperature from 140°F to 425°F.

Standard Control Panel includes:

Temperature Control Dial, LED ON Indicator Light, Main Power Switch.

easyDial Control Panel (optional) includes:

Selector Dial with LED Ring, Large Display Screen, Three Cooking Modes, Built-In Self-Diagnostics and Display, Temperature Select Button, Timer Set Button (Hrs/Min), Settings Button, Main Power Button, Probe Connection Port, LED Indicator Lights for Heat-ON, Product Probe, Temperature, Time, Settings, Self-Diagnostics.

Options & Accessories

- easyDial Control
- Core Temperature Probe Option
- Power Tilt with Manual Override (PT2)
- 2" (50 mm) Tangent Draw-Off Valve (TD2SK), left side only
- Double or Single Pantry Faucet (SPS14, DPS14), includes Faucet Mounting Bracket
- Faucet Bracket (FBKT1)
- Pan Carriers (PCS), not available on 30 gallon models with a Tangent Draw-Off Valve • Vegetable Steamer Baskets (VS)
- Hot & Cold Water Pre-Rinse Spray Head with Hose (PRS-S)
- Poaching Pans (PP)
- Protective Control Cover (CP-PCB-T1)
- Casters, 2 swivel, 2 locking (CST1)
- High Wattage Option (HW) (required for CE) 16KW on 30 gallons, 24KW on 40 gallons
- Voltage Options:
 - VOSK1, 240 Volt, 60 Hz, 3 Phase
 - VOSK2, 380/415 Volt, 50 Hz, 3 Phase - for export
 - VOSK3, 440/480 Volt, 60 Hz, 3 Phase

Short Form Specifications

Shall be CLEVELAND, Tilting Skillet Model Number SEL-____-T1, electric (____ KW, ____ Volts) holding no less than ____ gallons (____ liters); Complete with Thermostatic and Safety Controls, Gallon/Liter Markings, 5/8" Stainless Steel Clad Cooking Surface with Bead Blasted Finish, Easy to use Manual Hand Tilt with Enclosed Permanently Lubricated Gearbox, Spring Assist Cover with adjustable Vent, Adjustable Feet with Rear Flanged and Front Bullet Style, Gallon/Liter Markings and Splash Proof Controls.

KE004046-88

Cleveland

DIMENSIONS

MODEL	A	B	C	D	F	G	H	CLEARANCE
SEL-30-T1	37 7/8"	24 1/2"	31 3/4"	12"	18 1/4"	5 3/4"	8"	RIGHT: 4" (102mm) (manual tilt) 1" (26mm) (power tilt)
	(963mm)	(623mm)	(807mm)	(305mm)	(464mm)	(146mm)	(204mm)	
SEL-40-T1	49 7/8"	36 1/2"	43 3/4"	18"	24 1/4"	5 3/4"	8"	LEFT: 0" REAR: 0"
	(1267mm)	(928mm)	(1112mm)	(458mm)	(616mm)	(146mm)	(204mm)	

ELECTRICAL

Volts	Ph	Hz	Total Watts	Amps	Wire Size	Volts	Ph	Hz	Total Watts	Amps	Wire Size
SEL-30-T1 (Standard Wattage)						SEL-40-T1 (Standard Wattage)					
208	1	60	12000	57.7	4	208	1	60	18000	86.5	2
208	3	60	12000	33.3	8	208	3	60	18000	50.0	6
240	1	60	12000	50.0	6	240	1	60	18000	75.0	3
240	3	60	12000	28.9	8	240	3	60	18000	43.3	6
380	1	50	10013	26.3	8	380	1	50	15019	39.5	6
380	3	50	10013	15.2	12	380	3	50	15019	22.8	10
416	1	50	12000	28.8	8	416	1	50	18000	43.3	6
416	3	50	12000	16.7	10	416	3	50	18000	25.0	8
480	1	60	12000	25.0	8	480	1	60	18000	37.5	6
480	3	60	12000	14.4	12	480	3	60	18000	21.7	10
SEL-30-T1 (High Wattage)						SEL-40-T1 (High Wattage)					
208	1	60	16020	77.0	3	208	3	60	24000	66.6	4
208	3	60	16020	44.5	6	240	3	60	24000	57.7	4
240	1	60	16020	66.8	4	380	3	50	20026	30.4	8
240	3	60	16020	38.5	6	416	3	50	24000	33.3	8
380	1	50	13367	35.2	8	480	3	60	24000	28.9	8
380	3	50	13367	20.3	10						
416	1	50	16020	38.5	6						
416	3	50	16020	22.2	10						
480	1	60	16020	33.4	8						
480	3	60	16020	19.3	10						

CAPACITIES

In 4 oz. servings. Other sizes may be calculated.
 30 gallons / 115 Liters.....960
 40 gallons / 150 Liters.....1280



Standard Control Panel



easyDial Control Panel with Core Temperature Probe

LEG LOCATION & SUGGESTED FLOOR DRAIN DETAIL

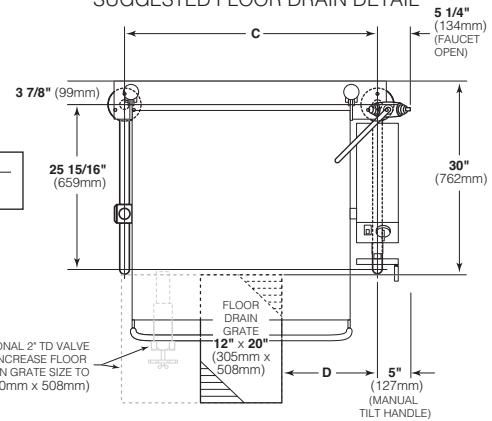

WATER

(C) COLD WATER (H) HOT WATER
 PIPING - 1/2" NPT (DOUBLE)
 3/8" COPPER TUBE (SINGLE)

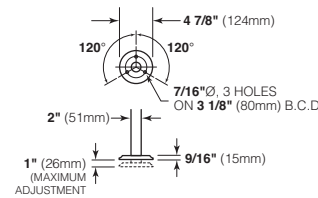
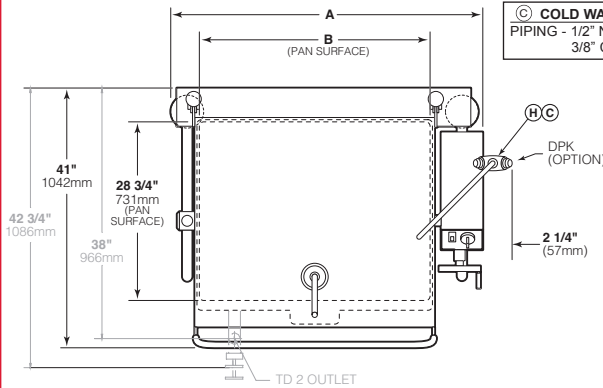

FLANGED FOOT DETAIL (REAR LEGS ONLY)

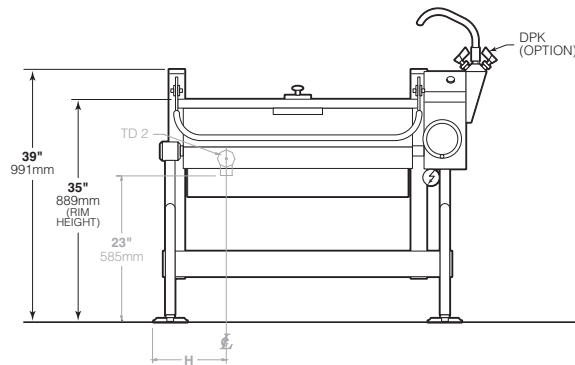

NOTE: OPTIONAL 2" TD VALVE SHOWN IN GRAY

NOTES:

Cleveland Range reserves right of design improvement or modification, as warranted.
 Many regional, state and local codes exist and it is the responsibility of the owner and installer to comply with the codes.
 Cleveland Range equipment is built to comply with applicable standards for manufacturers. Included among those approval agencies are U.L., NSF, CGA, CSA, ETL and others.

(NOT TO SCALE)

Braising Pans / Tilting Skillets

760 Beta Drive, Unit D
 Mayfield Village, Ohio 44143

Tel 1.216.481.4900
 Fax 1.216.481.3782
 Email steam@clevelandrange.com

www.clevelandrange.com
 Section 9, Page 12
 10 / 2023

Timeless Quality, Trusted For Life®