



PRODUCT SPECIFICATIONS SHEETS ICE MERCHANDISERS - OUTDOOR



ICB-1-SLANT

Height . . . 74.00"
Length . . . 47.75"
Depth . . . 34.25"



ICB-1

Height . . . 75.75"
Length . . . 55.50"
Depth . . . 36.25"



ICB-2

Height . . . 75.75"
Length . . . 76.25"
Depth . . . 36.25"



ICB-2-SLANT

Height . . . 74.00"
Length . . . 76.00"
Depth . . . 34.25"

FEATURES

- Exterior cabinet made of white or black vinyl clad steel
- Custom front trim enhances cabinet appearance
- Hinged door with chrome plated hardware seals magnetically
- Reinforced 16 gauge galvanized steel base
- Foamed in place high density CFC free polyurethane foam insulation
- Heavy duty galvanized steel interior with air distribution channels
- High capacity blower cooled refrigeration system with automatic defrost



ICB-2-L (FORMALLY ICB-100)

Height . . . 75.75"
Length . . . 96.00"
Depth . . . 36.25"

MODEL NO. NUMBER	DESCRIPTION	VOLTAGE	AMPS	TEMP	HP	EST. SHIP WEIGHT
ICB-1-SLANT	1 DOORS/SOLID	115	10.0	23° F - 30° F	1/3	494#
ICB-1-	1 DOORS/SOLID	115	10.0	23° F - 30° F	1/3	494#
ICB-2	2 DOORS/SOLID	115	12.0	23° F - 30° F	1/2	658#
ICB-2-SLANT	2 DOORS/SOLID	115	12.0	23° F - 30° F	1/2	635#
ICB-2-L	2 DOORS/SOLID	115	12.0	23° F - 30° F	1/2	774#

- Cases are designed to operate at 75°F and 55% relative humidity.
- Specification subject to change without notice.



A Division of HMC Enterprises LLC • 831 East Cayuga St • Philadelphia, PA 19124 USA

(215) 464-6800 • 1-800-344-8222 • Fax (215) 969-4890 • E-Mail: sales@fogelusa.com • www.fogelusa.com

TECHNICAL DATA / ICE MERCHANDISERS - OUTDOOR

MODEL #	ICB-1	ICB-2	ICB-2-L	ICB-1-SLANT	ICB-2-SLANT
OUTSIDE DIMENSIONS					
DEPTH	36.25"	36.25"	36.25"	34.25"	34.25"
LENGTH	55.45"	76.00"	96.00"	47.75"	76.00"
HEIGHT	75.75"	75.75"	75.75"	74.00"	74.00"
DOOR SIZE					
DOOR TYPE	1 SWING	2 SWING	2 SWING	1 SWING	2 SWING
INSIDE DIMENSIONS					
DEPTH	30.00"	30.00"	30.00"	29.75"	29.75"
LENGTH	51.00"	72.00"	92.00"	48.9"	92.00"
HEIGHT	55.50"	55.50"	55.50"	54.00"	54.00"
# OF 7LB BAGS	150	225	300	125	250
CAPACITY: CUBIC FOOT	47	60	85	40	85
SPECIFICATIONS					
OPERATING TEMPERATURE	23°F-30°F	23°F-30°F	23°F-30°F	23°F-30°F	23°F-30°F
COMPRESSOR SIZE HP	1/3	1/2	1/2	1/3	1/2
DEFROST	3@30MIN	3@30MIN	3@30MIN	3@30MIN	3@30MIN
VOLTAGE	115	115	115	115	115
AMPERAGE	10.0	12.0	12.0	10.0	12.0
CORD AND PLUG	YES	YES	YES	YES	YES
SHIPPING DIMENSIONS					
DEPTH	41.00"	41.00"	41.00"	41.00"	41.00"
LENGTH	60.00"	81"	101"	54"	101"
HEIGHT	82.00"	82.00"	82.00"	80"	80"
GROSS WEIGHT LBS.	494	658	774	494	774
CUBIC FEET	116	157	196	105	196

**SIDE VIEW
ICB-1-SLANT**

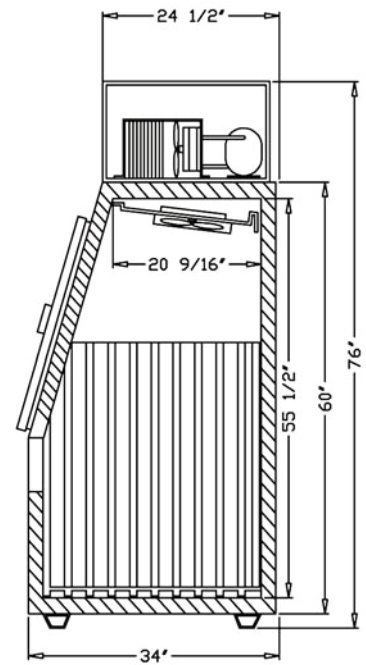

TOP VIEWS

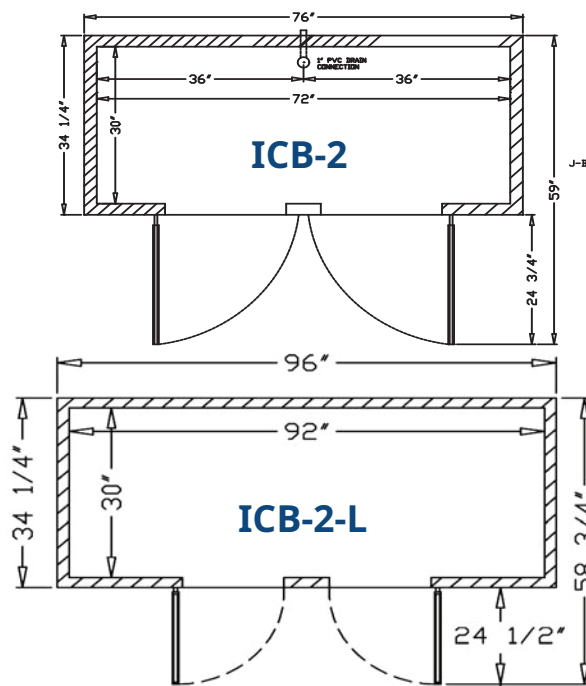
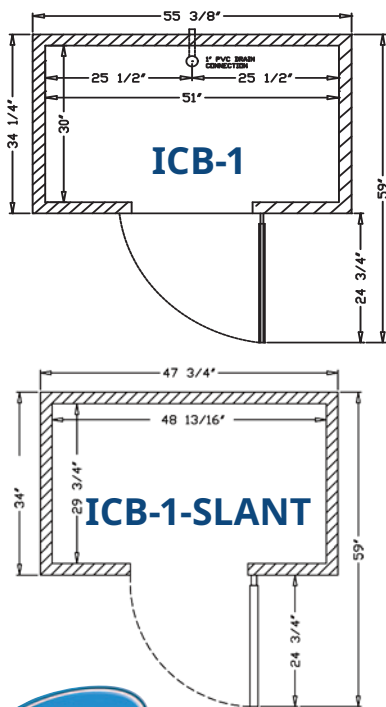

SIDE VIEW

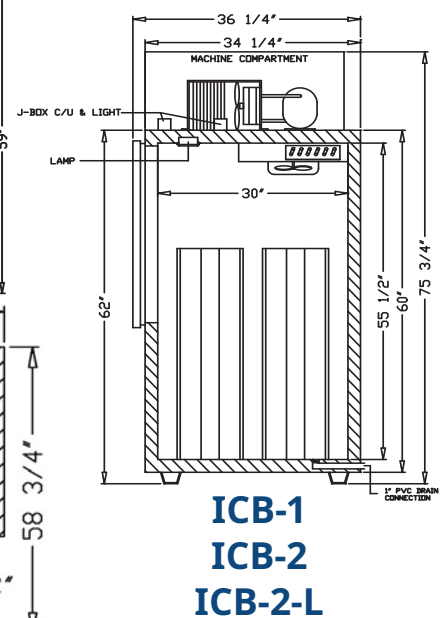

A Division of HMC Enterprises LLC • 831 East Cayuga St • Philadelphia, PA 19124 USA

(215) 464-6800 • 1-800-344-8222 • Fax (215) 969-4890 • E-Mail: sales@howardmccray.com • www.howardmccray.com