



RELIABILITY BUILT IN™

Limited One Year Warranty

T&S warrants to the original purchaser (other than for purposes of resale) that such product is free from defects in material and workmanship for a period of one (1) year from the date of purchase. During this one-year warranty period, if the product is found to be defective, T&S shall, at its options, repair and/or replace it. To obtain warranty service, products must be returned to...

*T&S Brass and Bronze Works, Inc.
Attn: Warranty Repair Department
2 Saddleback Cove
Travelers Rest, SC 29690*

Shipping, freight, insurance, and other transportation charges of the product to T&S and the return of repaired or replaced product to the purchaser are the responsibility of the purchaser. Repair and/or replacement shall be made within a reasonable time after receipt by T&S of the returned product. This warranty does not cover items which have received secondary finishing or have been altered or modified after purchase, or for defects caused by physical abuse to or misuse of the product, or shipment of the products.

Any express warranty not provided herein, and any remedy for Breach of Contract which might arise, is hereby excluded and disclaimed. Any implied warranties of merchantability or fitness for a particular purpose are limited to one year in duration. Under no circumstances shall T&S be liable for loss of use or any special consequential costs, expenses or damages.

Some states do not allow limitations on how long and implied warranty lasts or the exclusion or limitation of incidental or consequential damages, so the above limitations or exclusions may not apply to you. Specific rights under this warranty and other rights vary from state to state.

P/N: 098-009717-45 Rev.4

Date: 10-22-14

Drawn: TEH 10-22-14

Checked: JRM 11-04-14

Approved: JHB 11-10-14

Installation and Maintenance Instructions



WORKBOARD FAUCET B-1171 and B-1172 (with diverter valve)

Deutsch: Installations- und
Wartungsanleitun-
gen

Español: la Instalación y las
Instrucciones de
Mantenimiento

Français: les Instructions d'In-
stallation et d'Entre-
tien

Exploded View

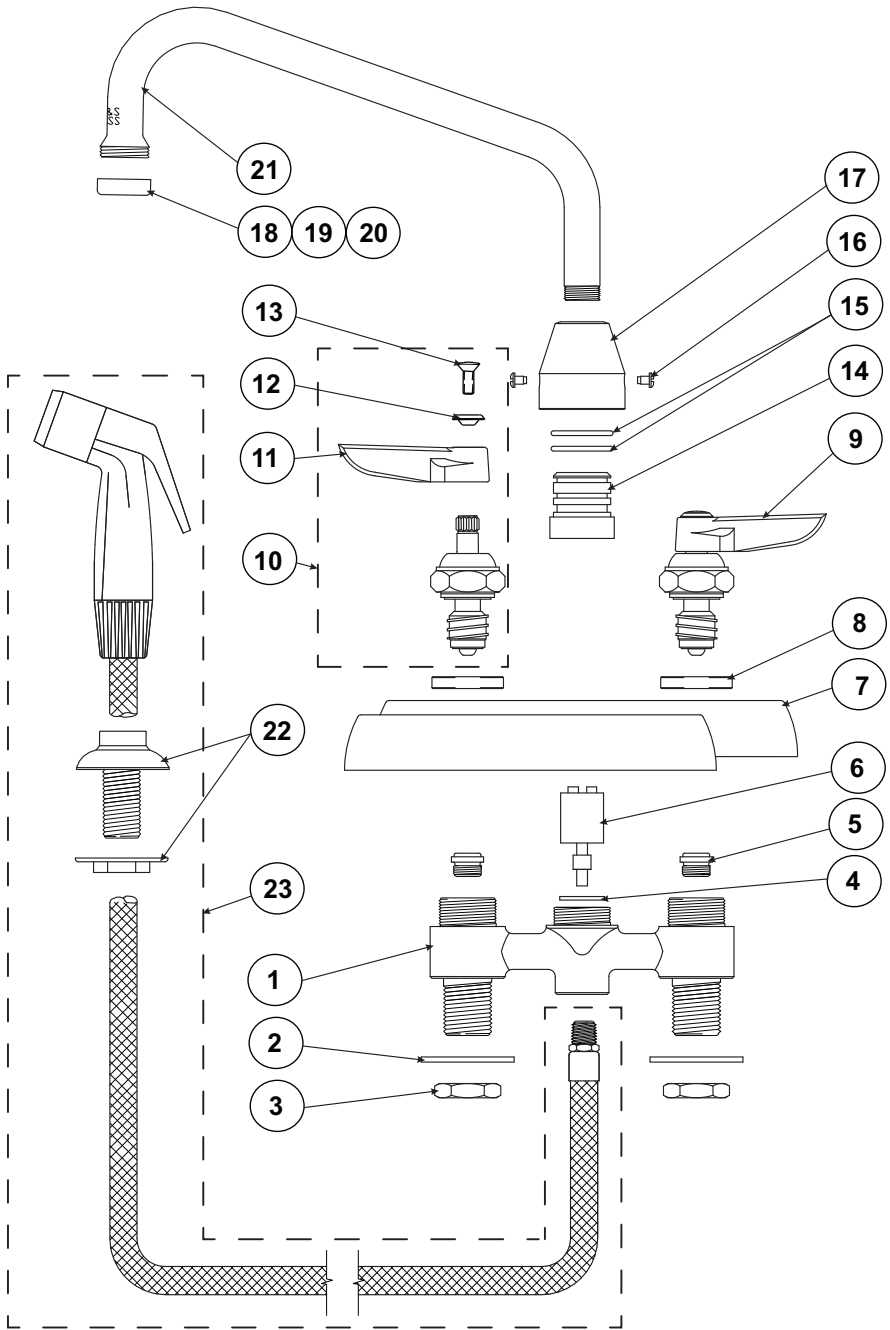

Part Number Guide

Base Faucet Assemblies

1	Base Faucet	N/A
2	Washer, Shank	000999-45
3	Locknut	002954-45
4	Washer	001043-45
5	Seat	000763-20
6	Valve, Diverter Piston	002338-45
7	Escutcheon Body (3-1/2" - 4" centers)	001258-40
	Escutcheon Body (8" centers)	001259-40
8	Locknut, Cover Plate	000712-25
9	Asm, Spindle - LTC, Includes Screw, Index & Handle	002709-40
	Asm, Spindle - RTC, Includes Screw, Index & Handle	002710-40
10	Spindle - LTC	009754-25
	Spindle - RTC	009753-25
11	Handle	001638-45
12	Index, Button - Blue	001660-45
	Index, Button - Red	001661-45
13	Screw, Lever Handle	000922-45
14	Adapter, Diverter	001484-20
15	O-Ring, Center Body	001069-45
16	Screw, Diverter Cover	001486-45
17	Cover, Diverter	001485-40

Nozzle Assemblies

18	Nozzle Tip	000863-25
19	Washer	001048-45
20	Screen	001323-45
21	Swing Nozzle	N/A
22	Hose Guide	001496-45
23	Hose Spray	001495-45

General Instructions

Nozzle Installation:

Note: Nozzle should be installed first.
See diagram below:

1. Place no.17 over no.14. Insert no.16 into each side of no.17.
2. Apply teflon tape or pipe joint compound to threaded end of no.21. Screw no.21 into no.17, rotate no.17 so that no.21 is facing front, tighten no.16.

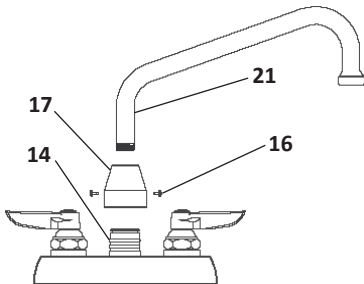

Faucet Installation:

3. Shut off water supply and drain lines. Drill (4) four holes, into countertop where you are installing no.1.

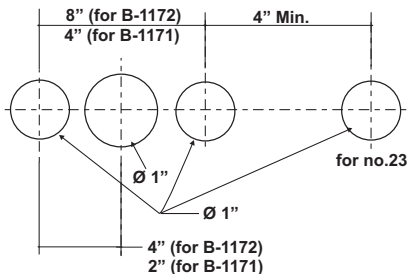

4. Place no.1 into the (3) three pre-drilled mounting holes.

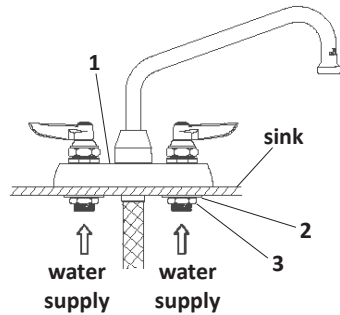

5. Reinstall no.2 and no.3 back onto no.1 shank under bottom of sink. Connect water supply to no.1.
6. Tighten no.3 with a wrench.

Spray Hose/Diverter Installation

7. Disassemble no.22, place shank of no.22 thru hole for no.23. Tighten locknut of no.22.

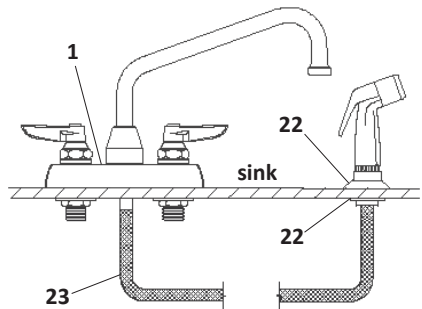

8. Apply teflon tape to threaded end of no.23. Insert no.23 through no.22 and attach to no.1.
9. Turn on water supply and check for leaks.

Instrucciones Generales

Instalación De La Boquilla:

Nota: La boquilla debe de ser instalada primero. Mire el dibujo de abajo:

1. Coloque la parte No.17 sobre la parte No.14. Coloque las partes No.16 dentro de ambos lados de la parte No.17.
2. Aplique cinta para rosca de tubería o compuesto de coyuntura al extremo con roscas de la parte No.21. Atornille la parte No.21 entre la parte No.17, gire la parte No.17 debido a que la parte No.21 esté oscilada hacia el frente, aprete la parte No.16.

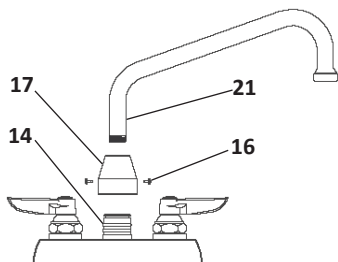

Instalación De La Canilla:

3. Cierre la fuente principal de agua y desagüe las tuberías. Perfore (4) cuatro huecos, en el mostrador donde será instalada la parte No.1.

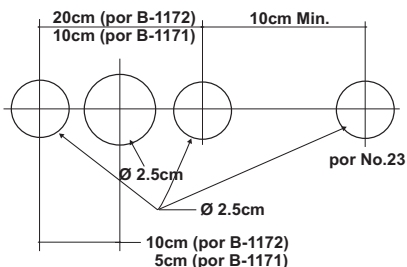

4. Coloque la parte No.1 entre los (3) tres huecos hechos anteriormente.

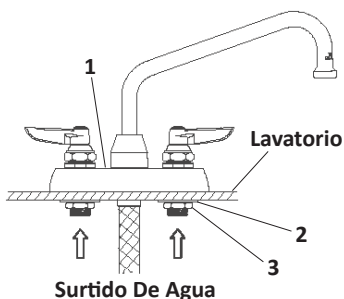

5. Instale de nuevo las partes No.2 y No.3 en el tronco de la parte No.1 debajo del fondo del lavatorio. Conecte el surtido de agua a la parte No.1.

6. Apriete No.3 con una llave.

Instalación Del Desviador para La Manguera Rociadora

7. Desarme la parte No.22, coloque el tronco de la parte No.22 a través del hueco para la parte No.23. Apriete la contra tuerca de la parte No.22.

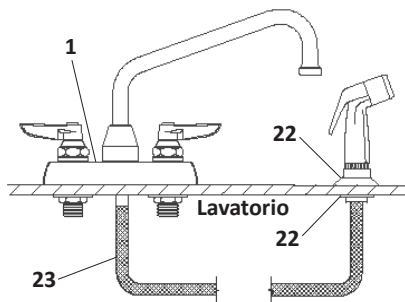

8. Aplique cinta para rosca de tubería al extremo con rosca de la parte No.23. Inserte la parte No.23 a través de la parte No.22 y júntelo a la parte No.1.

9. Abra la fuente de agua e inspeccione por filtraciones.

Instructions Générales

L'Installation De L'Ajutage:

Noter: Les ajutages doivent être installés au début. Voir le diagramme ci-dessous:

1. Mettre N°.17 sur N°.14. Insérer N°.16 dans chaque côté de N°.17.
2. Appliquer le ruban en Téflon ou le composé pour les tuyaux à l'extrémité avec les filets de N°.21. Visser N°.21 dans N°.17, tourner N°.17 jusqu'à N°.21 être en face, resserrer N°.16.

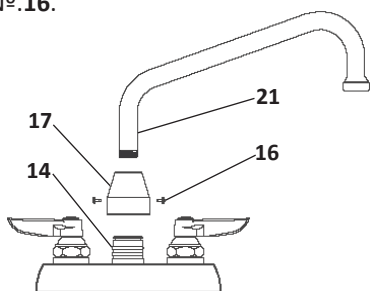

L'Installation Du Robinet:

3. Fermer la réserve de l'eau et égoutter la tuyauterie. Percer (4) quatre trous (3 trous pour B-1172) dans le comptoir où vous allez installer N°.1.

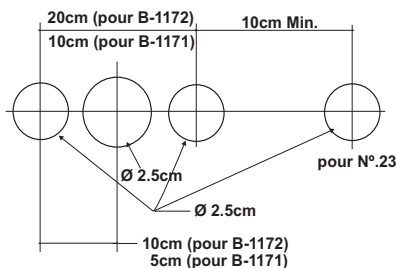

4. Mettre N°.1 dans les trois trous déjà préparés.

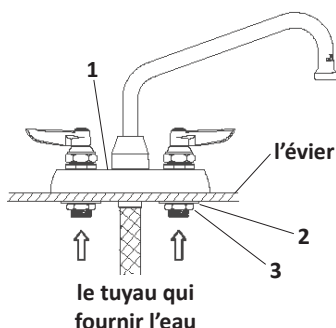

5. Réinstaller N°.2 et N°.3 sur la jambe au-dessous l'évier. Brancher le tuyau qui fournit l'eau à N°.1.
6. Resserrer N°.3 avec une clef.

Le Tuyau De Jet/ L'Installation D'Aiguillage:

7. Désassembler N°.22, mettre la jambe de N°.22 à travers le trou de N°.23. Resserrer l'écrou de N°.22.

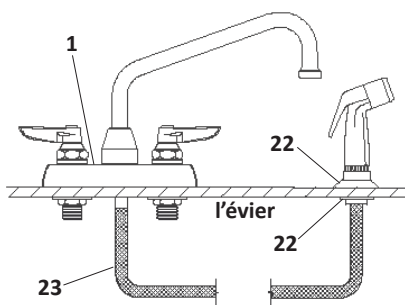

8. Appliquer le ruban en Téflon à l'extrémité avec les filets de N°.23. Insérer N°.23 à travers N°.22 et attacher à N°.1.
9. Recommencer l'eau et vérifier s'il y a des fuites.

Allgemeine Anleitungen

Schwenkhahninstallation:

Anmerkung: Der Schwenkhahn ist als erstes zu installieren. Siehe Zeichnung unten:

1. Nr.17 auf Nr.14 aufsetzen. Nr.16 in beide Seiten von Nr.17 einfügen.
2. Teflonband oder Rohrdichtmasse auf das Gewinde von Nr.21 auftragen. Nr.21 in Nr.17 einschrauben, Nr.17 so drehen, daß Nr.21 nach vorn ausgerichtet ist, Nr.16 anziehen.

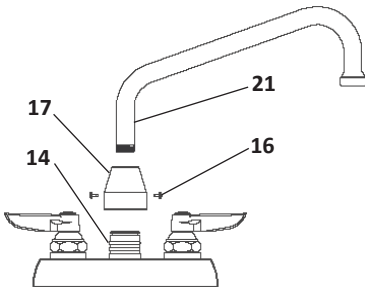

Armatureneinrichtung:

3. Wasserzufuhr abstellen und Leitungen entleeren. Vier (4) Löcher (3 Löcher für B-1172) in die Abdeckplatte bohren, wo Nr.1 installiert wird.

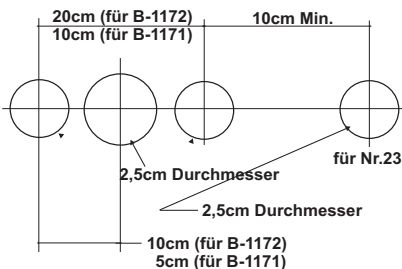

4. Nr.1 in die drei vorgebohrten Löcher einsetzen.

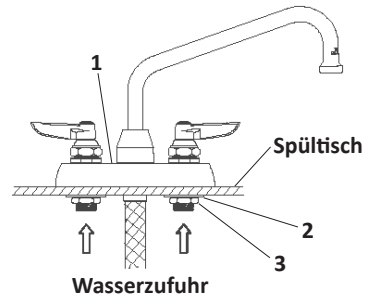

5. Nr.2 und 3 auf der Unterseite des Spültisches wieder auf den Schaft von 1 aufsetzen. Nr.1 mit der Wasserleitung verbinden.
6. Nr.3 mit einem Schraubenschlüssel anziehen.

Brausenschlauch/Installation des Umstellers

7. Nr.22 auseinandernehmen, Schaft von Nr.22 durch das Loch für Nr.23 stecken. Gegenmutter von Nr.22 anziehen.

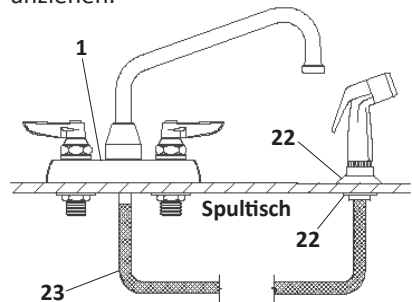

8. Das Gewinde von Nr.23 mit Teflonband umwickeln. Nr.23 durch Nr.22 hindurchstecken, Nr.22 anziehen.
9. Wasserzufuhr andrehen und auf Lecks prüfen.

RELATED T&S BRASS PRODUCT LINE



B-1125
Back-Mounted
Workboard Faucet

T&S BRASS AND BRONZE WORKS, INC.

A firm commitment to application-engineered plumbing products

2 Saddleback Cove, P.O. Box 1088,
Travelers Rest, SC 29690

Phone: (864) 834-4102

Fax: (864) 834-3518

E-mail: tsbrass@tsbrass.com

T & S Brass-Europe
'De Veenhoeve'
Oude Nieuwveenseweg 84
2441 CW Nieuwveen

The Netherlands



RELIABILITY BUILT IN™