

VICTORY[®]

ULTRASPEC

PROJECT: _____

ITEM # _____ QTY: _____

MODEL # _____

AIA # _____ SIS # _____

DUAL TEMP SOLID DOOR REACH-IN REFRIGERATOR/FREEZER

RFSA-2D-S1-HC



EXCLUSIVE WARRANTY

- ▶ 7 Year Parts, Labor and Compressor
- ▶ Exclusive 2 Year Warranty On Magnetic Door Gaskets
- ▶ Lifetime Warranty On Handles & Hinges (parts only)

CABINET CONSTRUCTION

- Stainless Steel Exterior
- Aluminum Interior
- Refrigerator Is On The Left And Freezer Is On The Right
- Stay-Open Door Feature For Easy Product Loading
- 20 Gauge Stainless Steel Door
- Magnetic Door Switch Automatically Activates Interior LED Light
- Heavy-Duty Cylinder Locks
- Stainless Steel Interior Door Liner
- Insulated Partition Wall Separates Compartments
- One Piece, Snap-In Magnetic Door Gaskets
- Low Profile Vertical Door Handles
- Hinged Front Shroud
- Energy Saving Thermal Breaker
- Stainless Steel Breaker Caps
- 6 Silver Freeze Wire Shelves
- 6" High Adjustable Stainless Steel Legs
- 8' Cord And Plug (see electrical data for details)

FEATURES

- Full Electronic Control With Touchpoint Interface
- Expansion Valve Technology
- Manager's Lockout Feature
- Anti-Condensate Perimeter Heater
- Variable Speed Compressor Technology

REFRIGERATION

- Refrigeration System Uses R-290 Refrigerant To Comply With All Environmental Concerns
- Hot Gas Condensate Evaporator
- Adaptive Defrost For Reduced Energy Consumption And More Consistent Product Temperatures
- Epoxy Coated Evaporator Coil, Located Out Of The Food Zone
- Refrigerator Capable Of Maintaining Product Temperature 36°F To 38°F
- Freezer Capable Of Maintaining Product Temperature -10°F



Please Verify Qualifying Units By Visiting:
www.energystar.gov/cfs

DUAL TEMP SOLID DOOR REACH-IN REFRIGERATOR/FREEZER

OPTIONS & ACCESSORIES

- | | | |
|------------------------------|---|--|
| • Stainless Steel Case Back | • Heat Shield (left, right) | • Tray Slides |
| • Exterior Door Laminate | • 6" Casters Or 6" Seismic Legs | • Door Swing Orientation (at time of order) |
| • Glass Door Models | • Optional Top Freezer/Bottom Refrigerator | • Correctional Package |
| • Stainless Steel Kick Plate | • Refrigerator FlexTemp Models Maintain Between 28°F And 38°F | • Remote Model* (6" legs only)
(refrigerant must be specified at time of order, see note) |
| • Additional Shelves | • Freezer FlexTemp Models Maintain Between 0°F And 20°F | |

3779 Champion Blvd, Winston-Salem, NC 27105

ph: (888) 845-9800 | fax: (800) 253-5168

Sales@VictoryRefrigeration.com | VictoryRefrigeration.com

Rev. 10/4/24 Printed in U.S.A.

APPROVAL: _____ DATE: _____

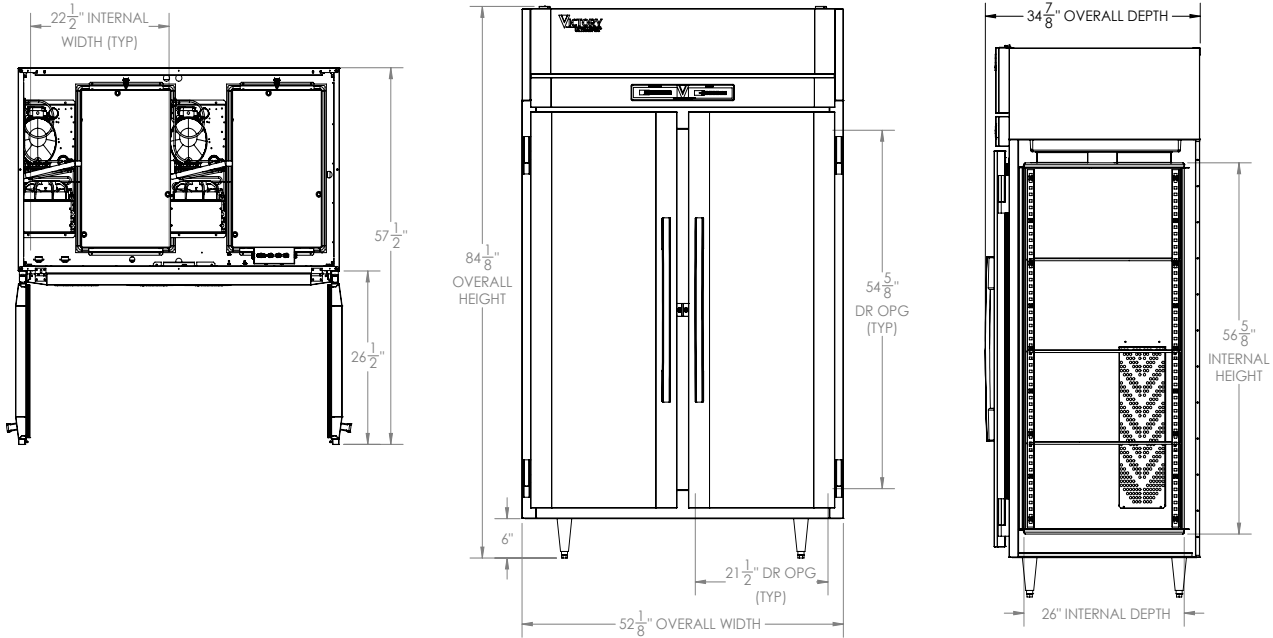

We reserve the right to change specifications and product design without notice. Such revisions do not entitle the buyer to corresponding changes, improvements, additions or replacements for previously purchased equipment. Dimensional tolerances +/- 1/4". Metric dimensions (MM)

12" Top clearance is required

CHARACTERISTICS		ELECTRICAL DATA		SHIPPING DETAILS	
Net Capacity (cubic ft.)	R 21.01 - F 21.01	Cabinet Voltage**	115/60/1	Height	88"
Width, Overall (in.)	52 1/8"	Total Amperes	R 6.5 - F 9.1	Width	60"
Depth, Overall (with handle)	34 7/8"	NEMA Plug (8' cord)	(2) 5-15P	Depth	45"
Height Overall (6" legs)	84 1/8"	REFRIGERATION DATA		Crated Weight	684 lbs
Depth, Door Open 90°	57 1/2"	Condensing Unit Size, HP	R 1/3 - F 3/4	*NOTE: Remote units are field wired and come with 6" legs. Refrigerant must be specified at time of order.	
Door Opening (in.)	21 1/2" x 54 5/8"	Refrigerant	R-290		
No. Of Doors/Shelves	2/6	Capacity (BTU/HR) (100°F/-20°F)	R 2800 - F 2450		
		Heat Rejection (BTU/HR)	7875		
		Charge (lbs/grams/ounces)	R .3307 / 150 / 5.29 F 0.2866 / 130 / 4.59		

** NOTE: This unit utilizes variable speed compressor technology. The compressor can experience nuisance tripping on Class A GFCI outlets which have a trip limit of 4 mA to 6 mA. To avoid this issue in a location that requires GFCI circuit protection, Victory recommends using either an Eaton, SCF20, or HUBBELL Model Number GFRST83W 20A Heavy Duty Hospital Grade Self-Test GFCI Receptacle.

3779 Champion Blvd, Winston-Salem, NC 27105 | ph: (888) 845-9800 | fax: (800) 253-5168

Sales@VictoryRefrigeration.com | VictoryRefrigeration.com

Rev. 10/4/24 Printed in U.S.A.