

# 3M™ Water Filtration Products

SPEC# \_\_\_\_\_

QUANTITY \_\_\_\_\_



models:

## HF160-CLS

3M™ Water Filtration Products High Flow Series Model HF160-CLS single cartridge water filtration system helps provide consistent high quality water for commercial food-service applications by reducing the effects of particulates, chloramines, cyst, bacteria and chlorine taste and odor at flow rates up to 2.2 gpm (8.3 lpm). Built-in scale inhibitor reduces the ability of calcium and magnesium to precipitate as hard scale.

### PRODUCT BENEFITS

- Cartridge media technology effectively reduces, particulates, chloramines, chlorine taste and odor for better equipment protection and premium Recipe Quality Water™.
- Revolutionary Integrated Membrane Pre-Activated Carbon Technology (“IMPACT”) dual-zone media cartridge construction combines a membrane in series with premium activated carbon to provide superior throughput and cartridge life.
- NSF Standard 42 and/or FDA CFR-21 compliant materials.
- NSF Standard 53 cyst reduction.
- Reduction of up to 99.99% of common water-borne bacteria by membrane filtration as tested by manufacturer’s lab.
- Built-in scale inhibitor reduces lime scale build-up
- Sanitary Quick Change (SQC) encapsulated cartridge design allows for fast and easy cartridge change-outs with ¼ turn.
- ½” FNPT horizontal inlet and outlet ports allow direct or easily adaptable connections to existing plumbing lines.

### PRODUCT SPECIFICATIONS

Model Number	Part Number	Reduction Claims	Nominal Micron Rating	Capacity	Service Flow Rate	Replacement Cartridge
HF160-CLS	56260-02	Bacteria <sup>1</sup> , Particulates, Chloramines <sup>2</sup> , Cyst, Scale, Chlorine Taste and Odor	0.2	4,700 gallons (17,790 liters)	2.2 gpm (8.3 lpm)	HF60-CLS (56259-02)

<sup>1</sup>As tested with E.Coli ATCC (11229) by manufacturer’s laboratory  
<sup>2</sup>Tested and verified by independent laboratory



# HF160-CLS

SPEC# \_\_\_\_\_  
 QUANTITY \_\_\_\_\_  
 MODEL NUMBER \_\_\_\_\_  
 PART NUMBER \_\_\_\_\_

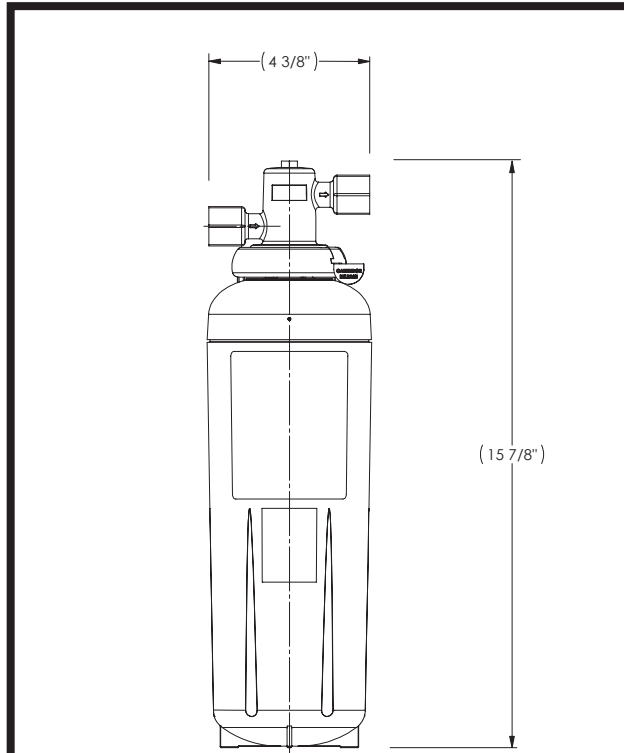

**⚠ WARNING: To reduce the risk associated with the ingestion of contaminants:**

- Do not use with water that is microbiologically unsafe or of unknown quality without adequate disinfection before or after the system. Systems certified for cyst reduction may be used on disinfected water that may contain filterable cysts. EPA Establishment #070595-CT-001

3M Purification Inc. recommends regularly scheduled maintenance and replacement of the filter cartridge(s) in order for the product to perform as advertised/sold. 3M Purification Inc. shall not be liable for system failures due to improper maintenance.

### LIMITED WARRANTY

3M Purification Inc. warrants this Product will be free from defects in material and manufacture for five (5) years from the date of purchase: The filter cartridge or filter membrane is warranted to be free from defects in material and manufacture for one (1) year. This warranty does not cover failures resulting from abuse, misuse, alteration or damage not caused by 3M Purification Inc. or failure to follow installation and use instructions. No warranty is given as to the service life of any filter cartridge or membrane as it will vary with local water conditions and water consumption. **3M PURIFICATION INC. MAKES NO OTHER WARRANTIES OR CONDITIONS, EXPRESS OR IMPLIED, INCLUDING, BUT NOT LIMITED TO, ANY IMPLIED WARRANTY OR CONDITION OF MERCHANTABILITY OR FITNESS FOR A PARTICULAR PURPOSE OR ANY IMPLIED WARRANTY OR CONDITION ARISING OUT OF A COURSE OF DEALING, CUSTOMER OR USAGE OF TRADE.** If the Product fails to satisfy this Limited Warranty during the warranty period, 3M Purification Inc. will replace the Product or refund your Product purchase price. This warranty does not cover labor. **The remedy stated in this paragraph is Customer's sole remedy and 3M Purification Inc.'s exclusive obligation. For additional information, see the entire Limited Warranty located in the product Installation and Operating Instruction Manual.**

**Limitation of Liability.** 3M Purification Inc. will not be liable for any loss or damage arising from this 3M Purification Inc. product, whether direct, indirect, special, incidental, or consequential, regardless of the legal theory asserted, including warranty, contract, negligence or strict liability. Some states and countries do not allow the exclusion or limitation of incidental or consequential damages, so the above limitation or exclusion may not apply to you.

# 3M™ Water Filtration Products

## APPLICATION GUIDE

Application	
<b>Medium to High Volume Coffee</b>	
1, 2 and 3 Warmer Brewers, Liquid Coffee, Airpot Brewers and 3 Gallon Urns	1/2 Gal. Pots: 9,400 3 Gal. Ums: 1,566 12 oz. Cups: 50,133 2.5 Liter Airpots: 7,121
<b>Medium to High Volume Tea/Iced Tea</b>	
3, 3.5, and 4 Gallon Tea and Iced Tea Brewers	3 Gal. Dispensers: 1,566 3.5 Gal. Dispensers: 1,342 4 Gal. Dispensers: 1175 5 Gal. Dispensers: 940 12 oz. Cups: 50,133
<b>Ice Machines</b>	
Commercial Cubers	Up to 300 lbs

## IMPORTANT: INSTALLATION TIPS

These installation tips are for informational purposes only and are not intended to be used as actual installation instructions. **CAUTION: To reduce the risk associated with property damage due to water leakage:**

- **Read and follow** Use Instructions before installation and use of this system.
- Installation and use **MUST** comply with all state and local plumbing codes.
- **Protect from freezing**, remove filter cartridge when temperatures are expected to drop below 40°F (4.4°C).
- **Do not install on hot water supply lines.** The maximum operating water temperature of this filter system is 100°F (37.8°C).
- **Do not install** if water pressure exceeds 125 psi (862 kPa). If your water pressure exceeds 80 psi (552 kPa), you must install a pressure limiting valve. Contact a plumbing professional if you are uncertain how to check your water pressure.
- **Do not install** where water hammer conditions may occur. If water hammer conditions exist you must install a water hammer arrester. Contact a plumbing professional if you are uncertain how to check for this condition.
- The disposable filter cartridge **MUST** be replaced every 12 months, at the rated capacity or sooner if a noticeable reduction in flow rate occurs.



3M Purification Inc.  
 400 Research Parkway  
 Meriden, CT 06450 U.S.A.  
 Toll Free: 1.888.218.2866  
 Worldwide: 203.237.5541  
 Fax: 203.238.8701  
 www.3mpurification.com



Visit [www.nsf.org](http://www.nsf.org) for the claims associated with products that are NSF listed.

3M is a trademark of 3M Company.  
 NSF is a trademark of NSF International.  
 Recipe Quality Water is a trademark of 3M Company.  
 © 2011 3M Company. All rights reserved.  
 70-0202-6742-6  
 REV 0611