



Profit from the Eagle Advantage®

# Specification Sheet

## Short Form Specifications

Eagle Floor Mounted Mop Sink, model \_\_\_\_\_.  
Constructed of type 304 stainless steel, with 8" or 12" deep-drawn covered corner sink with drain and flat strainer plate.



#F1916 mop sink

## Options / Accessories

- 3-Pole mop holder
- 4-Pole mop holder
- Hose and bracket
- Service faucet
- Splash kit

## EAGLE GROUP

100 Industrial Boulevard, Clayton, DE 19938-8903 USA  
 Phone: 302-653-3000 • 800-441-8440 • Fax: 302-653-2065  
[www.eaglegrp.com](http://www.eaglegrp.com)  
[www.eaglegrpnews.com](http://www.eaglegrpnews.com)  
[www.eaglemhc.com](http://www.eaglemhc.com)

For custom configuration or fabrication needs, contact our **SpecFAB® Division**.  
 Phone: 302-653-3000 • Fax: 302-653-2065 • e-mail: [quotes@eaglegrp.com](mailto:quotes@eaglegrp.com)

Item No.:	_____
Project No.:	_____
S.I.S. No.:	_____

## Mop Sinks

### MODELS:

- |                                   |                                 |                                 |                                 |
|-----------------------------------|---------------------------------|---------------------------------|---------------------------------|
| <input type="checkbox"/> F1916    | <input type="checkbox"/> 312688 | <input type="checkbox"/> 503095 | <input type="checkbox"/> 503099 |
| <input type="checkbox"/> F1916-12 | <input type="checkbox"/> 321561 | <input type="checkbox"/> 503096 | <input type="checkbox"/> 503100 |
| <input type="checkbox"/> F2820    | <input type="checkbox"/> 312689 | <input type="checkbox"/> 503097 |                                 |
| <input type="checkbox"/> F2820-12 | <input type="checkbox"/> 312690 | <input type="checkbox"/> 503098 |                                 |

### Sink Bowl

- Heavy gauge type 304 stainless steel.
- Deep-drawn one piece seamless construction, using state-of-the-art hydraulic presses.
- Generous radius with a minimum dimension of 3" (76mm), rectangular for maximum capacity.
- Drain is 2" (51mm) NPS nickel-plated cast bronze body, with removable snap-on stainless steel flat strainer plate.
- Models #F1916 and F2820 feature 8" (203mm) water level with 8 3/4" (222mm) flood level. Models #F1916-12 and F2820-12 feature 12" (610mm) water level with 12 3/4" (324mm) flood level.

### Top

- 16 gauge type 304 stainless steel.
- Exclusive anti-splash double-offset "V" edge prevents spillage.

### Skirt

- Heavy gauge type 304 stainless steel.
- Stud-bolted to underside of top in a concealed manner, providing a clean visual appearance.
- Full skirt allows for tight sanitary seal.

### Design and Construction Features

- A superior floor sink designed for institutional use as well as those installations which require quality and durability.
- Entire top assembly is fused, welded, and planished, providing a one-piece seamless floor sink.
- Welded areas are high-speed belt blended to match adjacent surfaces with continuity of satin finish.
- Water supply is 1/2" (13mm) IPS for hot and cold lines.
- Wall-mount faucets are available as options.

### Certifications / Approvals



## AUTOQUOTES



EG20.01 Rev. 04/23

Spec sheets available for viewing, printing or downloading from our online literature library at our websites

Eagle Foodservice Equipment, Eagle MHC, and SpecFAB® are divisions of Eagle Group. ©2023 by the Eagle Group



Profit from the Eagle Advantage®

Item No.: \_\_\_\_\_  
 Project No.: \_\_\_\_\_  
 S.I.S. No.: \_\_\_\_\_

## Mop Sinks

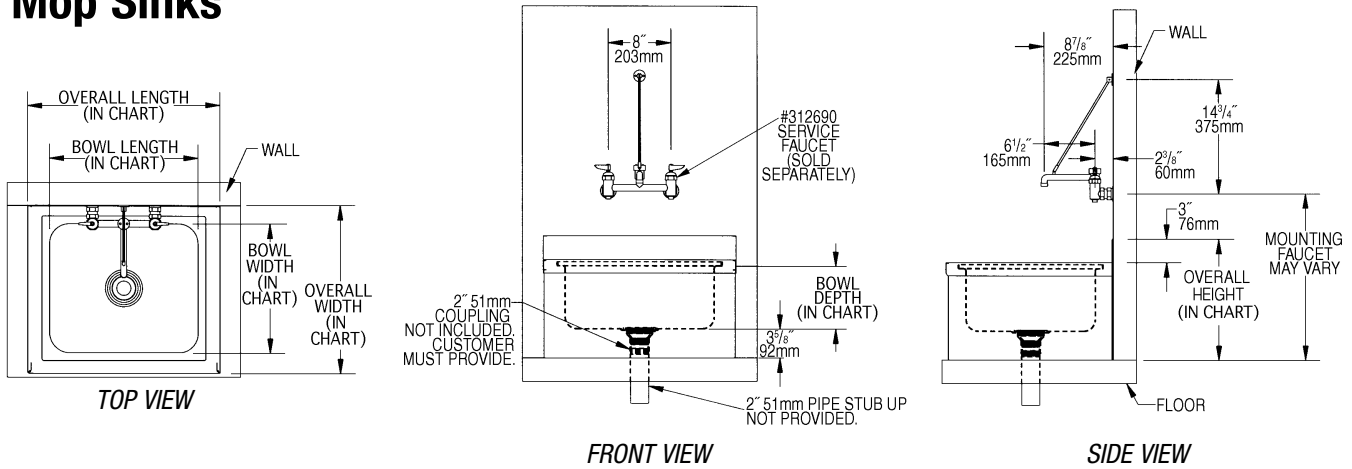

model #	bowl size		overall size		weight	
	width in.	length x depth mm	width in.	length x height mm	lbs.	kg
<b>F1916</b>	16" x 20" x 8"	406 x 508 x 203	21 1/2" x 24 3/4" x 15 1/2"	546 x 625 x 394	35	15.8
<b>F1916-12</b>	16" x 20" x 12"	406 x 508 x 305	21 1/2" x 24 3/4" x 19 1/2"	546 x 625 x 495	53	24.0
<b>F2820</b>	20" x 28" x 8"	508 x 711 x 203	25" x 32 1/2" x 15 1/2"	635 x 826 x 394	68	30.8
<b>F2820-12</b>	20" x 28" x 12"	508 x 711 x 305	25" x 32 1/2" x 19 1/2"	635 x 826 x 495	86	39.0

### Optional Accessories for Mop Sinks

model #	description	weight lbs.	kg
<b>312688</b>	3-pole mop holder, 18" x 4" (457 x 102mm), projects out 2 1/8" (54mm)	4	1.8
<b>321561</b>	4-pole mop holder, 24" x 4" (610 x 102mm), projects out 2 1/8" (54mm)	4.5	2.0
<b>312689</b>	Hose & bracket, 30" (762mm) length	8	3.6
<b>312690</b>	Service faucet, 8" (203mm) center, 1/2" (13mm) NPT female inlets, comes with vacuum breaker	11	5.0

### 16" Splash Kits

16/304 stainless steel. 3" (76mm) radius on front of splashes. Kits come with hardware for attaching to mop sink.



description	fits "F1916" Mop Sinks	fits "F2820" Mop Sinks
left and rear splash kit	<b>503095</b>	<b>503098</b>
right and rear splash kit	<b>503096</b>	<b>503099</b>
left, right and rear splash kit	<b>503097</b>	<b>503100</b>

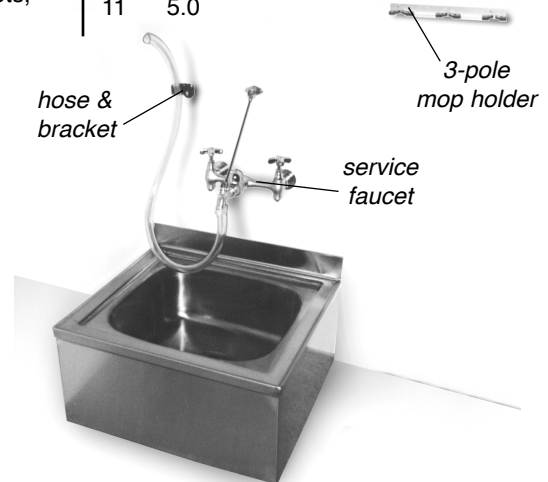

### EAGLE GROUP

100 Industrial Boulevard, Clayton, DE 19938-8903 USA  
 Phone: 302-653-3000 or 800-441-8440 • Fax: 302-653-2065  
 www.eaglegrp.com • www.eaglegrpnews.com • www.eaglehmc.com

Printed in U.S.A.  
 ©2023 by Eagle Group

Rev. 04/23

Spec sheets available for viewing, printing or downloading from our online literature library at our websites

Although every attempt has been made to ensure the accuracy of the information provided, we cannot be held responsible for typographical or printing errors. Information and specifications are subject to change without notice. Please confirm at time of order.