



60" Upright Bins

Model Number
1325
1665



1665 shown

FEATURES

- Stainless steel front and sides
- Galvanized steel back and bottom
- Large opening for scoop dispensing
- Seamless polyethylene liner with coved corners
- 1 1/2" foamed in-place polyurethane insulation
- Stainless steel baffle prevents ice overflow
- Adjustable feet
- Factory installed 1" NPS stainless steel drain
- Spring loaded door hinge
- Transparent view windows



Toll Free Phone: 1-800-346-3246

Local Phone: (303) 761-1615

E-mail: sales@kloppenberg.com

www.kloppenberg.com

ASSEMBLY REQUIRED

- Snout (tool-free)
- Feet

Model Number
1325
1665

60" Upright Bins

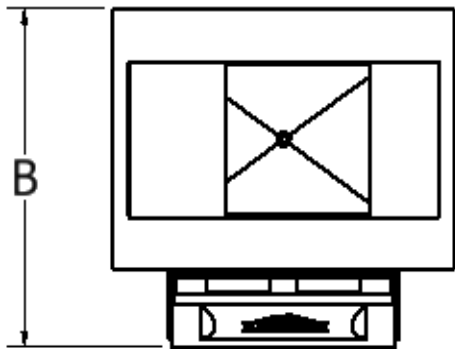

TOP VIEW

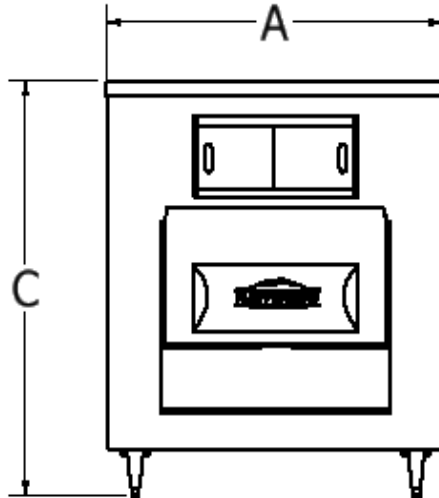

FRONT VIEW

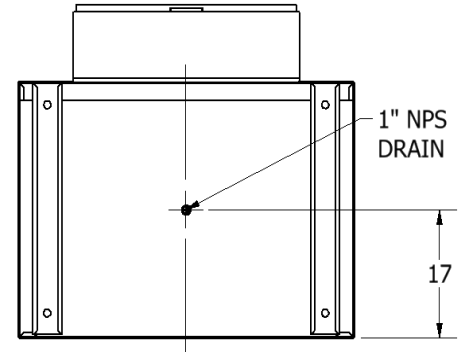

BOTTOM VIEW

Model Number	Capacity lbs (kg)	A-Width in (mm)	B-Depth* in (mm)	C-Height in (mm)	Minimum Door Clearance	Ship Weight lbs (kg)
1325	1,471 (667)	60 (1,524)	44.5 (1,130)	55 (1,397)	34 (864)	340 (155)
1665	1,846 (837)	60 (1,524)	44.5 (1,130)	67 (1,727)	34 (864)	390 (177)

*Includes 10.5" depth for snout

OPTIONS:

- Stainless Steel liner
- Fully welded stainless steel liner (coved corners)
- Prison Package
- Flanged feet

AVAILABLE ACCESSORIES:

- Paddle
- Scoops
- Totes
- Bagging Kit
- Carts

Toll Free Phone: 1-800-346-3246 Local Phone: 303-761-1615

Email: sales@kloppenberg.com

Please send all PO's to purchaseorders@kloppenberg.com