



KMD-355/505M_J(Z)

MODULAR CRESCENT CUBER

KMD-355/505M_J(Z)
10/31/24
Item #13683



W x D x H
30" x 24" x 22"

Air-Cooled

KMD-355MAJ
KMD-505MAJ

Water-Cooled

KMD-355MWJ
KMD-505MWJ

Remote Air-Cooled

KMD-505MRJZ



Air-cooled model shown on Lancer Dispenser



Air-cooled model shown on DB-130H Bin



Air-cooled model shown on BD-500SF

KMEdge™ Cube Dimensions*

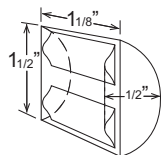



* approximate size in inches, image not to scale



Item #: _____
Project: _____
Qty: _____
AIA#: _____

Features

- ▶ Individual crescent cube
 - ▶ Optimized for use with ice and beverage dispenser
 - ▶ Simple one-hour cleaning process 
 - ▶ Factory-installed ultrasonic bin control can be adjusted on site
- Durable construction with fewer parts
 - Self-diagnostic programming automatically adjusts to changing conditions
 - Snap fit parts for easy cleaning
 - Stainless steel double-sided evaporator
 - CycleSaver™ design 
 - EverCheck™ alert system 
 - Removable air filters (air-cooled model only)
 - R-404A Refrigerant

Available on Bins:

B-250SF **BD-500SF**** **B-800SF** **B-1150SS** **DB-130H**
B-500SF **B-700SF** **B-900SF** **B-1300SS** **DB-200H**

Top kit may be required. See bin spec sheets. **BD bins recommended

Warranty:

3 Year Parts & Labor on entire machine. 5 Year Parts & Labor on Evaporator. 5 Year Parts on Compressor; air-cooled condenser coil. Valid in United States, Canada, Puerto Rico and U.S. Territories. Contact factory for warranty in other countries.

Shipping: (LxWxH) 33.75" x 33.25" X 28" Volume: 18.18ft³

Condenser	Model	ICE PRODUCTION		WATER USAGE			ELECTRICAL						
		Air / Water Temp Lbs. per 24 hours 70°/50°F	90°/70°F	Potable Gal. per 100 lbs. 90°/70°F	Condenser Gal. per 100 lbs. 90°/70°F	kWh Used per 100 lbs. 90°/70°F	Min. Circuit/ Max. Fuse Size	Amperage	Voltage	Circuit Wires (including ground)	Heat Rejection BTU/hr.	Refrigerant Charge Amount	Net / Ship Weight (lbs.)
Air	KMD-355MAJ	395	352	26.5	N/A	5.80	15A	8.8A	115V/60/1	3	5,100	1 lb. 9.6 oz.	159 / 179
Water	KMD-355MWJ	395	385	34.5	155	4.40	15A	7.4A	115V/60/1	3	6,000	0 lb. 15 oz.	159 / 179
Air	KMD-505MAJ	500	415	25.0	N/A	5.55	20A	10.7A	115V/60/1	3	6,000	1 lb. 8.7 oz.	156 / 176
Water	KMD-505MWJ	592	555	25.0	178	4.15	20A	11A	115V/60/1	3	8,600	15.9 oz.	156 / 176
Remote	KMD-505MRJZ	560	490	25.0	N/A	5.70	20A	12.4A	115V/60/1	3	7,900	2 lb. 13.9 oz. (4 lb. 11.8 oz.*)	156 / 176

*(with condenser)

Operating Limits

- Ambient Temp Range 45 - 100°F
- Water Temp Range 45 - 90°F
- Water Pressure 10 - 113 PSIG
- Voltage Range 104 - 127V
- If GFCI is required, a GFCI breaker MUST be used in lieu of GFCI receptacle

Service

- Panels easily removed and all components accessible for service.
- Removable/cleanable air filters. (Air-cooled model only)
- Allow 6" (15 cm) clearance at rear, sides, and top for proper air circulation and ease of maintenance/service.

Plumbing

- Icemaker Water Supply Line: Min. 1/4" Nominal ID Copper Water Tubing or Equivalent
- Icemaker Drain Line: Min. 3/4" Nominal ID Hard Pipe or Equivalent
- Water-Cooled Model (Lines Must Be Independent of Icemaker)
- Condenser Water Supply Line: Minimum 1/4" Nominal ID Copper Water Tubing or Equivalent
- Condenser Drain/Return Line: Minimum 1/4" Nominal ID Hard Pipe (open drain system) or Copper Water Tubing (closed loop system) or Equivalent

Accessories

- HS-2148, DB Top Kit
- HS-5562, Remote Monitoring System
- HS-5283, Eco Ice Filter
- HS-5734, Side-Breathing Kit
- H9320-51, Single Water Filter Kit

Hoshizaki reserves the right to change specifications without notice.



KMD-355/505M_J(Z)

MODULAR CRESCENT CUBER

KMD-355/505M_J(Z)

10/31/24

Item #13683

FRONT VIEW

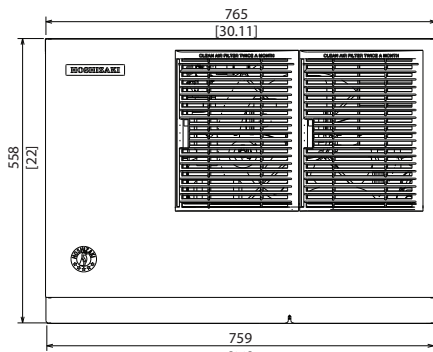

AIR-COOLED

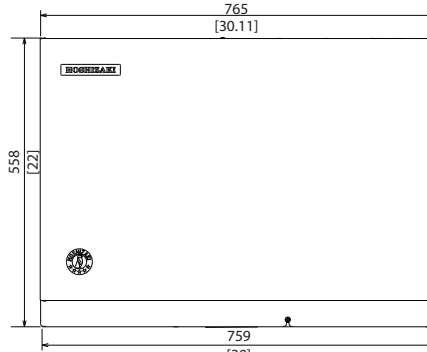

WATER-COOLED / REMOTE AIR-COOLED

mm
inch

SIDE VIEW

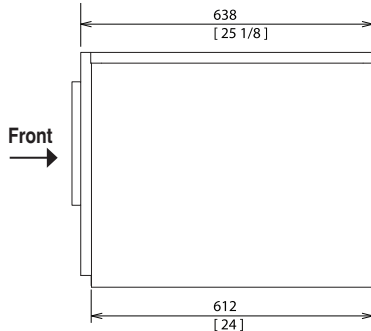

AIR-COOLED

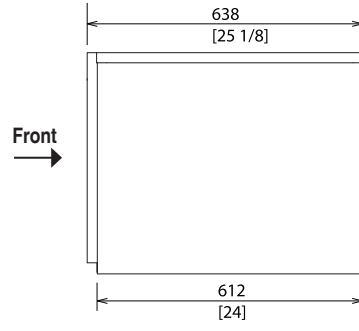

WATER-COOLED / REMOTE AIR-COOLED

BOTTOM VIEW

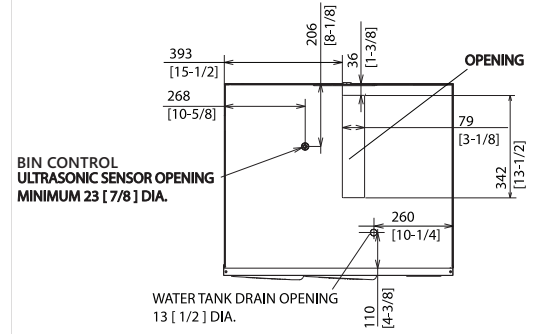

BIN CONTROL
ULTRASONIC SENSOR OPENING
MINIMUM 23 [7/8] DIA.

WATER TANK DRAIN OPENING
13 [1/2] DIA.

AIR-COOLED / WATER-COOLED / REMOTE AIR-COOLED

REAR VIEW

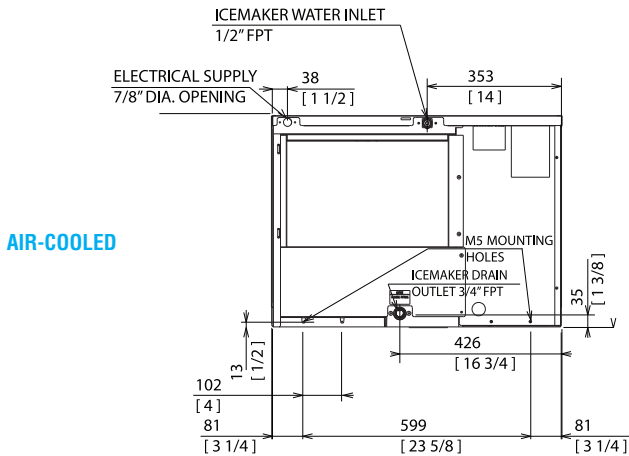

AIR-COOLED

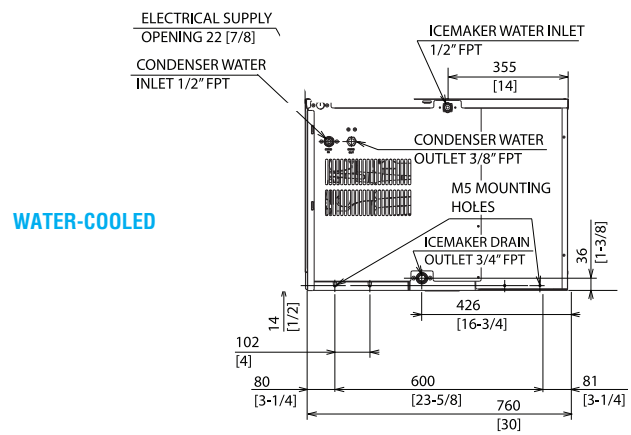

WATER-COOLED

REMOTE AIR-COOLED

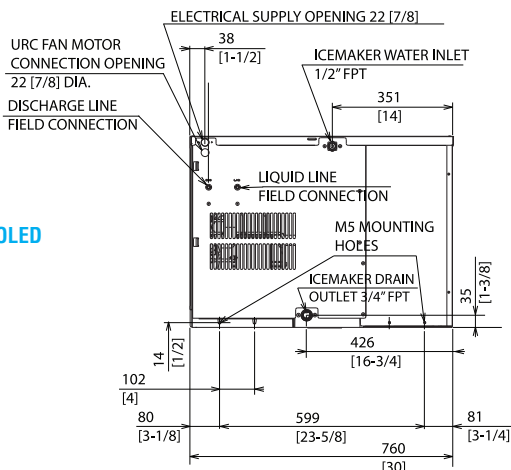

REMOTE CONDENSER
For Use with KMD-505MRJZ

URC-5FZ Remote Condenser (Sold Separately)
(W x D x H) 21^{13/16} x 14^{1/16} x 32^{13/16}

Brazed Line Sets
(Sold Separately)
25' HS-5587
35' HS-5588

Voltage supply for ice
maker and condensing
unit are separate.

