

Water Boost & LVPO Filtration

2 Gallon Water Boost and Integrated LVPO F1 Filtration.

SHURflo®

APPLICATIONS

Fountain

FEATURES & BENEFITS

Compact design provides boosted filtered water to the fountain system and treated non-boosted water to the ice machine

Specifically designed for low syrup volume accounts

Proprietary filter media with gradient depth and radial flow design resulting in maximized filter life

Eliminates carbon fine buildup in soda valves

Improved water quality for great tasting beverages

Low Pressure Drop (less than 8 psi at 3.0 gpm) helps keep consistent Brix ratio

SHURlock Quick Connect fittings

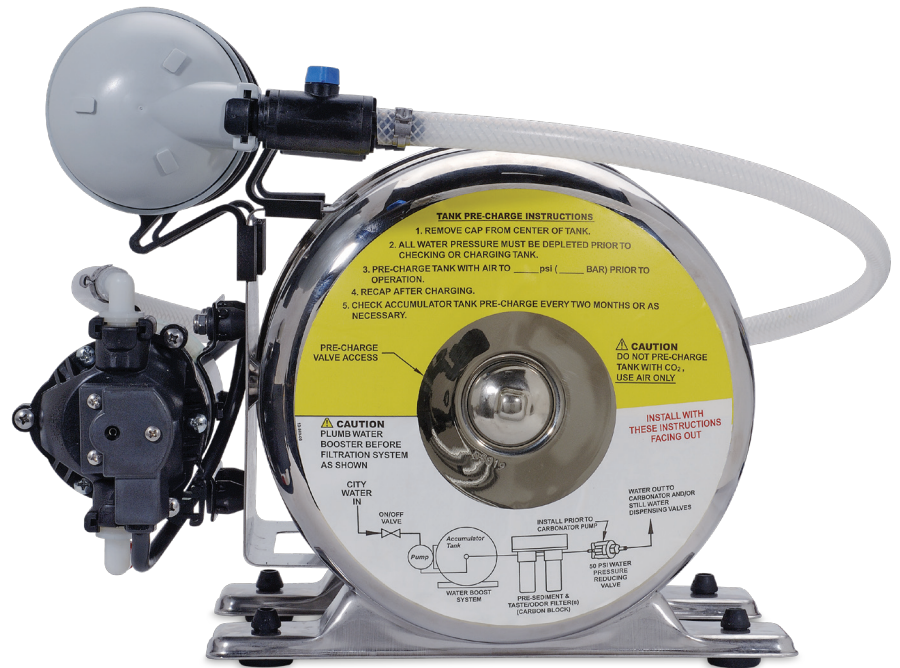

WB2-LVPO-01

Replacement Parts

- 94-399-00 LVPO F1 Replacement Filter
- 94-471-00 Quick Connect 3/8" Barb Ball Valve
- 94-471-01 Quick Connect 1/2" NPT
- 94-475-00 LVPO Filter QD Bypass
- 94-472-00 Filter Bracket For Tank Mount

SPECIFICATIONS

- Booster Pump:** SHURflo 90 psi 115 VAC 8000 series corded pump (NSF listed)
- Accumulator Tank:** 2 gallon SS (NSF listed)
- Filtration:** LVPO-F1 Filter 5.0 Micron Carbon Block media for Chlorine taste & Odor reduction
- Water Ports:** 3/8" barb inlet/outlet
- Pre-charge:** 50 psi (recommended for most beverage applications)
- Draw down volume:** 0.75 gallon (@50 psi pre-charge)
- Dimensions:** 13.5" H x 14" W x 17" D
- Weight:** 18 pounds (empty)

- LVPO-F-1** For Chlorine Taste & Odor reduction & 5 μ particulate reduction 6,000 gal. [22,712 Liters] @ 3.0 gpm [11.4 lpm]

SHURflo Water Boost Systems are warranted to be free of defects in material and workmanship under normal use for a period of one (1) year from the date of manufacture, with proof of purchase. This limited warranty will not exceed two (2) years, in any event. This limited warranty will not apply to Water Boost Systems that were improperly installed, misapplied or incompatible with fluids or components not manufactured by SHURflo. Water Boost System failure due to foreign debris is not covered under the terms of this limited warranty. SHURflo will not warrant any Water Boost System which is damaged or modified outside of the SHURflo factory. Returns are shipped postage prepaid to service center in Hanover Park, IL. SHURflo shall not be liable for freight damage during shipping. Package returns carefully.

Water Boost & LVPO Filtration

WB2-LVPO-01

INSTALLATION TIPS

Check precharge at time of installation is at 50 PSI

Check tank precharge each service visit to ensure optimum performance

Do not charge accumulator tank with CO₂

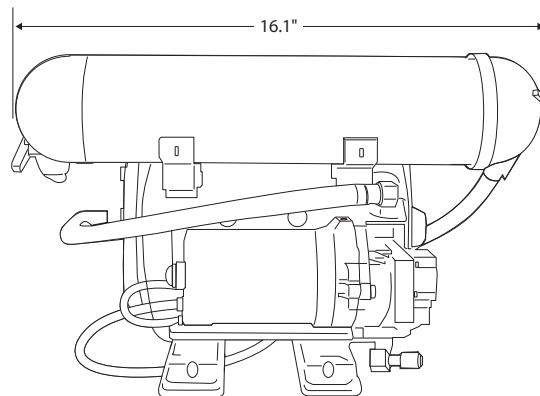
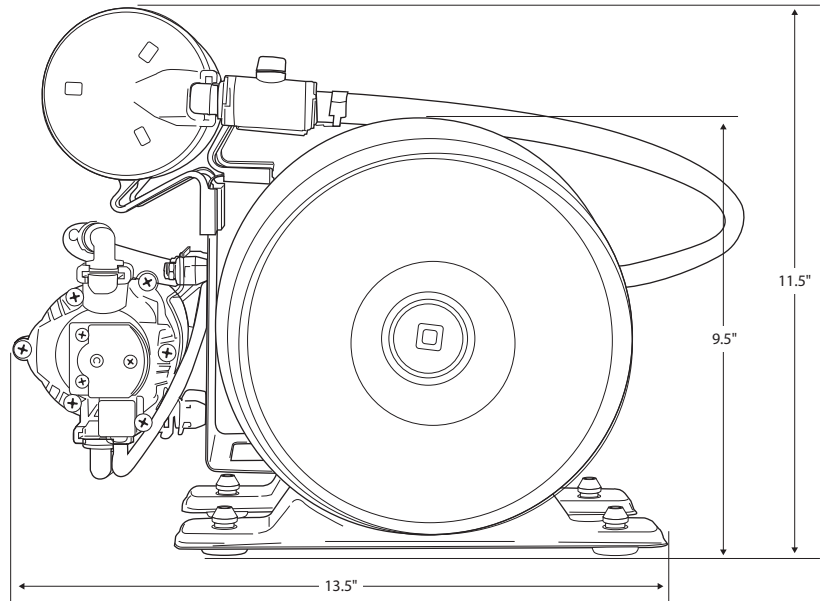

SHURflo reserves the right to update specifications, change prices, or make substitutions without notice.

WB2-LVPO-01

JA10

Everpure-Shurflo India
A-25
Mohan Co-operative Industrial Estate
Mathura Road
New Dehli, 110 044
INDIA
TEL: 011.661.188.00
FAX: 011.661.188.22

Everpure-Shurflo Japan LLC
Hashimoto MN Bldg. 7F
3-25-1 Hashimoto Sagamihara-Shi
Kanagawa 229-1103
JAPAN
TEL: 81.(0)42.775.3011
FAX: 81.(0)42.775.3015

Everpure-Shurflo China
21F Cloud 9 Plaza, No 1118,
West Yan'an Road, Changning District
Shanghai, 200052
CHINA
TEL: 86.21.3211.4588
FAX: 86.21.3211.4580

SHURflo®
First in Fluid Innovation
Visit our website at www.shurflo.com

Pentair Filtration Solutions, LLC
World Headquarters-Everpure/Shurflo
North and South America Sales
1040 Muirfield Dr.
Hanover Park, Illinois 60133
USA
TEL: 800.323.7873 (US only)
TEL: 630.307.3000
FAX: 630.307.3030

Everpure-Shurflo Australia
2 Redwood Drive
Notting Hill
Victoria, 3168
AUSTRALIA
TEL: 011.61.39.574.4000
FAX: 011.61.39.562.7237

Everpure-Shurflo Southeast Asia
18 Boon Lay Way
#04-110/111
TradeHub 21, 609966
SINGAPORE
TEL: 65.6795.2213
FAX: 65.6795.2219

Everpure-Shurflo Europe bvba
Industriepark Wolfstee
Toekomstlaan 30
B-2200 Herentals
BELGIUM
TEL: +32.(0).14.283.500
FAX: +32.(0).14.283.505