

RNK-1100

Nugget Ice Machine

Models

RNK-1100A



RNK-1100A Nugget Ice Machine on D-570 Bin

Standard Features

- Bite sized nugget with 85% ice content offers one of the best ice to water ratios for maximum cooling and minimal drink dilution
- Up to 525 kgs (1,158 lbs) of daily ice production
- Perfect for beverage applications, dispensing, smoothies, and cold therapy
- Can be paired with any 30" Multiplex beverage dispenser for an unbeatable soft-drink experience
- High load maintenance free bearings for enhanced reliability
- Evaporator is designed for maximum quality and operating life
- Heavy duty stainless steel cabinet resists corrosion

COMMERCIAL WARRANTY

<p>ICE MAKER</p> <p style="font-size: 2em;">3</p> <p>YEAR PARTS</p>	<p>COMPRESSOR</p> <p style="font-size: 2em;">3</p> <p>YEAR LABOR</p>	<p style="font-size: 2em;">5</p> <p>YEAR PARTS</p> <p>3 YEAR LABOR</p>
---	--	---

Specifications

<p>BTU Per Hour: 7,500 (average)</p> <p>Compressor: Nominal rating: ? HP</p> <p>Refrigerant: R452A</p>	<p>Operating Limits:</p> <ul style="list-style-type: none"> • Ambient Temperature Range: 14.4°-37.8°C (50°-100°F) • Water Temperature Range: 7.2°-32.2° C (45°-90° C) • Water Pressure Ice Maker Water In: Min. 1 bar (14 psi) Max. 6 bar (84 psi)
---	--

Ice Machine Electric

220-240/50/1

Ave power consumption: 1,415 W

Maximum fuse size: 16 amp

Ice Shape

Nugget ice consists of small pieces ranging from 0.95cm to 1.27cm in width and length. Offers a 85% ice to water ratio with a soft, chewable texture while still providing maximum cooling effect and dispensability.



Ice shown actual size



www.manitowocice.com

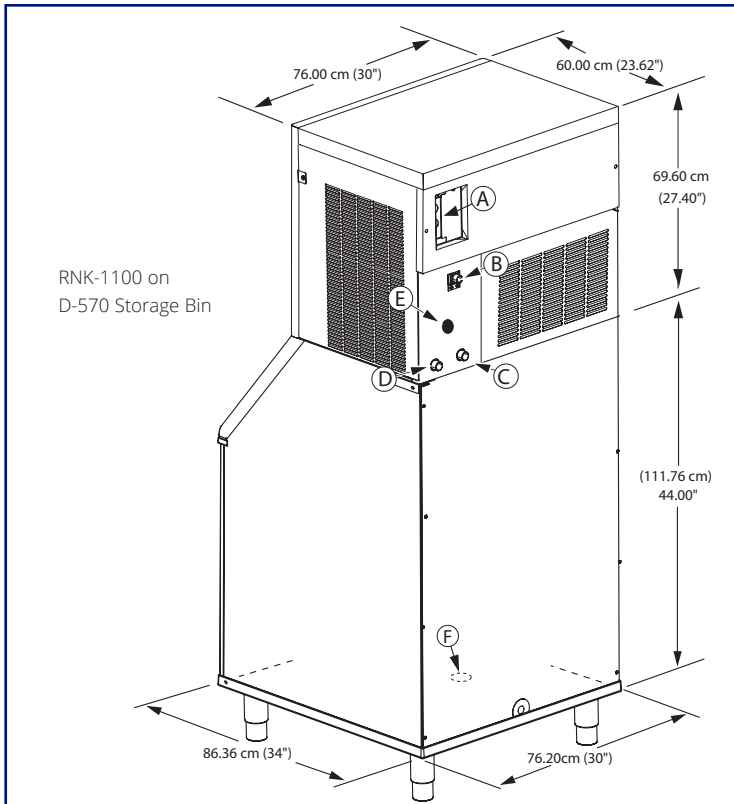

RNK-1100 on
D-570 Storage Bin

Installation Note -
Minimum installation clearance: Top/sides: 20.32 (8"), back: 12.7cm (5").

Dispenser Note -
Verify with the dispenser manufacturer that the correct agitator and deflector kit for nugget ice dispensing is included with your dispenser purchase.

- (A) Electrical Entrance (2) Options
- Air-Cooled Units:**
 - (B) 0.95cm F.P.T. Ice Making Water Inlet
 - (C) 1.27cm M.P.T. Ice Making Water Drain
- Water-Cooled Unit Option:**
 - (D) 0.95cm F.P.T. Condenser Inlet
 - (E) 1.27cm M.P.T. Condenser Drain
 - (F) 0.95cm M.P.T. Ice Making Water Drain
 - (G) 0.95cm F.P.T. Ice Making Water Inlet
 - (H) 1.9cm F.P.T. Bin Drain

Space Saving Designs



RNK-1100
D-570

Height	196.50 cm 77.36"
Width	76.20 cm 30.00"
Depth	86.30 cm 34.00"
Bin Storage	195 kgs 430 lbs.

Height includes adjustable bin legs 15.24 to 17.78cm, (6" to 7") set at 15.24 cm (6").

Air Flow Top View

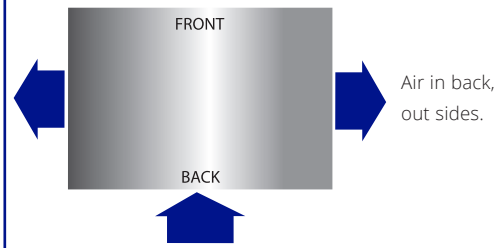

Specifications

	Model	Ice Shape	Ice Production 24 Hours		Power Usage kWh/45.4 kgs @ 32°Air/21°C Water 90°Air/70°F Water	Water Usage 45.4 kgs/100 lbs of Ice	
			21°Air/10°C Water 70°Air/ 50°F Water	32°Air/21°C Water 90°Air/ 70°F Water		Potable Water	Condenser Water
AIR-COOLED	RNK-1100A	Nugget	410 kgs	283 kgs	5.01	45.4 L	n/a
			904 lbs	626 lbs		12 gal	n/a
Water-COOLED	RNK-1100W	Nugget	525 kgs	435 kgs	4.04	45.4 L	496 L
			1,158 lbs	960 lbs		12 gal	131gal

Shipping Weight 113kg / 249lbs

Welbilt reserves the right to make changes to the design or specifications without prior notice.

www.manitowocice.com

Welbilt Deutschland GmbH
Auf der Weih 11
D - 35745 Herborn,
Germany
Tel.: +49 27 72 58 050
welbilt.com.de

Welbilt Iberia, S.A.U
Textil, 6 - Pol.Ind. La Ferreria
- 08110 Montcada i Reixac
Barcelona, Spain
Tel.: +34 902 20 10 69
welbilt.com.es

Welbilt UK
Ashbourne House, The Guildway,
Old Portsmouth Rd, Guildford
GU3 1LR, United Kingdom
Tel.: +44 1483 464900
www.welbilt.uk

