

BISON

REFRIGERATION

Units Manufactured Prior 10-1-18

Include 1 Year Parts + Labor / 5 Year Compressor Warranty

Units Manufactured After 10-1-18

Include 2 Year Parts + Labor / 5 Year Compressor Warranty

BST-48-18 2 Door Mega Top Sandwich Unit

Dimensions

Exterior Dimensions (Inches)	48.25" x 34" x 47.25"
Interior Dimensions Top (Inches)	42.5" x 21.5" x 8.5"
Interior Dimensions Bottom (Inches)	43" x 19.5" x 20"
Packaging Dimensions (Inches)	51" x 37.5" x 48.2"
Capacity (cu. ft.)	14.7 cu. ft.
Gross Weight (lbs)	265 lbs

Construction

Exterior Material	430 series stainless steel
Interior Material	430 series stainless steel
Insulation Material	Polyurethane
Insulation Thickness (mm)	45
# of Doors	2
# of Shelves	2
Shelf Material	Plastic coated steel
Shelf Load Capacity (lbs/pc)	155 lbs

*Does not include pans

Cooling

Temperature Range	33° ~ 40° F
Refrigerant	R290
Refrigerant Amount (oz)	12.3
Maximum Ambient Temperature Rating	90° F
Defrost Method	Air Defrost
Defrost Power (W)	0
Cooling Method	Ventilated
Temperature Controller	Thermostat
Compressor H/P	1/3

Electrical

Voltage (v/Hz)	115/60
Power (W)	560
Power Consumption (kw/24hr)	2.2
Phase	1

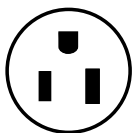
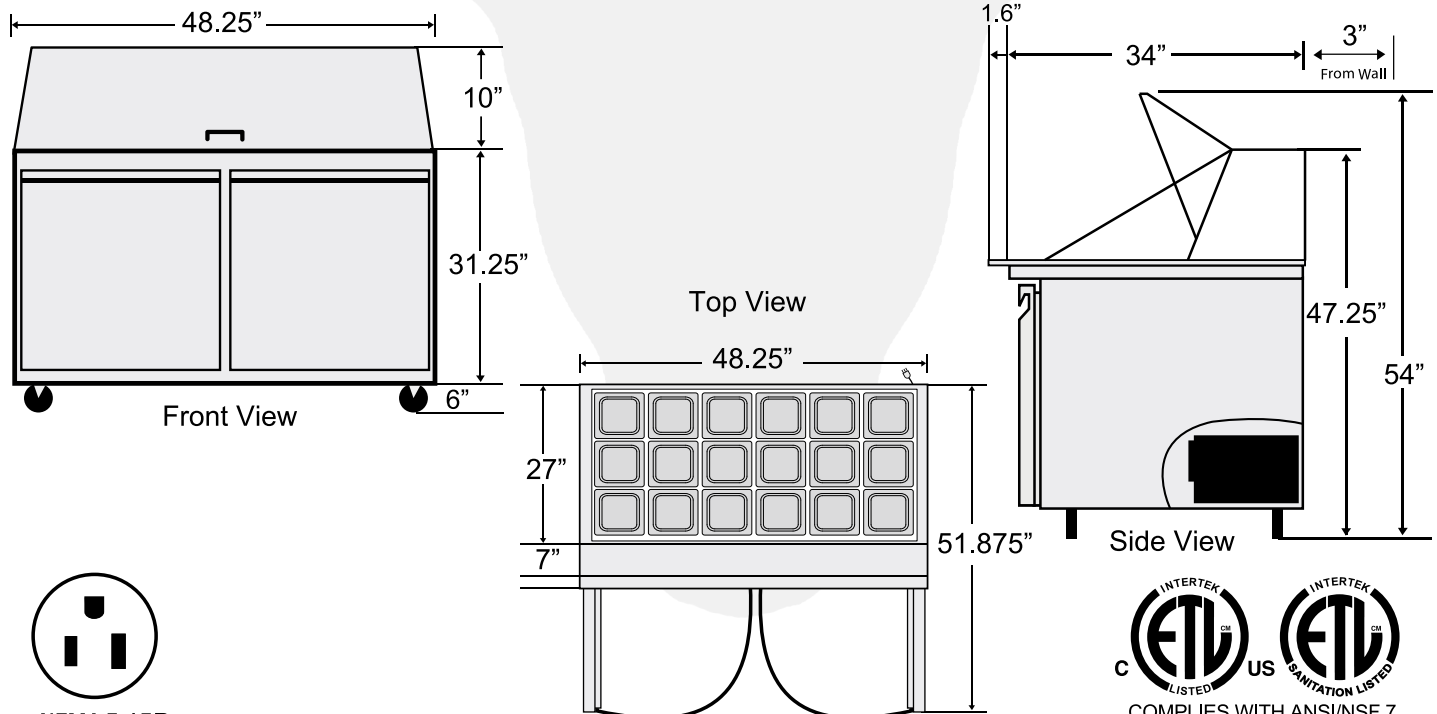

NEMA 5-15P



COMPLIES WITH ANSI/NSF 7 FOR FOOD SERVICE