



Profit from the Eagle Advantage®

Specification Sheet

Short Form Specifications

Eagle Tank Rack, Style "A", model _____. Unit includes one chrome-plated dunnage mat with frame, four 33" chrome-plated posts, one chrome-plated 3-sided frame, and cable assembly. Shipped knocked down.

Eagle Tank Rack Style "B", model _____. Unit includes one chrome-plated dunnage mat with frame, four 74" chrome-plated posts, two chrome-plated wire shelves with patented QuadTruss® design, one chrome-plated 3-sided frame, and cable assembly. Shipped knocked down.



style "A" tank rack with optional drip pan shown



style "B" tank rack with optional drip pan shown

Options / Accessories

- Cylinder retainer
- Drip pan

EAGLE GROUP

100 Industrial Boulevard, Clayton, DE 19938-8903 USA
 Phone: 302-653-3000 • 800-441-8440 • Fax: 302-653-2065
www.eaglegrp.com
www.eaglegrpnews.com
www.eaglemhc.com

For custom configuration or fabrication needs, contact our **SpecFAB® Division**.
 Phone: 302-653-3000 • Fax: 302-653-2065 • e-mail: quotes@eaglegrp.com

Item No.: _____
 Project No.: _____
 S.I.S. No.: _____

Tank Racks

MODELS:

- STR2430A
- STR2448A
- STR2430B
- STR2448B
- DP30
- DP48
- CRR24-C

Style "A" Racks

- One dunnage mat with frame.
- One 3-sided frame.
- Four 33" (838mm) posts.
- One cable assembly.
- Shipped knocked-down.
- Chrome-plated.

Style "B" Racks

- One dunnage mat with frame.
- One 3-sided frame.
- Four 74" (1880mm) posts.
- One cable assembly.
- Two standard shelves.
- Shipped knocked-down.
- Chrome-plated.

Optional Cylinder Retainer

- Chrome-plated.
- Cylinders are secured to retainer to further prevent damage.

Optional Drip Pans

- Stainless steel.
- Brackets included.

Certifications / Approvals



AutoQuotes



EG01.31 Rev. 02/23

Spec sheets available for viewing, printing or downloading from our online literature library at our websites

Eagle Foodservice Equipment, Eagle MHC, and SpecFAB® are divisions of Eagle Group. ©2023 by the Eagle Group



Item No.: _____
 Project No.: _____
 S.I.S. No.: _____

Tank Racks

Style "A" Tank Racks

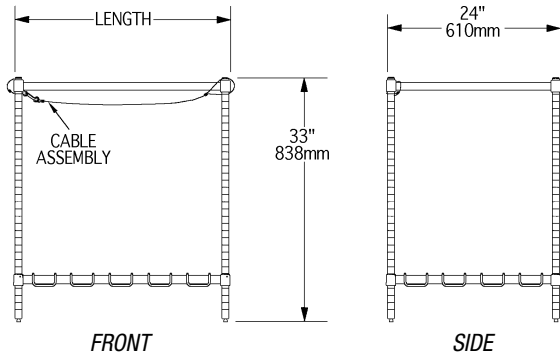

Style "B" Tank Racks

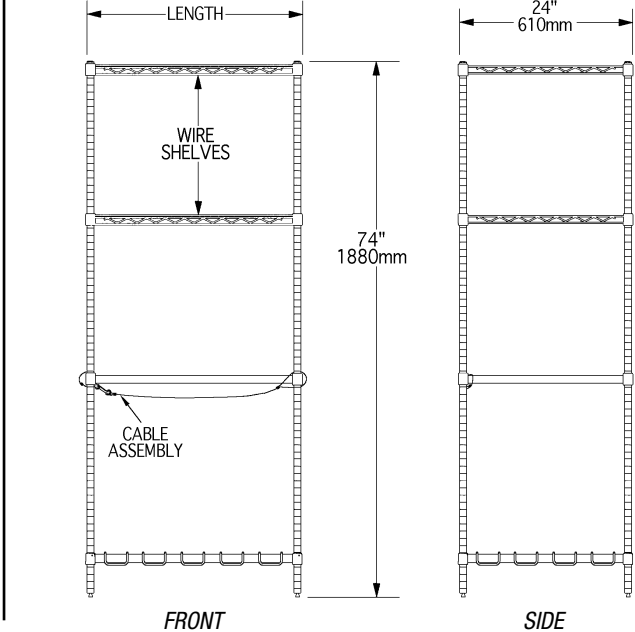

Style "A" Tank Racks

Style "B" Tank Racks

model #	height		weight		model #	height		weight		width		length	
	in.	mm	lbs.	kg		in.	mm	lbs.	kg	in.	mm	in.	mm
STR2430A	33"	838	40	18.1	STR2430B	74"	1880	68	30.8	24"	610	30"	762
STR2448A	33"	838	50	22.7	STR2448B	74"	1880	88	39.9	24"	610	48"	1219

Optional Drip Pans

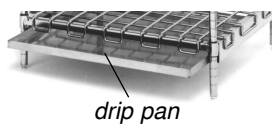

model #	width		length		weight	
	in.	mm	in.	mm	lbs.	kg
DP30	24"	610	30"	762	8	3.6
DP48	24"	610	48"	1219	12	5.4

Optional Cylinder Retainer



model #	width		weight	
	in.	mm	lbs.	kg
CRR24-C	24"	610	7	3.2

EAGLE GROUP

100 Industrial Boulevard, Clayton, DE 19938-8903 USA

Phone: 302-653-3000 or 800-441-8440 • Fax: 302-653-2065

www.eaglegrp.com • www.eaglegrpnews.com • www.eaglehmc.com

Printed in U.S.A.
 ©2023 by Eagle Group

Rev. 02/23

Spec sheets available for viewing, printing or downloading from our online literature library at our websites

Although every attempt has been made to ensure the accuracy of the information provided, we cannot be held responsible for typographical or printing errors. Information and specifications are subject to change without notice. Please confirm at time of order.