

INSTRUCTION FOR USE AND CARE OF FLOOR RACK SYSTEM

PRODUCT NUMBER N2710

The *Floor Rack System* is designed for use in food preparation, serving and dry storage areas, or cooking and warewashing areas with occasional spillage.

ASSEMBLY: Place a 12" x 12" unit on the floor with cylindrical feet down. Holding a second unit above the first, align the two projecting cylindrical feet with two larger cylindrical holes in the first unit. Lower the unit until the two feet are seated in the corresponding holes and press firmly (see *Figure 1*). Strike the projecting feet with a rubber or wooden mallet if necessary to ensure that the units are fully seated (see *Figure 2*). Top surfaces of sections must be flush.

Proceed as above with successive units, keeping in mind placement of the sides with projecting feet.

NOTE: Units may be trimmed to fit using a hand or power saw (see *Figure 3*). **WARNING:** Wear safety glasses when cutting this material.

DISASSEMBLY: Reverse above procedure to disassemble the sections. It may be necessary to elevate the male unit with a spacer block while tapping lightly on the corresponding female unit.

CLEANING INSTRUCTIONS: Large sections should be disassembled for ease of cleaning. All purpose detergent cleaner is acceptable. Use with brush, cloth or power spray washer (160°F maximum).

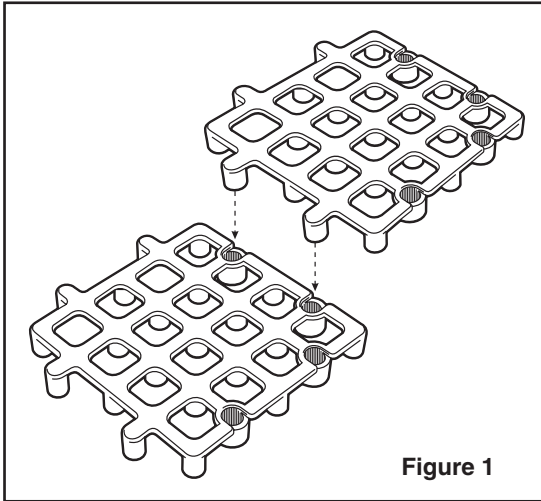

Figure 1

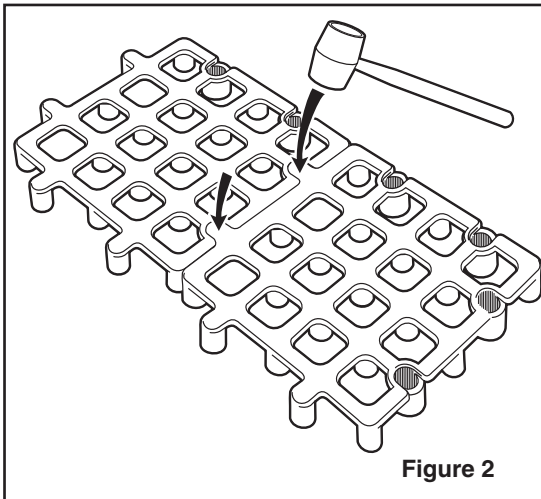

Figure 2

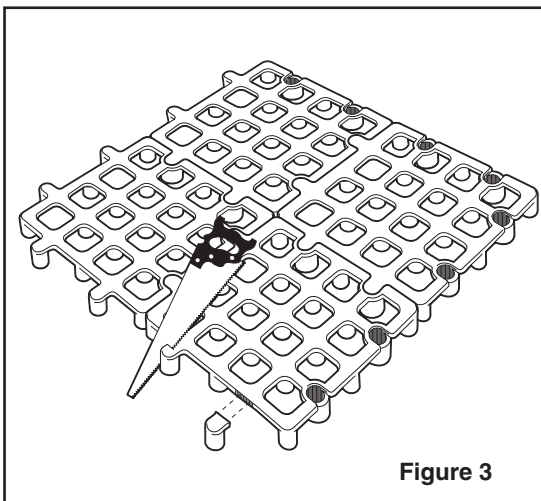

Figure 3

Worldwide Headquarters:
P.O. Box 53006
Oklahoma City, Oklahoma 73152-3006
(405) 475-5600 • FAX (405) 475-5607
1-800-654-8210
#104803860 Rev. 7/02

European Distribution Center:
Edisonstraat 84, P.O. Box 110
6900 AC Zevenaar, The Netherlands
Tel +31/(0)316-596550 • Telex 45642
FAX +31/(0)316-340168

CARLISLE
FoodService Products