

### Special Features:

- ✓ Durable Aluminum Construction
- ✓ 10-20 Full Size Sheet Pan Capacity
- ✓ 20-40 Half Size Sheet Pan Capacity
- ✓ 250lb - 400lb Weight Capacity
- ✓ Includes 2 Locking and 2 Standard Casters
- ✓ 3" Pan Spacing
- ✓ Half & Full Size Racks Available
- ✓ Side & End Load Full Size Racks Available

### About Empura Bun Pan Racks:

Empura bun pan racks are an economical option for updating or expanding your baking prep and cooling areas. With their durable aluminum construction, sturdy shelf rails, locking casters, 1-inch thick side rails, and high pan and weight capacity, these bun pan racks are indispensable in the kitchen. They provide reliable stability and support for any task, ensuring your staff can work efficiently and effectively.

### TECHNICAL SPECS

Model #	E-RACKECO20A	E-RACKECO20ASL	E-RACKECO10A
Overall Width	20-3/16"	18-1/8"	20-3/16"
Overall Depth	26"	28"	26"
Overall Height	69-3/8"	69-3/8"	38-1/4"
Pan Rail Width	1-1/2"	1-1/2"	1-1/2"
Pan Rail Guard Height	1"	1"	1"
Full / Half Pan Capacity	20 / 40	20 / 40	10 / 20
Weight Capacity	350lb	400lb	250lb
Individual Shelf Capacity	55lb	55lb	55lb
Caster Type	Swivel Casters	Swivel Casters	Swivel Casters
Number of Casters	2 Locking / 2 Standard (4 Total)	2 Locking / 2 Standard (4 Total)	2 Locking / 2 Standard (4 Total)
Caster Height	6"	6"	6"
Caster Wheel Diameter	5"	5"	5"
Caster Wheel Material	Polypropylene	Polypropylene	Polypropylene
Construction Material	Aluminum	Aluminum	Aluminum
Rack Type / Style	Open / Full Height	Open / Full Height	Open / Half Height
Pan Shelf Spacing	3"	3"	3"
Loading Method	End Load	Side Load	End Load
Freezer / Refrigerator	Safe	Safe	Safe
Unit Weight	27lb.	23.1lb.	17.4lb.
Shipping Weight	29.80lb.	27lb.	19.4lb.

## E-RACKECO20A

Front View

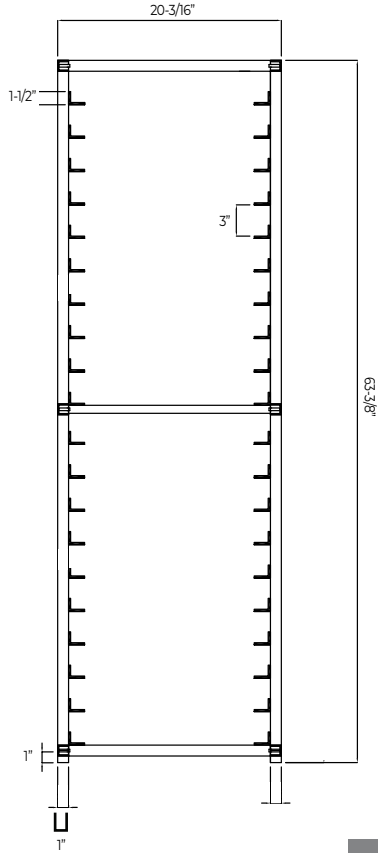

Side View

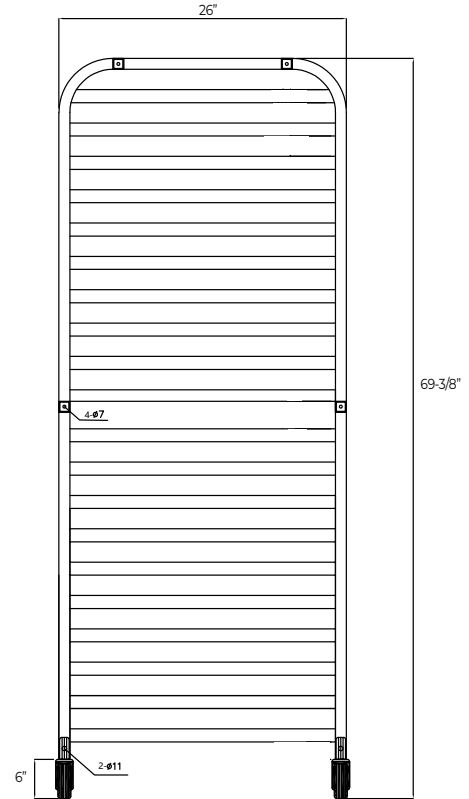

Bottom View

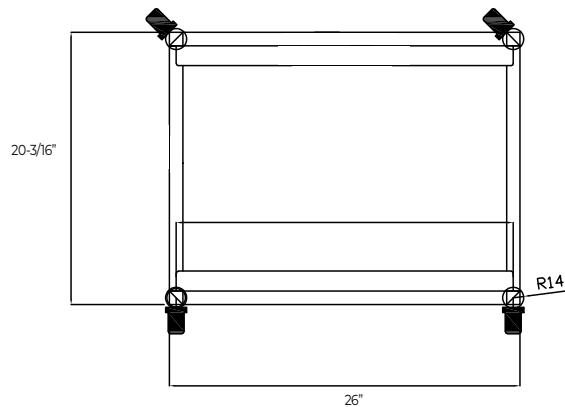

**Intended For Commercial Use Only.** Empura assumes no liability for component failure, factory defects or any other damages for units installed in non-commercial foodservice or residential applications.

**Attention CA Residents:** This product can expose you to chemicals including lead, which are known to the State of California to cause cancer, birth defects, or other reproductive harm. For more information, go to [www.p65warnings.ca.gov](http://www.p65warnings.ca.gov).

## E-RACKECO20SA

Front View

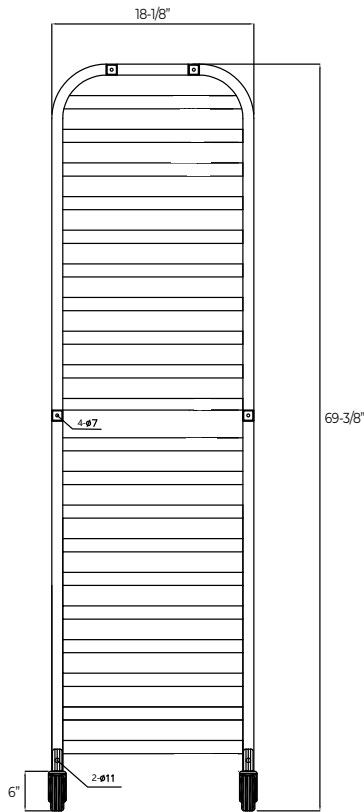

Side View

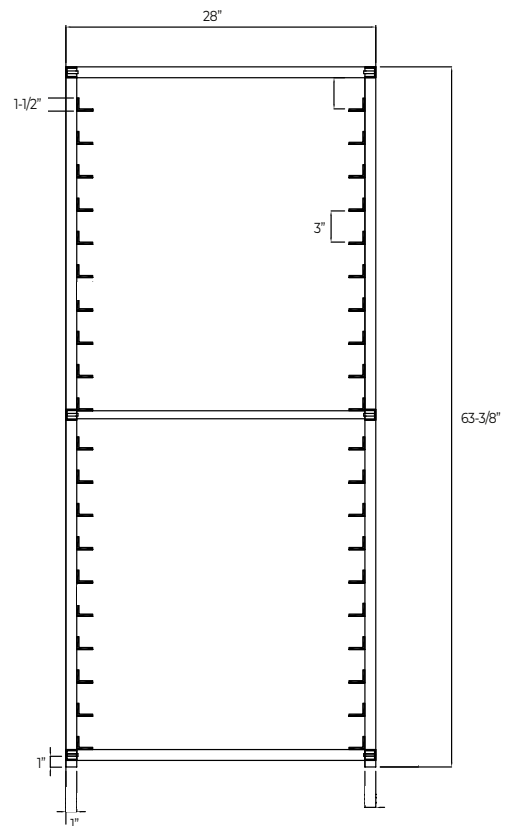

Bottom View

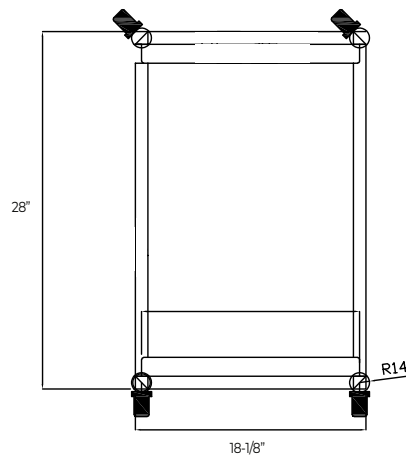

**Intended For Commercial Use Only.** Empura assumes no liability for component failure, factory defects or any other damages for units installed in non-commercial foodservice or residential applications.

**Attention CA Residents:** This product can expose you to chemicals including lead, which are known to the State of California to cause cancer, birth defects, or other reproductive harm. For more information, go to [www.p65warnings.ca.gov](http://www.p65warnings.ca.gov).

## E-RACKECO10A

Front View

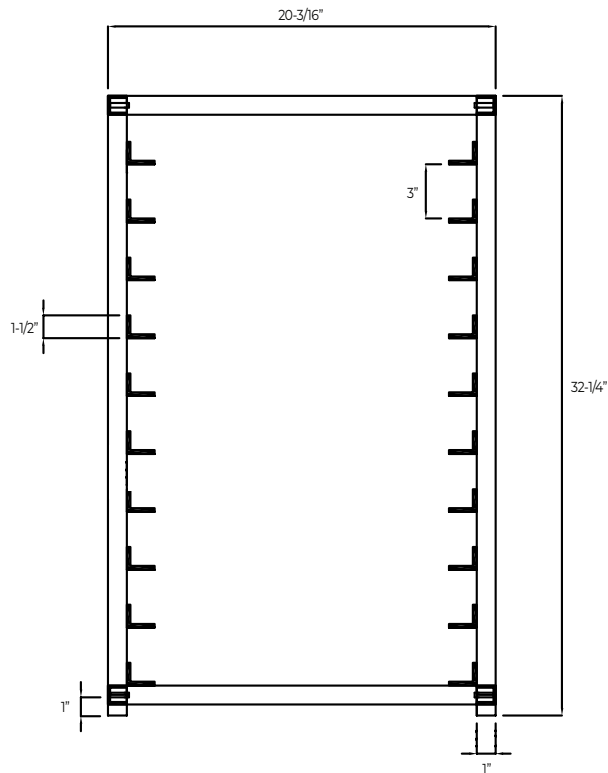

Side View

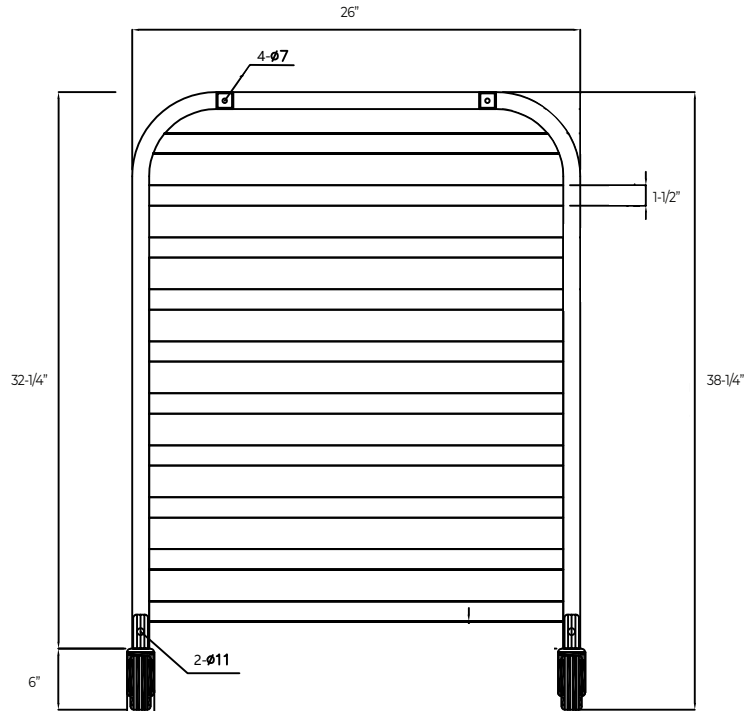

Top View

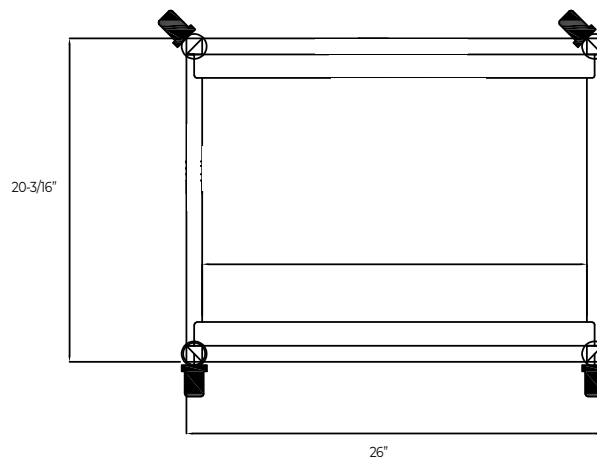

**Intended For Commercial Use Only.** Empura assumes no liability for component failure, factory defects or any other damages for units installed in non-commercial foodservice or residential applications.

**Attention CA Residents:** This product can expose you to chemicals including lead, which are known to the State of California to cause cancer, birth defects, or other reproductive harm. For more information, go to [www.p65warnings.ca.gov](http://www.p65warnings.ca.gov).