



Project _____
 AIA # _____ SIS # _____
 Item # _____ Quantity _____ C.S.I. Section 114000

VBP18ES-CBFT

Correctional Holding & Transport Cabinets



Model VBP18ES - CBFT



SPECIFIER STATEMENT

Vulcan Model No. VBP18ES-CBFT correctional heated holding and transport cabinets. Blower motor for gentle and even temperature distribution. Complete with 5" heavy duty casters (2 swivel with brakes and 2 rigid) Electronic control with digital display for holding at temperatures up to 200°F with security cover. Welded racking will hold a variety of pan sizes on shelves with heights of either 4" or 6". 14-gauge Transport Latch included. Cabinet interior and exterior are both constructed out of 20 gauge stainless steel. Recessed and welded side-mounted handles, magnetic action door latch, and full insulation; 1½" in side walls and 2" in top. Integrated steel frame for maximum strength. Complete with rear mounted cord and plug: NEMA 5-15 for 120 volts with strain relief. Built with tamper-resistant fasteners. One-year limited parts and labor warranty. After the first year, 10-year parts warranty on the heating elements.

UL Listed. UL Listed to Canadian safety standards. Classified by UL to NSF Standard #4.

MODELS

- VBP18ES-CBFT** (12 Shelves - 4" spacing)
- VBP18ES-CBFT-6** (8 Shelves - 6" spacing)

STANDARD FEATURES

- Holding Capacity:
 - 18" x 26" sheet pans
 - 12" x 20" x 4" pans, or a combination of both
- 12 total tray shelves with fully welded removable tray slides — 4" spacing (VBP18ES-CBFT)
- 8 total tray shelves with fully welded removable tray slides — 6" spacing (VBP18ES-CBFT-6)
- Electronic control with digital display for holding at temperatures up to 200°F with lockable security cover and viewport
- Blower motor for gentle and even temperature distribution
- Solid door with solid hinges
- 5" heavy duty casters (2 swivel with brakes and 2 rigid)
- Recessed and welded side mounted handles
- 20-gauge stainless steel interior and exterior
- Fully insulated with 1½" in side walls and 2" in top
- Magnetic action door latch
- Rear mounted cord (NEMA 5-15 for 120 volts) with strain relief
- 14-gauge lockable transport latch
- Tamper-resistant fasteners throughout
- Full perimeter bumper
- One-year limited parts and labor warranty; after the first year, 10-year parts warranty on the heating elements
- ENERGY STAR® certified

VBP18ES-CBFT – Correctional Holding & Transport Cabinets

Approved by _____ Date _____ Approved by _____ Date _____

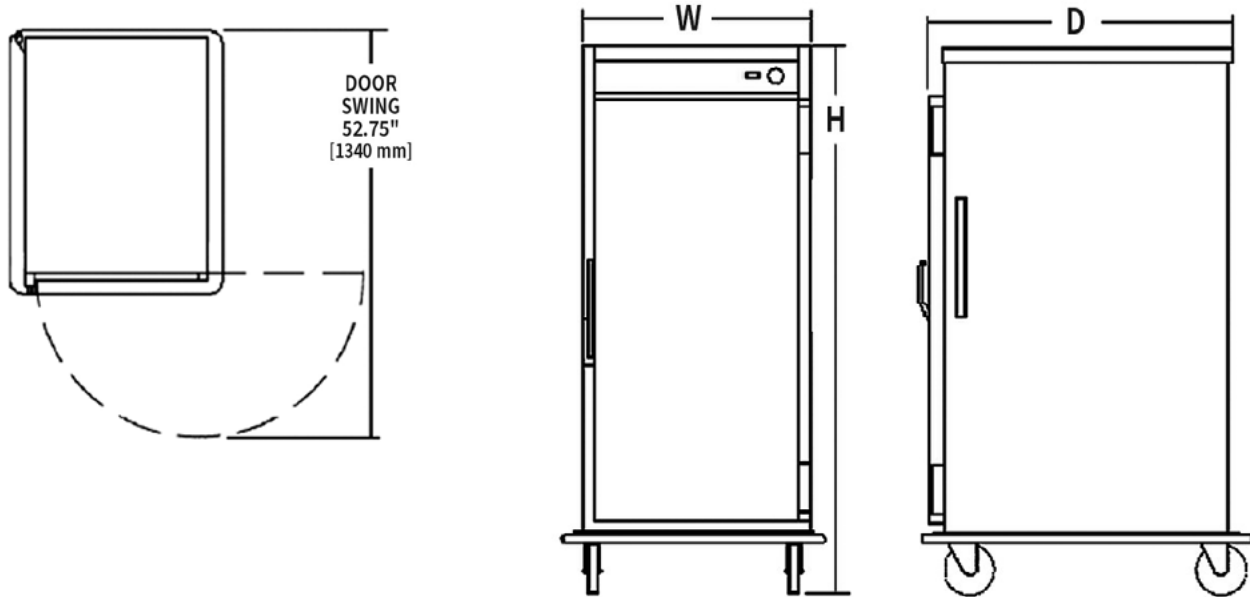

| Model | Exterior Dimensions (includes bumper) | Capacity | Electrical | | | Shipping Weights |
|-----------------------|--|------------------------------------|------------|-------|------|------------------|
| | | | Volts | Watts | Amps | |
| VBP18ES-CBFT | 32" W x 36" D x 70" H | 12 Sheet Pans 24 Steam (4" Deep) | 120 | 1,500 | 12.5 | 400 lbs / 182 Kg |
| VBP18ES-CBFT-6 | 32" W x 36" D x 70" H | 8 Sheet Pans 16 Steam (6" Deep) | 120 | 1,500 | 12.5 | 395 lbs / 180 Kg |

This appliance is manufactured for commercial use only and is not intended for home use.