



**Model
7.7GBS-EXT**



Standard Features

- 42 to 56 bird capacity (3 1/2 to 4 lb +)
- Rear wall of flame for full merchandising of product
- Front pivot glass doors for full view of product
- Double rotation for genuine rotisserie cooking (Drums and spits rotate)
- Dual cooking chambers have separate cooking controls to allow different temperatures and products
- Allows combination of spits and rotating baskets to be cooked simultaneously
- Foot pedal allows stopping of the motor for easy loading and unloading
- Water drip trays for humidified cooking
- Front lighting enhances the appeal of cooked product
- Pull out loading & unloading drawers

GAS-FIRED



Options

- 8 Position drum 48-64 for smaller birds (3lb or less)
- Water bath option
- Pass thru option
- Angle spits to replace regular spits
- Thermowave spits
- Custom color available
- Available in all Stainless Steel (N/7.7G-EXT)

Model 7.7GBS-EXT

Technical Data		Model 7.7GBS-EXT
Cooking Type	Batch	
Gas Type	Natural or LP	
Supply Voltage / Amp	120V, 60hz, 5A	
Lights • Wattage Each • Total Lighting Wattage	2 • 90 • 180	
Gear Motor Hp	1/25	
Total BTU's Natural • Propane	180,000 • 180,000	
BTU's/Burner Natural Gas • # of Burners	40,000 • 4	
BTU's/Burner Propane Gas • # of Burners	40,000 • 4	
Back Show Burner	20,000	
Nominal Gas Pressure In WC" Natural • Propane	5 1/2" • 11"	
Gas Connection (male end required)	1"	
Net Weight	1000	
Dimensions		
	A	35"
	B	27 1/8"
	C	56"
	D	85"
	E	28 11/16"
	F	44 3/4"
	G	5"
	H	30 1/4"
	I	4 5/8"
Spits • Distance Between Spits	14 • 7 1/8"	
Chicken Capacity	42 – 56	
Clearance From Side Walls	3"	
Clearance From Rear Wall With Steel Back	3"	
Clearance Off Rear Walls With Glass Back	15"	

Ventilation

Gas units must be vented under a hood.

Drive Mechanism

A sprocket gear attached to gear motor drives a chain, which in turn drives a large sprocket gear on the central drive shaft. The drive wheel has individual drive gears which operate in a planetary action around a stationary gear. A center slave wheel allows for the use of short spits and dual batch production at one time.

Installation Requirements

Licensed electrician, licensed gas fitter for all gas connections and checkout. HVAC specialist for air evacuation. Placement of this machine is critical since it is hot. Plan carefully.

Front Facings

Machine is made with high grade polished stainless. No screw fittings appear on the front facing. For an additional charge, facing can be powder coated to desired color.

Service, Maintenance, and Construction

Full side service panels allow easy access to all working parts. The 7.7 is easily cleaned from front to back, enabling the user to meet all sanitary and hygienic requirements with a minimum of time and effort. The interior cooking area is constructed completely of high-grade stainless steel. Insulation is complete on all top and side panels. Rigid box design insures strength.

Safety

Pivot glass doors provide full access to baskets and spits. Electrical components are located behind the control panel in an area fully insulated from the interior cooking space. Control panel information, with clear, legible graphics, eliminates confusion for even the novice operator.

**Specifications are subject to change without notice. When ordering please specify voltage, phase, and frequency requirements.*

Model 7.7GBS-EXT

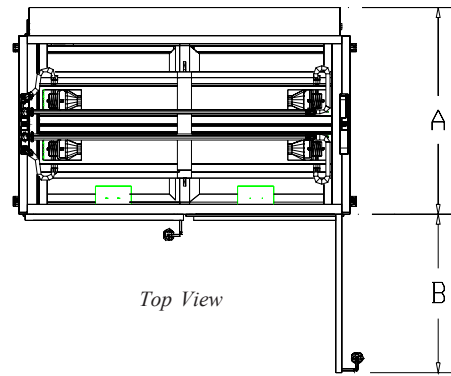

Top View

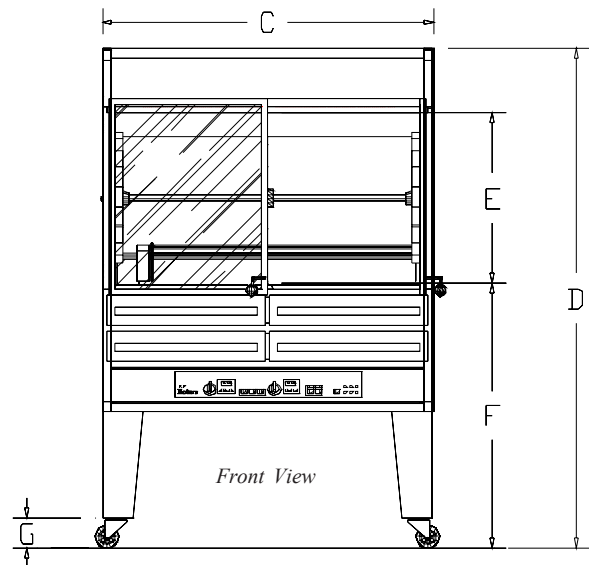

Front View

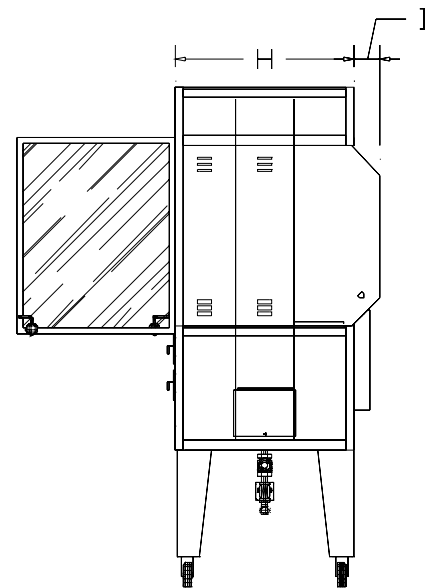

Side View



an ISO 9001:2000 certified company
Hickory Industries, Inc. • 4900 Westside Avenue • North Bergen, NJ 07047
201-223-0050 • Fax: 201-223-0950
www.hickorybbq.com • e-mail: hickorybbqs@aol.com