

DRAWERED SANDWICH PREP. TABLE BACK MOUNTED CONDENSING UNIT

Project Name: _____

Project Location: _____

Model #: _____ Quantity: _____

Available Warehouse: _____

EPB Series Model: EPBNR2-D4



Refrigeration System

- Back mounted, self-contained and fully detachable Blizzard R290 condensing unit uses environmentally friendly, EPA-compliant R290 refrigerant with zero (0) Ozone Depletion Potential (ODP) and three (3) Global Warming Potential (GWP). Blizzard R290 is easily replaceable and requires no on-site brazing.
- Front air breathing for flexibility in installation.
- Electronically commutated (ECM) fan motors achieve rapid cooling with less energy consumption.
- Full-length air duct system ensures optimal circulation of cold air.
- Time-initiated and temperature-terminated auto defrost cycle for seamless operation.
- Large capacity, corrosion-resistant condenser and evaporator coils.
- Self-maintaining, energy-efficient condensate drain pan requires no external drains or electric heaters.
- High performance, auto-reverse condenser fan motor supports compressor ventilation and condenser coil cleaning. Refer to owner's manual for full maintenance instructions.
- Pressure relief devices allow smooth access to cabinet interior when re-opening doors.
- Pre-wired and ready to plug, 115V/60Hz/1Ph, NEMA 5-15P.

Cabinet Construction

- Heavy duty stainless steel interior / exterior with rounded corners for a hazard-free workspace.
- Open spaced interior with no walls between cabinet compartments. Vented stainless steel panel between top pan area and cabinet catches food debris.
- 16 gauge, high quality stainless steel worktop, lid and hood.
- Galvanized steel bottom and rear.
- 2.5" thick high density polyurethane insulation.
- Four 5" swivel casters with locks on front set.

Doors

- Heavy-duty stainless steel interior/exterior.
- 2.5" thick high-density polyurethane insulation.
- Snap-in magnetic gaskets for ease of cleaning.
- High strength, recessed handles
- Thick gauge, stainless steel drawer frames with low-friction ball bearings.
- Drawer pans not included. See table for drawer pan capacity.

Preparation Area

- NSF certified polycarbonate 6" deep pans (see table for size and quantity).
- 1/2" thick, foam insulated lid keeps top pan area cold and prevents moisture build-up.
- 12 1/4" deep cutting board is removable for ease of cleaning.

Shelving

- Height adjustable stainless steel clips.

Temperature Control

- Multi-function digital controller with easy to read LED display.
- Factory preset temperature, 35°F. Temperature setting range from 33°F to 54°F.
- Audible overheat protection alarm for compressor and condenser coil.

Options

- NSF certified stainless steel double overshelf.
- Additional shelving.
- 3" swivel casters with locks.
- 3.5" – 6" height-adjustable and interchangeable legs.



Please visit our website for updated Energy Efficiency information

Ref/ Frz/Dual	Doors	Capacity			Shelves	Refrigerant	HP	Power V-Hz-Ph	Amps	Crated Weight	Exterior Dimensions		
		Cu. Ft.	# Top Pans	# Drawer Pans							L	D	H*
REF	4(DR)	13	1/6x12	1/2x4, 1/3x4, 1/4x2, 1/6x2*	-	R-290	1/4+	115-60-1	3.5	368 lbs (167kg)	47.5" (1207mm)	31.5" (800mm)	38.5" (978mm)

(†) Based on evaporating temperature of 23°F (-5°C) & condensing temperature of 131°F (55°C). (►) Product capacity is calculated based on standard industry figures. (✳) Reference plan view for clarification on caster/unit height. If dimensions and capacity are critical, please contact Everest Refrigeration. Blizzard R290 replacement is at the sole discretion of Everest Refrigeration. Specifications subject to change without notice.

DRAWERED SANDWICH PREP. TABLE

BACK MOUNTED CONDENSING UNIT

EPB Series Model: EPBNR2-D4

DIMENSIONAL DATA

External Dimensions	L	47.5" (1207mm)
	D	31.5" (800mm)
	H*	38.5" (978mm)
Crated Weight		368 lbs. (167kg)
Doors/Drawers/Lids		4(DR)
Max Weight Support (LBS)		-

STORAGE DATA

Net Capacity Cu. Ft. ▶	13
Shelves	-
Barrels	-
20 oz. Bottles	-
12 oz. Bottles	-
12 oz. Cans	-
8" Mugs	-
# of Pans (Top)	1/6x12
# of Pans (Drawer)	1/2x4, 1/3x4, 1/4x2, 1/6x2*
Dividers	-
Trays	-

ELECTRICAL DATA

Voltage	115-60-1
Full Load Amperage	3.5A
Feed Wires with Ground	3
Cord Length	9ft
NEMA Plug Type	 NEMA 5-15P

REFRIGERATION DATA

Compressor Mounting	Back
Refrigerant	R-290
Compressor HP	1/4+
BTU/HR †	N/A

KEY

D	Door	R	Refrigerator
L	Lid	REF	Refrigerator
H	Half Door	F	Freezer
FD	Full Door	FRZ	Freezer
SD	Solid Door	DUAL	REF/FRZ Combo
GD	Glass Door	DR	Drawer

	Elevation	Right	Plan	3D	Back

PLAN VIEW

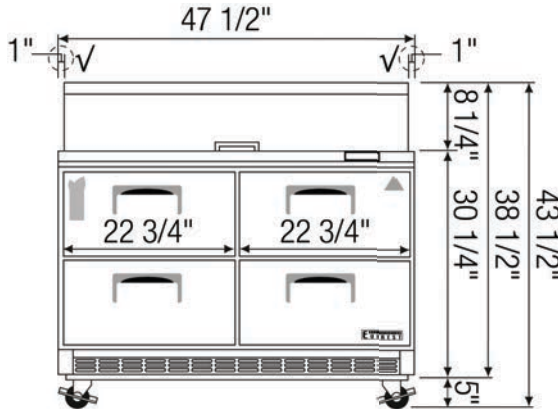

FRONT

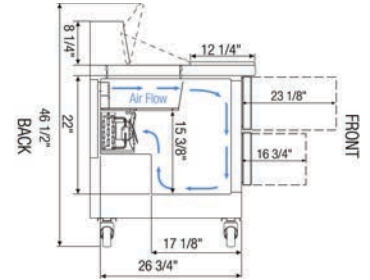

SIDE

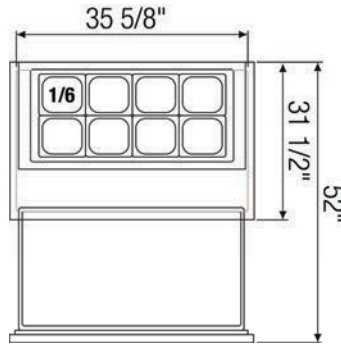

TOP

ACCESSORIES & OPTIONS

Part Number	Description
AJL03-00	Interchangeable Leg for Caster (Optional)
CASA3-01	3" Overall Height Caster Assembly - (2) Front (2) Rear
OS22-00	Double overshelf (47" L x 13.5" D x 48" H). Adds 31" of height to unit.

* Drawer pans not included

(†) Based on evaporating temperature of 23°F (-5°C) & condensing temperature of 131°F (55°C). (▶) Product capacity is calculated based on standard industry figures. (✳) Reference plan view for clarification on caster/unit height. If dimensions and capacity are critical, please contact Everest Refrigeration. Blizzard R290 replacement is at the sole discretion of Everest Refrigeration. Specifications subject to change without notice.