

PRODUCT METERING FILLING STATION

Project _____
 Item _____
 Quantity _____
 FCSI Section 11400 _____
 Approved _____
 Date _____

Model

- MFS



Unit shown with optional casing clipper

Standard Features

- Air operated Piston Pump with volume adjustment from 20 to 128 oz. per stroke
- Adjustable speed control in both directions
- Air operated product dispensing valve assures accurate portion control
- Cabinet with hinged doors, permitting full access for cleaning and service.
- Cabinet top with sink and lift-off grid
- Two 8" wheels and two 5" locking swivel casters with brakes for stability during pumping
- Narrow design - only 24" wide for easy mobility and storage
- Mounting bridge for clipper and label dispenser
- Two (2) - 3-foot long sections of 3" diameter food hose
- Removable receptacles for casings
- One eight (8) foot-long flushing hose for easy clean-up
- Spare parts kit (gaskets, wrenches, etc.)
- Brush set for easy cleaning
- Accepted for use in USDA inspected facilities

Short Form Specifications

Shall be CLEVELAND Model: MFS-__: Product Metering Filling Station with; selector switch for single stroke and continuous operation; air operated positive displacement piston style pump with adjustable speed controls and stroke from 20 to 128 oz; air controlled product dispensing valve; cabinet with hinged doors, sink with drain and lift-off wire grid for easy clean-up. Unit comes with two 3 foot long food hoses, label dispenser, spare part kit and cleaning brush set.

Options & Accessories

- Casing Clipper
- Label Printer
- Ring stand for hand filling
- Spare product hose with fittings (specify length)
- Pan Filler Assembly
- Extra 3" food hoses (specify length and male/female ends)
- 3" x 90° stainless steel elbow

KE004046-129 A

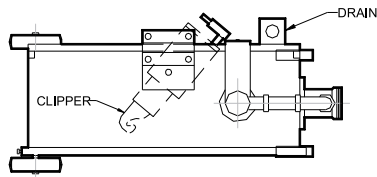

TOP VIEW

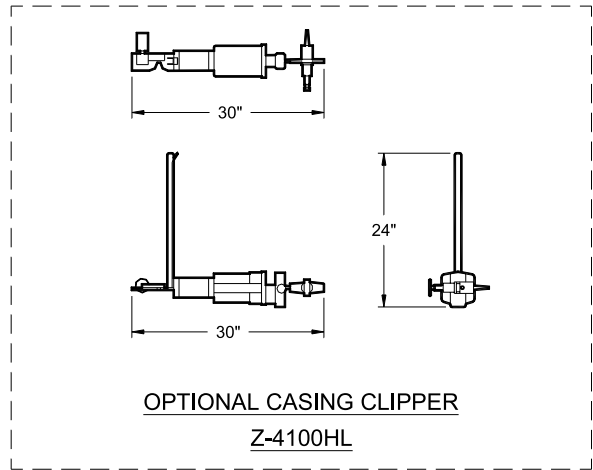

OPTIONAL CASING CLIPPER
Z-4100HL

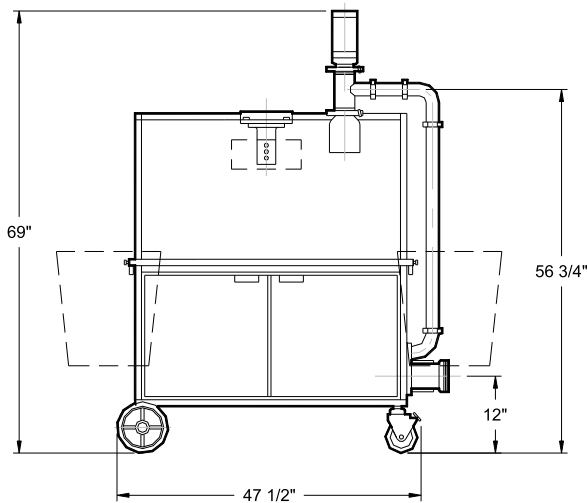

FRONT VIEW

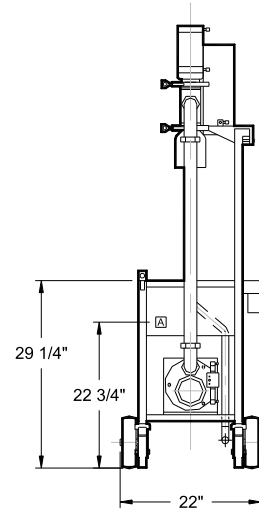

SIDE VIEW

MODEL	AIR	ELECTRICAL	SHIPPING WEIGHT (Approximate)
	A	⚡	
MFS (without Clipper)	15 CFM, 90 to 110 PSI	NONE	475 lbs
MFS (with Clipper)	25 CFM, 90 to 110 PSI	NONE	550 lbs

NOTE: AIR MUST BE DRY, CLEAN AND FREE OF OIL

Cleveland Range reserves right of design improvement or modification, as warranted.

(NOT TO SCALE)