

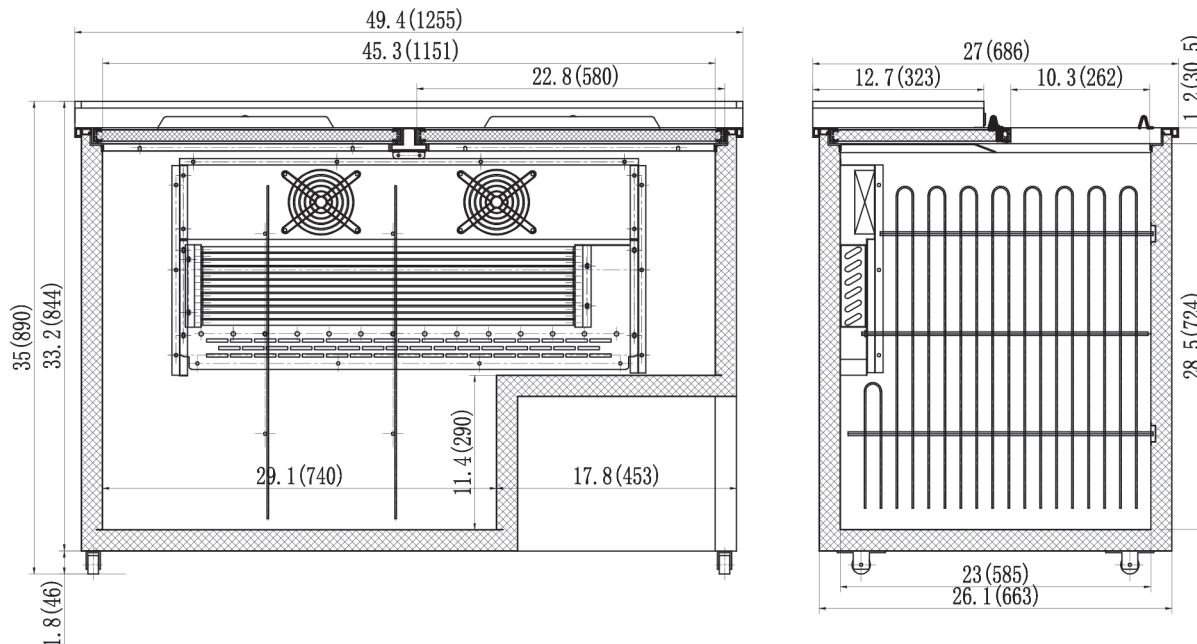

FEATURES

- CFC free refrigerant and foam insulation
- Electronic thermostat and digital LED temperature display for accurate control and easy reading
- Easy to mount 1" wheels are standard with all units
- Stainless steel framework construction
- Forced-air cooling
- Doors have lock and key
- Adjustable dividers included
- Self-defrosting evaporator
- Bottle cap opener & cap catcher standard
- Top: 430 stainless steel
- Interior: 304 stainless steel
- Exterior: Heavy duty, wear resistant black paint
- Temperature: 33 to 41°F / 0.5 to 5°C
- Electrical: 115/60/1 with NEMA 5-15P plug
- KBC-50 contains (cases) : 22.0 x 12 oz. cans or 18 x 12 oz. bottles

TECHNICAL DRAWINGS



Dimensions in inches (mm)

SPECIFICATIONS:

Model:	EMP-EKBC-50
Ext. Dimensions:	(W x D x H) 49.4" x 27" x 35"
Int. Dimensions:	(W x D x H) 29.1" x 23" x 28.5"
Doors	2
Amps:	7
Compressor Size (HP)	3/8
Shipping Weight:	309 lbs



Warranty: 24 months parts & labor. Additional 36 months on compressor (part only).

CERTIFIED TO ANSI/NSF-7 STANDARDS