



# 6795-C

## FROZEN BEVERAGE FREEZER

Two flavor, Floor, Gravity feed

### Powerful & Versatile

High capacity two flavor floor model for frozen beverage and milkshakes

#### Fast Freeze Down

Patented high efficiency heat exchanger allows fast freeze down with low energy consumption

#### Simple Control, Easy Operation

Simple and intuitive control system makes operation and viscosity adjustment easy, swift and more precise

#### Low Mix Indicator

Light turns "ON" at low mix to alert operator to add mix

#### See-through Dispensing Door

Clear dispensing door design makes product more attractive and serves as great marketing tool

#### Standby & Indicator

Maintains product temperature in both mix hopper and freezing cylinder below 4.4°C (40°F) overnight; Indicator lights up during Standby

Higher capacity solution with greater flexibility to serve larger crowds alcoholic & non-alcoholic frozen drinks including milkshakes



#### Hopper Agitators

Maintain product consistency and prevent product separation

#### Self-closing Dispensing Valves

Automatically prevents product overflow after dispense

#### Safety Protections

- High pressure switch to prevent compressor overheating
- Thermal overload to protect from motor overheating

#### Light Box (Optional)

- Illuminates flavor cards to attract more business
- Changes color to indicate Low Mix and Standby

#### One-hand Operated Spinner (Optional)

- Adds ability to blend and offer more varieties of treats
- Allows for multi-tasking one-hand operation that helps increase productivity and reduce serving time



# 6795-C

## FROZEN BEVERAGE FREEZER

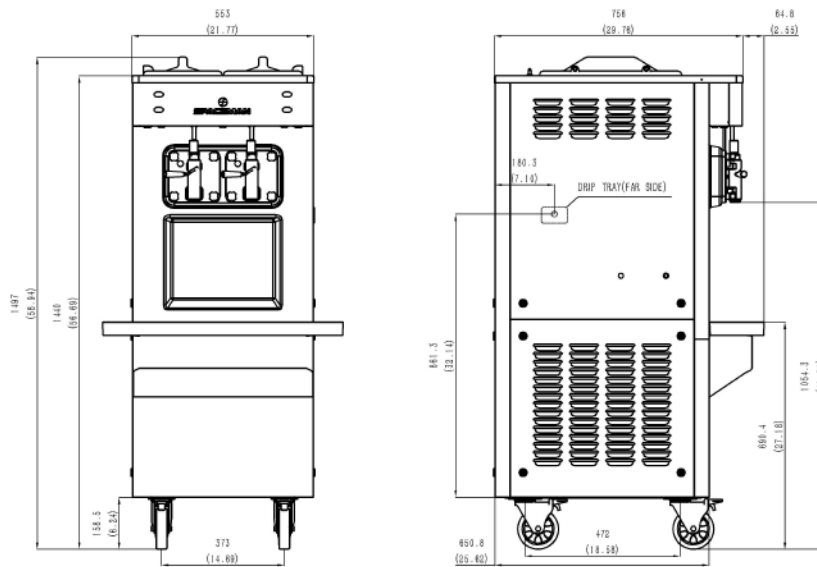

### SPECIFICATIONS

Flavors	2
Freezing Cylinders	2 x 6.9L / 7.3qt
Mix Hoppers	2 x 12L / 12.7qt
Output Capacity (8oz)	720 servings/hr
Clearance Requirements	152mm/6"

### Weight Kg/lb

Net	250 / 556
Shipping	270 / 600
Volume	1.12 CBM / 39.63 CBF

### Dimensions Net (mm/in) Shipping (mm/in)

Width	553 / 21.8	720 / 28.3
Depth	651 / 25.6	940 / 37.0
Height	1497 / 58.9	1660 / 65.4

### Electrical MFS MCA Power(kW)

220-240/50/1	30	21	3.6
208-230/60/1	30	24	4.0

### FEATURES

Control Systems	Two, Mechanical
Refrigerated Hoppers	✓
Hopper Agitators	✓
Standby Mode	✓
Auto Closing Dispensing Valves	✓
Low Mix Indicator Light	✓
Low Mix Indicator Alarm	✓
Standby Mode	✓
Standby Indicator Light	✓
High Pressure Protection	✓
Thermal Overload Protection	✓

### AVAILABLE OPTIONS

Top Air Discharge Chute	✓
Spinner	✓
Light Box	✓

• Above specifications are subject to change without notice