

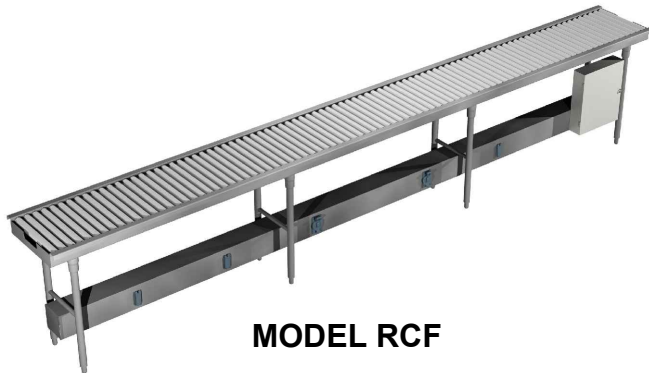

TRAY MAKE-UP CADDY-VEYOR NON-POWERED / RCF



MODEL RCF

FEATURES

- Heavy duty deluxe tray make-up Roller-veyor, will handle any type trays (flat bottom or irregular bottom). Non-mechanized, non-powered.

Specification:

Series RCF Roller tray make-up conveyor to be as manufactured by Caddy Corporation Unit shall be 19-1/4" wide x _____ long, and to accommodate trays up to 16" wide. (Specify dimensions of trays to be used.)

Conveyor bed to have a single row of full width 1-1/4" O.D. plastic rollers with stainless steel balls in nylon bearings, spaced on approximately 3" centers with stainless steel hardware. Conveyor to be provided with 16 gauge stainless steel bed of welded construction, ground and polished. Conveyor to be 34" high to top of rollers. Both longitudinal curbing for conveyor bed to have channeled edges with 1" turndown and extending 1-1/2" above the top of the roller. Structural supports to be stainless steel and welded to underside of conveyor bed. Each end of conveyor bed to be provided with tray stop and hand lift access with bed cleanout provision.

Leg assembly of 16 gauge tubular stainless steel 1-5/8" O.D. and 1" O.D. crossbracing completely welded.

(Continue specifications by selecting stationary or mobile model)

Stationary Unit

Fitted with adjustable stainless steel bullet feet.

Mobile Unit

Fitted with 5" diameter polyurethane tired casters, two with brakes. Conveyor shall have 6'-0" long power cord.

Optional Features:

1-1/4" O.D. Spring Loaded Plastic Rollers

Provide single row of full width 1-1/4" O.D. plastic rollers with stainless steel balls in nylon bearings, spaced at approximately 3" centers with stainless steel spring loaded hexagon snap-in shafts.

Wireway with Factory Installed Electric Outlets

Provide a recessed stainless steel wireway and electrical outlets with hinged moistureproof covers for adjoining mobile equipment on both sides. Outlets wired to one or more circuit breaker panel(s) as determined by application with each receptacle having its own circuit breaker control with manual reset feature and shutoff. All electrical work to be ready for single final connection by others to each circuit breaker panel at job site.

Specify number of outlets, as well as voltage, phase, wattage or motor size and location for each electrical plug-in outlet required. Preferred input voltage is 120/208v, 3ph, 5 wire system including ground.

IMPORTANT NOTE ON ELECTRICAL DATA

Maximum allowable amperage for mobile tray make-up conveyor is 100 amps, 3 phase. If total amperage exceeds 100 amp, 3 phase, a second circuit breaker panel will be required. A separate electrical connection is needed in the field for EACH circuit breaker panel on the conveyor.

Removable Work and Storage Shelf for Advance Make-Up of Soup and Beverages

Work and storage shelf to be **Model ACC-2010** made of 16 gauge stainless steel flanged up at rear and both sides. Shelf supported by stainless steel tubular leg with adjustable stainless steel bullet foot. Shelf size to be 20" X 10". Rear of shelf to be contoured to fit over and slide along curbing of conveyor and provided with positive locking clip to engage lower edge of conveyor bed.

Double Overshelf for Storage of Cookies, Crackers, Desserts, etc.

Double overshelf to be **Model ACC-6015** and to set on curbing of conveyor. to be approximately 5'-0" long with two shelves 15" wide of 16 gauge stainless steel turned down 1" on all four sides, supported by splayed legs of 1" O.D. 16 gauge stainless steel tubing with guides at bottom to slide to any convenient location.

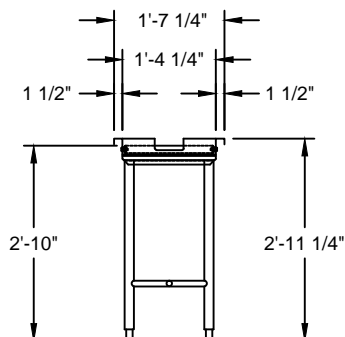

CADDY CORPORATION
 509 Sharptown Road P.O. Box 345
 Bridgeport, NJ 08014-0345
 Tel: 856-467-4222 Fax: 856-467-5511
 internet: www.caddycorp.com