

**8782 / 8788**  
**Gourmet 1000™**  
**Automatic Airpot**  
**Coffee Brewer**  
*(with Hot Water Faucet)*

**8782XL**  
**Gourmet 1000™**  
**Extra Low**  
**Automatic Airpot**  
**Coffee Brewer**  
*(with Hot Water Faucet)*

Airpot Coffee brewers offer volume brewing, proper extraction and holding capacity in a limited space. The 8782XL, at an extra low height of only 17 3/4", is sure to fit in those tight counters. These uniquely designed units eliminate flow control problems, and resist clogging in adverse water conditions. Coffee is brewed into a thermal server or airpot for easy transport to remote serving areas where the coffee will be preserved for optimal temperature and taste.



**Model 8782XL**  
*shown with optional 7874*



**Model 8788/8782**  
*shown with optional 7752*

## Features

- A high level of **commonality of parts** with other Bloomfield brewers will significantly reduce the inventory of spare parts required to service many body styles.
- Exclusive design provides **easy access** to components for quick, efficient service.
- **Water volume adjustments** can be made with ease; no tools required and no panels to remove.
- **Ready-to Brew light** indicates the proper water temperature to help eliminate guesswork in brewing.
- **Built-in pour over feature** provides flexibility of installation.
- **Premium quality thermostat** has a stainless steel bulb that recognizes water temperature extremely accurately and cycles less frequently.
- **Superior sprayhead design** spreads water over the coffee grounds, creating agitation and a floating action that completely saturates the coffee to capture the full rich essence of every bean.

- **Unique water valve with built-in flow control** assures consistent operation for inlet water pressures between 20 - 80 p.s.i..
- **Independent front mounted hot water faucet** allows drawing of hot water without affecting coffee taste or brew cycle.
- **One-piece drawn stainless steel water tank** has a superior design for extended life.
- **Rugged base rails** provide stability and strength while minimizing brewer height, and provides easy placement of airpot.
- High quality easy to clean **stainless steel construction**.

## Accessories

Bloomfield offers a full line of airpots, thermal servers and coffee grinders.



# BLOOMFIELD



**MODELS**  
**8788, 8782, 8782XL**

## DIMENSIONS

MODEL	A	B	C	D	E
8782 / 8782CA	17 1/8 (435)	13 3/4 (349)	2 5/16 (58)	21 3/4 (552)	9 1/4 (235)
8782XL / 8782XLCA	13 1/8 (333)	9 3/4 (248)	1 5/16 (33)	17 3/4 (451)	5 1/4 (133)
8788	17 1/8 (435)	13 3/4 (349)	2 5/16 (58)	21 3/4 (552)	9 1/4 (235)

DIMENSIONS: **INCH**  
(**MM**)

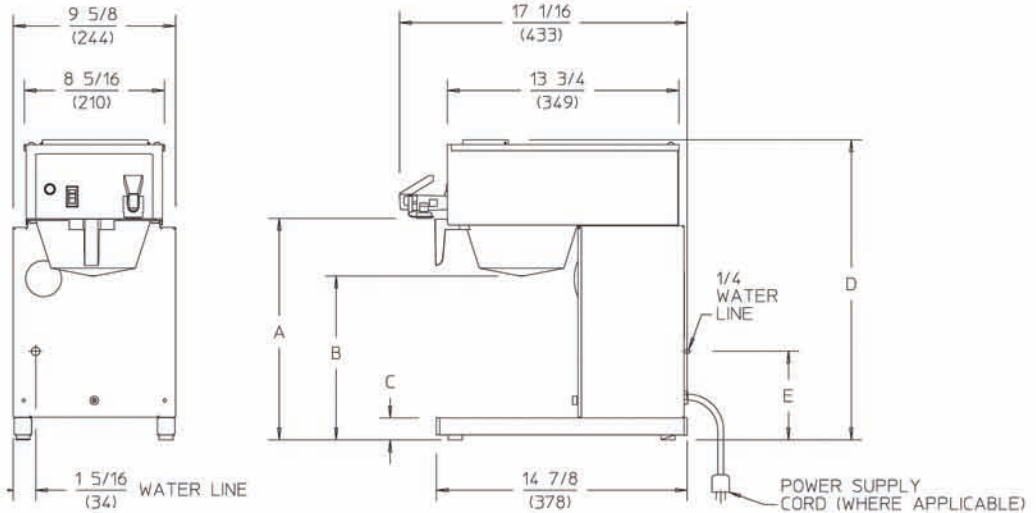

## SPECIFICATIONS:

MODELS	WATTS	VOLTS	AMPS	PHASE	POWER SUPPLY CORD
8782 / 8782XL	1800	120	15	SINGLE	NEMA 5-15P
8782CA / 8782XLCA	1500	120	12.5	SINGLE	NEMA 5-15P
8788	3500	115/230 4-WIRE	15	SINGLE	NONE

Meets Canadian standards

NOTE: Specifications are subject to change without notice and are not intended for installation purposes. See operation and maintenance manual for complete instructions.

ACCESSORIES: See the Bloomfield Brew Brew product catalog for a complete listing of brewers and accessories.

