

Cleveland

Parts Manual

PRESSURE STEAMERS



SERIES: PGM, PEM, PSM, PDM, PDL-2/3

MODELS B, C, F, K PRESSURE STEAMERS DOOR AND DOOR ARM ASSEMBLY

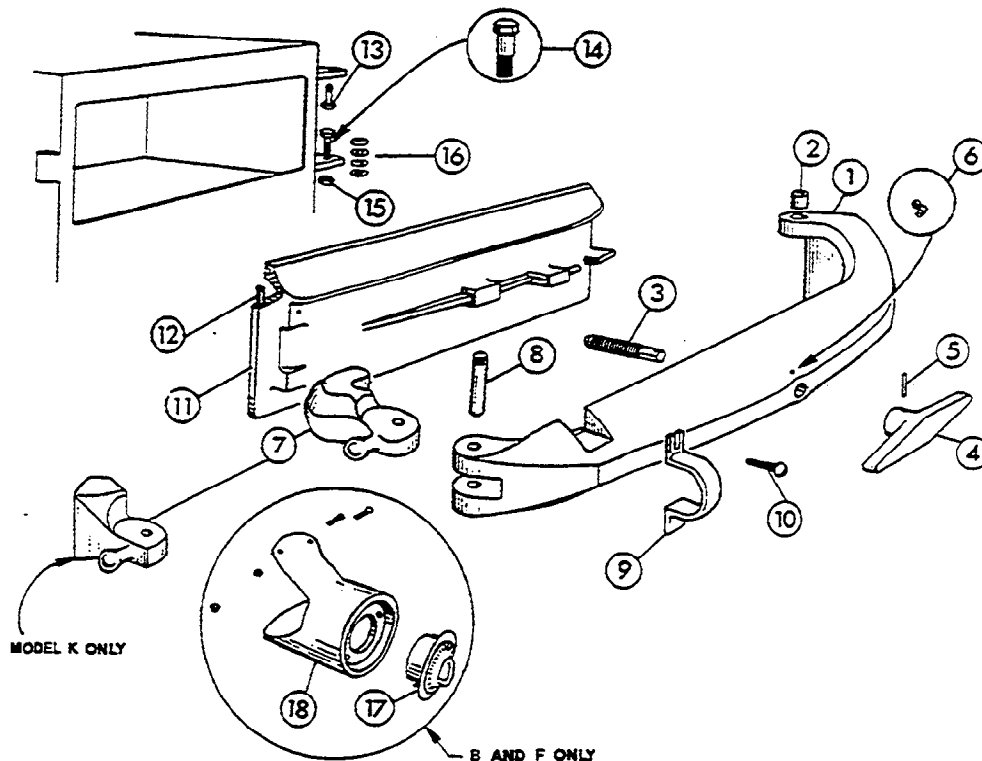

REFERENCE NUMBER	PART NUMBER	DESCRIPTION
1	25303	Door Arm With Bushings — Model B & C, Polished
	25304	Door Arm With Bushings — Model F & K, Polished
2	02568	Door Arm Hinge Bushing (2 Required)
3	41370	Standard Door Arm Screw With Ball (1" x 8 thread)
	41371	Oversize Door Arm Screw With Ball 1½" x 8 thread)
4	081001	Screw Handle Bar, Polished
5	16305	Pin
6	15250	Oil Cup
7	122011	Door Arm Latch — Model B, C, & F Chrome Plated
	122021	Door Arm Latch — Model K Chrome Plated
8	101018	Door Arm Latch Pin — Model B, C, F, & K Brass
	163101	Door Arm Latch Pin — Model B, C, F, & K Chrome Plated
9	081031	Door Retainer — Model B, C, F, & K Chrome Plated
10	19291	Screw
11	041631	Door, Model B Polished
	04164	Door, Model C Polished
	04165	Door, Model F & K Polished
12	07132	Door Gasket — Rubber, Model B
	07134	Door Gasket — Rubber, Model C, F, K
13	023001	Door Arm Hinge Post Bolt (Upper) — Concentric Type —
14	023061	Door Arm Hinge Post Bolt (Lower) — Eccentric Type —
15	14643	Nut, For Lower Hinge Post Bolt
16	23181	Shim Washer
17	40547	60 Minute Bell Timer Assembly
18	08601	Timer Housing — Model B & C Polished (Not Available)
	08606	Timer Housing — Model F Polished (Not Available)

CLEVELAND RANGE CO., 1333 EAST 179th ST., CLEVELAND, OHIO 44110

Manufacturer reserves right of design improvement or modification, as warranted.

MODEL J DOOR AND DOOR ARM ASSEMBLY

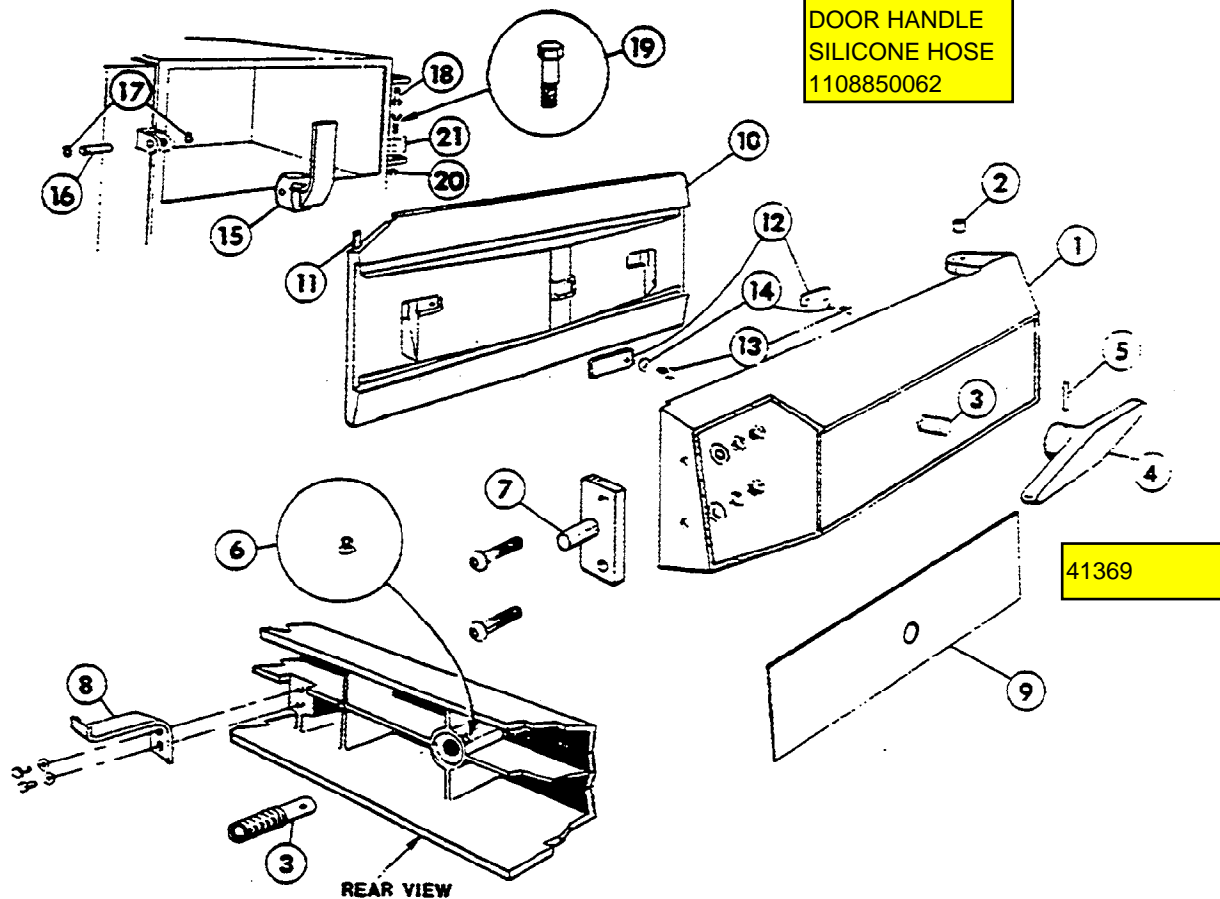

REFERENCE NUMBER	PART NUMBER	DESCRIPTION
1	253022	Door Arm Painted
2	02568	Door Arm Hinge Bushing (2 Required)
3	41370	Standard Door Arm Screw With Ball (1" x 8 thread)
	41371	Oversize Door Arm Screw With Ball (1 1/32" x 8 thread)
4	081001	Screw Handle Bar, Polished
5	16305	Pin
6	15250	Oil Cup
7	41360	Striker Plate and Pin
8	43723	Door Hanger w/Screws and Washers (2 Required)
9	53035	Door Arm Insert, Stainless
10	04162	Polished Aluminum Door, 041623 Door Painted
11	07136	Door Gasket — Rubber
12	68140	Retainer, Yoke Hanger (2 Required)
13	19228	Screw
14	23182	Washer
15	122001	Door Arm Latch, Chrome Plated
16	163141	Door Arm Latch Pin, Chrome Plated
17	18306	Retainer Clip, (2 Required)
18	023001	Door Arm Hinge Post Bolt (Upper) — Concentric Type —
19	023061	Door Arm Hinge Post Bolt (Lower) — Eccentric Type —
20	14643	Nut, For Lower Hinge Post Bolt
21	23181	Shim Washers

CLEVELAND RANGE CO., 1333 EAST 179th ST., CLEVELAND, OHIO 44110

Manufacturer reserves right of design improvement or modification, as warranted.

MECHANICAL COMPARTMENT CONTROLS MODEL J PRESSURE STEAMERS—JAN. 1982 THRU PRESENT

LTHO IN USA. 0982

CLEVELAND RANGE CO., 1333 EAST 179th ST., CLEVELAND, OHIO 44110
 Manufacturer reserves right of design improvement or modification, as warranted.

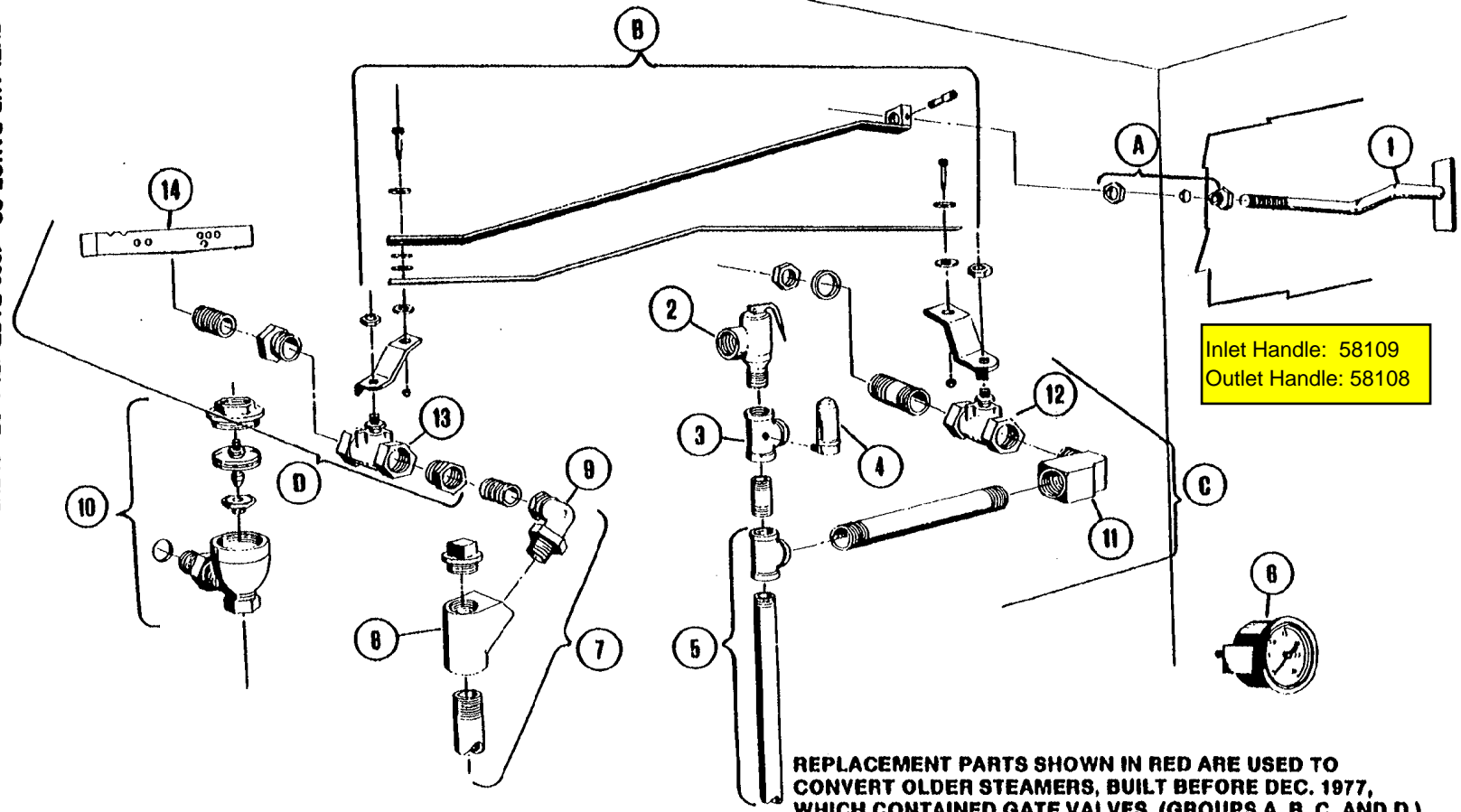

CLEVELAND RANGE CO., 1333 EAST 179th ST., CLEVELAND, OHIO 44110

Manufacturer reserves right of design improvement or modification, as warranted.

MECHANICAL COMPARTMENT CONTROLS MODEL J PRESSURE STEAMERS—JAN. 1982 THRU PRESENT

REFERENCE NUMBER	PART NUMBER	DESCRIPTION
1	40850	Pull Rod Handle
2	22130	Valve, Safety, 8 PSI
3	70411	Tea, Special 3/4"
4	22140	Air Vent
5	42278	Inlet Manifold Ass'y.—2-Compt.—Mech. "J", Less Valves
	42277	Inlet Manifold Ass'y.—3-Compt.—Mech. "J", Less Valves
6	07173	Gauge, Pressure, Rear Mount, 0-30 PSI
7	42288	Exhaust Manifold Ass'y.—2-Compt., Model "J", Less Valves
	42289	Exhaust Manifold Ass'y.—3-Compt., Model "J", Less Valves
8	02146	"Y" Bend
9	05263	Ell, 3/4" Radiator Union
10	20561	Thermostatic Trap—Plain End
11	05252	Ell, 1/2" Street
12	22212	Valve, 1/2" Ball, Inlet Steam
13	22213	Valve, 1" Butterfly, Exhaust Steam
14	41100	Drain Cover Screen
A	43765	Bushing Ass'y.
B	40879	Linkage Ass'y., Model "J"
C	42697	Conversion Kit, Inlet Valve—"J" Mech., Includes: 1/2" Inlet Steam Valve, 1/2" Street Elbow, 1/2" x 6" Nipple, 1/2" x 2 1/4" Special Nipple, (2) Locknuts, (2) Sealing Washers
D	40710	Conversion Kit, Exhaust Valve, Includes: 1" Exhaust Steam Valve, (2) 1" x 3/4" Bushings, 3/4" Close Nipple, Drain Cover Screen.

NOTE: FOR SAFETY PURPOSES, DRAIN SCREEN COVER MUST BE IN PLACE WHEN OPERATING EQUIPMENT.

**AUTOMATIC COMPARTMENT CONTROLS
MODEL J PRESSURE STEAMERS—
DEC. 1977 THRU PRESENT**

LTHO IN USA 1082

CLEVELAND RANGE CO., 1333 EAST 179th ST., CLEVELAND, OHIO 44110
Manufacturer reserves right of design improvement or modification, as warranted.

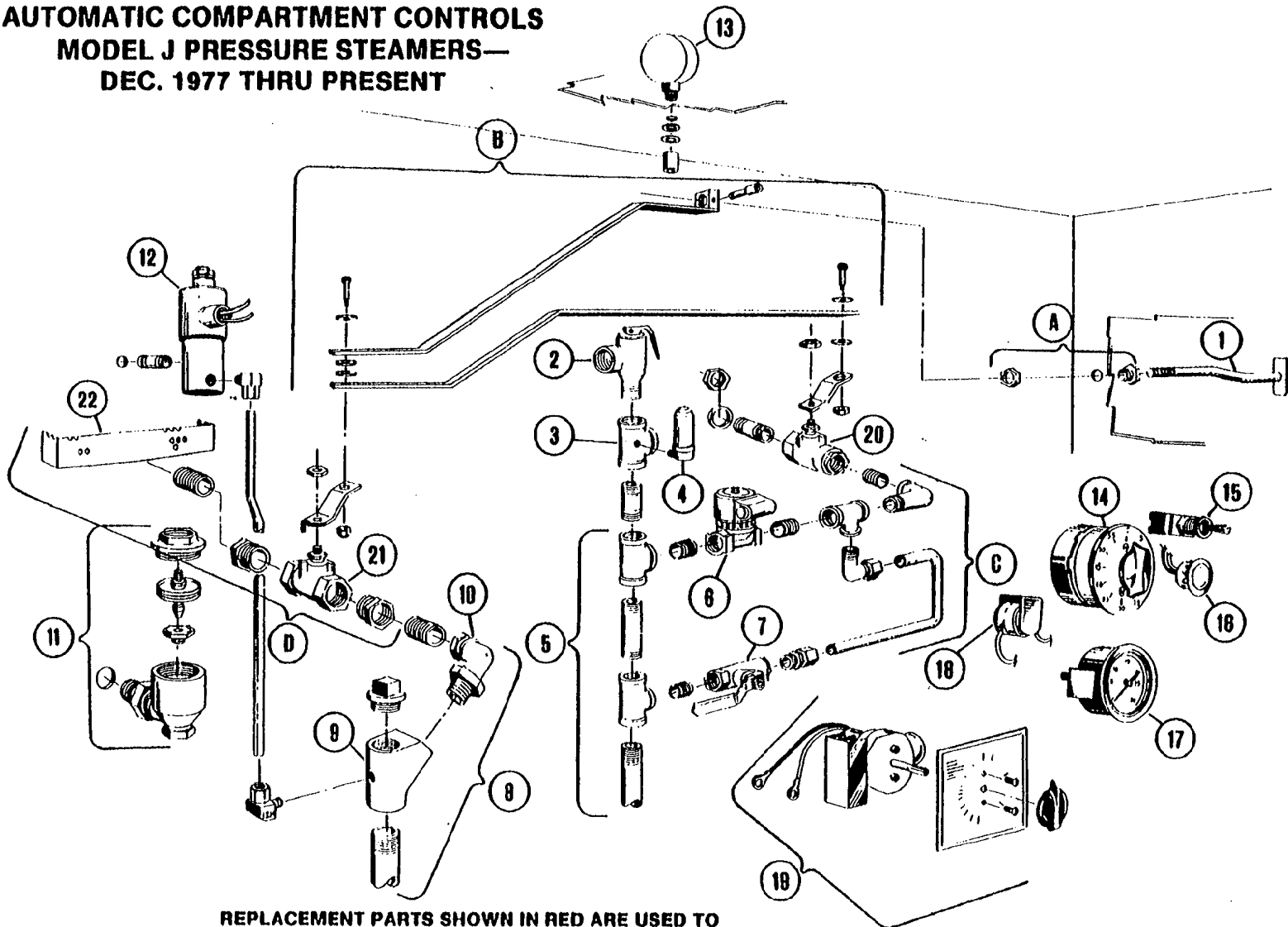

**REPLACEMENT PARTS SHOWN IN RED ARE USED TO
CONVERT OLDER STEAMERS, BUILT BEFORE DEC. 1977,
WHICH CONTAINED GATE VALVES. (GROUPS A, B, C, D.)**

CLEVELAND RANGE CO., 1333 EAST 179th ST., CLEVELAND, OHIO 44110
 Manufacturer reserves right of design improvement or modification, as warranted.

AUTOMATIC COMPARTMENT CONTROLS MODEL J PRESSURE STEAMERS—DEC. 1977 THRU PRESENT

REFERENCE NUMBER	PART NUMBER	DESCRIPTION
1	40850	Pull Rod Handle
2	22130	Valve, Safety, 8 PSI
3	70411	Tee, Special ¾"
4	22140	Air Vent
5	42286	Inlet Manifold Ass'y.—2-Compt.—Auto "J", Less Valves
	42297	Inlet Manifold Ass'y.—3-Compt.—Auto "J", Less Valves
6	22115	Valve, ½" Steam Inlet Solenoid
7	03278	Valve, Steam By-Pass
8	42288	Exhaust Manifold Ass'y.—2-Compt., Model "J", Less Valves
	42289	Exhaust Manifold Ass'y.—3-Compt., Model "J", Less Valves
9	43764	"Y" Bend—with ¼" Tapped Hole
10	05263	Elb, ¾" Radiator Union
11	20551	Thermostatic Trap—Plain End
12	22199	¼" Solenoid Valve, Auto Exhaust, 115 Volt, For Use With 40518 Timer
	22185	¼" Solenoid Valve, Auto Exhaust, 115 Volt, For Use With 40540 Timer
13	07172	Gauge, Pressure, Bottom Mount, 0-30 PSI
14	40518	Timer, 60 Min. Mechanical (Mfg. #70000)
15	19977	Switch—SPST
16	12161	Light, Signal
17	07173	Gauge, Pressure, Rear Mount, 0-30 PSI
18	41350	Buzzer
19	40540	Timer, 105 Min. (Mfg. 601)
20	22212	Valve, ½" Ball, Inlet Steam
21	22213	Valve, 1" Butterfly, Exhaust Steam
22	41100	Drain Cover Screen
A	43765	Bushing Ass'y.,
B	40879	Linkage Ass'y., Model "J"
C	40712	Conversion Kit, Inlet Valve—"J" Auto, Includes: ½" Inlet Steam Valve, ½" Street Elbow, ¾" Tube Fing., ¾" — 90° Tube Fing., (2) ½" Close Nipples, ½" x 2¼" Special Nipple, ½" x ½" x ¾" Tee, ¾" x 12" Tube, (2) Locknuts, (2) Sealing Washers
D	40710	Conversion Kit, Exhaust Valve, Includes: 1" Exhaust Steam Valve, (2) 1" x ¾" Bushings, ¾" Close Nipple, Drain Cover Screen.

NOTE: FOR SAFETY PURPOSES, DRAIN SCREEN COVER MUST BE IN PLACE WHEN OPERATING EQUIPMENT

MODELS J AND K PRESSURE STEAMER SLIDE SETS

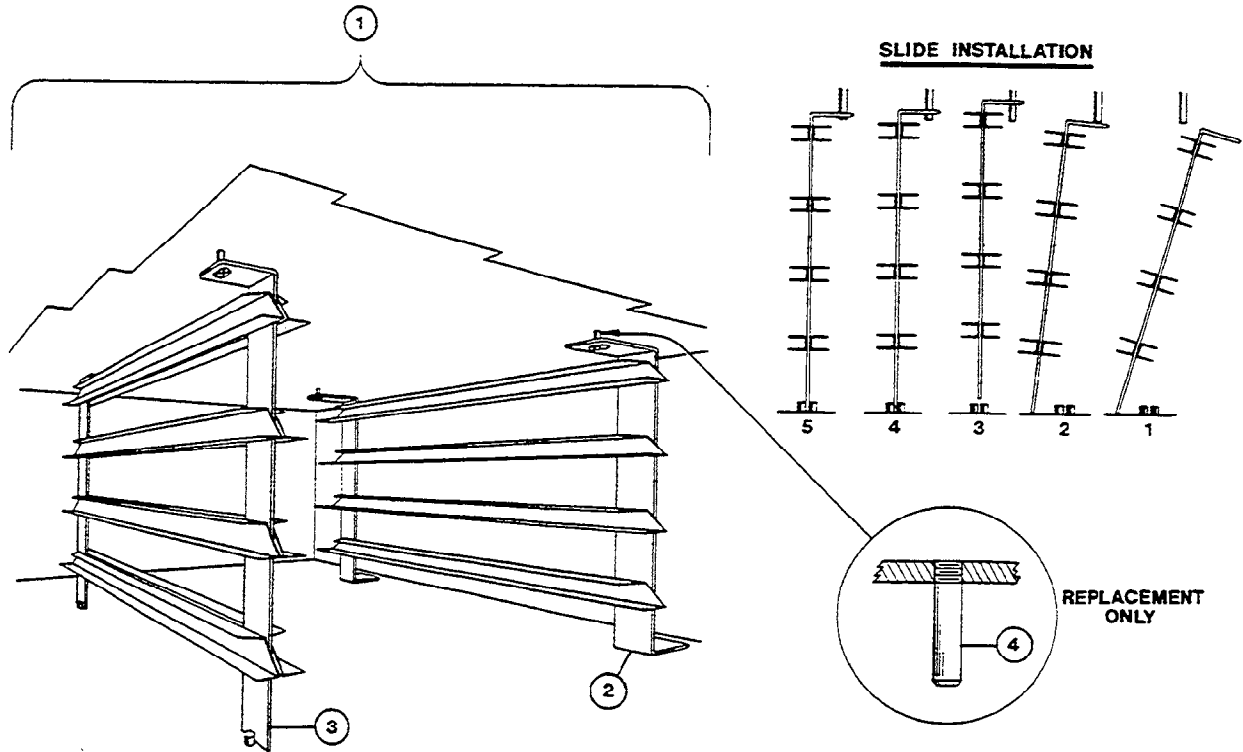

REFERENCE NUMBER	PART NUMBER	DESCRIPTION
1	41440	Pan Support Slide Set, Model J Complete
	41442	Pan Support Slide Set, Model K Complete
2	41430	Right or Left Side Slide Rack, 2 Per Compt Req'd, Model J
	41432	Right or Left Side Slide Rack, 2 Per Compt Req'd, Model K
3	41435	Center Slide Rack Model J, 1 Req'd Per Compt
	41437	Center Slide Rack Model K, 1 Req'd Per Compt
4	19909	Replacement Top Studs (Screw-In) J or K (Set of 6)

CLEVELAND RANGE, INC., 1333 EAST 179th ST., CLEVELAND, OHIO 44110

Manufacturer reserves right of design improvement or modification, as warranted.

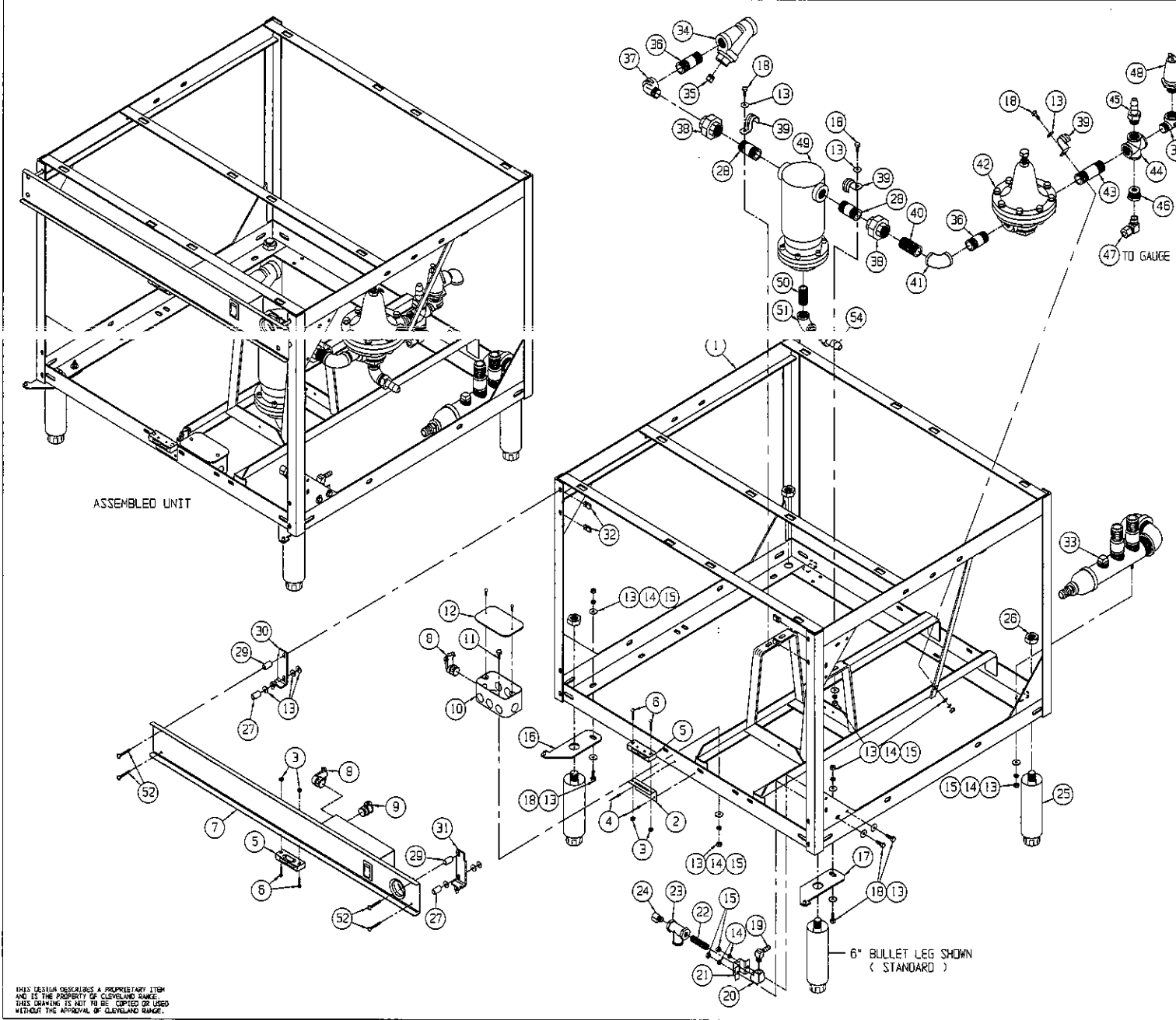

LET.	REVISIONS	DATE	BY
54	1	05241	FITTING, HOSE, 3/4 H X 1/2 NPT
53	1	05250	ELBOW, STREET, 3/4 X 90°, BLK
52	4	106598	SCREW, TEE HD, PHILPS, 10-24 X 1-1/2
51	1	05249	ELBOW, 1/2", BLACK, 90°
50	1	14323	NIPPLE, 1/2" X CLOSE, BLACK
49	1	19020	TRAP, SEPARATOR COMBINATION
48	1	22131	VALVE, SAFETY 3/4, 15# PSI
46	1	02563	BRUSHING, HEX 3/4 X 1/4 BRASS
45	1	05240	FITTING, HOSE 3/4 H X 3/4 NPT
44	1	03732	CROSS, 4-WAY, 3/4 BRASS
43	1	14348	NIPPLE, 3/4 X 3, BRASS
42	1	22122	VALVE, 3/4 PRESSURE REDUCING
41	1	05260	ELBOW, 3/4 X 90°, BRASS
40	1	14342	NIPPLE, 3/4 X CLOSE, BRASS
39	3	03197	CLAMP, RIGID, 3/4" HOLE
38	2	21304	UNION, 3/4 REG BRASS
37	2	05231	ELBOW, STREET 3/4 X 90° BRASS
36	2	14431	NIPPLE, 3/4 X 2, BRASS
35	1	16601	PLUG, 3/8", BLACK
34	1	19872	STRAINER, "Y" PIPE FITTING 3/4 NPT
33	1	42752	GRAIN ASSY.
32	4	106599	NUT, SLIP ON, 10-24, TINNERMAN
31	1	412192	HINGE, UPPER RIGHT HINGE
30	1	412182	HINGE, UPPER LEFT HINGE
29	2	19555	SPACER, 1/4 ID X 13/16" LG
28	2	14346	NIPPLE, 3/4 X 2-1/2, BRASS
27	2	19552	SPACER, 1/4 ID X 11/16" LG
26	4	14568	NUT, HEX JAN 3/4-10
25	4	06156	LEG, BULLET 6"
24	1	05235	ELBOW, STREET 1/4 X 90°
23	1	19870	STRAINER, "Y" 1/4" 27 LB.
22	1	14304	NIPPLE, 1/4 X CLOSE, BRASS
21	1	100064	CLAMP, MOUNTING 1/4" TEE, S/S
20	1	05236	ELBOW, 1/4 X 90° BRASS
19	1	105786	FITTING, HOSE BARB, 1/4H X 1/4 NPT, 90°
18	7	19288	SCREW, HEX HEAD, 1/4-20 X 3/4
17	1	1020663	HINGE, LOWER RIGHT HINGE
16	1	1020662	HINGE, LOWER LEFT HINGE
15	9	14818	NUT, HEX 1/4-20 S/S
14	9	23105	WASHER, LOCK 1/4 KATLINK STYLE
13	17	23116	WASHER, PLAT 1/4 X 5/8 X .005
12	1	02369	HAND-BOX COVER
11	1	19218	SCREW, HEX HEAD 1/4-20 X 3/8
10	1	02351	HAND-BOX, ELECTRIC BOX
9	1	105243	CONNECTOR, GREENFIELD, 3/8 START.
8	2	105245	CONNECTOR, GREENFIELD, 3/8 X 90°
7	1	1045071	CONSOLE ASSY, 900 MM, 1 SW, CONTROL
6	4	19205	SCREW, HD HEAD 5-32 X 1 ZINC PLTD.
5	2	03100	CATCH, MAGNETIC
4	2	18359	RIVET 1/8" DIA, BLUSH BREAK S/S
3	4	14574	NUT, HEX 5-32 ZINC PLATED
2	1	532741	BRACKET, MAGNET CATCH, A.C.S.
1	-	411241	BASE WELDMENT, A.C.S., O.C.
1	-	41124	BASE WELDMENT, S/S, O.C.
ITEM	QTY	PART NO.	DESCRIPTION
TOLERANCES UNLESS OTHERWISE SPECIFIED			
CLEVELAND RANGE INC.			
1323 East 179th St., Cleveland, Ohio 44110-2574			
DECIMAL	SCALE	DRAWN BY	APPROVED BY
N/A	1:4=1	EAG	
INCHES	TITLE	CONNECTOR STEAMER ASS'Y.	
N/A		SQUARE BASE, DIRECT CHANNEL	
DATE	DRAWING NO.	SHEET 2 OF 2 REV.	
06	11-04-94	0 - 0K0029	

THIS DESIGN DESCRIBES A PROPRIETARY ITEM AND IS THE PROPERTY OF CLEVELAND RANGE. THIS DRAWING IS NOT TO BE COPIED OR USED WITHOUT THE APPROVAL OF CLEVELAND RANGE.

6" BULLET LEG SHOWN (STANDARD)