



Visit [www.clevelandrange.com](http://www.clevelandrange.com) to locate a service or sales representative in your area.

# Cleveland

## SteamChef

### Gas Convection Steamers with Easy Timer

### Operation, Installation & Maintenance Manual

This manual is updated as new information and models are released. Visit our website for the latest manual.

**MODELS:**

- 22CGT3.1
- 22CGT6.1

*For your future reference.*

Model # \_\_\_\_\_

Serial # \_\_\_\_\_



**Read the manual thoroughly.  
Improper installation, operation or  
maintenance can cause property  
damage, injury, or death.**

# **STATEMENT OF RESPONSIBILITIES / DÉCLARATION DES RESPONSABILITÉS / DECLARACIÓN DE RESPONSABILIDADES**

This document is for use by experienced and trained Qualified Cleveland Range, LLC Authorized Service Representatives who are familiar with both the safety procedures, and equipment they service. Cleveland Range, LLC assumes no liability for any death, injury, equipment damage, or property damage resulting from use of, improper use of, or failure to use the information contained in this document. Cleveland Range, LLC has made every effort to provide accurate information in this document but cannot guarantee that this document does not contain unintentional errors and omissions.

The information in this document may be subject to technical and technological changes, revisions, or updates. Cleveland Range, LLC assumes no liability or responsibility regarding errata, changes, revisions, or updates.

Qualified Cleveland Range, LLC Authorized Service Representatives are obligated to follow industry standard safety procedures, including, but not limited to, OSHA regulations, and disconnect / lock out / tag out procedures for all utilities including steam, and disconnect / lock out / tag out procedures for gas, electric, and steam powered equipment and / or appliances.

All utilities (gas, electric, water and steam) should be turned OFF to the equipment and locked out of operation according to OSHA approved practices during any servicing of Cleveland Range equipment.

Qualified Cleveland Range, LLC Authorized Service Representatives are obligated to maintain up-to-date knowledge, skills, materials, and equipment.

Ce document est destiné à l'usage des Représentants de Service qualifiés et autorisés de Cleveland Range, LLC qui possèdent l'expérience et la formation ainsi que la bonne connaissance des mesures de sécurité et du matériel qu'ils entretiennent.

Cleveland Range, LLC décline toute responsabilité pour tout cas de décès, blessure, dommage matériel ou dommage aux biens résultant de l'utilisation, de la mauvaise utilisation ou du manquement d'utilisation des renseignements contenus dans ce document.

Cleveland Range, LLC s'est efforcé à fournir des renseignements précis dans ce document mais ne peut garantir que ce document soit exempt d'erreurs et d'omissions non intentionnelles.

Les renseignements contenus dans ce document peuvent être assujettis à des changements techniques et technologiques, des révisions ou des mises à jour.

Cleveland Range, LLC décline toute obligation ou responsabilité concernant les errata, modifications, révisions ou mises à jour.

Les Représentants de Service qualifiés et autorisés de Cleveland Range, LLC sont tenus de se conformer aux mesures de sécurité normalisées de l'industrie, y compris, mais sans s'y limiter, les réglementations de l'OSHA, les procédures de débranchement / verrouillage / étiquetage relatives à tous les services publics, dont l'approvisionnement en vapeur, et les procédures de débranchement / verrouillage / étiquetage relatives aux équipements et/ou appareils fonctionnant au gaz, à l'électricité et à la vapeur.

Au cours de tout entretien d'un appareil Cleveland Range, tous les services publics (gaz, électricité, eau et vapeur) doivent être FERMÉS au niveau de l'appareil et le dispositif de fonctionnement doit être verrouillé suivant les pratiques approuvées de l'OSHA.

Les Représentants de Service qualifiés et autorisés de Cleveland Range, LLC sont tenus d'actualiser en permanence leurs connaissances, compétences, matériel et équipement.

Este documento está destinado para el uso de los Representantes de Servicio calificados y autorizados de Cleveland Range, LLC quienes cuentan con la experiencia y la capacitación, así como el buen conocimiento de las medidas de seguridad y de los equipos que mantienen.

Cleveland Range, LLC, declina toda responsabilidad en caso de cualquier fallecimiento, lesiones, daños al equipo o daños a la propiedad resultantes de la utilización, del uso indebido o de la falta de utilización de la información provista en este documento.

Cleveland Range, LLC se ha esforzado en suministrar información precisa en este documento, pero no puede garantizar que este documento esté exento de errores y de omisiones no intencionales.

La información contenida en este documento podría estar sujeta a cambios técnicos o tecnológicos, revisiones o actualizaciones. Cleveland Range, LLC declina toda obligación o responsabilidad con respecto a erratas, modificaciones, revisiones o actualizaciones.

Los Representantes de Servicio calificados y autorizados de Cleveland Range, LLC tienen la obligación de seguir los procedimientos estándar de seguridad de la industria; los cuales incluyen pero no se limitan a los reglamentos de la OSHA (La Administración de la Seguridad y Salud Ocupacionales), los procedimientos de desconexión, cierre y etiquetado relativos a todos los servicios públicos incluyendo el suministro de vapor y los procedimientos de desconexión, cierre y etiquetado para los equipos y/o aparatos que funcionan a base de gas, electricidad o vapor.

Cuando se esté dando servicio o mantenimiento a un aparato de Cleveland Range, todos los servicios públicos (gas, electricidad, agua y vapor) deben estar APAGADOS para el equipo en cuestión y se debe seguir el procedimiento de cierre de operaciones de acuerdo con las prácticas aprobadas por la OSHA.

Los Representantes de Servicio calificados y autorizados de Cleveland Range, LLC tienen la obligación de actualizar constantemente sus conocimientos, destrezas, materiales y equipamiento.

**FOR YOUR SAFETY / POUR VOTRE SÉCURITÉ /  
PARA SU SEGURIDAD**

**FOR YOUR SAFETY**

Do not store or use gasoline or any other flammable liquids and vapours in the vicinity of this or any other appliance.

**WARNING:** Improper installation, operation, adjustment, alteration, service, or maintenance can cause property damage, injury or death. Read the installation and operating instructions thoroughly before installing, operating, or servicing this equipment.

Do not spray aerosols in the vicinity of this appliance while it is in operation.

This appliance is not to be used by persons with reduced physical, sensory, or mental capabilities, or lack of experience and knowledge, unless they have been given supervision or instruction concerning use of the appliance by a person responsible for their safety.

This appliance is not for use by children, and they must be supervised not to play with it.

Retain this manual for your reference.

**POUR VOTRE SÉCURITÉ**

Ne pas entreposer ou utiliser d'essence ou d'autres liquides ou vapeurs inflammables à proximité de cet appareil ou de tout autre appareil.

**AVERTISSEMENT :** Toute mauvaise pratique en matière d'installation, de fonctionnement, de réglage, de modification, d'entretien ou de maintenance peut causer des dommages matériels, des blessures ou la mort. Lisez la totalité des instructions d'installation et d'utilisation avant d'installer, d'utiliser ou d'entretenir cet équipement.

Ne pas pulvériser des aérosols dans le voisinage de cet appareil alors qu'il est en fonctionnement.

Cet appareil ne doit pas être utilisé par des personnes dont les capacités physiques, sensorielles ou mentales sont réduites, ou des personnes dénuées d'expérience ou de connaissance, sauf si elles ont pu bénéficier, par l'intermédiaire d'une personne responsable de leur sécurité, d'une surveillance ou d'instructions préalables concernant l'utilisation de l'appareil.

Conservez ce manuel pour votre référence.

**PARA SU SEGURIDAD**

No guarde ni use gasolina o cualesquiera otros líquidos o vapores inflamables en las cercanías de éste o cualquier otro aparato.

**ADVERTENCIA:** La indebida instalación, operación, ajuste, modificación, servicio o mantenimiento puede ocasionar daños a la propiedad, lesiones o muerte. Lea detenidamente las instrucciones de instalación y de operación antes de instalar, poner a funcionar o dar servicio a este equipo.

No pulverice aerosoles en las proximidades de este aparato mientras está en funcionamiento.

Este aparato no debe ser utilizado por personas con capacidades físicas, sensoriales o mentales reducidas, o que no tengan la experiencia y los conocimientos adecuados, a menos que estas personas hayan recibido supervisión e instrucciones en cuanto al uso del aparato por la persona responsable de la seguridad de ellas.

Guarde este manual para su referencia.

## WARNING / AVERTISSEMENT / ADVERTENCIA



Inspect unit daily for proper operation. / Inspecter le bloc quotidiennement pour garantir le fonctionnement normal. / Inspeccione diariamente el funcionamiento correcto de la unidad.



Heavy. / Lourd. / Pesado.

Team or mechanical lift. / Levage en équipe ou mécanique. / Levantamiento en equipo o mecánico.



Surfaces may be extremely hot! Use protective equipment. / Les surfaces peuvent être extrêmement chaudes ! Utiliser des équipements de protection. / ¡Las superficies pueden estar muy calientes! Utilice equipo protector.



Do not climb, sit, or stand on equipment. / Il ne faut pas monter, s'asseoir ni se tenir debout sur l'équipement. / No subirse, ni sentarse ni pararse sobre el equipo.



Do not remove guards or operate without them. / Ne pas supprimer les gardes ou fonctionner sans eux. / No retire los guardias ni funcionar sin ellos.



Keep hands away from moving parts and pinch points. / Tenir les mains à l'abri des pièces mobiles et des angles. / Mantenga las manos lejos de las piezas móviles y los puntos de presión.



Hot product and surfaces. / Produit et surfaces chaudes. / Producto y superficies calientes.



Keep clear of pressure discharge. / Se tenir hors de portée de la purge des soupapes de surpression. / Manténgase alejado de la descarga de presión.



Unit must be anchored as per manual. / Unité doit être ancrée selon les directives du manuel. / Unidad debe estar fijado según el manual.



Floor may become slippery from product spillage. / Déversement de produit peut causer de plancher à être glissant. / Derrame de producto puede causar piso a ser resbaladizo.



Have a qualified service technician maintain your equipment. / Demandez à un technicien en entretien et en réparation qualifié d'effectuer l'entretien de votre équipement. / Haga que un técnico de servicio calificado mantenga su equipo.



Shut off power at main fuse disconnect prior to servicing. / Couper l'alimentation sur le principal fusible sectionneur avant l'entretien. / Apague la alimentación eléctrica en el fusible desconector principal antes de darle servicio.



Ensure equipment is at room temperature and pressure gauge is showing zero or less prior to removing any fittings. / S'assurer que le chaudron se trouve dans une température ambiante et que le manomètre affiche zéro ou moins avant de déposer les raccords. / Asegúrese de que la marmita está a temperatura ambiente y el manómetro está mostrando cero o menos antes de quitar cualquier accesorio.



Appliance must not be supplied through an external switching device that is regularly switched on and off. / L'appareil ne doit pas être alimenté par un interrupteur externe régulièrement allumé et éteint. / El aparato no debe ser alimentado a través de un dispositivo de conmutación externo que se encienda y apague periódicamente.

**OPERATION, INSTALLATION & MAINTENANCE MANUAL STEAMCHEF MODELS  
22CGT3.1 & 22CGT6.1  
Table of Contents**

<b>CHAPTER 1 GENERAL INFORMATION.....</b>	<b>5</b>
A. Laws, Codes, and Regulations .....	5
B. Gas Leak Instructions .....	5
C. Operational Safety .....	5
D. Inspection for Shipping Damage .....	6
<b>CHAPTER 2 PRODUCT INFORMATION.....</b>	<b>7</b>
<b>CHAPTER 3 INSTALLATION PROCEDURE.....</b>	<b>10</b>
A. Select a Location .....	10
B. Exhaust Hood Requirements .....	10
C. Lifting Points.....	11
D. Install the Legs .....	11
E. Position and Level the SteamChef .....	12
F. Gas Supply for the SteamChef.....	12
G. Water Connections for the SteamChef .....	13
H. Electric Connections for the SteamChef .....	15
I. Install the Free Air Vented Drain Line.....	16
J. Install the Fan Guard and Air Diverter .....	17
K. Install the KleanShield™ .....	18
L. Install the Slide Racks (Pan Racks).....	18
M. Installation Check List .....	19
<b>CHAPTER 4 COOKING WITH THE SteamChef.....</b>	<b>20</b>
A. Operating and Cooking Procedure – All Models .....	20
B. Rethermalization:.....	21
<b>CHAPTER 5 EASY TIMER OPERATING INSTRUCTIONS.....</b>	<b>22</b>
A. Main External Power Switch.....	23
B. To Inspect the Cooking Compartment .....	23
C. Power ON (Automatic Water Fill / Automatic Preheat) .....	23
D. Lighting and Shutdown Instructions (Normal Operation) .....	24
E. Turn Off the Main Manual Gas Valve .....	25
F. High Limit Reset .....	25
<b>CHAPTER 6 SHUTDOWN AND CLEANING PROCEDURE .....</b>	<b>26</b>
<b>CHAPTER 7 OPERATING TESTS AND FINAL CHECKOUT PROCEDURES.....</b>	<b>28</b>
A. Burner Ignition Test .....	28
B. Startup Procedure.....	29
C. Drain Rinse Inspection (Continued from Item 1, Startup Procedure) .....	29
D. Operating Tests (Continued from Drain Rinse Inspection) .....	30
E. Shutdown of the SteamChef after Testing (Continued from Operating Tests) and Front Burner Cover Installation .....	32
<b>CHAPTER 8 PREVENTATIVE MAINTENANCE.....</b>	<b>33</b>
A. Maintenance.....	33
B. Descaling Water Reservoir.....	34
<b>CHAPTER 9 TROUBLESHOOTING GUIDE.....</b>	<b>36</b>

# CHAPTER 1 GENERAL INFORMATION

---

## A. Laws, Codes, and Regulations

This equipment should be installed only by qualified, professional plumbers, pipe fitters, and electricians.

1. The installation of this appliance must conform with:
  - a) The National Fuel Gas Code, ANSI Z223.1 / NFPA 54 (latest edition), or the Natural Gas and Propane Installation Code CSA B1 49.1, as applicable.
  - b) The National Electrical Code, ANSI/NFPA 70 (latest edition), or the Canadian Electrical Code, CSA C22.2, as applicable.
    - When installed, the appliance must be electrically grounded in accordance with the above.
    - **NOTE:** This appliance is not GFI (GFCI) compatible.
  - c) The *Food Code* (latest edition) of the Food and Drug Administration (FDA).
2. This equipment is to be installed to comply with the applicable federal, state, or local plumbing codes.
3. Installation instructions must be read in their entirety before starting installation.
4. Install this appliance according to the policies and procedures outlined in this manual.
5. Installation must comply with **all** local fire and health codes.

### **DANGER**

Improper installation, adjustment, alteration, service, or maintenance of this appliance, or installation of a damaged appliance can result in DEATH, INJURY, EQUIPMENT DAMAGE, and void the warranty.

**NEVER** install damaged appliances, equipment, or accessories.

**ALWAYS** have installation and service performed by qualified Cleveland Range authorized personnel.

## B. Gas Leak Instructions

### **DANGER**

Gas leaks are fire and explosion hazards. INJURY, DEATH, and PROPERTY DAMAGE will result.

If anyone smells gas, or suspects there is a gas leak, immediately refer to the posted gas leak instructions. The posted instructions are provided by the local gas supplier and supersede any other instructions.

**Observe the following precautions in addition to the posted instructions:**

- Do NOT light or start any appliance.
- Do NOT touch any electrical switch.
- Do NOT use any phone in the building.
- Immediately call the gas supplier from a phone away from the building.
- Follow the gas supplier's instructions.
- If the gas supplier cannot be reached, call the fire department.

## C. Operational Safety

The Operational Safety section outlines minimum safety policies and procedures for operating one or more Cleveland Range appliances.

1. Do not store anything on top and underneath the appliance.
2. **KEEP THE APPLIANCE AREA FREE AND CLEAR OF COMBUSTIBLES.**
3. Proper air supply for ventilation is **REQUIRED** for and **CRITICAL** to safe, efficient operation of this appliance.
4. Place non-slip draining anti-fatigue mats rated for use in wet, greasy, or dry work areas on the floor in front of the appliance and other locations as needed. Obtain the best mats for your needs from your local supplier.

5. Wear BOOTS appropriate to the work area to help protect feet, and to help prevent slips and falls.
6. Allow only qualified Cleveland Range authorized service representatives to service the appliance.
7. Use only factory authorized repair parts.
8. Maintain written records of appliance service, maintenance, and repair. See Chapter 6.

## **DANGER**

Operating this appliance out of level can cause DEATH, INJURY, and EQUIPMENT DAMAGE.

This appliance must be level both front-to-back and side-to-side in all installations.

NEVER operate this appliance out of level.

If this appliance is suspected to be out of level, shut it down at once and call your qualified Cleveland Range authorized service agency immediately.

### **D. Inspection for Shipping Damage**

If the appliance is damaged or damage is suspected:

1. Submit a Damage Claim to the shipper and inform your dealer immediately.
2. Inform Cleveland Range in writing within three (3) days.

## CHAPTER 2 PRODUCT INFORMATION

---

### A. Product Information

- This manual covers the operation of 22CGT3.1 and 22CGT6.1 SteamChef Steam Cookers (steamers), and their standard features and options.
- Other than the selection of options and size (3 or 6 pan), there are presently no significant design, parts, or operating differences among appliances with these model numbers.
- Figures 2-1, 2-2, and 2-3 illustrate the major external features of 22CGTs.

### B. Model Numbers and Serial Numbers

1. Cleveland Range, LLC assigns two product identification numbers to each appliance: a model number and a serial number.
2. Please provide the model number and serial number when you contact Cleveland Range or a qualified Cleveland Range authorized service representative.

- Model Number \_\_\_\_\_

(Write the Model Number of your appliance here)

- Serial Number \_\_\_\_\_

(Write the Serial Number of your appliance here)

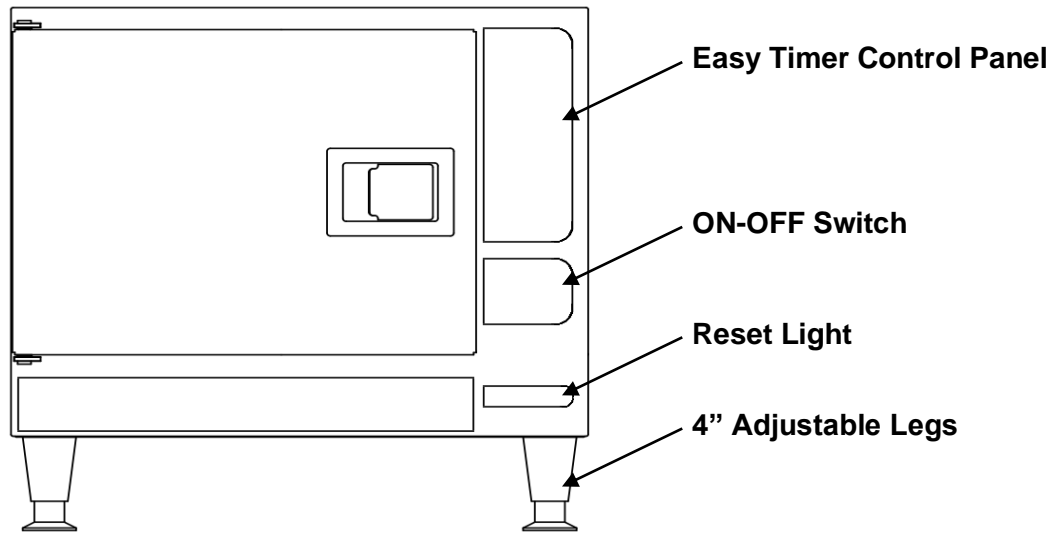
### C. Product Information Plate

The Product Information Plate on the side opposite the control panel lists the:

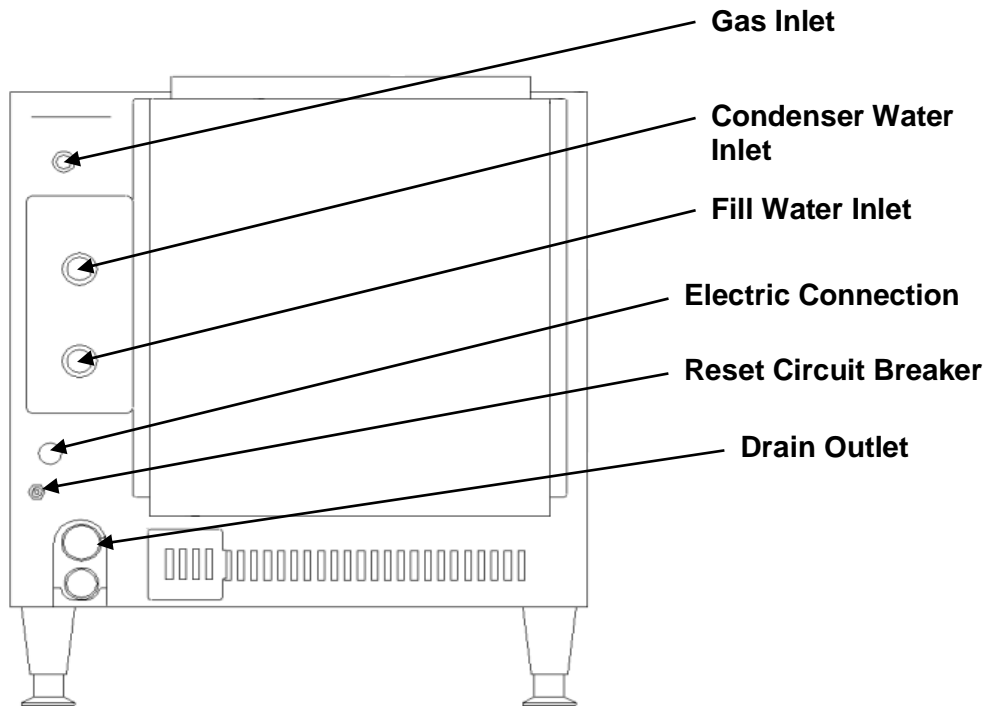
- Model
- Serial number
- Gas
- Electric
- Wiring requirements

### D. Product Views

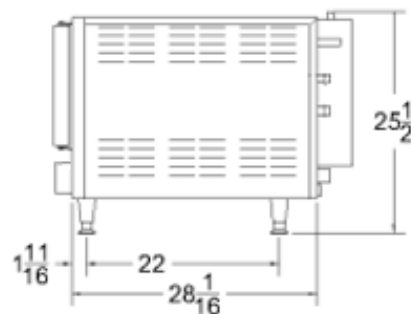
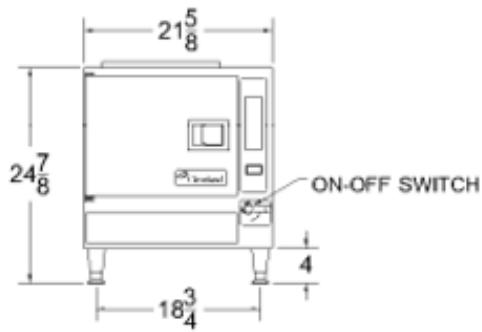
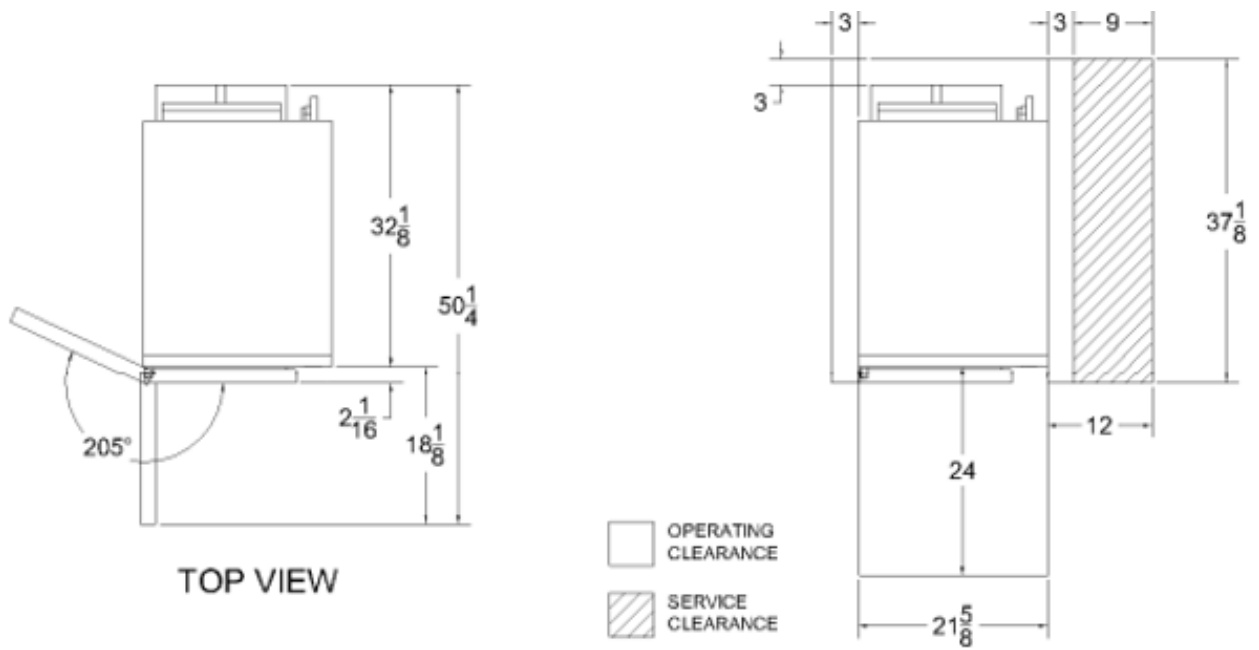




**Figure 2-1 SteamChef™ Steam Cooker Front View  
(Model 22CGT3.1 Shown)**



**Figure 2-2 SteamChef™ Steam Cooker Rear View  
(Model 22CGT3.1 Shown)**



Note: Height of 22CGT6.1 is  $34\frac{3}{4}$

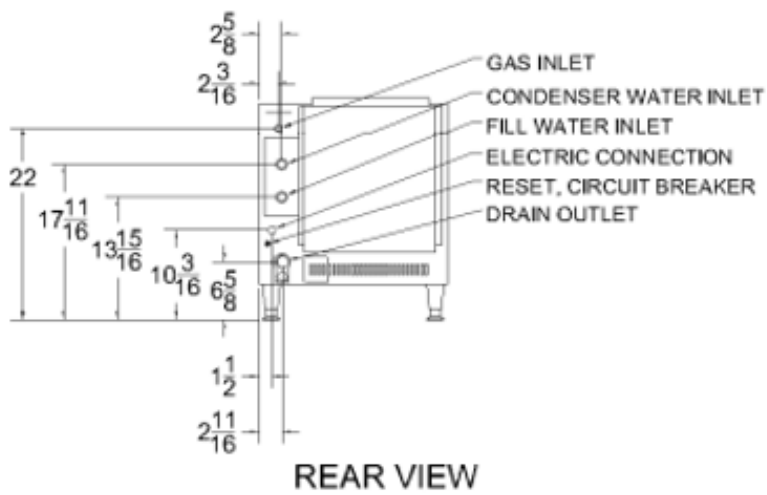


Figure 2-3 Dimensions and Clearances  
(Model 22CGT3.1 & 22CGT6.1 Shown)

## CHAPTER 3 INSTALLATION PROCEDURE

### DANGER

Operating this appliance out of level can cause DEATH, INJURY, and EQUIPMENT DAMAGE. This appliance must be level both front-to-back and side-to-side in all installations.

NEVER operate this appliance out of level.

If this appliance is suspected to be out of level, shut it down at once and call your qualified Cleveland Range authorized service agency immediately.

#### A. Select a Location

For safe and efficient operation:

1. Installation must comply with all local fire and health codes.
2. The location selected must be capable of supporting this appliance.
  - The operating weight of a 22CGT3.1 is 310 pounds and a 22CGT6.1 is 360 pounds.
3. Position the appliance so it will not tip or slide.
4. The operating surface must be level enough to allow leveling with the adjustable legs. This appliance **MUST** be level both front to back and side to side before operation.
5. A suitable drain must be available within 12 feet of this appliance. Do NOT install the appliance directly over a drain.
6. The location must include space for Operating and Service/Secondary Clearances and the Exhaust Hood. See Figure 2-3.

### WARNING

All clearance requirements above, below, and around this appliance are the same for non-combustible locations as for combustible locations.

Failure to maintain required clearances and additional distances as needed can result in INJURY and EQUIPMENT DAMAGE.

Consult manufacturers' literature, and sales and service agencies as needed.

7. KEEP THE APPLIANCE AREA FREE AND CLEAR OF COMBUSTIBLES.
8. Proper air supply for ventilation is REQUIRED for and CRITICAL to safe, efficient operation of this appliance.
9. Make sure the air vents of this appliance are not blocked with or by anything.
10. Allow for sufficient extra distance if a "high heat source," e.g., a broiler, is located next to this appliance. Contact Cleveland Range for recommendations.
11. Do NOT install this appliance directly over a drain. Steam rising up out of the drain will adversely affect operation, hamper cooling air circulation, and damage electrical and electronic components.

#### B. Exhaust Hood Requirements

1. A gas fired SteamChef Oven must be installed under a suitable ventilation hood as required by the National Fuel Gas Code, ANSI Z223.1/NFPA 54. The venting hood system must also include an interlock to prevent the operation of this appliance without the operation of the ventilation hood.
2. The exhaust hood must extend over the gas flue opening and meet the following requirements:
  - a) The SteamChef must be vented in accordance with all local, state and national codes for venting gas fired appliances.
  - b) The exhaust hood must be sized for the cumulative ventilation requirements of all the gas-fired appliances in the area under the hood, including the SteamChef.
    - The BTU/HR for a 22CGT3.1 and 22CGT6.1 is 32,000.
  - c) If an existing hood does not meet all specifications, a new one must be constructed over the SteamChef.

d) When determining hood size, include operating clearances. See Figure 2-3.

### C. Lifting Points

#### Do NOT Lift from Sides

- Lift as shown from front or back.
- Place lift truck forks or lifting straps BETWEEN the 4" legs.
- Do **NOT** lift from the sides. Lifting from the sides will damage the SteamChef and void the Warranty.
- See Chapters 2 and 3 for lifting warnings and appliance weights.

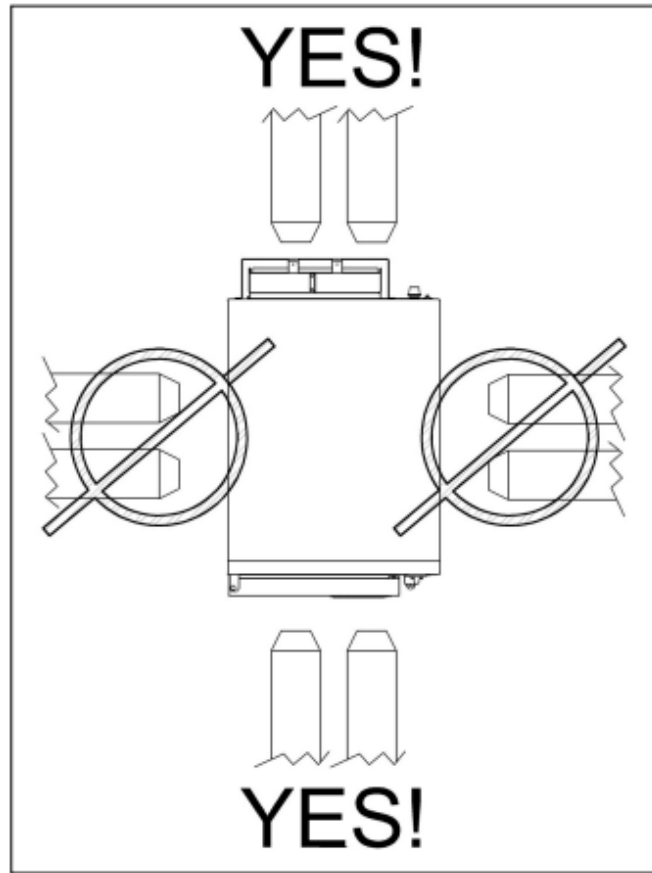


Figure 3-1 Do **NOT** Lift from Sides

### D. Install the Legs

1. The legs on the SteamChef must be used for installing the appliance, unless it is installed with a Cleveland Range stacking stand. See the instructions included with the stand.
2. To safely assemble the legs onto the appliance without damaging it, the following assembly procedure should be used.
  - a) Check that the feet are fully retracted into the legs. Do not over tighten. The feet should easily screw in and out using fingers only.
  - b) Remove the four foam packing blocks from the upper packing assembly and position them on a flat surface (such as the floor) in the pattern shown in Figure 3-2.
  - c) Center the SteamChef™ on the blocks as shown in Figure 3-2.
  - d) Screw the four legs into the weld nut mounting holes. All four legs must be installed for proper installation of a SteamChef™.
  - e) The appliance is now ready to be moved to its final location. Lift the appliance off the blocks and move it to its final location. Do **NOT** lift from sides. See Figure 3-1.
  - f) Discard the foam packing blocks.

## ⚠ DANGER

Improper lifting can result in DEATH, INJURY, AND EQUIPMENT DAMAGE.

Use enough workers with training and experience lifting heavy equipment to place SteamChefs on supporting surfaces, and to lift and to move SteamChefs and accessories.

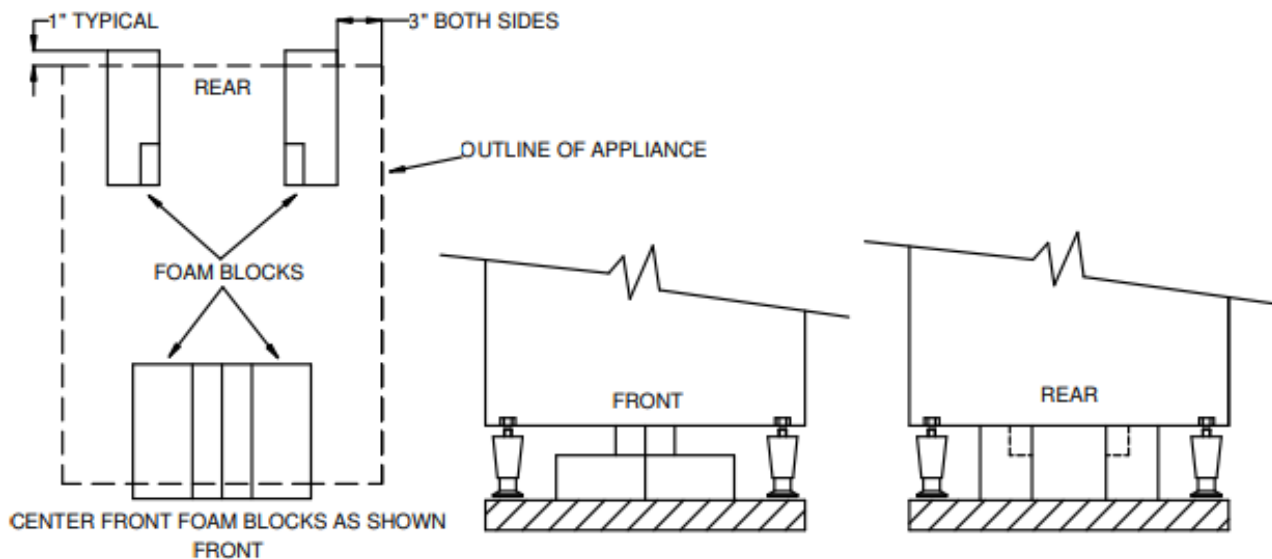


Figure 3-2

### SteamChef on Foam Packing Blocks, Top, Front, and Rear Views

#### E. Position and Level the SteamChef

1. Move the SteamChef into position.
2. Place a level along the bottom edge of the SteamChef.
3. Use the adjustable legs of the SteamChef or the adjustable legs of the Cleveland Range stand to level the SteamChef front-to-back and side-to-side.

#### F. Gas Supply for the SteamChef

## ⚠ DANGER

Gas leaks are fire and explosion hazards. INJURY, DEATH, and PROPERTY DAMAGE will result.

If the installer smells gas, or suspects there is a gas leak, immediately refer to the posted gas leak instructions. The posted instructions are provided by the local gas supplier and supersede any other instructions.

#### 1. Gas Supply Requirements

- Gas supply type MUST match the type of gas shown on the rating plate.
- Gas supply pressure must NOT exceed 14" water column (1/2 psi) and fall within the acceptable pressure range shown below when using 3/4" NPT line and a 1/2" NPT connection.
- Natural gas pressure at 1000 BTU/CF must be between 7" – 14" water column.
- If the gas supply pressure exceeds 14" water column, a pressure regulating valve (pressure regulator) must be installed in gas supply plumbing to reduce pressure to the SteamChef. See Figure 3-3.

#### 2. Installation of the Gas Supply Lines

The Installer / owner is responsible for furnishing and installing gas supply lines, valves, regulators, and accessories.

When installing gas supply lines and accessories, observe the following:

- a) Refer to Figure 3-3 for the recommended layout of the gas supply lines.
- b) Use a non-hardening pipe thread sealant resistant to LP gas.
- c) The ½" NPT gas inlet is on the back of the SteamChef. See Figure 2-2.
- d) Install main manual shut off valve between gas supply and the SteamChef. See Figure 3-3. This main manual shut off valve is called the "Main Manual Gas Valve."
- e) Install a sediment trap (drip leg) in gas supply line. See Figure 3-3.

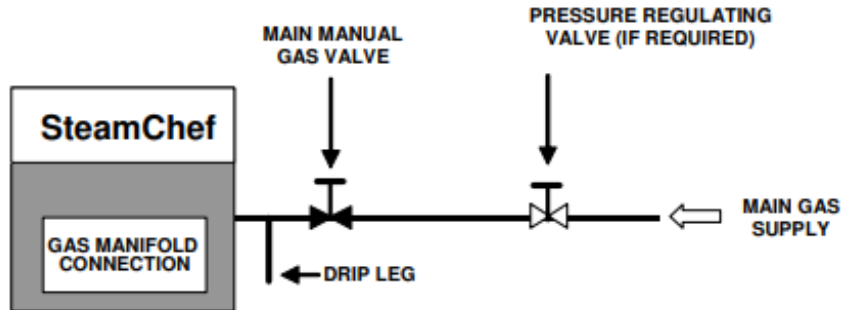


Figure 3-3 Gas Supply Line Layout

### 3. Testing Gas Supply Lines

- 1) Test all pipe joints for leaks with soap and water solution.
- 2) Check all connections for proper tightness.
- 3) Remove the control side panel to inspect gas connections inside the SteamChef.
- 4) Open the gas supply valves.
- 5) Check all lines and connections for leaks, both inside and outside the SteamChef.
- 6) All leaks must be corrected before attempting to operate the SteamChef.
- 7) Replace the side panel and secure it to the SteamChef before starting the SteamChef.

### 4. Pressure Testing Gas Supply Lines

If any pressure testing is required, the SteamChef must be disconnected or isolated from the gas supply piping system during any pressure testing as follows:

- The appliance and its main manual shut-off valve must be **disconnected** from the gas supply piping system during any pressure testing of the system at test pressures in excess of 14" water column (1/2 psi or 3.45 kPa).
- The appliance must be isolated from the gas supply piping system by closing its main manual shut-off valve during any pressure testing of the gas supply piping system at test pressures equal to or less than 14" water column (1/2 psi or 3.45 kPa).

## G. Water Connections for the SteamChef

### 1. Water Supply Quality Requirements

## NOTICE

Using water outside the limits specified in the Warranty without appropriate adjustment in the maintenance schedule voids warranty coverage.

- a) Contact your Cleveland Range sales representative for details on how to provide water per Minimum Water Quality Requirements in the Warranty, or how to increase the frequency of maintenance, cleaning, and descaling.
- b) Poor water supply quality degrades SteamChef performance.
- c) Check the quality of supply water before designing the water supply by contacting a local water treatment specialist for on-premises water analysis.

- d) Softened or chlorinated water damages the water reservoir by increasing corrosion. Carbon type filters are required before water enters the water reservoir if supply water is softened or chlorinated.
- e) If a water treatment system must be installed to achieve acceptable water quality, install it **BEFORE** connecting the water supply lines to a SteamChef.
- f) If analysis shows that supply water is below Minimum Water Quality:
  - **EITHER** a water treatment system and/or carbon filter must be installed in the line feeding the water reservoir,
  - **OR** the frequency of maintenance, cleaning, and descaling must be increased beyond that recommended in the maintenance schedule.

## 2. Connection of the Water Supply Lines

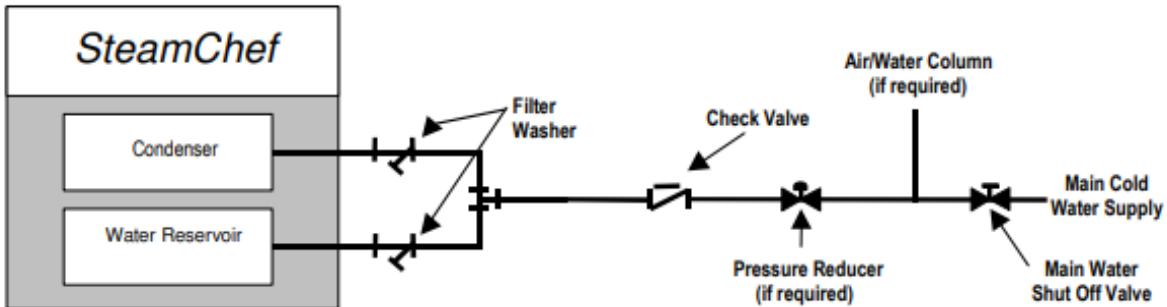
- The Installer/Owner is responsible for the correct water connection of the SteamChef.
- When connecting water supply lines observe the following instructions, and any and all other applicable national, state, and local codes and regulations.
- **NOTICE: Connect the SteamChef to COLD WATER!**
- **Never** connect the SteamChef to HOT WATER! The Condenser and the water reservoir system will not work properly if connected to HOT or WARM water.
  - a) **The water supply must have a minimum dynamic (flow) pressure of 35 psi (2.4 kg/cm<sup>2</sup>) and a maximum static pressure of 60 psi (4.1 kg/cm<sup>2</sup>).**
  - b) **If the static pressure is above 60 psi, a pressure regulator must be used and set at approximately 50 psi. Pressure above 60 psi can damage solenoid valves.**
- c) SteamChefs have two connection points for incoming water: condenser, and water reservoir fill.
- d) If the water supply meets requirements shown in the Warranty, then the Single Water Supply Arrangement shown in Figure 3-5 may be used.
- e) If the water supply fails to meet the requirements shown in the Warranty, then use the Separate Water Supply Arrangement shown in Figure 3-6.
- f) Installation Requirements:
  - i. Apply non-hardening pipe sealant to all the threaded connections **except** the 3/4" GHT (Garden Hose Thread or National Hose Thread) connections at the Water Connection. GHT or NHT connections do not require pipe sealant.
  - ii. Install a manual water shut-off valve (not provided) between main cold water supply line(s) and SteamChef supply lines.
  - iii. The National Sanitation Foundation (NSF) requires installation of a check-valve (or other approved anti-backflow / anti-siphon device) (not provided) in all supply lines in accordance with and as required by local, state, and national health, sanitation, and plumbing codes.
  - iv. Check local codes to determine exactly what type of anti-backflow / anti-siphon device is necessary to meet local requirements.
  - v. Cleveland Range recommends the plumbing layout in either Figure 3-5 for installations using a single water supply or Figure 3-6 if a separate conditioned water supply is used for the water reservoir feed.
    - Use two (2) 3/8" supply lines for a separate conditioned water supply.
    - Use one (1) 1/2" supply line for a single water supply. Use the Single Point Water Connection Kit (cold water supply splitter) (P/N 111009).
  - vi. The SteamChef has two 3/4-inch NHT fittings (National Hose Thread or Garden Hose Thread) for the water connections to the water reservoir and to the condenser.

**NOTE:** The hose connector used must be NSF or FDA rated for food grade service.

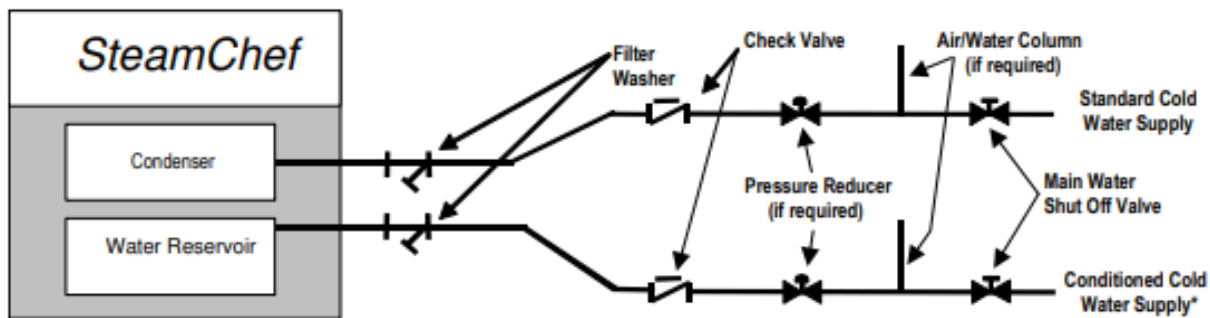
- vii. Construct all supply lines up to the point of installing the filter washer.
- viii. Flush the water supply lines before connecting them.
- ix. A Filter Washer is supplied installed in each of the water inlets of this SteamChef (See Figure 3-4, Cleveland Range Part Number 110987.)
  - Remove the water supply shipping cap. The filter washer is under the shipping cap.
  - Make sure the filter washer is properly in place, and connect the water supply to the SteamChef.



**Figure 3-4  
Filter Washer  
(P/N 110987)**



**Figure 3-5 Cleveland Range Single Water Supply Arrangement**



**Figure 3-6 Cleveland Range Separate Water Supply Arrangement**

“Conditioned” indicates water that has been filtered or treated by a Cleveland Range approved method to meet or exceed the water quality standards in the Warranty.

### 3. Test Water Supply Lines

- a) Make sure the Main External Power Switch is OFF.
- b) Check all connections for proper tightness.
- c) Remove the control side panel to inspect water connections inside the SteamChef.
- d) Open the water supply valves.
- e) Check all lines and connections for leaks, both inside and outside the SteamChef.
- f) Correct any leaks.
- g) Replace the side panel and secure it to the SteamChef before starting the SteamChef.

### H. Electric Connections for the SteamChef

1. Check the rating plate to make sure the SteamChef is compatible with the local electric supply.
  - The rating plate is located on the side panel OPPOSITE the control side.
  - The electrical diagram and the spare parts list are on the side panel on the control side.



- The main terminals are behind the control side panel in the service connection area.
2. The electrical supply must match all electrical and wiring requirements specified on the rating plate and the connection must be made in accordance with the following requirements:
    - a) The SteamChef must be properly grounded by the installer.
    - b) The electrical power lines must be installed in accordance with:
      - The National Electric Code, ANSI/NFPA No. 70 LATEST EDITION (USA).
      - Canadian Electrical Code, CSA C22.2.
      - Any other applicable national, state, or local laws, codes, and regulations.
  3. A main external disconnect switch should be installed near the SteamChef as shown in Figure 3-7.
    - A separate fuse or breaker sized to meet the line amps required by the SteamChef should be installed either as part of the main external power switch or in a separate fuse box.
    - The fuse or breaker and disconnect switch combination is called the “Main External Power Switch.” See Figure 3-7.
    - This appliance is not suitable for connection to a power cord. Do NOT use a power cord.
    - This appliance is not suitable for connection to a GFCI (GFI). Do NOT use a GFCI (GFI).
  4. Remove the control side panel.
  5. Make the electrical connection using sufficient length of flexible conduit, per local code, so the SteamChef can be moved for service.
  6. Mechanically secure the flexible conduit to the SteamChef’s electrical access hole.
  7. Check all cable and wire connections for size, location, and tightness.
  8. Replace the control side panel and secure it to the SteamChef before starting the SteamChef.

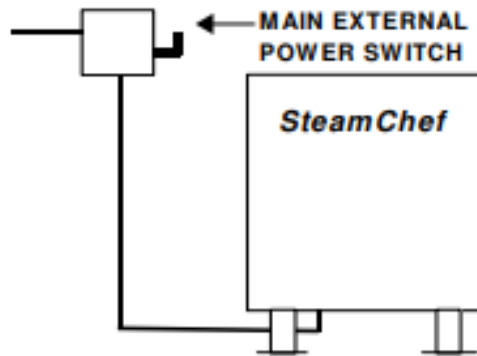


Figure 3-7 Main External Power Switch

#### I. Install the Free Air Vented Drain Line

### ⚠ DANGER

DEATH, INJURY, EQUIPMENT and PROPERTY DAMAGE will result from improper installation of drain outlet lines.

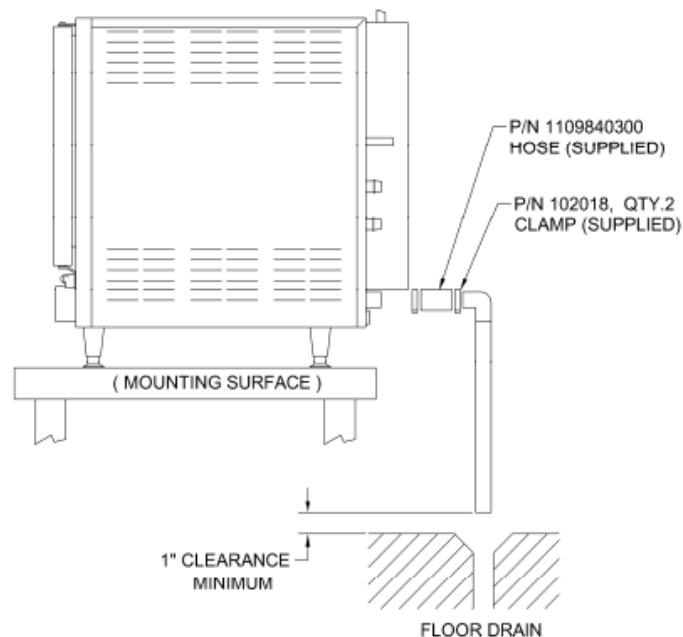
Install free air vented drain lines as described in this manual.

**NOTICE:** Furnishing and installing drain lines and drainpipe is the responsibility of the Owner/Installer.

**NOTICE:** Improper installation of drain outlet lines voids the SteamChef Warranty.

**The following restrictions and requirements are critical to the safety of personnel and equipment, and must not be violated under any circumstances:**

1. The drain lines must be installed in compliance with the Food Code (latest edition) of the Food and Drug Administration (FDA), and any other applicable national, state, or local codes and regulations.
2. The drain line must be free air vented, have gravity flow from the SteamChef, and terminate outside the perimeter of the SteamChef.
3. Free air venting requires a minimum of 1" clearance between the end of the drain line and the top of the floor drain. See Figure 3-8.
4. Do NOT install the SteamChef directly over a drain. Steam rising up out of the drain will adversely affect operation, hamper cooling air circulation, and damage electrical and electronic components.
5. Do NOT connect the SteamChef drain connection to any drain material that cannot sustain 140°F.
6. Do NOT connect drains from any other equipment to the drain line of the SteamChef.
7. Do NOT connect the drain outlet extension line directly into a floor drain or a sewer line.
8. Do NOT connect the SteamChef drain directly to drains or to the plumbing of any other equipment.
9. Do NOT install a trap or shutoff in the drain line.
10. The total length of pipe and number of bend fittings required to reach the open drain determines the pipe size used to extend the drain line to an open drain.
  - Do NOT make a drain outlet extension more than 12 feet long.
  - If the drain outlet extension requires 6 feet or less of pipe, and no more than two elbows are required, 1 ½-inch pipe and fittings are acceptable.
  - If the drain outlet extension requires 6 to 12 feet of pipe, or requires three elbows, then 2-inch pipe and fittings are required.
11. Refer to Figure 3-8: Connect the drain.



**Figure 3-8 Typical Drain Layout**

#### **J. Install the Fan Guard and Air Diverter**

**NOTE:** See Figure 3-9.

1. To Install the fan guard and air diverter:
  - a) Hold the fan guard so that the large ends of the keyholes are towards the bottom of the SteamChef.
  - b) Place all four openings over the mounts located on the rear wall of the SteamChef.

- c) Pull it down so that the narrow ends of the slots are pulled tight over the mounts. See Figure 3-8.
- d) Place the air diverter over the fan guard. Press lightly towards the rear wall until the air diverter drops into its slots in the fan guard.

#### K. Install the KleanShield™

**NOTE:** See Figure 3-9.

Never operate a SteamChef without a properly installed KleanShield™.

1. Place the KleanShield™ into the SteamChef so the drain trough slips into the KleanShield™ drain at the rear of the cooking compartment.
2. Carefully lower the front of the KleanShield™ so the Water Level Sensor Guard is behind the probes and the front legs rest on the bottom of the cooking compartment.

### ⚠ WARNING

The fan guard helps protect the operator from injury caused by the rotating fan blades.

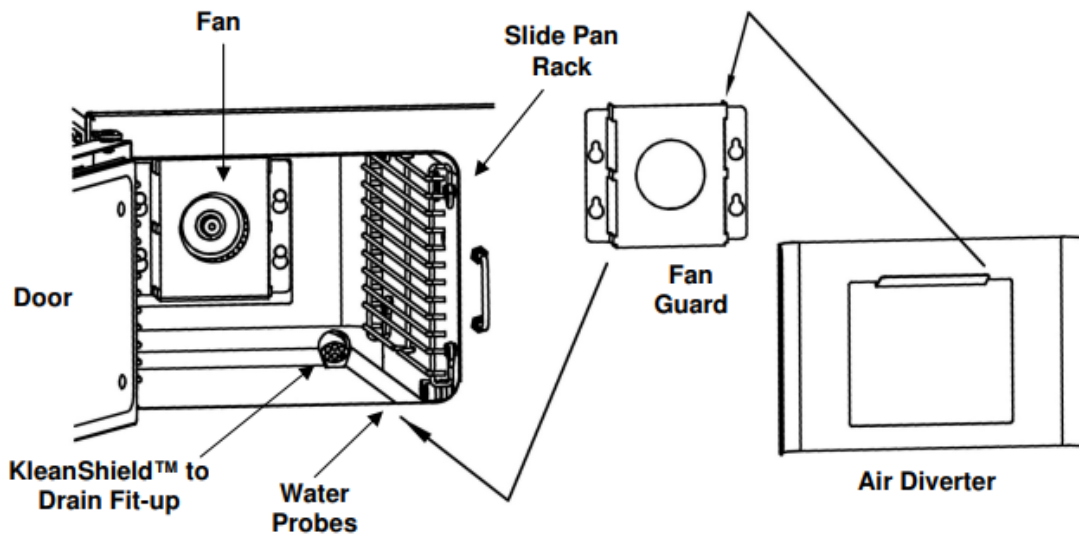
Never operate a SteamChef without the fan guard properly installed.

Operating a SteamChef without the fan guard properly installed can cause INJURY, EQUIPMENT DAMAGE, and REDUCE PERFORMANCE.

#### L. Install the Slide Racks (Pan Racks)

**NOTE:** See Figure 3-9.

1. Each slide rack has four loops: two at the top and two at the bottom. Hold the slide rack so the ends of the hanger loops are towards the cooking compartment wall, as shown in Figure 3-8.
2. Slide one rack into the compartment with the hanger loops on the cooking compartment wall side.
3. Hook the loops over the top and bottom pins.
4. Repeat steps 1. through 3. for the other rack.



**Figure 3-9**  
**Cooking Compartment**

**M. Installation Check List**

**Installation Check List**

	TASK	REFERENCE	COMPLETED
Preparation	Check Operating Location Clearances	Chapter 2 Section D	
	Test Supply Water Quality	Chapter 3 Section G	
	Verify Electric Power Requirements	Chapter 3 Section H	
	Verify Gas Supply Requirements	Chapter 3 Section F	
	Verify Exhaust Hood Requirements	Chapter 3 Section B	
Installation	Verify SteamChef is Level	Chapter 3 Section E	
	Check Exhaust Hood Function	Chapter 3 Section B	
	Check Electrical Supply Connection	Chapter 3 Section H	
	Check Water Supply Connection	Chapter 3 Section G	
	Leak Test Water Supply Lines	Chapter 3 Section G	
	Check Gas Supply Connection	Chapter 3 Section F	
	Leak Test Gas Supply Connection	Chapter 3 Section F	
	Check Drain Line Connection	Chapter 3 Section I	

## CHAPTER 4 COOKING WITH THE SteamChef

### DANGER

Do NOT breathe steam, hot air or condensate. DEATH or INJURY will result.

### WARNING

**Hot air, steam, and condensate will cause burns and scalds.**

To help prevent burns and scalds when opening steamer doors: always stand to the hinge side and back from the doors, slowly open the door, and wait for the steam and heat to dissipate before reaching into the steamer.

**The SteamChef Steamer is a continuously operating appliance, so parts are ALWAYS HOT when the Main External Power Switch or the ON/OFF switch is in the ON position.**

When the ON/OFF switch is turned to the OFF position, the SteamChef will remain HOT for some time. Contact with hot surfaces and steam can cause burns and scalds. Avoid contact with hot surfaces and steam.

**If the steamer door is stuck shut: DO NOT force the door open.**

The door stuck shut may indicate a blocked drain. Hot water can fill the cooking compartment and spill out if the door is forced open causing injury and equipment damage.

If the SteamChef door is stuck shut:

- Turn OFF the steamer.
- Call a qualified Cleveland Range authorized service technician.
- Wait for the steamer to cool before servicing.

### CAUTION

**Some foods drip juices.** Use a solid catch pan under perforated pans when cooking food that drips juices. Dripping juices can cause burns and clog the drain and KleanShield™.

Do NOT use oven racks that are bent or otherwise damaged in any way.

DO Insert pans and accessories LEVEL and INSIDE the oven racks.

Pans and accessories placed in damaged or out of level racks, or outside racks can tip and spill, causing burns, injuries and/or equipment damage.

#### A. Operating and Cooking Procedure – All Models

**NOTE:** The condenser water does not flow until the cooking compartment reaches the minimum cooking temperature to reduce steam loss and condenser water use.

If condenser flow starts before the cooking compartment reaches cooking temperature, turn OFF the steamer and call your qualified Cleveland Range authorized service representative.

##### 1. Before Cooking or Rethermalizing

- a) Inspect the cooking compartment, drain, KleanShield™, and clean as required BEFORE turning ON the SteamChef. It will be too hot to inspect and clean safely after turning ON. See Chapter 6.
- b) Turn ON and fill the SteamChef. See Chapter 5.
- c) Preheat the cooking compartment. See Chapter 5.
- d) Slide the pans of food into the slide racks inside the SteamChef. Do not place pans or anything else on the bottom of the compartment or on the KleanShield™.
- e) For best results, use 2-1/2-inch-deep, perforated pans without covers. These give the best heat transfer and shortest cooking time.
- f) Close the cooking compartment door.

2. Refer to **Easy Timer Operating Instructions** in Chapter 5 to start cooking.
  - While cooking, occasionally check the water in the reservoir for food particles and oils. If the water is dirty or cloudy, change the water. See Chapter 8.
  - The steamer compartment of the SteamChef Steamer is equipped with an automatic **door interlock switch** that turns off the heating elements and shuts off the convection fan and condenser when the door to the compartment is opened.

## **WARNING**

### **Burn and Scald Hazard**

Even though the heat shuts off as soon as the door is opened, it may take up to a minute for production of steam to end and residual steam in the system to clear from the cooking compartment.

To help avoid injury, always wait until the residual steam clears and the convection fan stops before reaching into the cooking compartment, and always wear dry heatproof gloves when reaching into the cooking compartment. Wet or damp gloves conduct heat and can cause burns when touching hot items.

3. After Cooking or Rethermalizing
  - a) Carefully open the cooking compartment door and remove the pans from the slide racks.
  - b) If the SteamChef will not be used again, perform the **Cleaning Procedure** in Chapter 6.

### **B. Rethermalization:**

- The SteamChef may also be used to reheat/re-thermalize previously cooked and/or refrigerated foods to serving temperature.
- Depending on initial food temperature and density, most foods will rethermalize to their safe serving temperature in 10 to 40 minutes.
- Always check internal temperature of food with a thermometer to determine that it has been rethermalized to its safe serving temperature.

## CHAPTER 5 EASY TIMER OPERATING INSTRUCTIONS



DIGITAL DISPLAY

**CONTROL KNOB**  
Enabled with **TIMED** mode  
Disabled with **MANUAL** mode

**TIMER START/STOP BUTTON** in **TIMED** mode

**TIMED/MANUAL SWITCH BUTTON**  
(Press for 5 sec)



ON-OFF SWITCH

### **⚠ CAUTION**

Press switch and button with fingertips only.

INJURY and EQUIPMENT DAMAGE can result from pressing switches and buttons with anything else.

### A. Main External Power Switch

Usually, the SteamChef's Main External Power Switch is left ON during operating hours. If the Main External Power Switch is OFF, turn it ON as follows:

1. Turn the ON/OFF switch to the OFF position.
2. The control panel settings are not important in this procedure. The control panel circuits are not powered while the ON/OFF switch is OFF.
3. Refer to Figure 5-1 and turn on electric power to the SteamChef at the Main External Power Switch.

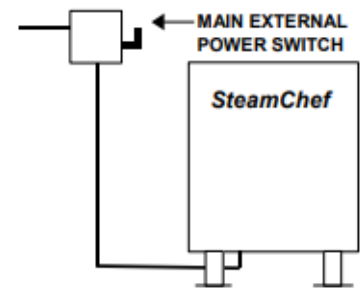


Figure 5-1

Main External Power Switch

### B. To Inspect the Cooking Compartment

1. Before turning ON the power switch to the SteamChef, the inside of the SteamChef must be clean. See Chapter 6.
2. Inspect the door gasket assembly, water level sensors, KleanShield™, drain screen, fan guard, air diverter, and slide racks for proper installation and cleanliness. See Figure 5-2.
3. Make sure that the KleanShield™ drain is clear. If the drain is blocked or slow, do NOT start the SteamChef until it has been cleaned. See Chapter 6 for Cleaning and Troubleshooting procedures. To check the drain:
  - a) Pour about a quart of water through the KleanShield™ drain.
  - b) Check that the water flows out the drain and drainpipe.

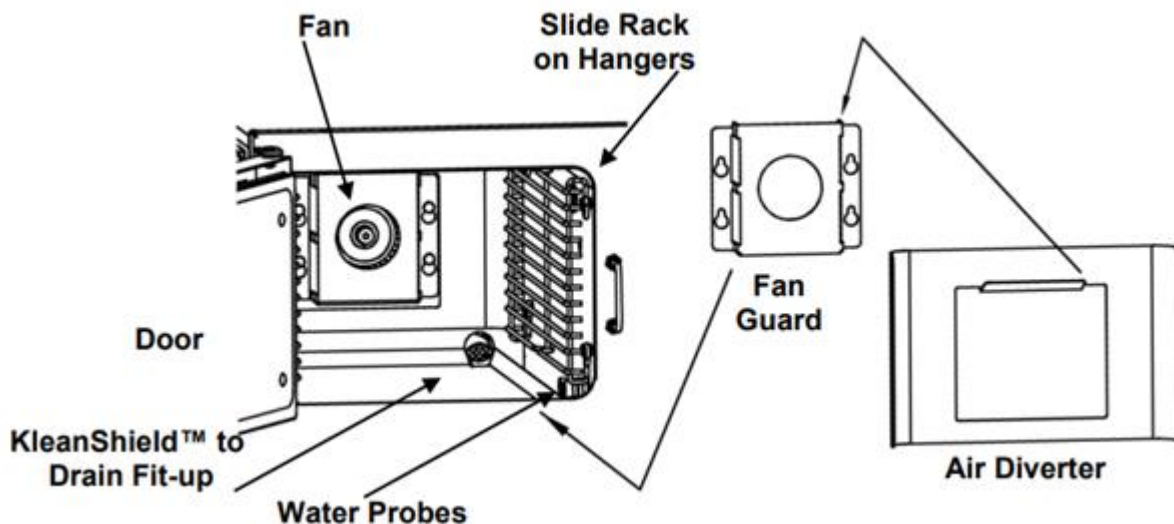


Figure 5-2

Cooking Compartment

### C. Power ON (Automatic Water Fill / Automatic Preheat)

1. Open the water supply valves to the steamer
2. Turn ON power to the SteamChef by turning ON the (POWER SWITCH).
3. The power ON indicator lights and the SteamChef reservoir fills.
4. Timed Mode (with "SURE COOK" mode feature)
  - a) Select cooking time using "Control Knob".
  - b) Press "TIMER-START/STOP" button to start cooking.
  - c) "SURE COOK" illuminates on digital display once the compartment reaches 193°F (90°C).
  - d) Timer then starts to countdown until it reaches 00:00.
  - e) Steamer will stop heating and require prompt when the timer reaches 0:00.
5. Manual Mode (Continuous Steaming)



- a) Press and hold “TIMER-START STOP” button for 5 seconds until switches to Manual mode.
  - b) “MAN” will appear on the digital display when activated and control knob disabled.
  - c) **NOTE:** steamer will go into “Standby” mode if compartment isn’t opened for 60 minutes.
6. Changing from Manual to Times Mode
- a) Press and hold “TIMER-START/STOP” button for 5 seconds until switches to TIMED mode.
  - b) “TIMED” will appear on the digital display.
  - c) Digital display will display 00:00, Control knob activated.
7. “Delime” Notification
- a) Easy Timer comes with 400 hours operation for “Deliming Notification.”
  - b) After 400 hours, “DELIME” appears on digital display for 5 seconds and will re-appear every 5 minutes.
8. Reset and Clear Delime Notification
- a) Turn OFF main power with POWER SWITCH
  - b) Press and hold the “TIMER-START/STOP” Button
  - c) Power unit ON with main POWER SWITCH (with “TIMER START/STOP” Button held).
  - d) Wait 10 seconds to Reset/ Clearing Mode.
  - e) The Beeper starts beeping once every second.
  - f) Release the “TIMER-START/STOP” button.
  - g) Display will show “RST”.
  - h) Press the “TIMER-START/STOP” button to confirm resetting delime notification.
9. Program Number of Hours until Delime Notification
- a) Turn OFF main power with POWER SWITCH.
  - b) Press and hold the “TIMER-START/STOP” Button.
  - c) Power unit ON with main POWER SWITCH (with “TIMER START/STOP” Button held).
  - d) Wait 20 seconds to enter Programming Mode (to change the Max number of hours)
  - e) The Beeper starts beeping twice every second.
  - f) Release the “TIMER-START/STOP” button.
  - g) Display will show past settings.
  - h) Turn knob to adjust the number of hours.
  - i) Press “TIMER-START/STOP” button to save number of hours for next delime notification.

#### D. Lighting and Shutdown Instructions (Normal Operation)

1. Lighting and Shutdown Instructions for Normal Operation

### **⚠ DANGER**

#### **DO NOT TRY TO LIGHT BURNERS WITH A FLAME.**

The SteamChef has an electronic ignition system, which automatically lights burners, senses the flame, and controls gas flow. This provides precise burner control, safe ignition, and safe shutdown.

DEATH, INJURY, OR EQUIPMENT DAMAGE may result from trying to light burners with a flame or from an improperly adjusted gas control and ignition system. Do not try to light burners with a flame. Do not alter any gas control adjustments.

If adjustment is required, contact a Cleveland Range authorized service center. Cleveland Range is in no way responsible for the operation or safety of this equipment if the controller, valve, igniter probe or any other gas system component is adjusted by anyone other than a qualified Cleveland Range authorized service representative.

The following START-UP SUMMARY is for quick reference ONLY. For safe operation and use of this equipment, the operator must comply with all safety and operating instructions in this manual.

### **Lighting Instructions**

1. Close the cooking compartment door.
2. Turn the ON/OFF switch clockwise to the ON position.
  - Reservoir will fill with water (about 1 minute).
  - Spark will initiate, and main gas valve will open for 4 seconds.
  - If the unit fails to light within 4 seconds, gas valve will close, and lockout and a continuous buzzer will sound.
3. System may be reset manually by turning the on/off switch off for 5 minutes and back on.

### **Shut Down Instructions**

1. Turn off the ON/OFF switch.
2. Wait for the 3-minute drain rinse cycle to run.
3. Turn off the main external power switch.

## **E. Turn Off the Main Manual Gas Valve**

### **Preheat Steamer**

- Preheat steamer to ensure productivity and consistency. BEFORE PREHEATING: Inspect and clean the compartment. After preheating, the compartment will be too hot to inspect and clean safely.
- To preheat the SteamChef Steamer:
  1. Close the steamer door and turn the steamer ON 15 minutes before cooking.
  2. The Steamer will heat to the standby temperature.

## **F. High Limit Reset**

This steamer has a high limit lockout to protect the unit from overheating.

### **If the high limit lockout temperature is reached:**

1. The RESET light will turn ON.
2. A buzzer will sound continuously.
3. The heater will shut OFF.
4. The steamer must be reset before cooking can continue.

### **To reset the high limit:**

1. Turn OFF power to the steamer with the ON/OFF switch.
2. Wait 15 minutes for the steamer to cool.
3. Make sure the water probes are clean. See Chapter 6.
4. Refill with water and restart according to the Power ON instructions.
5. If the problem repeats, see the **Operators Troubleshooting Guide**. See Chapter 9.

## CHAPTER 6 SHUTDOWN AND CLEANING PROCEDURE

### **⚠ WARNING**

**The steamer stays hot for a long time.** To help avoid burns, allow the steamer to cool completely before cleaning or servicing.

**Do NOT use hoses, power cleaners, or pressure washers on or in the SteamChef Steamer.** Doing so can cause electric shock and/or damage electrical and electronic components.

**A clogged or slow drain can cause hot water to collect in the oven compartment and spill out when the door is opened causing injury and equipment damage.**

Never push food debris or scale down the steamer drain, or through the KleanShield™ opening. Debris and scale can build up in the drain system and clog or slow the drain and lead to additional maintenance and service problems.

Always remove any solid matter from the inside of the steamer with a rag or spatula before rinsing cleaning water down the drain.

### **⚠ WARNING**

**When cleaning: do NOT pick up or tilt the SteamChef.** If it is necessary to move a SteamChef for cleaning, turn OFF power at the Main External Power Supply and at the ON/OFF switch to drain the water from the SteamChef.

**INJURY and EQUIPMENT DAMAGE can result from shifting the SteamChef out of level while the power is ON at the Main External Power Supply and/or water is in the SteamChef.**

The steamer **MUST BE LEVEL BOTH FRONT TO BACK AND SIDE TO SIDE** in all mounting arrangements before operation. Check level front to back and side to side before restoring power as described in the Installation Manual after moving the SteamChef.

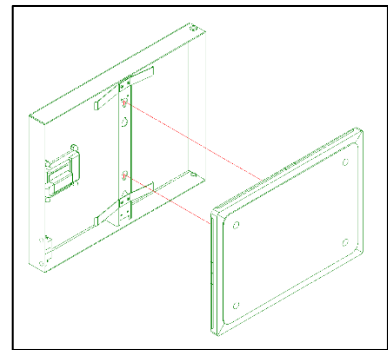
This procedure should be performed at the end of each day or shift, or more frequently if the water supply does not meet the Minimum Water Quality Requirements in the Warranty.

1. Turn the ON/OFF switch to OFF to de-energize all controls and drain the steamer. The appliance will begin a 3-minute drain rinse cycle to clean the drain system.
2. Open the cooking compartment door and allow steamer to cool.
3. Remove any spilled food from the surface of the KleanShield™.
  - Never push food scraps down the KleanShield™ opening or the reservoir drain opening.
4. Remove the slide racks, fan guard and KleanShield™. Wash and rinse slide racks, fan guard and KleanShield™ separately or clean them in a dishwasher according to health requirements.
5. Remove any spilled food from inside compartment and clear any residue from the drain valve and the KleanShield™ drain opening.
  - Do not push food debris or scale down the steamer drain, or through the KleanShield™ drain.
6. Clean the interior of the compartment thoroughly, removing all food particles and scale from the steamer.
7. Wipe down the interior of the cooking compartment with a half water and half white household vinegar solution. Use a spray bottle of the same vinegar solution to rinse the convection fan located at the back of the cooking compartment.
  - When done daily this will help prevent the buildup of calcium and other mineral deposits left over from the boiling of water, and prevent scale buildup in the steamer, helping prevent more costly maintenance and service on the steamer.
  - Cleveland Range does not recommend the use of detergent, but if detergent has been used to clean the inside of the steamer, be sure to rinse off the probe assembly with the vinegar solution. If detergent residue is not completely rinsed from the probe assembly, then the residue can prevent the water level control from operating.
8. Use a soft bristle brush to clean the water sensor, temperature probe, and fan and to remove stubborn food

particles.

9. Do not use abrasive cleaning compounds or steel wool.
10. Rinse the inside of steamer compartment and drain valve thoroughly with clean water.
11. Inspect the probe assembly and clean it with a soft bristle brush or similar non-abrasive cleaning means.
12. Clean the door assembly.

- a) Remove the door gasket assembly. See Figure 6-1.
- b) Note the keyhole slots on the door and the retaining pins on the gasket assembly. Grasp the gasket assembly at the sides and lift up and towards you to remove the assembly.
- c) Clean all surfaces of the gasket assembly, as well as the inside of the door, by wiping with a damp cloth.
- d) Rotate the liner assembly 180° and replace the gasket assembly by sliding the retaining pins into the keyhole slots. Either long edge of the gasket assembly can be positioned at the top. Periodic rotating of the door assembly will help increase the door gasket life.



**Figure 6-1**

**Door Gasket Assembly  
(Model 22CGT3.1 Shown)**

13. Replace the cleaned KleanShield™, slide racks and fan guard. See Chapter 3.
14. Wipe the exterior with a damp cloth only.
15. NEVER HOSE DOWN THE STEAMER. Electrical components inside the unit will not function correctly if wet or damp and may cause a shock hazard.
16. After cleaning, leave the steamer door open until the next steamer operation. This prevents compartment odor buildup and helps increase gasket life.

## CHAPTER 7 OPERATING TESTS AND FINAL CHECKOUT PROCEDURES

---

- This procedure must be performed by a qualified Cleveland Range authorized service representative.
- Complete the Startup Procedure before starting the actual operating tests.
- Read and understand all steps of this procedure before starting.
- This procedure evaluates the function of the major operating controls of a SteamChef.

### A. Burner Ignition Test

**NOTICE:** Perform this test before the Startup Procedure below

#### 1. Lighting Instructions and Test of Direct Spark Ignition System

Step 1: If not already done:

- Leak test the water supply lines.
- Leak test the gas supply lines.
- Test the drain lines. Pour about a quart of water through the KleanShield™ drain and check that water flows out the drain and drainpipe.

Step 2: Turn the Main External Power Switch OFF.

Step 3: Open the cooking compartment door.

Step 4: Control Panel Settings:

- ON/OFF Switch: OFF.
- TIMED/MANUAL Mode: TIMED.

Step 5: Turn ON the power to the SteamChef at the Main External Power Switch.

- The 3-minute drain rinse cycle starts. Water flows from the drain and stops after 3 minutes.

Step 6: Turn ON the power to the SteamChef at the ON/OFF switch.

- a) The digital display turns on.
- b) The water reservoir begins to fill with water.
- c) The burner does NOT light.
- d) Close the cooking compartment door.
- e) After the cooking compartment door is closed and the water reservoir has filled to the operating level, the igniter spark initiates, and the automatic gas valve opens for 4 seconds.
  - If the SteamChef burner does NOT light within 4 seconds: the safety circuit in the igniter control de-energizes the system, closes the automatic gas valve, and locks out the ignition module and a continuous buzzer will sound. Go to f).
  - If the burner lights: The cooking compartment temperature rises to the operating temperature. Go to g).
- f) If the burner does NOT light, reset the system:
  - NOTE:** For new installations, or when air in gas lines is suspected, it may be necessary to bleed excess air from lines. Bleed air as close as possible to the inlet of the automatic gas valve.
  - i. Turn the ON/OFF SWITCH to OFF.
  - ii. Wait 5 minutes.
  - iii. Turn the ON/OFF SWITCH to ON to restart the SteamChef.
  - iv. Repeat up to 3 times (total of 4 attempts to light the burners).
    - If the burner lights in one to four attempts, go to g.
    - If the burner does NOT light after four attempts, go to Step 7.

- g) If the burner lights: Turn ON the cooking compartment by:
- EITHER switching to Manual Mode
  - OR Setting the Timer for 10 minutes
  - OR Turning the ON/OFF switch to ON

The cooking compartment temperature rises to operating temperature.

- h) IF the burner lights and the SteamChef heats properly within four attempts, end this test here.  
Skip step 7 and go to Section B OR If the SteamChef does NOT light or heat properly, go to Step 7.

Step 7: If the burner does NOT light or the SteamChef does not heat properly after the fourth attempt:

- Follow the Shutdown Instructions (below).
- Call a qualified Cleveland Range authorized service representative to adjust the burner controls.

## 2. Shutdown Instructions

Step 1: Turn OFF the electrical power to the SteamChef at the ON/OFF switch.

Step 2: Wait for the 3-minute Drain Rinse Cycle to run.

Step 3: Turn OFF the Main External Power Switch.

Step 4: Turn OFF the Main Manual Gas Valve.

## **B. Startup Procedure**

Step 1: Set the ON/OFF switch to the OFF position and open the SteamChef door. There should be no water in the SteamChef.

Step 2: Wait for the cooking compartment to cool from the Burner Ignition Test.

Step 3: See Figure 3-9. Remove the slide racks and the KleanShield™ and check that neither the KleanShield™ nor the reservoir drains are blocked. Replace the KleanShield™ and pan racks and check for proper installation of the KleanShield™, fan guard, air diverter, slide racks, and door gasket assembly.

Step 4: Be sure the Main External Power Switch is in the OFF position. See Figure 3-7.

Step 5: Verify installation of the proper size fuses or breakers. See the Rating Plate for electrical data.

Step 6: The front burner box cover is shipped loose. Wait until testing is done before installing it.

Step 7: Remove the control side panel.

Step 8: Check the internal wiring and make sure there are no loose or disconnected wires.

Step 9: Verify that the supply wiring is of adequate size and that the SteamChef is properly grounded.

Step 10: Correct any deficiencies.

## **C. Drain Rinse Inspection (Continued from Item 1, Startup Procedure)**

Step 1: Turn the ON/OFF switch to the OFF position.

Step 2: Turn ON the gas supply to the SteamChef (if not already on).

Step 3: Turn ON the water supply to the SteamChef (if not already on).

Step 4: Turn ON the electric power to the SteamChef at the Main External Power Switch.

a) The SteamChef immediately starts a 3-minute drain rinse cycle.

b) During the drain rinse cycle, the fill and drain valves are all the way open while the steam drain lines are flushed with fresh water.

Step 5: Stop the drain rinse cycle before it is complete by setting the ON/OFF switch to the ON position. This energizes the operating control circuits, stops the drain rinse cycle, and the fills the reservoir with water.

Step 6: Restart the drain rinse cycle by setting the ON/OFF switch to the OFF position. During the automatic drain rinse cycle, make the following checks.

a) The ON/OFF switch must be turned all the way to OFF to START the drain rinse cycle.

- b) Look at the gap between the SteamChef drain and the floor drain. A steady stream of water flows from the SteamChef drain. If no water flows, make sure the water supply is turned on.
- c) Check for plumbing leaks.
- d) After about 3 minutes, the cycle is complete. Check the gap at the floor drain. No more water flows from the drain.

#### D. Operating Tests (Continued from Drain Rinse Inspection)

Step 1: At the start of this test the cooking compartment door should be open and the controls should be set as follows:

- a) The Main External Power Switch is ON.
- b) The ON/OFF switch is OFF (The digital display turns off).

Step 2: Set the ON/OFF switch to the ON position. As the water reservoir fills, check the following functions:

- a) The digital display turns on.
- b) The fill valve opens and water begins to fill the compartment reservoir. Water appears in the bottom of the water reservoir.
- c) Close the compartment door to close the door interlock circuit. As the water level in the water reservoir rises:
  - Check that no water flows from the drain opening.
  - Check for plumbing leaks in the control area.

Step 3: When the water in the steam generator reaches the safe operating level (the level of the lower probe), the burner lights, the convection fan starts, and the SteamChef begins warming to the operating temperature.

Step 4: Open the door: the burner and convection fan turn OFF.

- a) Water continues to fill the generator and the water level in the reservoir continues to rise.
- b) The water in the reservoir stops rising when water reaches the upper probe.
  - If the water level continues to rise above the tip of the higher probe, see the **Operator's Troubleshooting Guide** in the Operator's Manual.
  - If the problem persists, have a qualified Cleveland Range authorized service representative check the probe circuit.

Step 5: Close the compartment door to close the door interlock circuit.

- a) The burner and the convection fan restart and the SteamChef heats to the operating temperature.
- b) When the operating temperature is reached, the convection fan and the burner turn OFF.
- c) If the SteamChef is left in Timed Mode or OFF, the burner, and convection fan cycle ON and OFF as the SteamChef maintains the operating temperature in the cooking compartment.

Step 6: Switch the steamer to MANUAL mode or the ON/OFF switch to ON.

- a) The cooking cycle starts.
- b) Check that:
  - 1) The burner lights.
  - 2) The convection fan turns on.
  - 3) Steam production starts.
  - 4) After a few minutes, the compartment reaches operating temperature.
  - 5) The convection fan remains on, and the burner will cycle to maintain operating temperature in the cooking compartment; the condenser water will cycle to maintain a drain temperature below 140°F. as long as the SteamChef remains on.
  - 6) In Manual Mode, the SteamChef continues to operate at the cooking mode for 60 minutes.
  - 7) No steam leaks around the door gasket.

**NOTE:** After 60 minutes of uninterrupted operation of both the Timer model SteamChefs in Manual Mode, and ON/OFF model SteamChefs turned ON, the SteamChef automatically starts the Energy Saver feature.

- The cooking compartment returns to standby mode. This saves energy and maximizes equipment life.
- To return the SteamChef to cooking mode: quickly open and close the compartment door, **OR** switch from Manual to Timed Mode and back to Manual Mode.

Step 7: Test the no-water/low water safety circuit:

- a) Leave the SteamChef in Manual Mode, or ON.
- b) Close the manual water supply valves to the SteamChef.
  - Condenser flow stops on Single Water Supply installations.
- c) When the water level drops below the low water safety level (lower probe):
  - The burner turns OFF.
  - The condenser flow stops on Separate Water Supply installations.
  - The convection fan stops.
  - The production of steam stops.
- d) Open the manual water supply valve to the SteamChef.
  - The SteamChef automatically refills the reservoir with water to the safety level (upper probe).
  - The burner lights, the convection fan starts, and condenser flow starts.
  - The production of steam starts.

Step 8: Switch to TIMED mode. The production of steam stops.

- a) The production of steam stops.
- b) The burner turns OFF.
- c) The condenser flow stops.
- d) The buzzer sounds for 3 seconds.
- e) The compartment returns to standby mode.

Step 9: Open the cooking compartment door to vent the steam and allow the compartment to cool.

Step 10: After 3 minutes, close the door and continue testing.

Step 11: Switch to TIMED mode.

Step 12: Set the Timer for 10 minutes.

Step 13: As soon as the dial is set, the steam generating cycle starts. This is the same sequence observed in Step 5, **EXCEPT:**

- The Timer controls the cycle.
- The time to produce steam is shorter because the SteamChef was preheated by Step 5.
- The Timer automatically returns the SteamChef to the standby mode after counting down to zero. See Step 8.

Step 14: After timed operation starts, check that:

- a) The burner lights and the convection fan turns on immediately.
- b) When the cooking compartment reaches cooking temperature, the timer begins counting down to zero and the condenser turns ON.
- c) A steady stream of water flows from the drainpipe.
- d) As the SteamChef generates steam, the reservoir water level falls and the solenoid clicks as it opens and closes the water fill valve to refill the reservoir



- e) Check for steam leaks around the door.
- f) When the timer counts down to zero, the burner turns OFF, the condenser flow and convection fan turn OFF, and the buzzer sounds for 3 seconds.
- g) After about 30 seconds, steam stops being produced.

**E. Shutdown of the SteamChef after Testing (Continued from Operating Tests) and Front Burner Cover Installation**

Step 1: Turn the SteamChef OFF by switching the ON/OFF switch to the OFF position.

- The digital display turns off.
- The automatic drain rinse cycle starts.
- Wait until the 3-minute drain rinse cycle is complete.

Step 2: When the drain rinse is complete, turn the SteamChef OFF at the Main External Power Switch.

Step 3: Replace the control side panel.

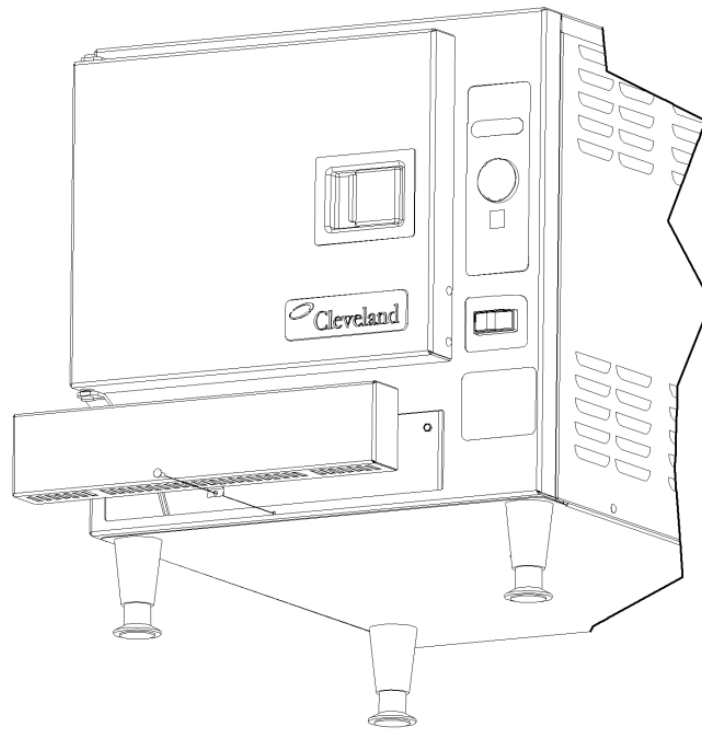
Step 4: When the SteamChef is cool, install the Front Burner Cover and secure it with the provided screws. See Figure 7-1.

Step 5: Restart and Shut Down the SteamChef.

- If the SteamChef starts and shuts down normally with the Front Burner Cover installed, it is ready for use. Go to Step 6.
- If there are any problems: STOP. Shut down the SteamChef and call Cleveland Range at 216-481-4900 or 1-800-338-2204.

Step 6: After completing the Operating Test Procedures and installing the Front Burner Cover, the SteamChef is ready for use.

Step 7: After the final shut down, leave the cooking compartment door open.



**Figure 7-1**  
**Front Burner Cover Installation**

# CHAPTER 8 PREVENTATIVE MAINTENANCE

## A. Maintenance

Maintenance on the steamer must be performed on a regular basis to keep it running properly and efficiently. By following the maintenance instructions in this chapter and cleaning the equipment regularly as outlined in Chapter 6, problems with the steamer will be kept to a minimum. The frequency of steamer maintenance may need to be increased, depending on equipment usage and water quality. If problems occur, refer to the Troubleshooting Guide. For more information on product and services, contact your sales representative.

### 1. Maintenance Records

Make a file for maintenance and repair records only. Keep a written record of daily, weekly, monthly, and yearly maintenance. These records will help protect warranty coverage, help schedule maintenance procedures, help keep the SteamChef cooking properly, and assist service personnel.

### 2. Daily Maintenance

#### a) Checking and Changing Water

When using the SteamChef Steamer frequently check the water, especially if cooking with perforated pans. Although most food drippings will be caught by the KleanShield™, the water may become dirty from spills falling over the edge of pans when loading, cooking, and emptying the steamer. Change the water (see below) when the water becomes cloudy or contaminated with food particles.

## NOTICE

**Change the water in the SteamChef steamer at least every day to maintain food quality and keep the steamer sanitary.**

It may be necessary to change the water several times a shift, especially if cooking strong-flavored foods or using perforated pans.

#### b) To Change the Water in the Reservoir:

- 1) Turn the ON/OFF switch to OFF to de-energize all controls and drain the steamer. Wait 3 minutes to allow drain cycle to complete.
- 2) Open the steamer door and allow steamer to cool.
- 3) Remove the KleanShield™. Remove any food particles and rinse the KleanShield™ with clean water.
- 4) Remove any spilled food from inside compartment and rinse any residue from the drain valve and the KleanShield™ drain.
- 5) Replace the KleanShield™. See Chapter 3.
- 6) Turn the ON/OFF switch to ON and the steamer will automatically begin filling with water to the normal operating level.
- 7) Close the door. The “SURE COOK” message will display, and the steamer will begin to automatically heat the water supply to the standby cooking temperature.
- 8) When the “SURE COOK” message turns OFF, the steamer is ready to begin cooking.

#### c) Cleaning the Steamer

Clean interior and exterior of the steamer according to the **Shutdown and Cleaning Instructions** in Chapter 6 at least once a day or at the end of each shift.

### 3. Yearly Maintenance

Clean the water line strainers at least once a year.

**NOTE:** When the steamer is first installed, check the strainer more frequently to find out how often the strainer must be cleaned.

- a) Turn OFF power to the steamer at the Main External Power Switch.
- b) Close the valves in the steamer water supply lines.
- c) Unscrew the hoses from the inlet fittings located on the rear of the steamer.

- d) Remove the filter washers from the outlet of the hoses and wash them with clean water.
- e) Check the filter washer for wear and replace it if necessary.
- f) Put the filter washers into each of the water inlets and reconnect the hoses to the back of the steamer.
- g) If treated water is used to supply water to the reservoir, make sure that it is connected to the left inlet at the rear of the steamer. See Figure 2-2.
- h) Open water supply valve(s) and check for water leaks.
- i) Turn power back on to the steamer at the Main External Power Switch.

**NOTE:** The appliance will perform the automatic 3-minute drain rinse cycle.

## B. Descaling Water Reservoir

**Only qualified Cleveland Range authorized technicians or trained onsite maintenance personnel may perform this procedure.**

1. Is Descaling Necessary?
  - a) Although a SteamChef should not normally require this procedure, the use of “hard” water or failure to follow the cleaning procedures in Chapter 6 may cause the accumulation of scale in the SteamChef.
  - b) Scale can deposit in the bottom of the SteamChef reservoir and/or in its drain. Descaling can help prevent a costly service call if scale buildup begins to impair the SteamChef’s operation.
  - c) Descaling is not normally required on a SteamChef. Frequency will depend on water quality, and the frequency of shutdown and cleaning of the water reservoir.
  - d) The frequency of descaling must be determined by the owner and performed by qualified Cleveland Range authorized technicians or trained onsite maintenance personnel.
2. If descaling is necessary, Cleveland Range recommends the use of DISSOLVE® Descaler Solution, Cleveland Range Part No. 106174. No other system of descaling should be used.

**NOTE:** Part No. 106174 is the part number for a case (6 1-gallon containers) of DISSOLVE® descaler.

3. Follow the instructions included with the DISSOLVE® Descaler Solution. Call Cleveland Range at 216-481-4900 or 1-800-338-2204 if there are any questions.

### **DESCALING PROCEDURE (For DISSOLVE® Descaler Solution P/N 106174):**

- This procedure takes about 1 hour 30 minutes to complete.
  - Repeat this procedure as needed for heavy scale buildup.
  - Regular cleaning of the steamer with vinegar per the instructions found in the **Shutdown and Cleaning Instructions** may help reduce need for descaling. See Chapter 6.
  - Sides, back, and top of steam compartments may be descaled with a vinegar solution and a soft brush. See Chapter 6.
1. Open the door to the cooking compartment.
  2. Set the ON/OFF switch to OFF.
    - The 3-minute drain cycle starts.
  3. Remove the Pan Racks and KleanShield™ from inside the steamer.
    - Heavily scaled pan racks and KleanShield™ may be descaled by soaking them in a solution of 1-part Dissolve® and 4-parts water, rinsing thoroughly with cold water, and washing them in a dishwasher.
  4. Remove any loose scale from the bottom of the steamer.
  5. When the drain cycle is done, turn the ON/OFF switch to ON to refill the unit.
  6. Do not start the timer.
  7. Leave the door open.

**NOTE:** DO NOT HEAT THE STEAMER DURING DESCALING.

8. While the reservoir is filling with water, pour 1 to 1 ½ quarts (about a third of a 1-gallon bottle) of DISSOLVE® descaler solution into the water reservoir.

- While adding DISSOLVE® descaler to the reservoir, pour it in slowly to avoid splashing the liquid or overflowing the reservoir.
9. After automatic fill ends, turn OFF the Main External Power Switch. See Figure 3-7.
  10. Leave the door open and let the DISSOLVE® work for 1 hour.
  11. At the end of 1 hour, set the ON/OFF switch to OFF.
  12. Turn the power ON at the Main External Power Switch.
  13. After the 3-minute drain cycle completes, turn the ON/OFF switch back ON. (**NOTE:** If the reservoir does not fill, dry off the water probe assembly).
  14. After filling stops, add 1/2 gallon of water to the reservoir. Do not overflow the reservoir.
  15. Turn the ON/OFF switch to OFF to start the drain cycle.
  16. After the reservoir drains, set the ON/OFF switch to ON to refill the reservoir.
  17. Close the cooking compartment door and set the timer for 20 minutes. The steamer heats to normal operating temperature.
  18. After 20 minutes turn the ON/OFF switch to OFF.
  19. The 3-minute drain cycle starts.
    - This is the final rinse of the reservoir.
  20. If the reservoir drains slowly even after being descaled, turn OFF the steamer and clean the drains with an NSF approved drain cleaner.
  21. Once the scale is removed and the drain flows freely, the steamer is ready for normal operation.

## **DANGER**

**The liquid solution in Cleveland Range Descaler Solution Part No. 106174 can be harmful if not handled properly. Follow these basic safety rules for handling and using this product. Instructions and warnings on container labels supersede all other warnings and instructions.**

Wear protective clothing when mixing or applying chemical cleaners.

Wear rubber gloves, and OSHA approved eye protection when descaling

Avoid breathing fumes.

If liquid contacts skin: wash with soap and water.

If chemical contacts eyes: flush with water and seek medical attention.

If chemical is swallowed or ingested: drink 1 or 2 glasses of water and seek medical attention.

**Failure to do so can cause DEATH or INJURY.**

## **CAUTION**

**Do not use any other product or method of descaling other than the DISSOLVE® Descaler method using part number 106174.**

**Failure to do so can cause DEATH or INJURY.**

## CHAPTER 9 TROUBLESHOOTING GUIDE

The Troubleshooting Guide is a list of symptoms of problems that may occur during routine operation.

- “Problem” (left column) lists common operating problems.
- “Possible Cause” (center column) lists causes of problems in the order they should be checked.
- “Remedy / Reference” (right column) lists fixes for problems from easiest to hardest.
- “Notes” in “Remedy / Reference column are at end of the Troubleshooting Guide.

**ATTEMPTING TO REPAIR OR CORRECT PROBLEMS REQUIRING A QUALIFIED CLEVELAND RANGE AUTHORIZED SERVICE REPRESENTATIVE VOIDS THE WARRANTY.**

PROBLEM	POSSIBLE CAUSE	REMEDY/REFERENCE
Digital display does not turn ON when ON/OFF switch is in the ON position.	Power turned OFF at Main External Power Switch.	Turn ON power at Main External Power Switch.
	ON/OFF switch not fully turned to the ON position.	Turn switch to the ON position.
	Inoperative controls or indicators.	See Note 1.
Power ON and appliance does not fill with water.	Water supply to appliance shut OFF.	Open water supply lines.
	Water line strainer and/or external filter system clogged.	Clean water supply strainer and/or filter system. See Yearly Maintenance.
	Water sensor is grounded by detergent film, or scale.	Clean water sensor assembly with vinegar solution. See Chapter 6.
	Inoperative controls or solenoids.	See Notes 1 and 5.
Control panel Power indicator is on, buzzer sounds continuously, reset indicator is lit.	High limit has been tripped.	Reset steamer. If problem repeats, see Note 1.
	Inoperative controls.	See Note 1.
Compartment bottom dirty with food drippings.	KleanShield™ not installed.	Install KleanShield™.
	Juices and/or food leaking from pans or spilling during loading and unloading.	Put a solid pan under perforated pans to catch drippings. Put less food in pans.
Digital display ON and steamer does not heat to cooking temperature or produce steam.	Door interlock switch not engaged.	Close door completely.
	Water supply to steamer closed.	Open water supply lines.
	Water line strainer and/or external filter system clogged.	Clean water supply strainer and/or filter system. See Yearly Maintenance.
	Appliance is in the Timed Mode and timer is not set.	Change to Manual Mode or set the timer.
	High limit switch has tripped.	Reset steamer. See Chapter 3. If condition repeats, see Note 1.
	Bottom of reservoir is heavily scaled.	See Note 1 or 9.
	Inoperative controls.	See Note 1.
Abnormal amount of steam coming from drain during draining of steamer.	ON/OFF switch is not fully OFF.	Turn switch to OFF to activate the drain cooling feature.
	Water line strainer and/or external filter system clogged.	Clean water supply strainer and filter system.
	Hot water instead of cold water connected to reservoir fill line	See Note 2 and 3.

	Inoperative controls.	See Note 1.
<p>Steam and/or water draining around the compartment door.</p> <p><b>See Warning under Note 7.</b></p>	The vent, the drain to the vent, and/or the KleanShield™ opening is clogged or covered.	Clear vent and collector openings. Clean the drain with NSF approved drain cleaner and flush drain thoroughly with fresh water. If condition persists see Note 1.
	Water Sensor dirty	Clean sensor thoroughly
	Door gasket or door parts worn.	See Note 1.
	Hot water instead of cold water connected to the condenser water line	See Note 2 and 3.
	External drain or vent not properly sized, installed, free air vented, and/or pitched down.	Make sure the drain is sized and installed properly. See Installation Manual. See Notes 2 and 3.
	Steamer not level.	See Note 2.
	Drain is blocked.	Clean drain with NSF approved drain cleaner. If problem persists, see Note 1.
	Inoperative controls	See Note 1.
<p>Steam coming out of the exhaust.</p>	A small amount of steam may issue from the exhaust whenever the unit is in the cooking mode.	This is normal operation of the steamer <b>NO</b> action is necessary.
	Condenser water supply is turned OFF	Turn ON Condenser water supply
	Water line strainer and/or external filter system clogged.	Clean water supply strainer and/or filter system.
	system clogged. Clean water supply strainer and/or filter system. Hot water instead of cold water connected to condenser supply line	See Note 2 and 3.
	Inoperative controls.	See Note 1.
<p>Abnormal amount of steam coming from drain or vent.</p>	Condenser water supply is turned OFF	Turn ON condenser water supply
	Hot water instead of cold water connected to the condenser water line	See Note 2 and 3.
	Condenser water line strainer clogged	Clean water supply strainer. See Yearly Maintenance.
	Inoperative controls	See Note 1
<p>Food takes too long to cook.</p> <p><b>To verify the steamers proper operation see Note 8.</b></p>	Pans too close to the bottom of cabinet.	Put pans in racks near top of cabinet.
	Compartment overloaded with too much food.	Put less food into pan. Use fewer pans.
	Suggested cooking times are usually listed for cooking at sea level.	Extend cooking times for altitudes above 2500 feet.
	Convection fan inoperative	See Note 1.
	Bottom of steamer is scaled.	See Note 9
	Voltage too low for unit.	See Note 4.
	Inoperative controls.	See Note 1.
Easy Timer display has noise/disruptions.	Power surge/not clean power.	Recommended power surge bar to resolve rare EMI/power disruptions.

## TROUBLESHOOTING NOTES

1. If the problem is inside the appliance, call a qualified Cleveland Range authorized service representative (Please have the model number and serial number ready when calling.) Cleveland Range will not pay for warranty repairs by unauthorized maintenance and repair centers.
2. Proper installation of the appliance is the responsibility of the Owner-User. Refer to the Warranty.
3. Repairs to external plumbing must be done by a Licensed Plumber.
4. Repairs to external wiring must be done by a Licensed Electrician.
5. If the automatic fill system fails for any reason, the steamer will stop heating when the water level drops below the minimum operating level. The steamer can be operated by manually filling the water reservoir with about a gallon of water approximately every half-hour, until service can be performed.
6. For more information on products and services, contact your nearest Authorized Sales Representative. Call the factory for a preventative maintenance program, descaling information, and water treatment systems.
7. Whenever opening door, especially when water or steam is leaking around the gasket, heed the warning below:

### **WARNING**

#### **Burn, Scald and Equipment Damage Hazard**

If the drain is blocked, hot water can fill the cooking compartment and spill out when the cooking compartment door is opened.

Signs of blocked drains include steam or water leaks around the cooking compartment door, and reduced cooking performance.

To help avoid injury:

- Stand on the hinge side and away from the appliance and slowly open the cooking compartment door.
- Inspect the drain(s) before each use and clean them if needed.

Failure to follow these precautions can cause BURNS, SCALDS, and EQUIPMENT DAMAGE.

8. Use the Egg Test to evaluate steamer performance.  
**NOTE:** this test is not valid for pressure steamers.
  - a) Turn on the steamer and set to MANUAL mode.
  - b) Preheat the steamer for ten minutes.
  - c) After the compartment is preheated, place a fresh egg on a perforated steam table pan in the middle of the cavity.
  - d) Close the door and set the timer as directed by the size chart below:

<b>Egg Size</b>	<b>Time</b>
Medium	12 minutes
Large	14 minutes
Extra Large	14 minutes

- e) Carefully remove the egg and place it in a container with cold water running over it.
  - f) Let cool under cold running water for 5 minutes.
  - g) After cooling, crack eggshell and peel.
  - h) A properly operating steamer produces a perfect hard-boiled egg.
9. Although, a SteamChef Steamer normally should not require descaling, the use of extremely “hard” water or failure to follow the cleaning procedures in the Shutdown and Cleaning Instructions may cause scale buildup. Have Cleveland Range authorized technicians or trained onsite maintenance personnel descale the steamer.

# Cleveland

Cleveland Range, LLC  
760 Beta Drive, Unit D  
Mayfield Village, Ohio 44143  
216.481.4900  
800.338.2204

---

Every new piece of Welbilt Foodservice equipment comes with KitchenCare® and you choose the level of service that meets your operational needs from one restaurant to multiple locations

**StarCare** – Warranty & lifetime service, certified OEM parts, global parts inventory, performance audited

**ExtraCare** – CareCode, 24/7 Support, online/mobile product information

**LifeCare** – Install & equipment orientation, planned maintenance, KitchenConnect™, MenuConnect®

**Talk with KitchenCare®** • 1-844-724-CARE • [www.mtwkitchencare.com](http://www.mtwkitchencare.com)



To learn how Welbilt Foodservice and its leading brands can equip you, visit our global web site at [www.welbilt.com](http://www.welbilt.com), then discover the regional or local resources available to you.