

PARTS MANUAL

PATENT PENDING

22CGT6

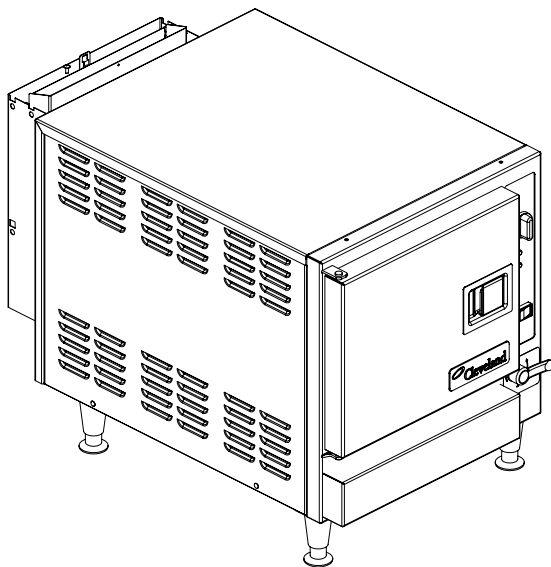

22CGT3

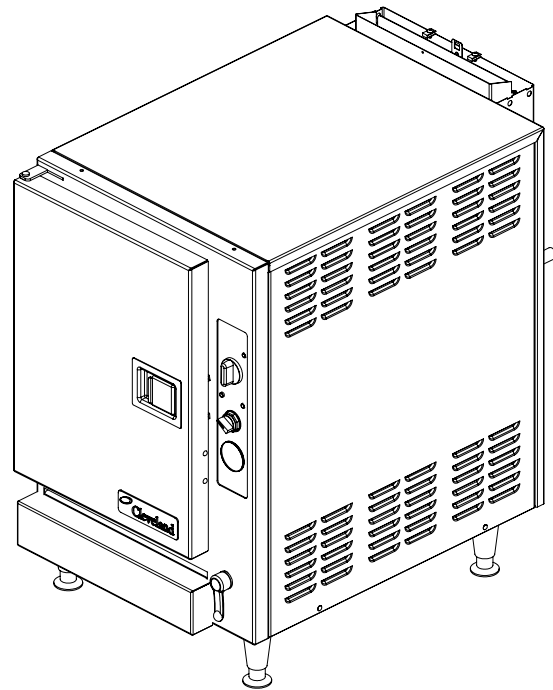

Series: SteamChef™ Models 22CGT3 and 22CGT6

1333 East 179th Street
Cleveland, Ohio 44110

Phone: (216) 481-4900
Fax: (216) 481 3782
www.clevelandrange.com

260BAZ REV. A JULY 2007

ITEM	QTY	PART NO.	DESCRIPTION	ITEM	QTY	PART NO.	DESCRIPTION	ITEM	QTY	PART NO.	DESCRIPTION	ITEM	QTY	PART NO.	DESCRIPTION	ITEM	QTY	PART NO.	DESCRIPTION	LET.	DESCRIPTION	DATE	BY
1	1	111329	BURNER TRAY ASSEMBLY, CHEF 3.6 GAS, H.L.	22	1	111351	SHAFT, KNOB/VALVE CHEF 3.6 GAS	43	2	102581	BUSHING, SNAP-IN FOR 1 1/2 DIA HOLE	64	1	300558	HI LIMIT, 130 DEG C, MANUAL RESET	85	4	108912	SCREW, HEX HD, 10-24x5/8, PLTD	A	PRODUCTION RELEASE	07-17-07	JJD
2	1	111331	BURNER BOX COVER, CHEF 3.6 GAS, H.L.	23	4	111002	FOOT, 4" ADJUSTABLE, FLANGED, STEAMCHEF	44	7	110496	NUT, SLIPON, 10-24, PNL .025	65	1	300558-1	SENSOR(PART OF ITEM 64)	86	1	112437	PAN, BASE, WELDMENT, STEAMCHEF, HL				
3	1	111338	FLUE ADAPTER ASSEMBLY, CHEF 3.6 GAS	24	1	111862	BAFFLE STRIP, LEFT	45	1	108331	BREAKER, CIRCUIT 1.0 A	66	1	111909	ASSEMBLY, RETAINER, INSULATED W/ PILOT CUTOUT, STEAMCHEF GAS	87	1	112243	BUSHING, SUPPORT, GEMINI				
4	1	111323	SHEETING, TOP/BACK, HL,STEAMCHEF 3(GAS)	25	1	111863	BAFFLE STRIP, RIGHT	46	1	108848	BRACKET, CIRCUIT BREAKER SHIELD STEAMCRAFT 3.1 & 5.1	67	1	111908	ASSEMBLY, RETAINER, INSULATED, STEAMCHEF GAS	88	1	112260	SHAFT COLLAR				
5	1	111518	BAFFLE, FLUE GAS, H.L./H.R.	26	1	111870	INSULATION, REAR BODY, CHEF 3 GAS, H.L.	47	8	101305	PIN, RACK SUPPORT, S/S, 316L	68	1	111919	ASSEMBLY, PIPING, DRAIN/POWER, ON/OFF, HL	89	1	02594	BUSHING, HEX, 3/8 x 1/4, BRASS				
6	1	111346	COVER PLATE, FAN ACCESS, CHEF 3.6	27	1	111272	SEAL, 1/4" ID X 3/4" OD X 1/4" THRU	48	1	1108842	BAFFLE, FAN, CHEF 3 GAS, HL & HR	69	1	110694	SPACER, CONTROL LEVER STEAMCHEF 3	90	1	02609	BUSHING, HEX, 1/4 x 1/8, BRASS				
7	1	111353	FLUE RISER ASSY, CHEF 3	28	18	14618	NUT, HEX, 1/4-20, STAINLESS STEEL	49	1	111890	GAS VALVE ASSY, NAT, CHEF 3/6 HL	70	1	102187	RING, RETAINING, .688 CRESCENT, J STEAMER	91	1	108068	THERMOCOUPLE, 1/8" DIA, 90°				
8	1	111343	FLUE GUARD, CHEF 3 GAS	29	14	101953	CLIP, INSULATION RETAINER, 1-1/2, .105 HOLE, GALV.	50	10	104080	COVER, ACCESS, CHEF	71	1	111389	BODY, WELDMENT, CHEF 3 GAS	92	1	104082	GASKET, STEAM INJECTOR, S/C				
9	1	111327	BURNER ACCESS PANEL/ DRIP TRAY, EMBOSSED	30	1	1113841	DOOR, OUTER ASSEMBLY, HL STEAMCHEF 3 W/LOGO	51	24	101231	SCREW, 10-24 X 0.500 SST, PHILLIPS TRUSS HEAD	72	4	111290	SCREW, SHOULDER, 1/4-20 W/FLAT, FAN GUARD AND MOTOR SUPPORT, 316L SST	93	1	3003312	PANEL ASSY, MECH. TIMER, CHEF, GAS-HL				
10	1	111384	ACCESS PANEL, CHEF 3.6 GAS, REAR	31	2	111324	DOOR, INNER ASSY, STEAMCHEF 6	52	4	101873	NUT, HEX 1/4-20 THIN LOCK, ZINC PLTD. STEEL	73	1	1118681	GUARD, FAN, STEAMCHEF	94	1	106526	CLAMP, HOSE, WORM DRIVE, 3/8 TO 5/8x5/16W, SST				
11	1	104035	HINGE, DOOR	32	1	110640	DOOR, OUTER ASSEMBLY, HL STEAMCHEF 6 W/LOGO	53	8	101655	WASHER, FLAT, #10, SST	74	1	1118682	GUARD, BACKPLATE, FAN, STEAMCHEF 3.1	95	2	101337	WASHER, LOCK, INTERNAL TOOTH, #8,SST				
12	2	104077	PIN, HINGE	33	2	14695	NUT, DOOR CATCH MOUNTING	54	5	14692	NUT, HEX, 10-24, ELASTIC LOCK, ZINC PLTD, FASTENER	75	3	104062	RING, EXT, RETAINING, SST	96	2	14598	NUT, HEX, 8-32, MS PLTD				
13	1	110683	MOTOR, BLOWER STEAMCHEF 3	34	1	104046	CATCH, DOOR	55	1	111880	INSULATION, FLUE ADAPTER, CHEF GAS, THIN	76	2	19170	SCREW, HEX HD, 1/4-20x5/8, SST	97	1	112360100	TUBE, NEOPRENE, 5/16"ID x 1"LG				
14	1	111735	RETAINER, INSULATION,FLUE ADAPTOR,GAS CHEF, H.L.	35	2	23149	WASHER, NYLON, TYPE 6/6	56	1	1118841	INSULATION, FLUE ADAPTER, CHEF GAS, THICK	77	10	23105	WASHER, LOCK, 1/4" KATLINK STYLE, SST	98	1	112442	RESTRICTOR, DRAIN, STEAMCHEF 3 & 6, GAS				
15	1	1040352	HINGE, OFFSET, HL, CHEF	36	2	14649	NUT, HEX, 1/2-13, ZINC PLTD	57	1	111884	INSULATION, FLUE ADAPTER, CHEF GAS, THICK	78	2	109232	SCREW, 1/4-20 X 1/2, HEX HD, SST	99	1	146771	NUT, ACORN, THRD LOCK, 1/4-20, SST				
16	1	110652	LEVER, CONTROL	37	1	104101	DOOR ASSY., INNER, CONV, STM.	58	14	108734	NUT, "U" TYPE (EXTRUDED) #10-24 UNC-2B THREAD	79	2	104719	SCREW, CARRIAGE, 1/4-20X1, SST	100	1	1113771	CLEAN SHIELD WELDMENT, CHEF 3.6, GAS, H.L.				
17	4	111798	NUT, RETAINER, 1/2-13NC, 2B	38	1	111886	DRAIN ASSEMBLY, STEAMCHEF, HL	59	1	3003231	ASSEMBLY, PROBE, DUAL LEVEL, HL	80	2	109482	NUT,LOCK, SELF,1/4-20 THIN HT. LT HEX	101	1	1119141	CONDENSER SPRAY ASSY, GAS CHEF 3 & 6				
18	1	111802	COMPONENT PANEL ASSEMBLY, STEAMCHEF 3 & 6 GAS	39	1	111730	ASSY, COVER, IGNITOR, CHEF GAS	60	1	2232001	CLAMP, HI-LIMIT BULB	81	1	19555	SPACER,1/4" I.D. X 1/2 O.D.	102	2	112483	BURNER ACCESS DRIP TRAY BRACKET				
19	1	111383	WATER VALVE ASSEMBLY, CHEF 3.6 GAS	40	1	02600	BUSHING, INSULATOR, 11/16 ID	61	2	111907	SCREW, SOC. HD., 10-32 X 3/4, SST	82	2	14665	NUT, HEX, 1/4-20 LOCK, SST (NYLON INSERT)	103	1	112319	LABEL, POWER CONTROL, STEAMCHEF 3.1/6.1 HL				
20	1	06241	FTG. HOSE BARB,3/4Hx1/2MPT, BR.	41	6	19148	SCREW, HEX WASHER HD, #10 x 1/2, TYPE AB, ZINC PLTD	62	2	110633	WASHER, LOCK, SPLIT RING, #10 SST	83	1	110421	DOOR, PILOT COVER	104	1	112345	ASSEMBLY, PLATE, MOTOR MOUNTING, STEAMCHEF 3.1/6.1, HL				
21	1	110713	SOCKET,1/4" DRIVE, 9/16" 12 POINT	42	13	23116	WASHER, FLAT, 281 ID x.625 OD x .065 THK, SST	63	1	108171	WHEEL, BLOWER BMW-334	84	4	14672	NUT, HEX, 10-32, ELASTIC LOCK, ZINC PLTD	105	1	195552	SPACER,1/4" I.D. X 1/2 O.D. X 0.688 LG.				

PARTS LISTED ABOVE ARE ALL COMMON BETWEEN THE STEAMCHEF 3 AND 6 EXCEPT FOR THE PARTS LISTED BELOW IN STEAMCHEF 6, GAS PARTS LIST

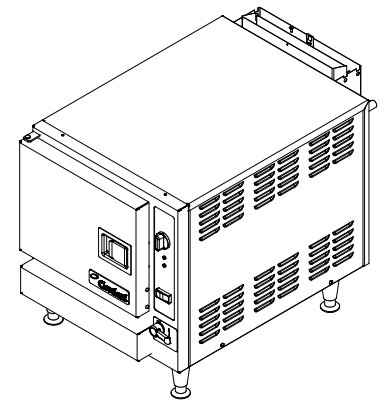
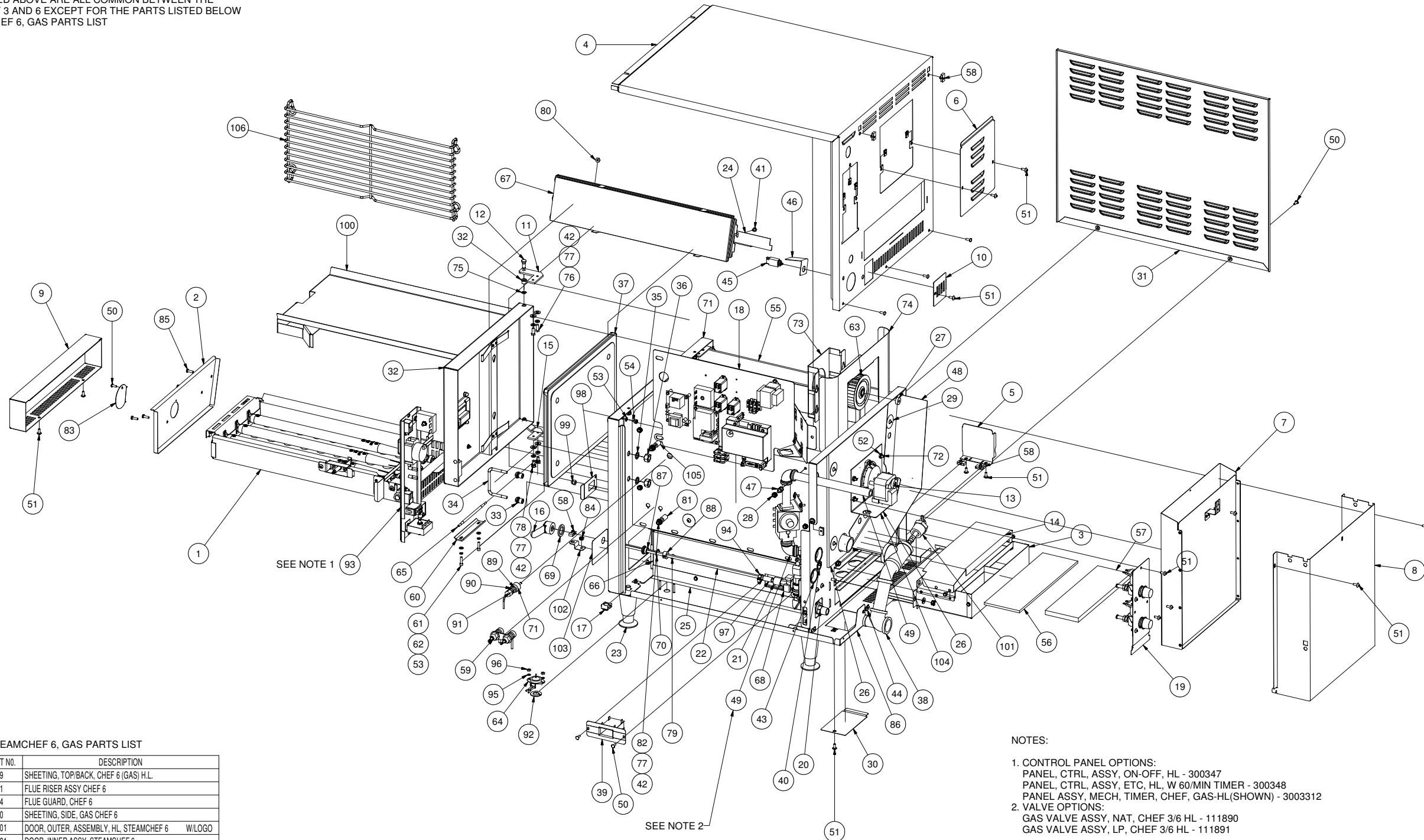

STEAMCHEF 3, GAS

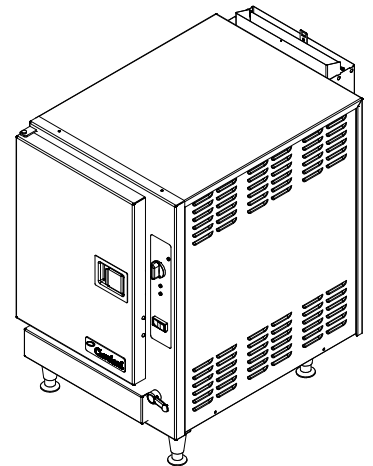

SETAMCHEF 6, GAS

STEAMCHEF 6, GAS PARTS LIST

ITEM	QTY	PART NO.	DESCRIPTION
4	1	111399	SHEETING, TOP/BACK, CHEF 6 (GAS) H.L.
7	1	111401	FLUE RISER ASSY CHEF 6
8	1	111404	FLUE GUARD, CHEF 6
31	2	111400	SHEETING, SIDE, GAS CHEF 6
32	1	1106401	DOOR, OUTER, ASSEMBLY, HL, STEAMCHEF 6 W/LOGO
37	1	1042021	DOOR, INNER ASSY, STEAMCHEF 6
71	1	111398	CAVITY, ASSEMBLY, WELDMENT, STEAMCHEF 6 GAS, H.L.
106	2	110832	PAN RACK STEAMCHEF 6

- NOTES:
- CONTROL PANEL OPTIONS:
 PANEL, CTRL, ASSY, ON-OFF, HL - 300347
 PANEL, CTRL, ASSY, ETC, HL, W 60/MIN TIMER - 300348
 PANEL ASSY, MECH, TIMER, CHEF, GAS-HL(SHOWN) - 3003312
 - VALVE OPTIONS:
 GAS VALVE ASSY, NAT, CHEF 3/6 HL - 111890
 GAS VALVE ASSY, LP, CHEF 3/6 HL - 111891

CLEVELAND RANGE, LLC				
1333 East 179th St., Cleveland, Ohio 44110-2574				
THIS DESIGN DESCRIBES A PROPRIETARY ITEM AND IS THE PROPERTY OF CLEVELAND RANGE. THIS DRAWING IS NOT TO BE COPIED OR USED WITHOUT THE APPROVAL OF CLEVELAND RANGE.				
TOLERANCES (UNLESS OTHERWISE NOTED)	DO NOT SCALE PRINTED DRAWING	DRAWN BY JJD	DATE 7/17/2007	
DECIMAL ± 0.030	TITLE INSTRUCTION, ASSEMBLY, STEAMCHEF, GAS			
ANGULAR ± 1°	SIZE D	DRAWING NO. 260BAZ	SHEET 1 OF 1	REV A

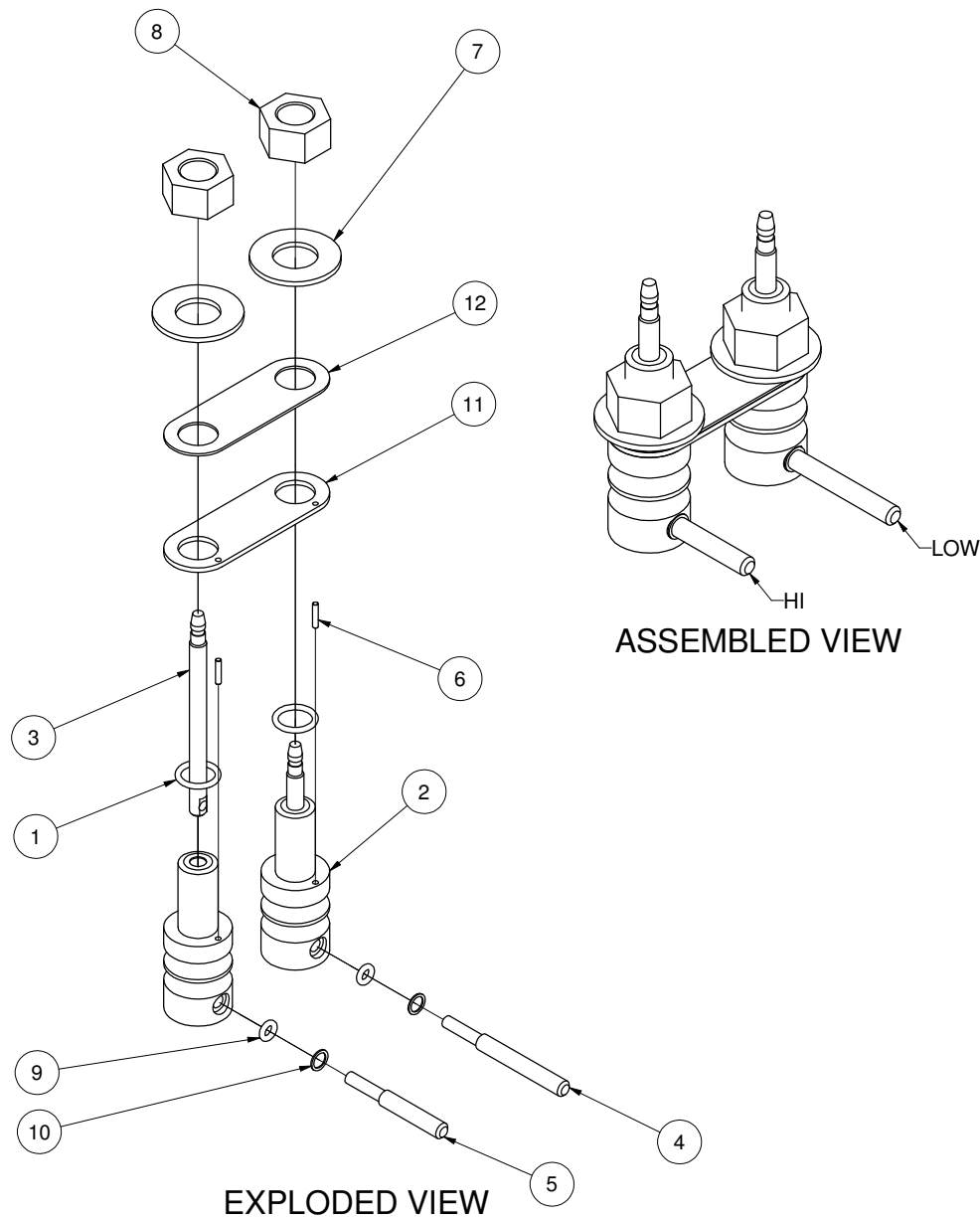

LET.	DESCRIPTION	DATE	BY
B	DRAWING RELEASE, PER EO# C-8700R1	9-13-04	VDS
C	UPDATE PRODUCT STREAM DATA "PER ECR-07-177"	04-25-07	LPH
D	UPDATE PRODUCT STREAM DATA "PER ECR-07-181"	04-25-07	LPH

12	1	111317	GASKET, LOCK PLATE, PROBE
11	1	111308	PLATE, LOCK/POSITION, PROBE
10	2	111321	WASHER, FLAT, 0.143 ID X 0.267 OD, 316 SS
9	2	111322	O-RING, 0.125 I.D. X 0.0250 O.D., SILICON
8	2	111313	NUT, HEX, 7/16-20 NYLON
7	2	111452	WASHER, FLAT, ID 0.500, OD 1.003, THK. 0.062, TEFLON
6	2	111453	PIN, DOWEL, 1/16 X 5/16, 304 SST
5	1	111310	PROBE EXTENSION, (HI)
4	1	111311	PROBE EXTENSION, (LOW)
3	2	111312	ROD, PROBE CONNECTION
2	2	111309	BUSHING, PROBE
1	2	109964	SEAL, O-RING, 0.375 I.D. X 0.500 O.D.

ITEM	QTY	PART NO.	DESCRIPTION
CLEVELAND RANGE, LLC 1333 East 179th St., Cleveland, Ohio 44110-2574 <small>THIS DESIGN DESCRIBES A PROPRIETARY ITEM AND IS THE PROPERTY OF CLEVELAND RANGE. THIS DRAWING IS NOT TO BE COPIED OR USED WITHOUT THE APPROVAL OF CLEVELAND RANGE.</small>			
<small>TOLERANCES (UNLESS OTHERWISE NOTED)</small> DECIMAL ± 0.030		<small>DO NOT SCALE PRINTED DRAWING</small>	<small>DRAWN BY</small> VDS <small>DATE</small> 9/8/2004
<small>ANGULAR</small> $\pm 1^\circ$		<small>TITLE</small> ASSEMBLY, PROBE, DUAL LEVEL, HL	
		<small>SIZE</small> B <small>DRAWING NO.</small> 3003231	<small>SHEET 1 OF 1</small> <small>REV</small> D

LET.	DESCRIPTION	DATE	BY
A	PRODUCTION RELEASE "PER ECR-07-209"	05-04-07	LPH
B	PICTORIAL UPDATE ITEM 1 "PER ECR-07-257"	06-08-07	LPH

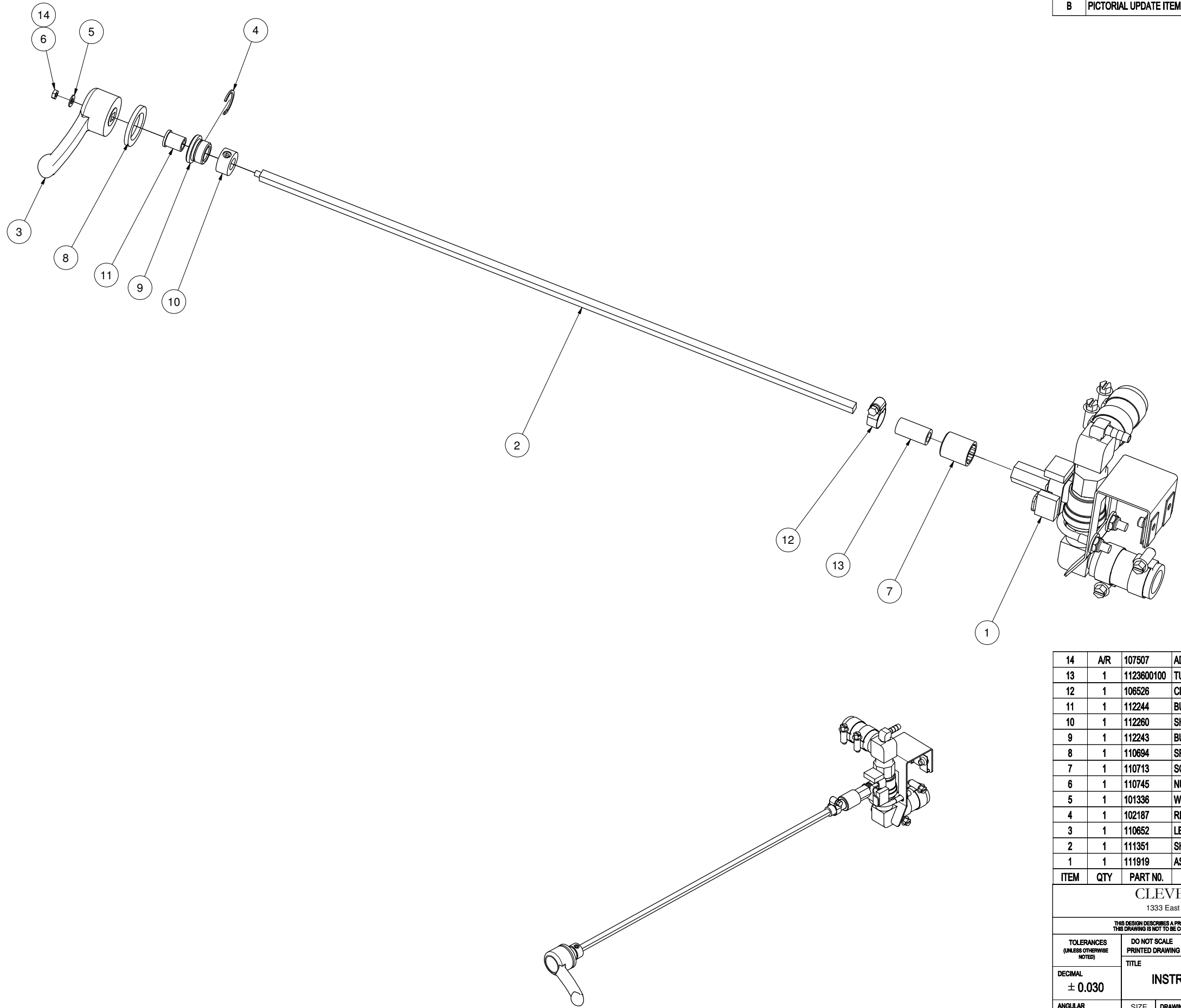

14	A/R	107507	ADHESIVE, LOCTITE BLUE, THREAD LOCKER 242
13	1	1123600100	TUBE, NEOPRENE, 5/16"ID x 1"LG
12	1	106526	CLAMP, HOSE, WORM DRIVE, 3/8 TO 5/8x5/16W, SST
11	1	112244	BUSHING, INSERT
10	1	112260	SHAFT COLLAR
9	1	112243	BUSHING, SUPPORT, GEMINI
8	1	110694	SPACER, CONTROL LEVER STEAMCHEF 3
7	1	110713	SOCKET, 1/4" DRIVE, 9/16" 12 POINT
6	1	110745	NUT, HEX, 8-32 SMALL PATTERN, 1/4", SST
5	1	101336	WASHER, FLAT, #8, SST
4	1	102187	RING, RETAINING, .688 CRESCENT, J STEAMER
3	1	110652	LEVER, CONTROL
2	1	111351	SHAFT, KNOB/VALVE CHEF 3,6 GAS
1	1	111919	ASSEMBLY, PIPING, DRAIN/POWER, ON/OFF, HL
ITEM	QTY	PART NO.	DESCRIPTION

CLEVELAND RANGE, LLC 1333 East 179th St., Cleveland, Ohio 44110-2574			
THIS DESIGN DESCRIBES A PROPRIETARY ITEM AND IS THE PROPERTY OF CLEVELAND RANGE. THIS DRAWING IS NOT TO BE COPIED OR USED WITHOUT THE APPROVAL OF CLEVELAND RANGE.			
TOLERANCES (UNLESS OTHERWISE NOTED)	DO NOT SCALE PRINTED DRAWING	DRAWN BY LPH	DATE 4/25/2006
TITLE INSTRUCTION, PIPING, DRAIN/POWER ON-OFF			
DECIMAL ± 0.030	SIZE C	DRAWING NO. 1119191	SHEET 1 OF 1 B

NOTE:
 1) USE ONLY TEFLON TAPE, DO NOT SUBSTITUTE ANOTHER MATERIAL.

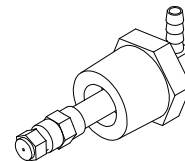
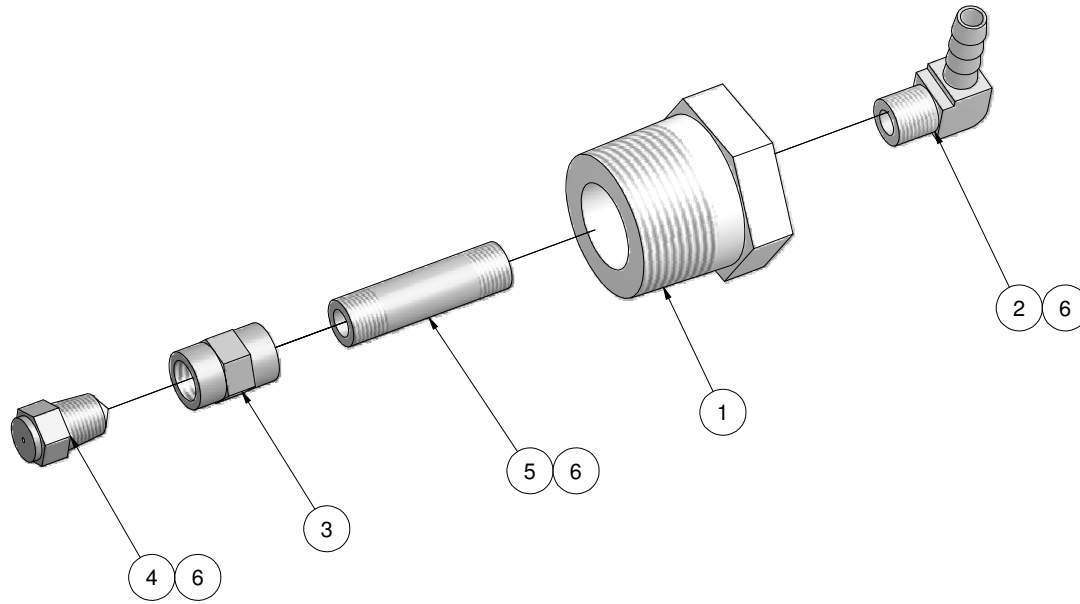

LET.	DESCRIPTION	DATE	BY
A	PRODUCTION RELEASE PER ECR-07-172	4-27-07	IG

ITEM	QTY	PART NO.	DESCRIPTION
6	A/R	00946	SEALANT, TAPE, 1/2" TEFLON
5	1	14297	NIPPLE, 1/8 x 1-1/2, BRASS
4	1	14556	SPRAY, NOZZLE, MALE 1/8" NPT
3	1	104838	COUPLING, 1/8" NPT - BRASS
2	1	105787	FITTING, HOSE BARB, 90°, 1/4 H X 1/8 NPT(M)
1	1	06230	FITTING, COMPARTMENT DRAIN

CLEVELAND RANGE, LLC
 1333 East 179th St., Cleveland, Ohio 44110-2574

THIS DESIGN DESCRIBES A PROPRIETARY ITEM AND IS THE PROPERTY OF CLEVELAND RANGE.
 THIS DRAWING IS NOT TO BE COPIED OR USED WITHOUT THE APPROVAL OF CLEVELAND RANGE.

TOLERANCES (UNLESS OTHERWISE NOTED)	DO NOT SCALE PRINTED DRAWING	DRAWN BY LPH	DATE 6/14/2006
DECIMAL ± 0.030	TITLE CONDENSER SPRAY ASSY, GAS CHEF 3 & 6		
ANGULAR ± 1°	SIZE B	DRAWING NO. 1119141	SHEET 1 OF 1 REV A

LET.	DESCRIPTION	DATE	BY
A	PRODUCTION RELEASE PER EO#C-6729	10-5-04	IG
B	ADDED ITEMS 17-19 PER EO# C-7017	03-15-06	LPH
C	PICTORIAL UPDATE OF ITEM 1, RELOCATED ITEM 11 PER	03-26-07	LPH
-	PER EO# 07-096	-	-

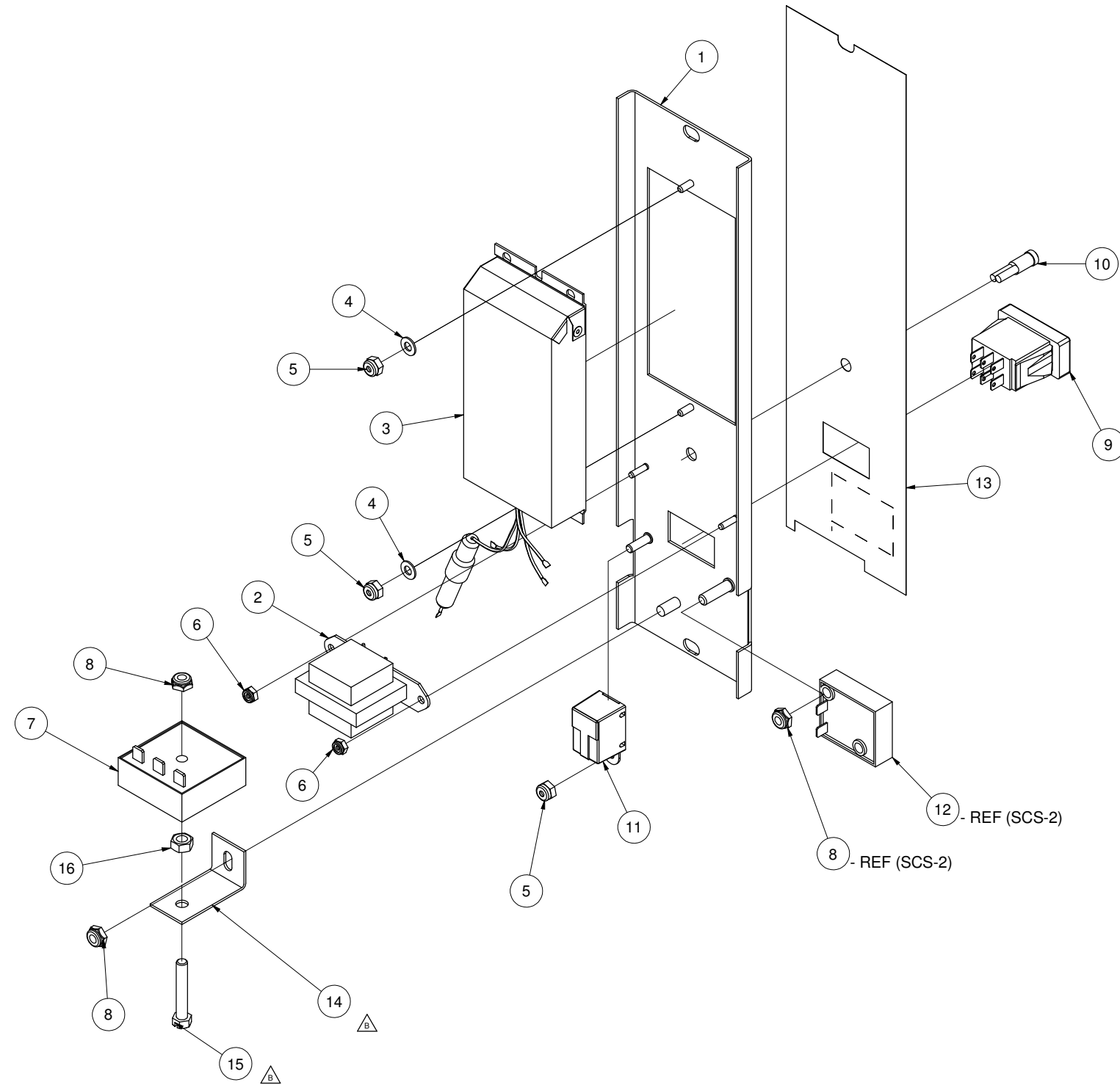

NOT SHOWN {

19	1	20351	TERMINAL, SLIP-ON, FULL INSUL, .032X .250 TAB
18	1	300346	HARNESS, WIRE, ELEC CONTROL PANEL
17	1	109153	LABEL, SLIP-IN MODEL NO./SERIAL NO.
16	1	14617	NUT, HEX 1/4-20 STEEL OXIDE FINISH
15	1	19175	SCREW, HEX HD, NON-SLTD
14	1	105955	BRACKET, DUAL TIMER MOUNTING
13	1	1106681	LABEL, NCC TIMER, STEAMCHEF
12	-	108880	SWITCH, DOOR STEAM CUTOFF
11	1	41350	BUZZER, ASSY, CONTINUOUS DUTY, 120VAC, 50-60HZ
10	1	12159	LIGHT, INDICATOR, NEON, RED, 7" MIN LEAD LENGTH
9	1	104224	SWITCH, ROCKER DPDT, MATTE
8	2	101873	NUT, HEX 1/4-20 THIN LOCK, ZINC PLTD. STEEL
7	1	300150	TIMER, SOLID STATE, 60 MINUTE FIXED DELAY
6	2	104223	NUT, HEX 6-32 ELASTIC LOCK
5	3	14692	NUT, HEX, 10-24, ELASTIC LOCK, ZINC PLTD, FASTENER
4	2	101655	WASHER, FLAT, #10, SST
3	1	104389	TIMER ASSEMBLY NCC
2	1	104390	TRANSFORMER ASSEMBLY
1	1	1106641	PANEL, CONTROL, WELDMENT, ETC TIMER, STEAMCHEF, HL

ITEM	QTY	PART NO.	DESCRIPTION
------	-----	----------	-------------

CLEVELAND RANGE, LLC
1333 East 179th St., Cleveland, Ohio 44110-2574

THIS DESIGN DESCRIBES A PROPRIETARY ITEM AND IS THE PROPERTY OF CLEVELAND RANGE. THIS DRAWING IS NOT TO BE COPIED OR USED WITHOUT THE APPROVAL OF CLEVELAND RANGE.

TOLERANCES (UNLESS OTHERWISE NOTED)	DO NOT SCALE PRINTED DRAWING	DRAWN BY IGenzel	DATE 10/5/2004
DECIMAL ± 0.030	TITLE PANEL, CTRL, ASSY, ETC, HL, W/60 MIN MANUAL TIMER, CHEF		
ANGULAR ± 1°	SIZE C	DRAWING NO. 300348	SHEET 1 OF 1 REV C

LET.	DESCRIPTION	DATE	BY
A	PRODUCTION RELEASE PER EO#C-6729	10-6-04	IG
B	PICTORIAL UPDATE , SWITCH ROTATED PER EO# C-7017	03-14-06	LPH
C	PICTORIAL UPDATE ITEM 1 PER ECR# 07-096	03-26-07	LPH

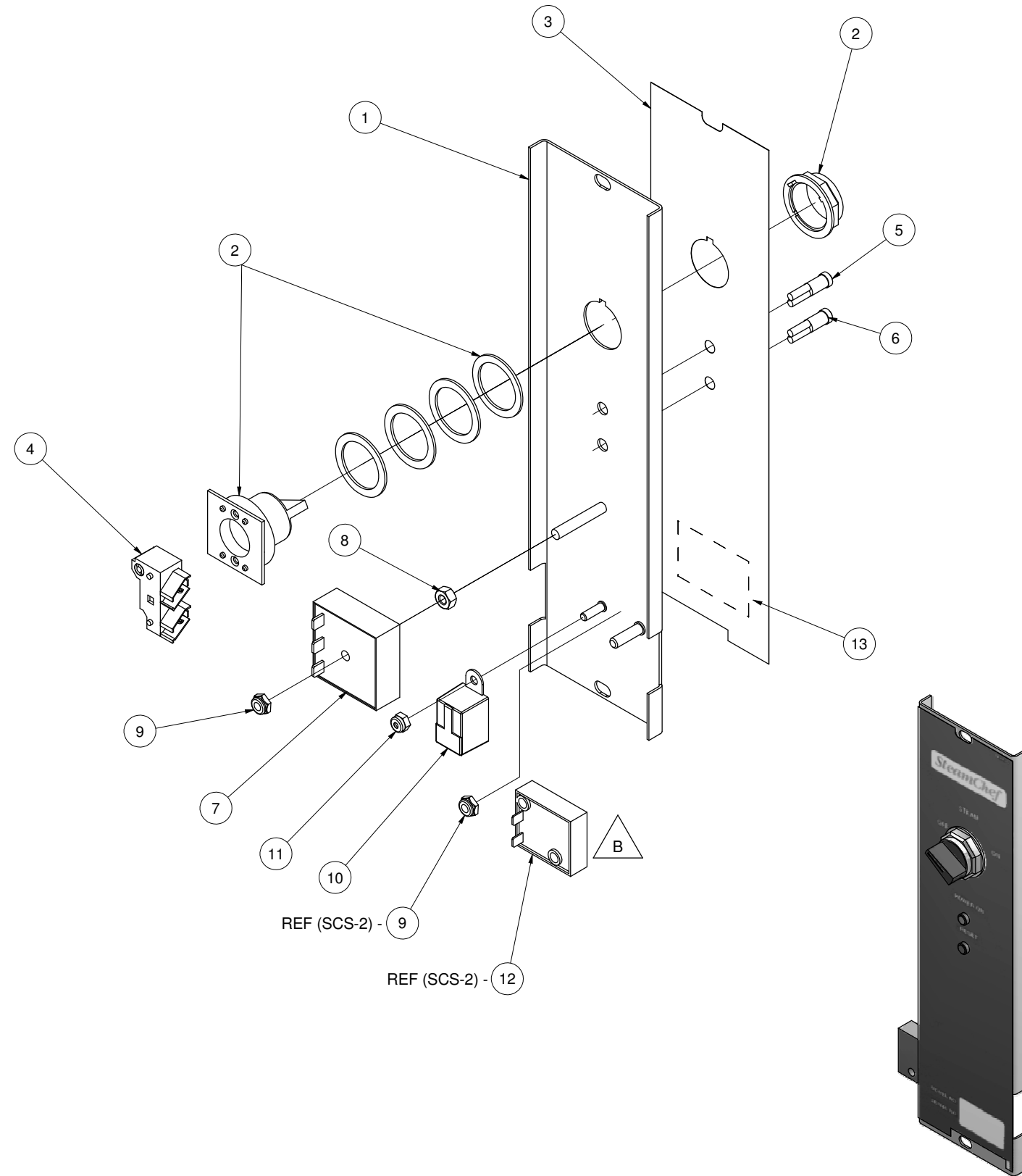

NOT SHOWN
NOT SHOWN

REF

15	4	20351	TERMINAL SLIPON FULL-INSUL
14	1	300345	HARNESS, WIRE CTRL PANEL, ON-OFF
13	1	109153	LABEL, SLIP-IN, MODEL NO/SERIAL NO.
12	-	108880	SWITCH, DOOR STEAM CUTOFF
11	1	14692	NUT, HEX, 10-24, ELASTIC LOCK, ZINC PLTD, FASTENER
10	1	41350	BUZZER, ASSY, CONTINUOUS DUTY, 120VAC, 50-60HZ
9	1	101873	NUT, HEX 1/4-20 THIN LOCK, ZINC PLTD, STEEL
8	1	14618	NUT, HEX, 1/4-20, STAINLESS STEEL
7	1	300150	TIMER, SOLID STATE, 60 MINUTE FIXED DELAY
6	1	12159	LIGHT, INDICATOR, NEON, RED, 7" MIN LEAD LENGTH
5	1	109494	LIGHT, GREEN INDICATOR, NEON, 120V
4	1	102533	BLOCK, CONTACT
3	1	110669	LABEL, CTRL, ON/OFF, STEAMCHEF
2	1	102534	SWITCH, SELECTOR
1	1	110666	PANEL, CONTROL, WELDMENT, ON/OFF, STEAMCHEF, HL

ITEM	QTY	PART NO.	DESCRIPTION
CLEVELAND RANGE, LLC			
1333 East 179th St., Cleveland, Ohio 44110-2574			
<small>THIS DESIGN DESCRIBES A PROPRIETARY ITEM AND IS THE PROPERTY OF CLEVELAND RANGE. THIS DRAWING IS NOT TO BE COPIED OR USED WITHOUT THE APPROVAL OF CLEVELAND RANGE.</small>			
TOLERANCES (UNLESS OTHERWISE NOTED)	DO NOT SCALE PRINTED DRAWING	DRAWN BY IGenzel	DATE 10/6/2004
DECIMAL ± 0.030	TITLE PANEL, CTRL, ASSY, ON-OFF, HL, CHEF		
ANGULAR ± 1°	SIZE C	DRAWING NO. 300347	SHEET 1 OF 1 REV C

NOTE:

1. APPLY ITEM 11 TO ITEMS 3, 5 & 10 IF REQUIRED.

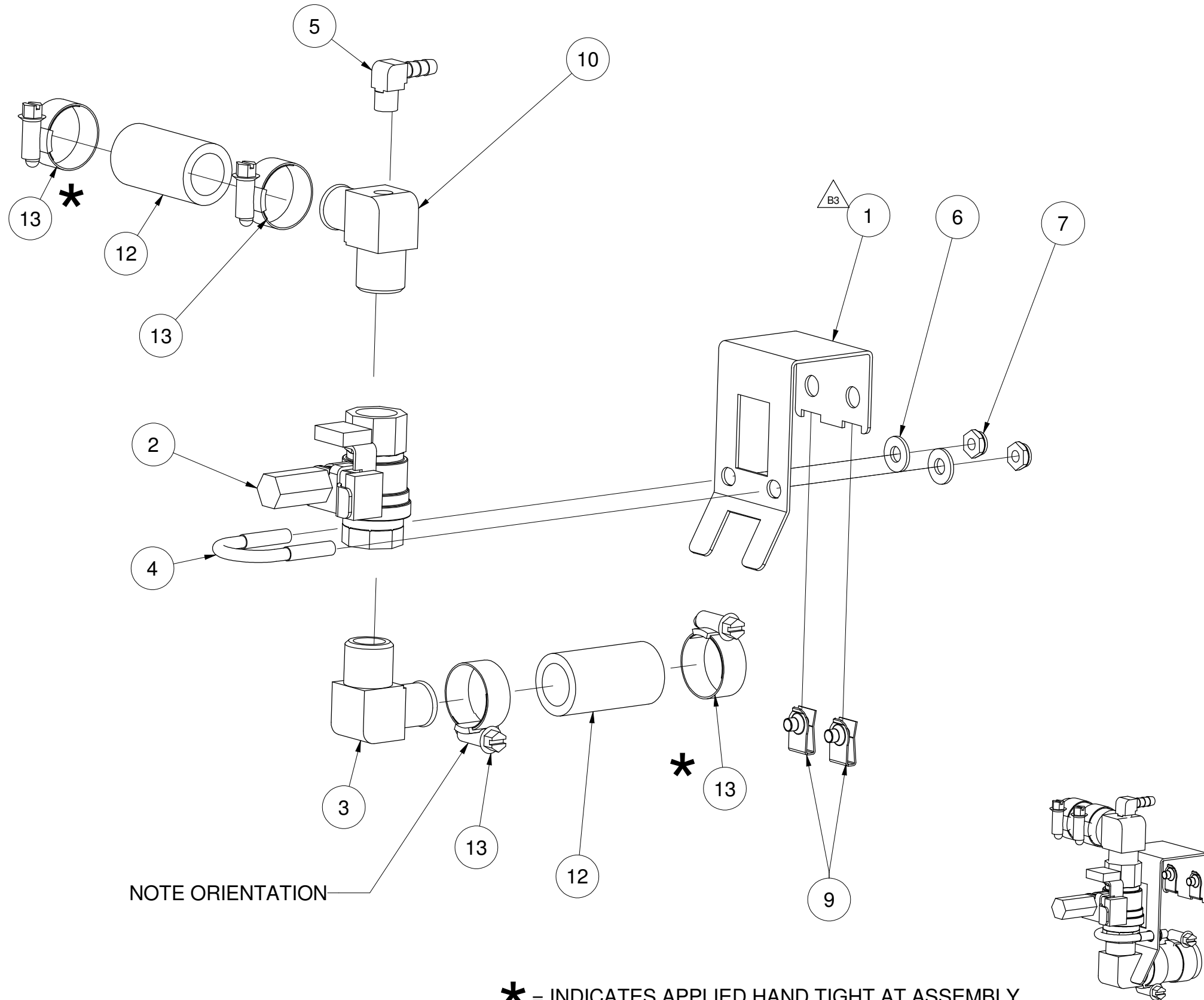

* = INDICATES APPLIED HAND TIGHT AT ASSEMBLY.

LET.	DESCRIPTION	DATE	BY
A	PRODUCTION RELEASE "PER ECR 07-172"	05-03-07	LPH
B	ITEM 6 WAS P/N 23105, 2) ITEM 7 WAS P/N 14618, 3) PICT.	05-09-07	LPH
-	UPDATE ITEM 1, 4) ADD ITEMS 12 & 13 "PER ECR-07-209"	-	-
C	1) DELETED ITEM 8, 2) ITEM 9 WAS P/N 110581	06-08-07	LPH
-	"PER ECR-07-257"	-	-

△B4	13	4	03207	HOSE, CLAMP, LINED, WORM DRIVE, MAX OD 1.125
△B4	12	2	1060930200	HOSE, SILICONE, 3/4"ID X 2.000" LG.
	11	A/R	00934	SEALANT, PIPE DOPE
	10	1	1113541	FTG, BARB, 3/4H x 1/2 MPT x 1/8" FPT, 90 DEG, BRASS
△C2	9	2	108734	NUT, "U" TYPE (EXTRUDED) #10-24 UNC-2B THREAD
△C1	8			
△B2	7	2	101873	NUT, HEX 1/4-20 THIN LOCK, ZINC PLTD. STEEL
△B1	6	2	23116	WASHER, FLAT, .281 ID x .625 OD x .065 THK, SST
	5	1	105787	FITTING, HOSE BARB, 90°, 1/4 H X 1/8 NPT(M)
	4	1	110709	"U" BOLT, 1/2" PIPE, 1-4-20 THREAD, ZINC PLATED STL.
	3	1	111354	FTG, BARB, 3/4H x 1/2 MPT, 90 DEG, BRASS
	2	1	110613	BALL VALVE ASSEMBLY, DOUBLE SWITCH
	1	1	112406	BRACKET, VALVE MOUNT, GAS CHEF
ITEM	QTY	PART NO.	DESCRIPTION	

CLEVELAND RANGE, LLC

1333 East 179th St., Cleveland, Ohio 44110-2574

THIS DESIGN DESCRIBES A PROPRIETARY ITEM AND IS THE PROPERTY OF CLEVELAND RANGE. THIS DRAWING IS NOT TO BE COPIED OR USED WITHOUT THE APPROVAL OF CLEVELAND RANGE.

TOLERANCES (UNLESS OTHERWISE NOTED)	DO NOT SCALE PRINTED DRAWING	DRAWN BY LPH	DATE 5/3/2007
DECIMAL ± 0.030	TITLE ASSEMBLY, PIPING, DRAIN/POWER, ON/OFF, HL		
ANGULAR ± 1°	SIZE B	DRAWING NO. 111919	SHEET 1 OF 1 REV C

NOTE:
 1.) INSTALL ITEM 7 AFTER ASSEMBLY P/N 111891 IS MOUNTED TO ELECTRICAL COMPONENT PANEL P/N 111802.

LET.	DESCRIPTION	DATE	BY
A	PRODUCTION RELEASE PER ECR-07-172	4-25-07	IG

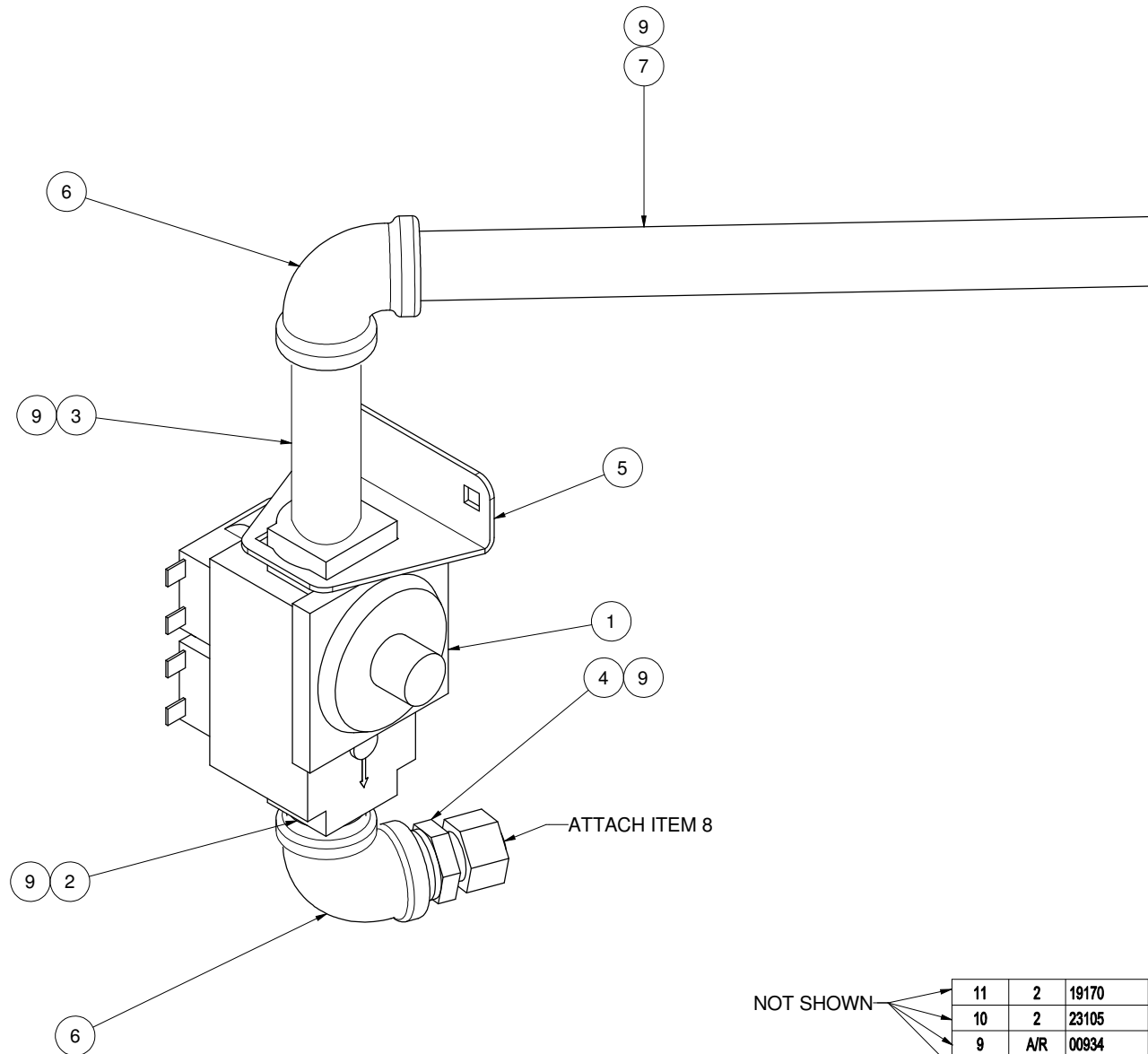
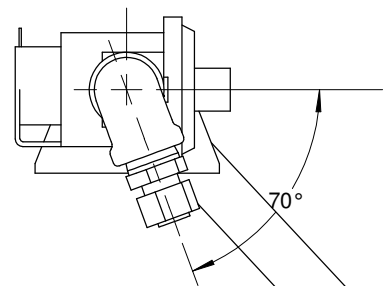
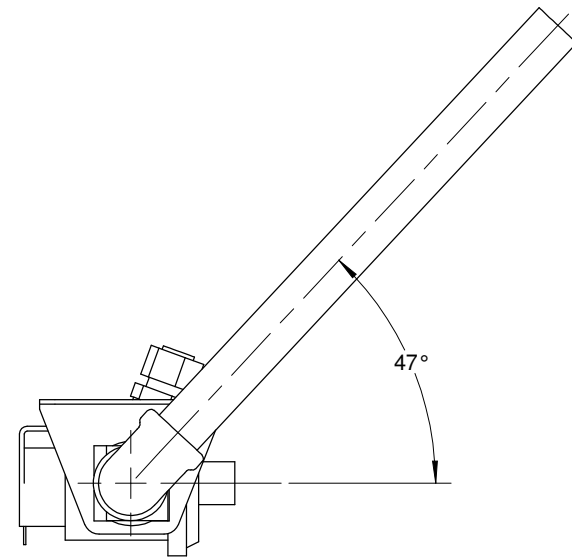

NOT SHOWN

11	2	19170	SCREW, 1/4-20 X 5/8, HEX HD. SST
10	2	23105	WASHER, LOCK, 1/4, SST
9	A/R	00934	THREAD SEALANT
8	1	111101	GAS LINE, FLEXIBLE, .5 X 13.000 LONG, SST
7	1	14441	NIPPLE, .50 NPT X 9.50 SCH. 40, BLK, TBE
6	2	05249	ELBOW, 90 DEG., 1/2" BLK
5	1	111799	BRACKET, GAS VALVE MOUNT
4	1	06204	FTG., COMP. 1/2T x 1/2MPT PARKER HANIFIN 68CA-8-8
3	1	14333	NIPPLE .50 NPT X 3.50 SCH 40, BLK, IRN, TBE
2	1	14323	NIPPLE, 1/2 x CLOSE, BLACK
1	1	1118141	VALVE, GAS, LP, COMBINATION, 1/2" NPT, 24VAC
ITEM	QTY	PART NO.	DESCRIPTION

CLEVELAND RANGE, LLC
 1333 East 179th St., Cleveland, Ohio 44110-2574

THIS DESIGN DESCRIBES A PROPRIETARY ITEM AND IS THE PROPERTY OF CLEVELAND RANGE. THIS DRAWING IS NOT TO BE COPIED OR USED WITHOUT THE APPROVAL OF CLEVELAND RANGE.

TOLERANCES (UNLESS OTHERWISE NOTED)	DO NOT SCALE PRINTED DRAWING	DRAWN BY LPH	DATE 3/1/2006
DECIMAL ± 0.030	TITLE GAS VALVE ASSY, LP, CHEF 3/6 HL		
ANGULAR ± 1°	SIZE C	DRAWING NO. 111891	SHEET 1 OF 1 REV A

NOTE:
 1.) INSTALL ITEM 5 AFTER ASSEMBLY P/N 111890 IS MOUNTED TO ELECTRICAL COMPONENT PANEL P/N 111802.

LET.	DESCRIPTION	DATE	BY
A	PRODUCTION RELEASE PER ECR-07-172	4-25-07	IG

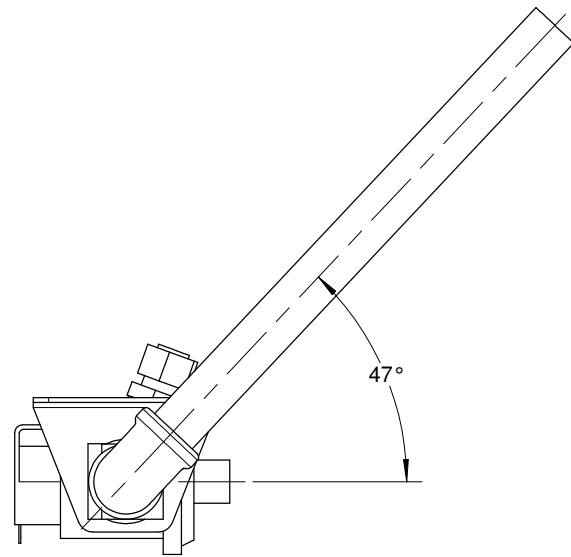

TOP VIEW

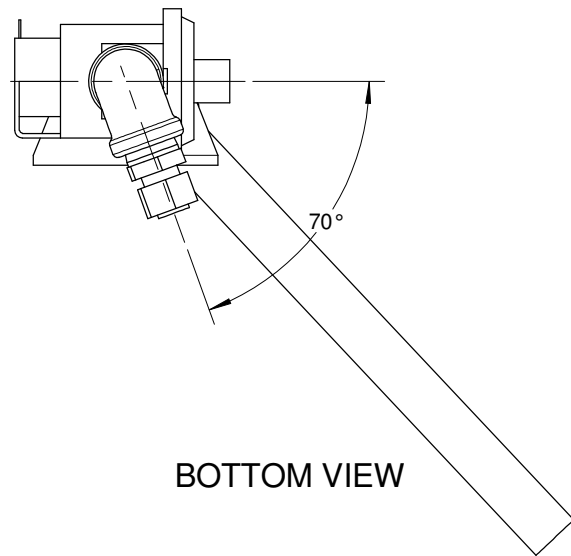

BOTTOM VIEW

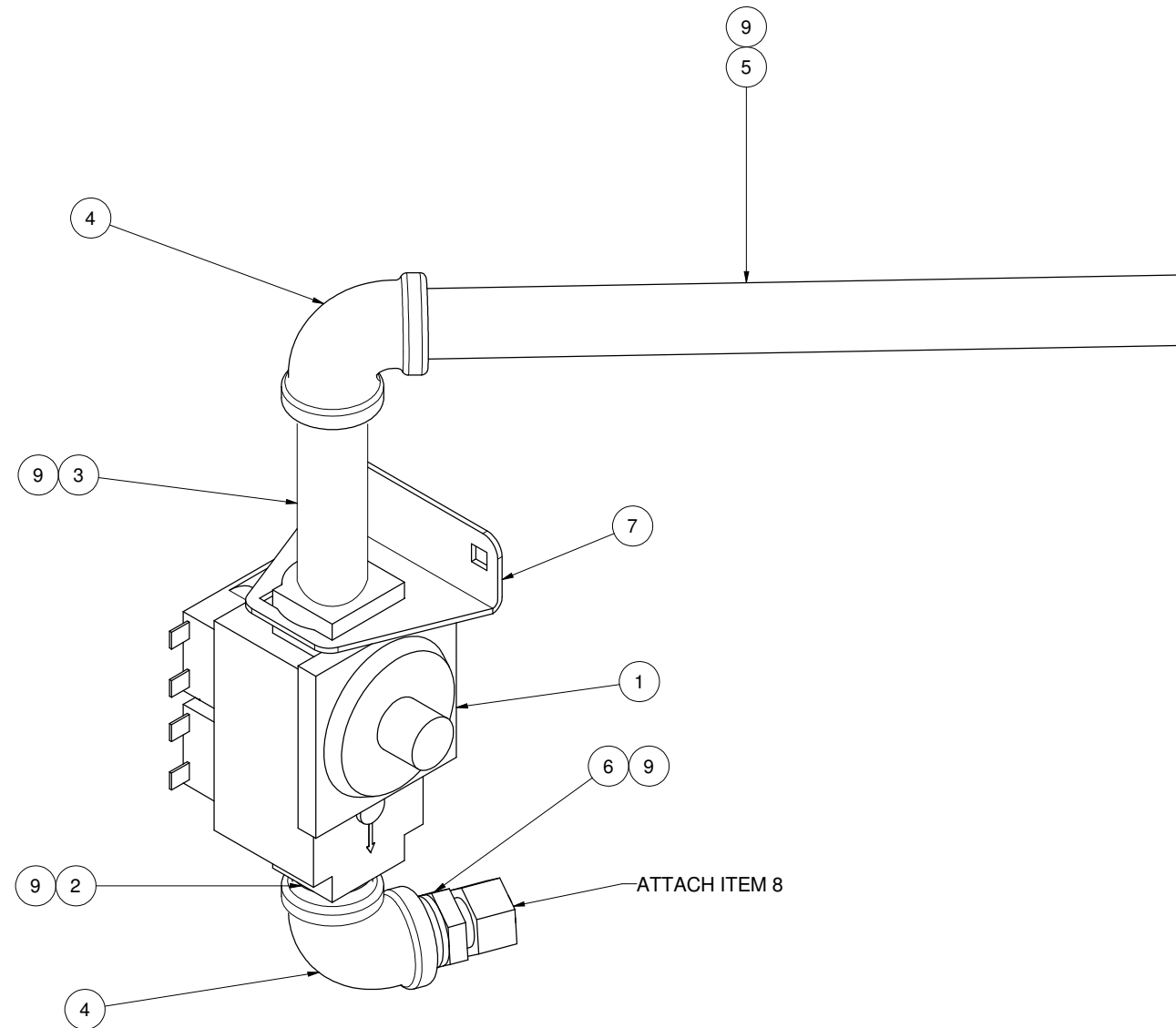

ITEM	QTY	PART NO.	DESCRIPTION
11	2	19170	SCREW, 1/4-20 X 5/8, HEX HD. SST
10	2	23105	WASHER, LOCK, 1/4, SST
9	A/R	00934	THREAD SEALANT
8	1	111101	GAS LINE, FLEXIBLE, .5 X 13.000 LONG, SST
7	1	111799	BRACKET, GAS VALVE MOUNT
6	1	06204	FTG., COMP. 1/2Tx1/2MPT PARKER HANIFIN 68CA-8-8
5	1	14441	NIPPLE, .50 NPT X 9.50 SCH. 40, BLK, TBE
4	2	05249	ELBOW, 90 DEG., 1/2" BLK
3	1	14333	NIPPLE .50 NPT X 3.50 SCH 40, BLK, IRN, TBE
2	1	14323	NIPPLE, 1/2 x CLOSE, BLACK
1	1	111814	VALVE, GAS, NATURAL, COMBINATION, 1/2" NPT, 24VAC

NOT SHOWN

CLEVELAND RANGE, LLC			
1333 East 179th St., Cleveland, Ohio 44110-2574			
THIS DESIGN DESCRIBES A PROPRIETARY ITEM AND IS THE PROPERTY OF CLEVELAND RANGE. THIS DRAWING IS NOT TO BE COPIED OR USED WITHOUT THE APPROVAL OF CLEVELAND RANGE.			
TOLERANCES (UNLESS OTHERWISE NOTED)	DO NOT SCALE PRINTED DRAWING	DRAWN BY LPH	DATE 3/1/2006
DECIMAL ± 0.030	TITLE GAS VALVE ASSY, NAT, CHEF 3/6 HL		
ANGULAR ± 1°	SIZE C	DRAWING NO. 111890	SHEET 1 OF 1 REV A

ASSEMBLY NOTE:

1. GIVEN DIMENSIONS ARE REFERENCE ONLY UNLESS OTHERWISE NOTED.
2. THREAD ENGAGEMENT USED FOR THIS ASSEMBLY IS 0.500"

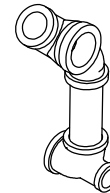
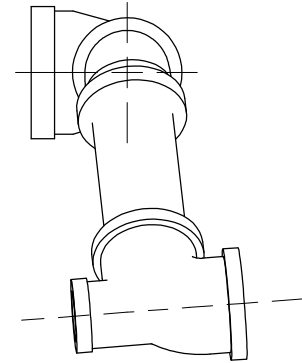
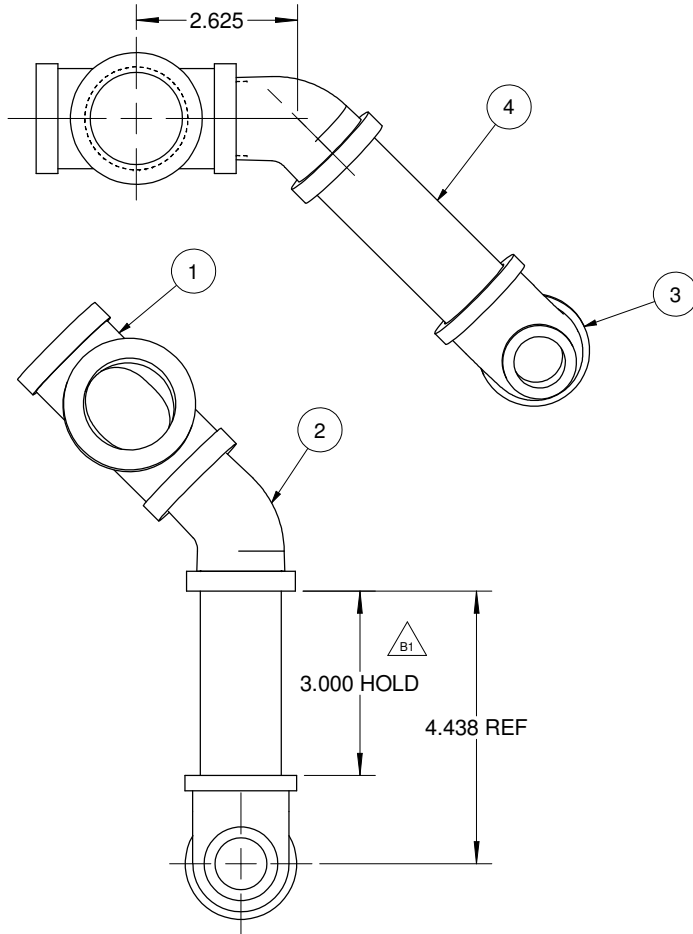

LET.	DESCRIPTION	DATE	BY
A	PRODUCTION RELEASE PER ECR-07-172	4-25-07	IG
B	1) DIM WAS 2.800 *PER ECR-07-257*	06-07-07	LPH

ITEM	QTY	PART NO.	DESCRIPTION
5	A/R	00934	SEALANT, PIPE DOPE
4	1	14494	NIPPLE, 1.00 NPT X 4.00 SCH. 40, BRASS, TBE
3	1	111153	TEE, 1" X 1/2" X 1", BRASS
2	1	111874	ELBOW, 1.00 NPT X 45 DEG. STREET, BRASS
1	1	111877	TEE, 1" X 1" X 1-1/4", BRASS

CLEVELAND RANGE, LLC
1333 East 179th St., Cleveland, Ohio 44110-2574

THIS DESIGN DESCRIBES A PROPRIETARY ITEM AND IS THE PROPERTY OF CLEVELAND RANGE. THIS DRAWING IS NOT TO BE COPIED OR USED WITHOUT THE APPROVAL OF CLEVELAND RANGE.

TOLERANCES (UNLESS OTHERWISE NOTED)	DO NOT SCALE PRINTED DRAWING	DRAWN BY LPH	DATE 2/20/2006
DECIMAL ± 0.030	TITLE DRAIN ASSEMBLY, STEAMCHEF, HL		
ANGULAR ± 1°	SIZE B	DRAWING NO. 111886	SHEET 1 OF 1 REV B

NOTE:
1. ITEM 21 IS PART OF THE LABEL PACKAGE.

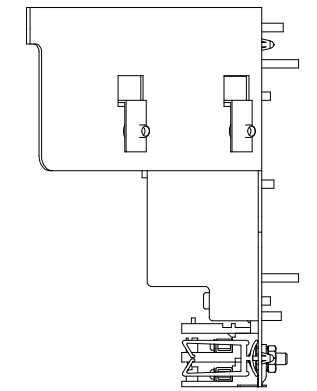
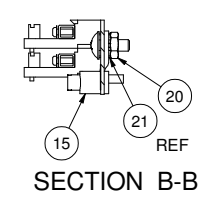
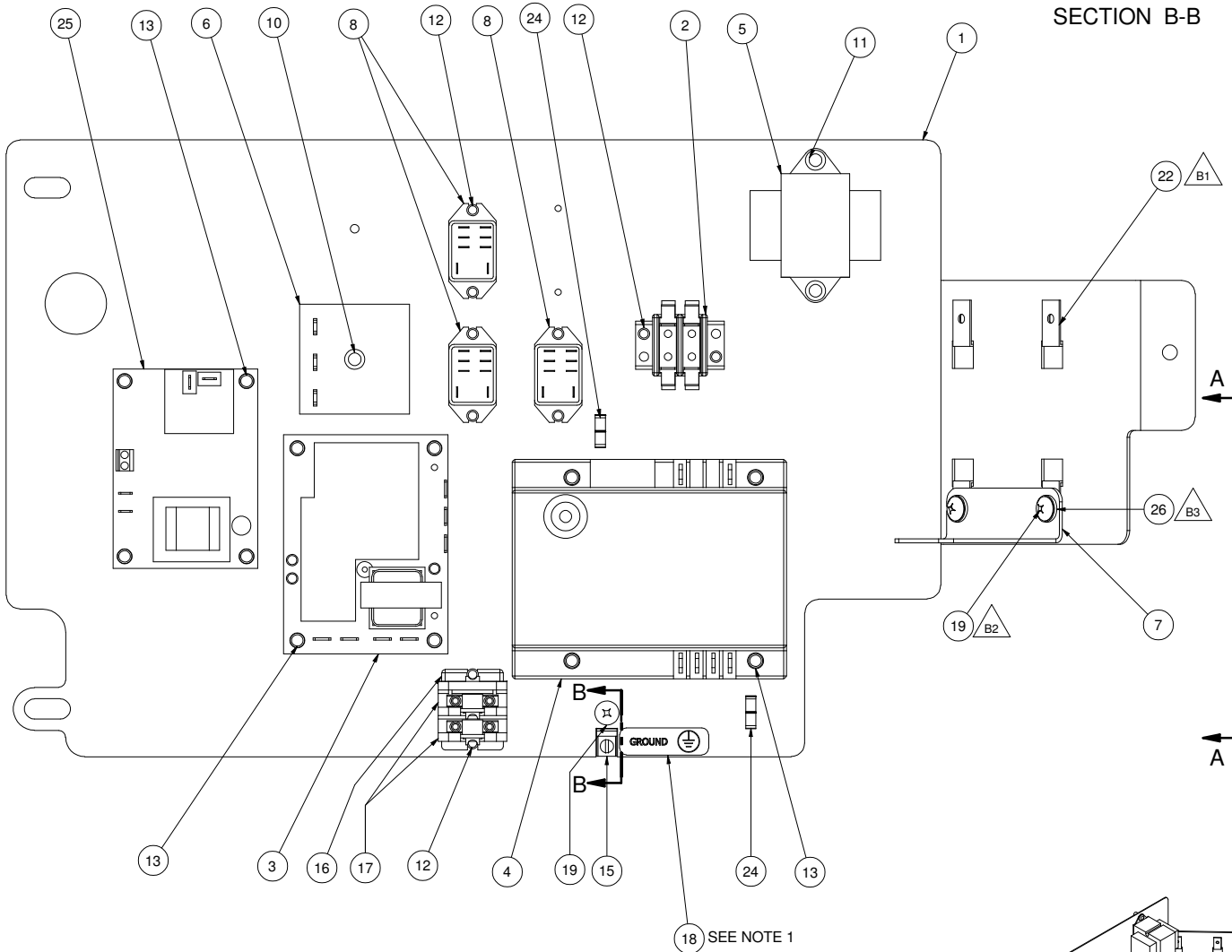

LET.	DESCRIPTION	DATE	BY
A	PRODUCTION RELEASE PER ECR-07-172	4-26-07	IG
B	PICTORIAL UPDATE, B1) ITEM 22 WAS 110581, WAS QTY 2	6-06-07	TJW
-	B2) REPLACE ITEMS 9, 108644 WITH ITEMS 19, B3) ADD ITEMS	-	-
-	26, B4) RMVD ITEMS 14 (14618) & 23 (23105); *PER ECR-07-257*	-	-

ITEM	QTY	PART NO.	DESCRIPTION
26	2	23105	WASHER, LOCK, 1/4" KATLINK STYLE, SST
25	1	300678	BOARD, SINGLE CHANNEL TEMPERATURE CONTROL
24	2	108612	CLIP, WIRE, VERTICAL, 0.740" X 0.420"
22	4	108734	NUT, "U" TYPE (EXTRUDED) #10-24 UNC-2B THREAD
21	2	23144	WASHER, LOCK, EXTERNAL TOOTH, #10 SST
20	1	14659	NUT, HEX, #10-24, SST
19	3	101231	SCREW, 10-24 X 0.500 SST, PHILLIPS TRUSS HEAD
18	1	14897	LABEL, GROUND
17	2	20301	TERMINAL SECTION, MARATHON
16	1	20302	TERMINAL, END SECTION
15	1	20304	LUG, GROUND
13	12	106128	SCREW, 6-32 X 1 TORX/PAN HD
12	10	106127	SCREW, 6-32 X 1/2, TORX/PAN HD
11	2	106123	SCREW, 10-32 X 1/2, TORX/PAN HD, THRD FORMING, ZN
10	1	106124	SCREW, TORX/SLOT #10-32 X 1-1/4 LG
8	3	105966	RELAY, DPDT-W/MTG TABS
7	1	111799	BRACKET, GAS VALVE MOUNT
6	1	20478	TIMER, SOLID STATE INTERV 3 MINUTE
5	1	20528	TRANSFORMER, 120-24V, 40VA, 50/60 HZ, 6" LEADS
4	1	03546	IGNITION, MODULE, CONTROL DIRECT SPARK, 4 SECOND
3	1	107241	BOARD, WATER LEVEL CONTROL
2	1	44168	TERMINAL, BLOCK ASM, 2 POLE
1	1	111800	COMPONENT PANEL, STEAMCHEF-GAS

CLEVELAND RANGE, LLC
1333 East 179th St., Cleveland, Ohio 44110-2574

THIS DESIGN DESCRIBES A PROPRIETARY ITEM AND IS THE PROPERTY OF CLEVELAND RANGE. THIS DRAWING IS NOT TO BE COPIED OR USED WITHOUT THE APPROVAL OF CLEVELAND RANGE.

TOLERANCES (UNLESS OTHERWISE NOTED)	DO NOT SCALE PRINTED DRAWING	DRAWN BY LPH	DATE 1/12/2006
DECIMAL ± 0.030	TITLE COMPONENT PANEL ASSEMBLY, STEAMCHEF 3 & 6 GAS		
ANGULAR ± 1°	SIZE C	DRAWING NO. 111802	SHEET 1 OF 1 REV B

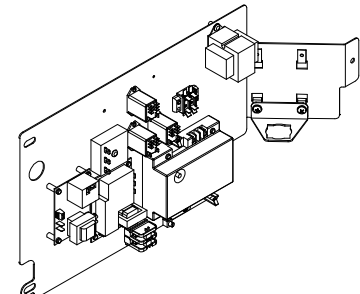

NOTE:
ITEM 4 IS INSTALLED UNDERNEATH ITEM 7, (2) PLCS.

LET.	DESCRIPTION	DATE	BY
A	PRODUCTION RELEASE PER ECR-07-172	4-26-07	IG

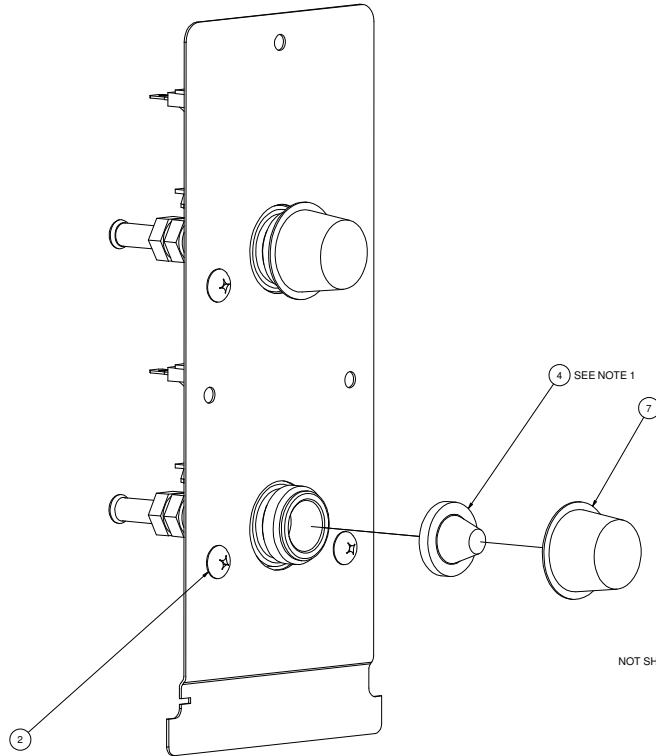
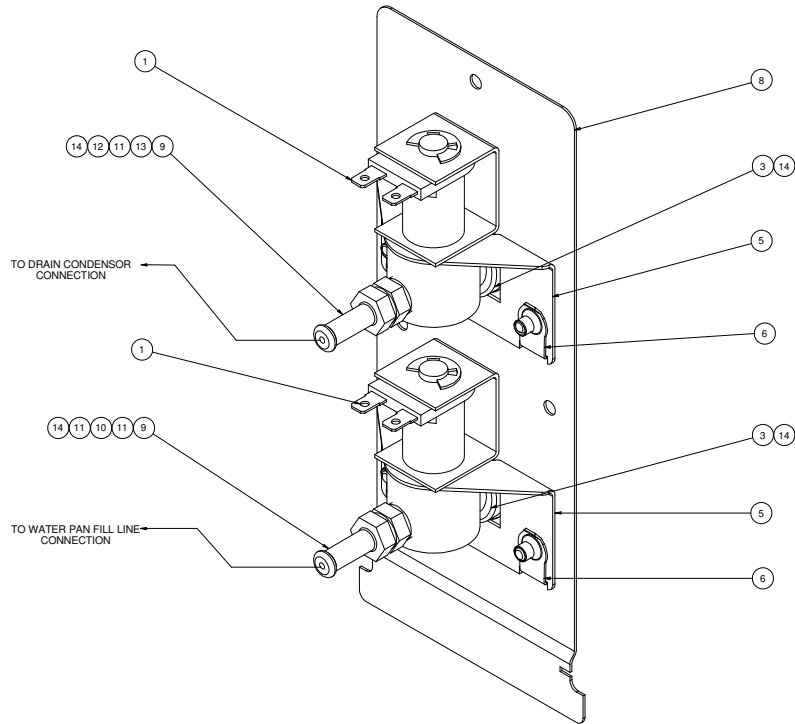

NOT SHOWN

14	1	00591	SEALANT, PIPE DOPE
13	1	105501000	HOSE, 1/4"X1/2" SILICONE, REINFORCED
12	1	105259	CLAMP, NORM DRV, 1/4"AL, 5/16" WIDE
11	3	1073121	CLAMP, HOSE, 1/4" ID, METAL TENSION BAND
10	1	105801100	HOSE, 1/4" ID, 11.000' LG, SILICONE, REINFORCED
9	2	1008001	FLOW RESTRICTOR, JAG, FOR 1/4" ID HOSE
8	1	111944	COVER PLATE, WATER INLET, CHEF 3.8 GAS
7	2	111113	CAP, NON THREADED, PROTECTOR
6	4	100704	NUT, 1/4" TYPE (EXTRUDED) #14-18 UNC-2B THREAD
5	2	110364	BRACKET, VALVE MOUNT STEAM/HEAT
4	2	110367	STRAINER, FILTER WASHER, GARDEN HOSE INLET
3	2	110321	FITTING, 1/4-18 NPT X 3/4-11 NH
2	4	104231	SCREW, 10-24 X 0.500 SST, PHILLIPS TRUSS HEAD
1	2	22218	VALVE, SOLENOID, 1/4" NORM, 120 VOL.
ITEM	QTY	PART NO.	DESCRIPTION

CLEVELAND RANGE, LLC			
<small>1833 East 79th St., Cleveland, Ohio 44116-2514</small>			
<small>DESIGNED BY: J. G. HARRIS / DRAWN BY: J. G. HARRIS / CHECKED BY: J. G. HARRIS</small>			
YOUNG & RUBICAM ARCHITECTURE SERIES	DATE PLOTTED 10/27/2004	DRAWN BY D. Peterson	DATE 10/27/2004
TITLE ± 0.030	WATER VALVE ASSEMBLY, CHEF 3.8 GAS		
ANGULAR ± 1°	SIZE D	DRAWING NO. 111383	SHEET 1 OF 1 REV A

NOTE:
FOR CORRECT ORIFICE PART NUMBER SEE WORK ORDER FOR SPECIFIC UNIT.

LET.	DESCRIPTION	DATE	BY
A	PRODUCTION RELEASE PER ECR-07-172	4-27-07	IG
B	CORRECTED PRODUCTSTREAM LINK AND ADDED PIPE DOPE	06-06-07	RS
-	IN PARTS LIST PER ECR-07-252	-	-

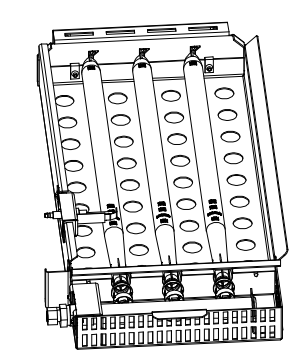
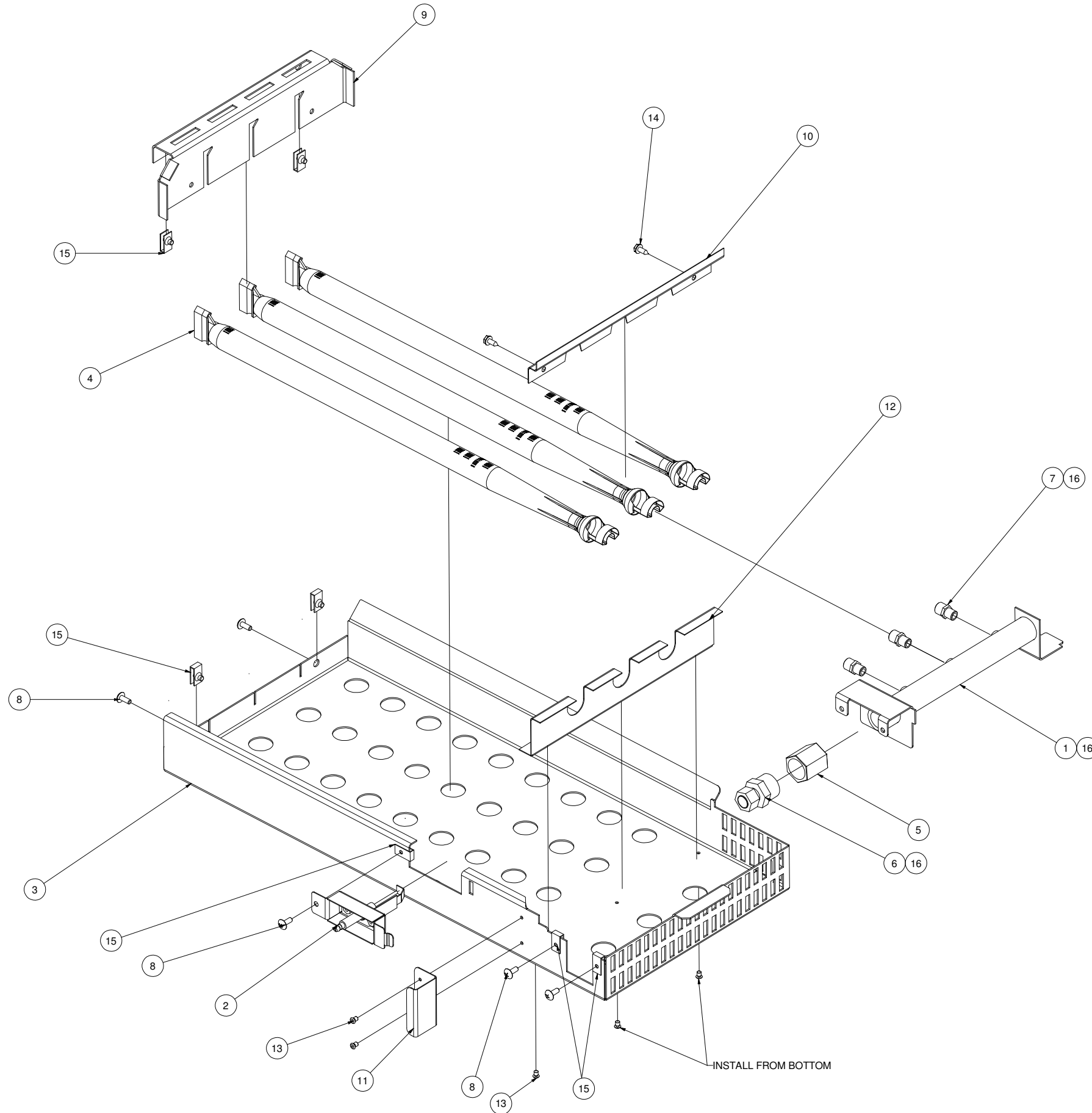

SEE NOTE

ITEM	QTY	PART NO.	DESCRIPTION
16	AR	00834	SEALANT, PIPE DOPE
15	7	108734	NUT, "U" TYPE (EXTRUDED) #10-24 UNC-2B THREAD
14	2	19148	SCREW, HEX WASHER HD, #10 x 1/2, TYPE AB, ZINC PLTD
13	5	18357	RIVET, FLUSH BREAK, 0.125 DIA, 0.128X0.187 GRIP, SST
12	1	111813	BAFFLE, AIR, BURNER SURROUND, H.L.
11	1	111811	BAFFLE, AIR, BURNER BOX RIGHT SIDE
10	1	111772	LOCK BAR, BURNER TUBE, CHEF, GAS, H.L.
9	1	111506	END CAP, BURNER TRAY
8	5	101231	SCREW, 10-24 X 0.500 SST, PHILLIPS TRUSS HEAD
7	3	111820	ORIFICE, BLANK, BECKETT BURNER
6	1	06206	COMPRESSION FTG
5	1	03612	COUPLING, FULL, 3/4", BR.
4	3	111355	BURNER, BECKETT, TUBE, 1", GAS BASE AND STEAMCHEF
3	1	111333	BURNER TRAY, CHEF 3.6 GAS, H.L.
2	1	111896	IGNITOR ASSY, GAS CHEF
1	1	111373	GAS MANIFOLD WELDMENT, H.L.

CLEVELAND RANGE, LLC				
1333 East 179th St., Cleveland, Ohio 44110-2574				
THE DESIGN DESCRIBED IS A PROPRIETARY ITEM AND IS THE PROPERTY OF CLEVELAND RANGE. THIS DRAWING IS NOT TO BE COPIED OR USED WITHOUT THE APPROVAL OF CLEVELAND RANGE.				
TOLERANCES (UNLESS OTHERWISE NOTED)	DO NOT SCALE PRINTED DRAWING	DRAWN BY	DATE	
DECIMAL ± 0.030		IG	4/27/2007	
ANGULAR ± 1°	SIZE D	DRAWING NO. 111329	SHEET 1 OF 2	REV B

NAT

USED ON PRODUCT LINE
22CGT6 - C255, 0 - 1,999FT
22CGT6 - C256, 2,000 - 4,999FT
22CGT6 - C257, 5,000 - 5,999FT
22CGT6 - C258, 6,000 - 7,999FT
22CGT6 - C259, 8,000 - 9,999FT
22CGT6 - C260, 9,000 - 10,999FT

22CGT6

P/N:	DESCRIPTION	HOLE SIZE
111844	ORIFICE, #44 DMS , BECKETT	#44 (0.086±0.001 REF)
111845	ORIFICE, #45 DMS , BECKETT	#45 (0.082±0.001 REF)
111846	ORIFICE, #46 DMS , BECKETT	#46 (0.081±0.001 REF)
111847	ORIFICE, #47 DMS , BECKETT	#47 (0.079±0.001 REF)
111848	ORIFICE, #48 DMS , BECKETT	#48 (0.076±0.001 REF)
111849	ORIFICE, #49 DMS , BECKETT	#49 (0.073±0.001 REF)
111855	ORIFICE, #55 DMS , BECKETT	#55 (0.052±0.001 REF)
111856	ORIFICE, #56 DMS , BECKETT	#56 (0.047±0.001 REF)
111857	ORIFICE, #57 DMS , BECKETT	#57 (0.043±0.001 REF)

LP

CHECK WITH PIN GAUGES
22CGT6 - C271, 0 - 4,999FT
22CGT6 - C272, 5,000 - 9,999FT
22CGT6 - C273, 10,000 - 10,999FT

NAT

USED ON PRODUCT LINE
22CGT3 - C249, 0 - 1,999FT
22CGT3 - C250, 2,000 - 4,999FT
22CGT3 - C251, 5,000 - 7,999FT
22CGT3 - C252, 8,000 - 10,999FT

22CGT3

P/N:	DESCRIPTION	HOLE SIZE
111849	ORIFICE, #49 DMS , BECKETT	#49 (0.073±0.001 REF)
111850	ORIFICE, #50 DMS , BECKETT	#50 (0.070±0.001 REF)
111851	ORIFICE, #51 DMS , BECKETT	#51 (0.067±0.001 REF)
111852	ORIFICE, #52 DMS , BECKETT	#52 (0.064±0.001 REF)
1118561	ORIFICE, 1.15mm , BECKETT	1.15mm (0.045±0.001 REF)
111857	ORIFICE, #57 DMS , BECKETT	#57 (0.043±0.001 REF)
111858	ORIFICE, #58 DMS , BECKETT	#58 (0.042±0.001 REF)
111859	ORIFICE, #59 DMS , BECKETT	#59 (0.041±0.001 REF)
111860	ORIFICE, #60 DMS , BECKETT	#60 (0.040±0.001 REF)
111861	ORIFICE, #61 DMS , BECKETT	#61 (0.039±0.001 REF)

LP

CHECK WITH PIN GAUGES
22CGT3 - C263, 0 - 2,999FT
22CGT3 - C264, 3,000 - 5,999FT
22CGT3 - C265, 6,000 - 6,999FT
22CGT3 - C266, 7,000 - 8,999FT
22CGT3 - C267, 9,000 - 9,999FT
22CGT3 - C268, 10,000 - 10,999FT

LET.	DESCRIPTION	DATE	BY
A	PRODUCTION RELEASE "PER ECR-07-172"	05-02-07	TJW

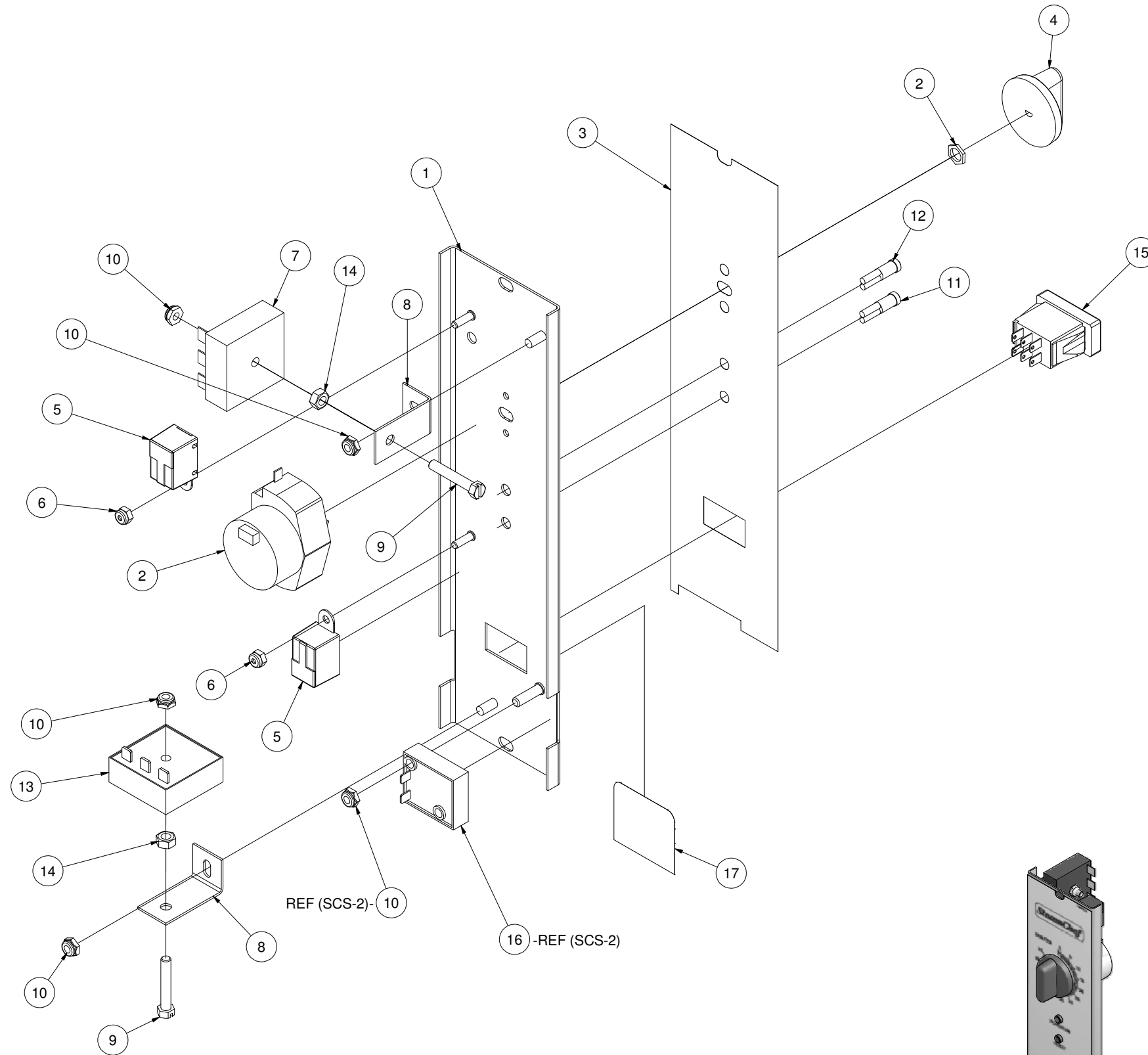

NOT SHOWN {
REF

19	6	20351	TERMINAL, SIPHON FULL-INSUL.
18	1	300333	HARNES, MECH TIMER PANEL
17	1	109153	LABEL, SLIP IN, MODEL NUMBER / SERIAL NUMBER
16	1	108880	SWITCH, DOOR STEAM CUTOFF
15	1	104224	SWITCH, ROCKER DPDT, MATTE
14	2	14817	NUT, HEX 1/4-20 STEEL OXIDE FINISH
13	1	300150	TIMER, SOLID STATE, 60 MINUTE FIXED DELAY
12	1	109494	LIGHT, GREEN INDICATOR, NEON, 120V
11	1	12159	LIGHT, INDICATOR, NEON, RED, 7" MIN LEAD LENGTH
10	5	101873	NUT, HEX 1/4-20 THIN LOCK, ZINC PLTD. STEEL
9	2	19175	SCREW, HEX HD, NON-SLTD FULL THRD 1/4-20x1.50 ZNC PLTD
8	2	105955	BRACKET, DUAL TIMER MOUNTING
7	1	20477	TIMER, SOLID STATE, 3 SEC DELAY ON BREAK
6	2	14692	NUT, HEX, 10-24, ELASTIC LOCK, ZINC PLTD, FASTENER
5	2	41350	BUZZER, ASSY, CONTINUOUS DUTY, 120VAC, 50-60HZ
4	1	110661	KNOB, EAGLE TIMER
3	1	1106672	LABEL, CONTROL PANEL, MECH.
2	1	110198	TIMER, MOTOR DRIVEN, 60 MIN. 115V 60HZ
1	1	111451	PANEL, CONTROL, WELDM., MECH. TIMER, STEAMCHEF, HL
ITEM	QTY	PART NO.	DESCRIPTION

CLEVELAND RANGE, LLC
1333 East 179th St., Cleveland, Ohio 44110-2574

THIS DESIGN DESCRIBES A PROPRIETARY ITEM AND IS THE PROPERTY OF CLEVELAND RANGE.
THIS DRAWING IS NOT TO BE COPIED OR USED WITHOUT THE APPROVAL OF CLEVELAND RANGE.

TOLERANCES (UNLESS OTHERWISE NOTED)	DO NOT SCALE PRINTED DRAWING	DRAWN BY TJW	DATE 5/2/2007
DECIMAL ± 0.030	TITLE PANEL ASSY, MECH. TIMER, CHEF, GAS-HL		
ANGULAR ± 1°	SIZE C	DRAWING NO. 3003312	SHEET 1 OF 1 REV A

STEAMCHEF 3 / 6 MECH TIMER (GAS)

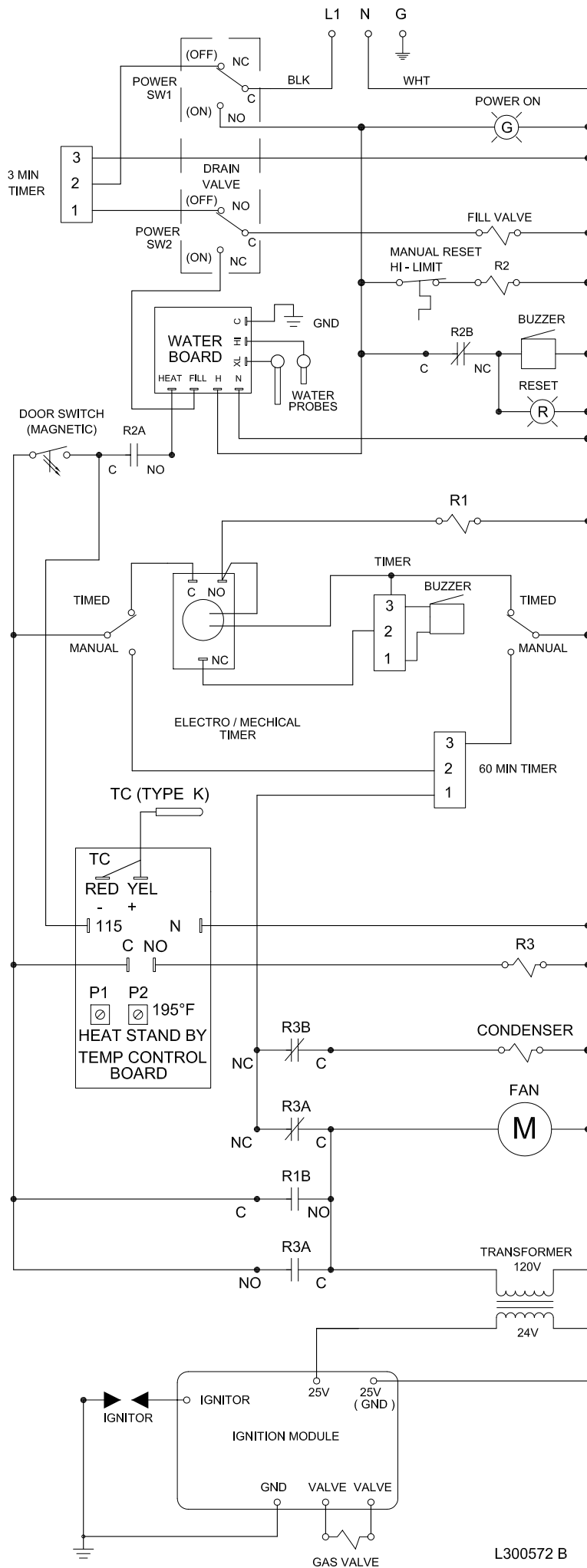

STEAMCHEF 3 / 6 ELECTRONIC TIMER (GAS)

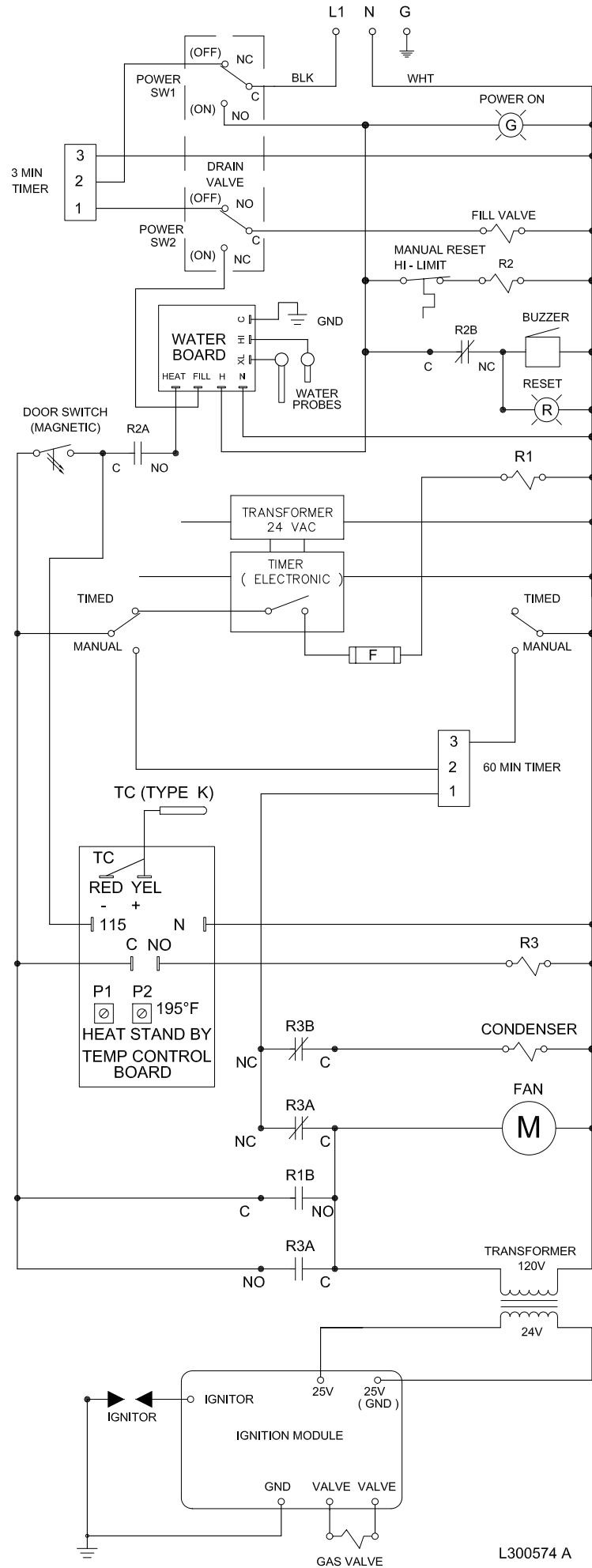

STEAMCHEF 3 / 6 ON/OFF CONTROL (GAS)

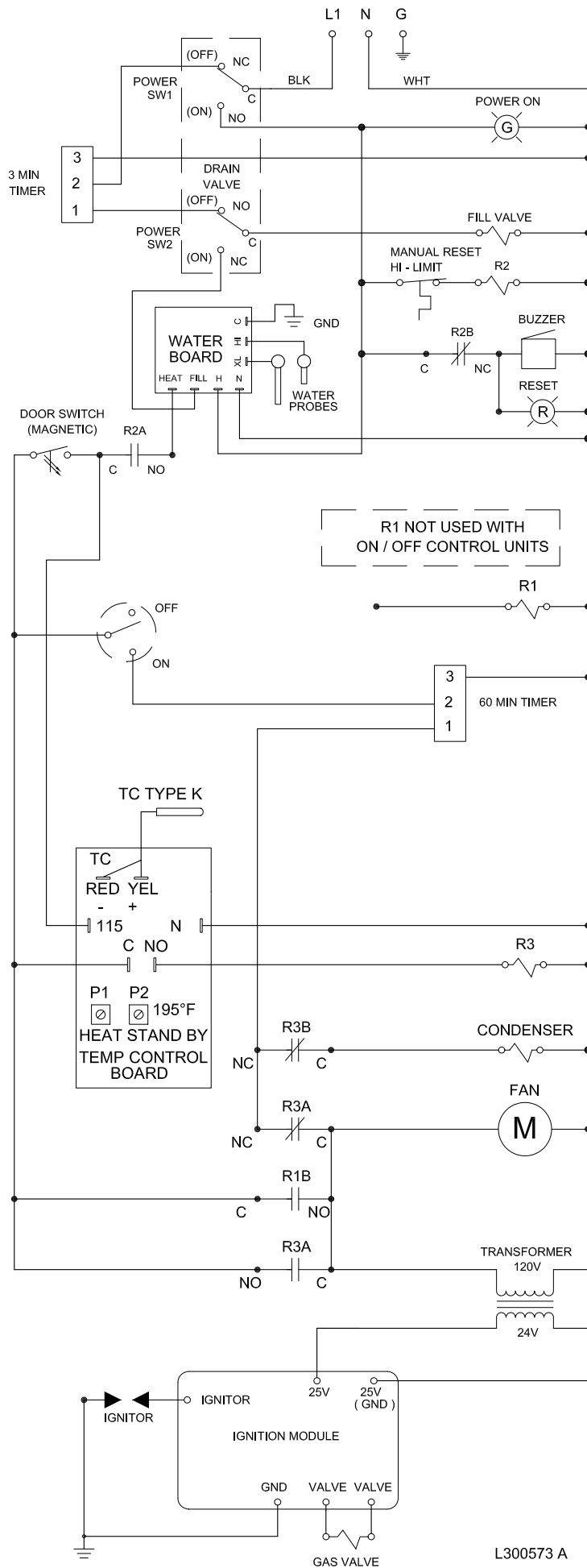

STEAMCHEF 3 / 6 ON/OFF CONTROL (GAS)

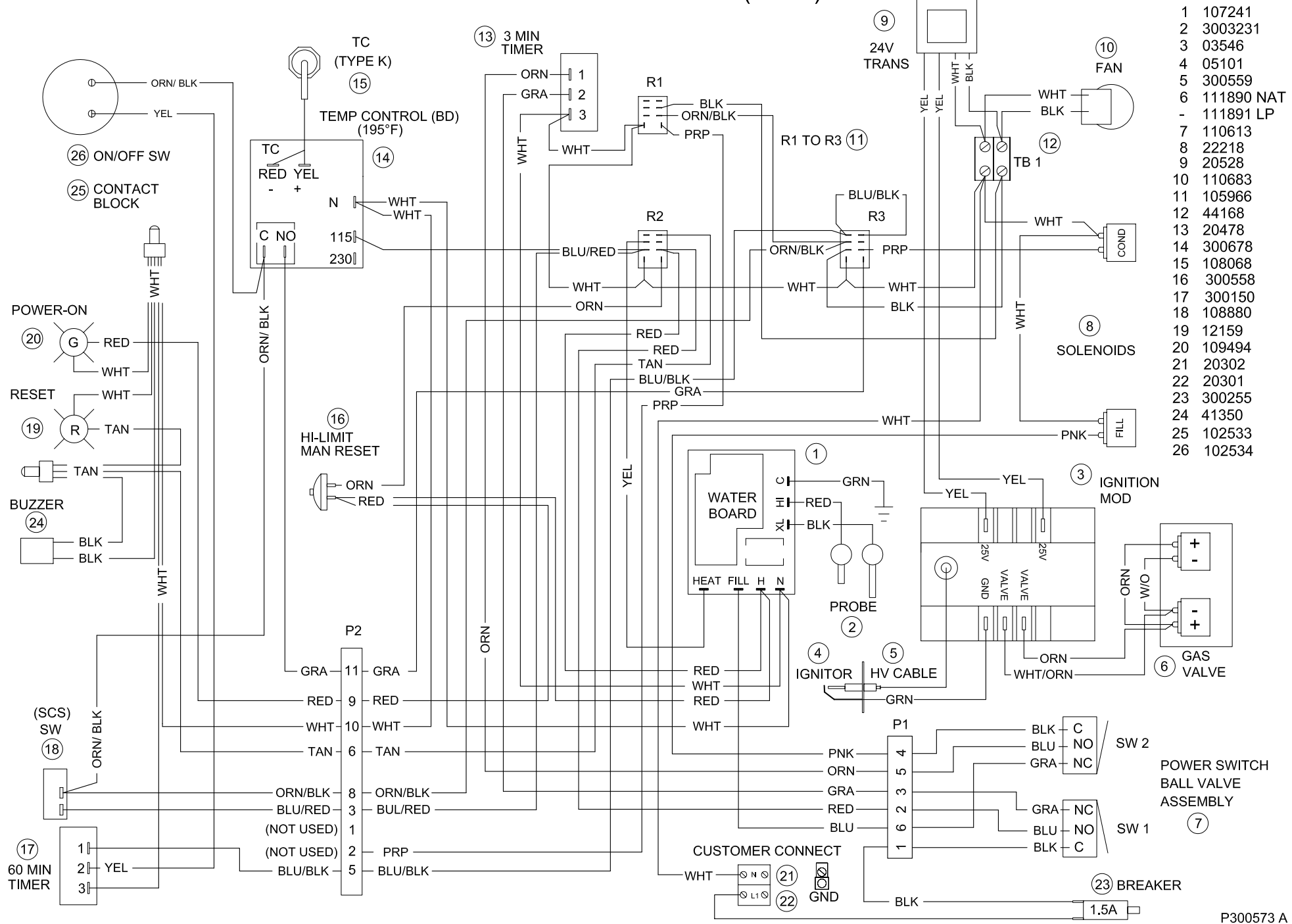

ITEM	PART No.
1	107241
2	3003231
3	03546
4	05101
5	300559
6	111890 NAT
-	111891 LP
7	110613
8	22218
9	20528
10	110683
11	105966
12	44168
13	20478
14	300678
15	108068
16	300558
17	300150
18	108880
19	12159
20	109494
21	20302
22	20301
23	300255
24	41350
25	102533
26	102534