

Parts Manual

Counter Type Electric Convection Steamer



Series: SteamCraft Models 21CET16

1333 East 179th Street
Cleveland, Ohio 44110

Phone: (216) 481-4900
1-800-338-2204

Fax: (216) 481-3782
www.clevelandrange.com

 Cleveland

NOTES:

- 1.1 SEE INSTRUCTION DRAWING 104283 FOR LABEL LOCATIONS.
- 2.1 SEE INSTRUCTION DRAWING 1065572 FOR HOSE LOCATIONS.
- 3.1 REVISION SYMBOLS (A) ARE PLACED NEXT TO AFFECTED ITEM NO. IN BILL OF MATERIALS ONLY.
- 4.1 FOR STEAM SHUT-OFF SWITCH OPTION SEE DRAWING 106586 FOR LOCATION OF HOLES IN FACEPLATE AND DRAWING 106355 FOR PICTORIAL WIRING INFO.

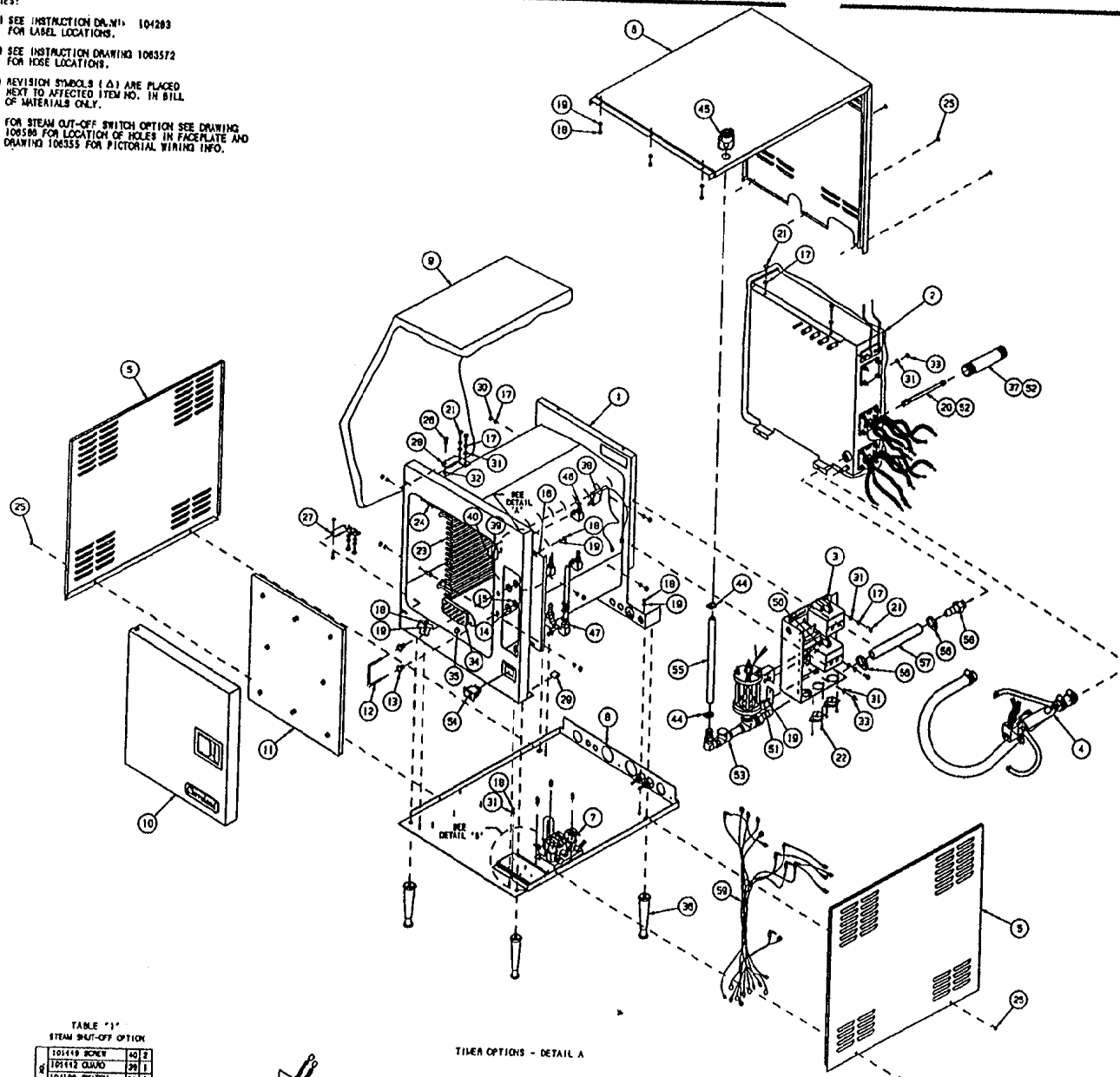

LET.	REVISIONS	DATE	BY
A	UPDATED PER VARIOUS E.O.'S PER EO 10-2732	11-02-94	PJO

ITEM NO.	QTY.	PART NO.	DESCRIPTION
59	-	106359	WIRE HARNESS, MECHANICAL, SC 3/5
-	-	106358	WIRE HARNESS, ELECTRONIC, SC 3/5
58	1	06240	FITTING, 3/4 H X 3/4 NPT
57	1	1060931100	HOSE, SILICONE 3/4 ID X 1 OD X 11
56	2	105847	CLAMP, PLASTIC 1-1/8 OD HOSE
55	1	1044681200	HOSE, SILICONE 1/2 ID X 3/4 OD X 12
54	1	19994	SWITCH, ROCKER, SPST (CLEAN LIGHT)
53	1	108487	FLOAT AND DESCALER ASSEMBLY, SC 5.1
52	A/R	00934	SEALANT, RECTORSEAL
51	3	14892	NUT, HEX LOCK ELASTIC 10-24
50	3	19287	SCREW, PAN HEAD 10-24 X 1/2, S/S
49	-	108433	HEAT STANDBY PLATE
48	-	108433	INT. BLOWDOWN/HEAT STANDBY PLATE
47	1	19972	THERMAL SWITCH
46	3	1070591	BREATHER/SPRAY NOZZLE ASSEMBLY
45	1	1062301	SPRAY NOZZLE ASSEMBLY
44	2	105878	CLAMP, PLASTIC, 3/4" O.D. HOSE
43	-	23134	WASHER, FLAT, 5/16
42	-	23120	WASHER, FLAT, 3/8 X 7/8
41	-	104409	CLOSURE, THERMAL OPENING
40	-	105449	SCREW, TRUSS HD. 8-32 X .312, S/S
39	-	105442	GUARD, SWITCH PROTECTION
38	-	104198	SWITCH ASSY, C&P; STEAM SHUT-OFF
37	1	104185	HIPPLE, 1-1/4 X 8-1/2, BLACK
36	4	1014501	LEG, ADJUSTABLE, PLASTIC, 4"
35	1	14877	NUT, ACORN
34	1	69298	SCREEN, COMPARTMENT DRAIN
33	3	14885	NUT, HEX, ELASTIC LOCK, 1/4-20
32	2	104082	RING, SNAP, S/S
31	13	23116	WASHER, FLAT, 1/4 X 5/8, S/S
30	8	14818	NUT, HEX 1/4-20, S/S
29	2	234321	D-CLIP, SMALL
28	1	1040732	HINGE ASSY, WELD, UPPER
27	1	1040731	HINGE ASSY, WELD, BOTTOM
26	2	104077	PIN, HINGE
25	7	104080	SCREW, TRUSS HD. SMT. MET., #8 X 1/2
24	8	101305	PIN, RACK
23	2	41423	RACK, PAN SLIDE, 20"
22	4	108127	SCREW, TORX #8 X 1/2, SELF-TAPPING
21	8	19170	SCREW, HEX HEAD 1/4-20 X .625, S/S
20	1	104840	NOZZLE, ASSEMBLY
19	12	101855	WASHER, PLAT #10, S/S
18	11	14872	NUT, HEX LOCK 10-32
17	17	23105	WASHER, LOCK, 1/4" RATLINK, S/S
-	-	108305	PANEL, CONTROL ASSY, ON/OFF
-	-	104191	PANEL, CONTROL ASSY, MECHANICAL
-	-	104238	PANEL, CONTROL ASSY, ELECTRONIC
15	2	14878	NUT, LOCK 1/2-13 PREVAILING TORQUE
14	2	23149	WASHER-NYLON, TYPE 8/8
13	2	14898	NUT, DOOR CATCH MOUNTING, S/S
12	1	104048	CATCH, DOOR
11	1	104202	DOOR ASSY, INNER, H.L.
10	-	1085751	DOOR ASSY, H.L. W/LOGO, W/ACTUATOR
-	-	108575	DOOR ASSY, H.L. W/LOGO
9	1	104193	INSULATION, CUT, SC 5.1
8	1	104098	BASE, WELD ASSEMBLY, SC 3.1/SC 5.1
7	1	108522	VALVE ASSEMBLY, WATER INLET
6	1	104037	SHEETING, TOP/BACK, SC 5.1 H.L.
5	2	104038	SHEETING, SIDE, SC 5.1
4	1	108524	VALVE ASSEMBLY, DRAIN, SC 3.1 & 5.1
3	1	104200	COMPONENT PANEL ASSY, SC 5.1 H.L.
2	1	104194	GENERATOR ASSEMBLY, SC 5.1 H.L.
1	1	1041971	CAVITY, WELD ASSY, SC 5.1 H.L.

TABLE 11
STEAM SHUT-OFF OPTION

104119	SCREW	40	2
104142	GUARD	26	1
104198	SWITCH	58	1
104202	DOOR-HL	11	1
108731	DOOR-CUT	10	1

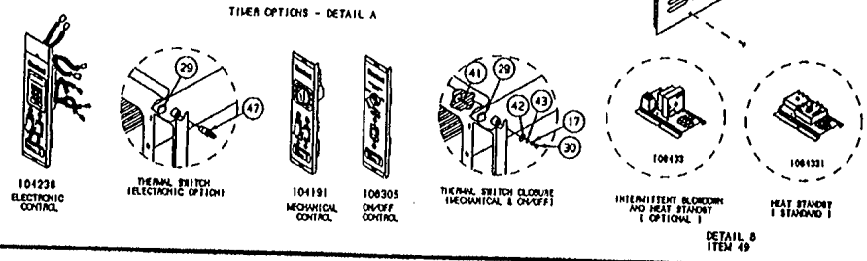

THIS DESIGN DESCRIBES A PROPRIETARY ITEM AND IS THE PROPERTY OF CLEVELAND RANGE. THIS DRAWING IS NOT TO BE COPIED OR USED WITHOUT THE APPROVAL OF CLEVELAND RANGE.

TOLERANCES (EXCEPT AS NOTED)			
CLEVELAND RANGE INC. 1333 East 179th St. Cleveland, Ohio 44110-2574			
DECIMAL ± N/A	SCALE 7/8" = 1"	DRAWN BY DUTCHMAN	APPROVED BY
ANGULAR ± N/A	TITLE STEAMCRAFT ULTRA 5, ELECTRIC, H.L. FINAL ASSEMBLY, ALL OPTIONS		
CK	DATE 07-13-93	DRAWING NO. C - 106609	REV. A

NOTES:

1.) SEE INDIVIDUAL ASSEMBLY DRAWINGS

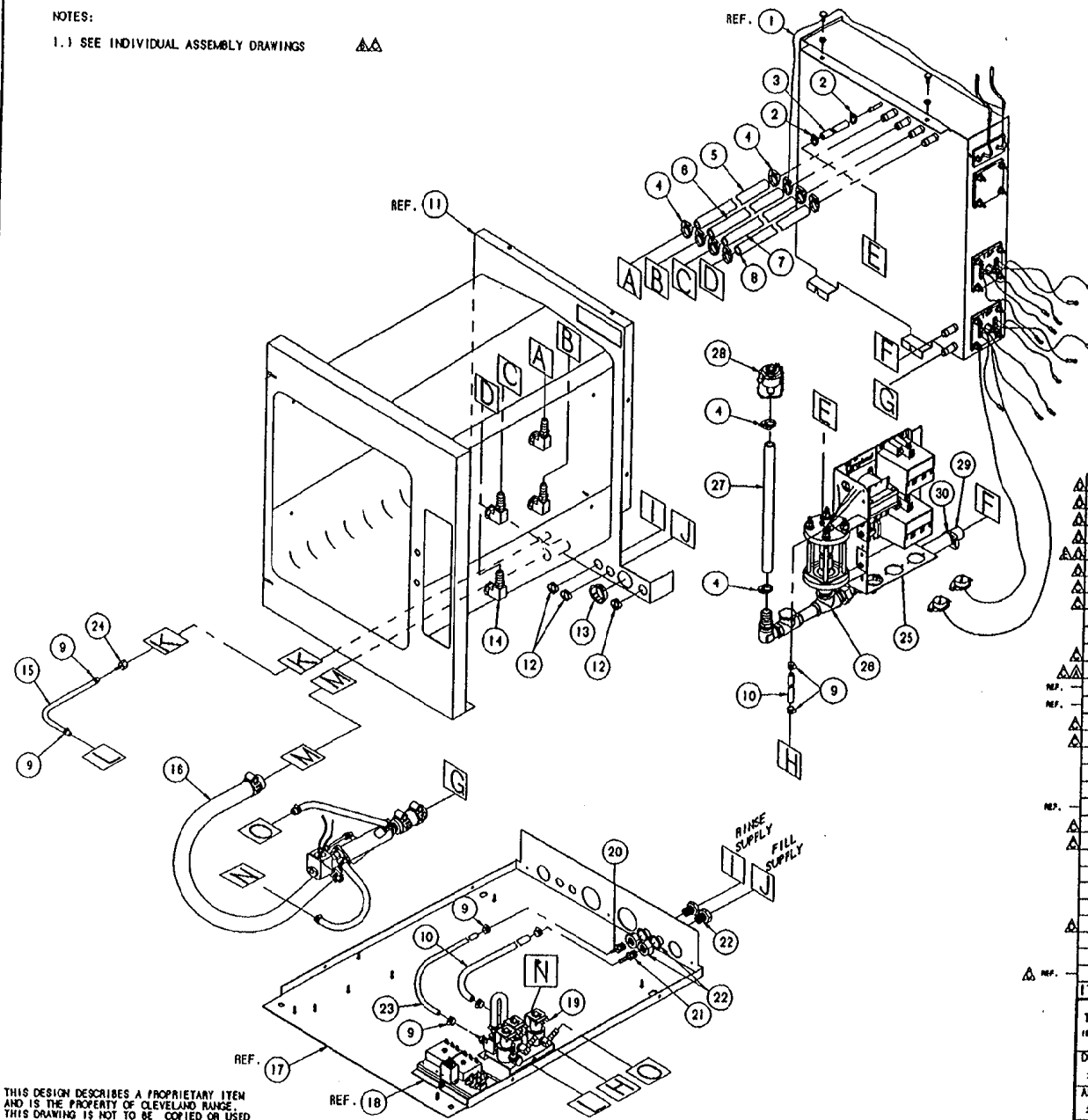

THIS DESIGN DESCRIBES A PROPRIETARY ITEM AND IS THE PROPERTY OF CLEVELAND RANGE. THIS DRAWING IS NOT TO BE COPIED OR USED WITHOUT THE APPROVAL OF CLEVELAND RANGE.

LET.	REVISIONS	DATE	BY
A	RESTRAINT & BREATHER HOSE ASSY. ADDED AND 104087 VALVE ASSY. REVISED PER E.O. KC-2451 AND KC-2451 R1	08-25-93	P.JD
B	ADDED NOTES 9 AND 4 PER E.O. KC-2451 R2	08-29-93	P.JD
C	REMOVED RESTRAINT & BREATHER HOSE ASSY AND REMOVED NOTES 2-4 AND ADDED 1/8 ID HOSES & FITTINGS AND 108522 REPLACED 104087 AND 106526 REPLACED 108219 AND 108524 REPLACED 106384 PER EO KC-2492 R1	09-08-93	P.JD
D	REVISED GENERATOR AND ADDED 104200, 108521, 1058451200, 108428, 105847 & 1080931100 AND 105448 WAS QTY. OF 8 PER E.O. KC-2502 R1	09-20-93	P.JD
E	SEE E.O. KC-2502 R3	11-08-93	P.JD

Δ	30	2	105847	CLAMP, PLASTIC 1-1/8 HOSE
Δ	29	1	1080931100	HOSE, SILICONE 3/4 X 1.00 X 11 LG.
Δ	28	-	108428	PORT ASSY, DESCALER
Δ	27	1	1058451200	HOSE, NORPRENE 1/2 X 3/4 X 12 LG.
Δ	26	-	108487	FLOAT/DESCALER ASSY, SC 5.1
Δ	25	-	104200	COMPONENT PANEL ASSY, SC 5.1
Δ	24	1	108682	FITTING, HOSE 1/8 H X 1/8 FPT, STR
Δ	23	1	1088842100	HOSE, NT-80, 1/8 X 3/8 X 21" LG.
Δ	22	2	03641	COUPLING, BULKHEAD, 1/4 IPS, BRASS
Δ	21	1	104381	FITTING, HOSE 1/4 X 1/4 H, STR
Δ	20	1	106681	FITTING, HOSE 1/8 H X 1/4 MPT, BRASS
Δ	19	1	108522	VALVE ASSEMBLY, WATER INLET
REF.	18	-	-	PLATE, TDS & SBY, STEAMCRAFT
REF.	17	-	-	BASE, WELD ASSEMBLY
Δ	16	1	106524	VALVE ASSEMBLY, DRAIN
Δ	15	1	1088842800	HOSE, NT-80, 1/8 X 3/8 X 28" LG.
Δ	14	4	1082301	SPRAY NOZZLE ASSEMBLY, STEAMCRAFT
Δ	13	1	102581	HEYCO BUSHING, INSULATOR, 7/8"
Δ	12	3	02800	HEYCO BUSHING SB-875-11, INSULATOR
REF.	11	-	-	CAVITY, WELD ASSEMBLY
Δ	10	2	1058501900	HOSE, NT-80, 1/4 X 1/2 X 19 LG.
Δ	9	8	106526	HOSE CLAMP, METAL, 3/8 X 5/8 X 5/16
Δ	8	1	1058452700	HOSE, NORPRENE, 1/2 X 3/4 X 27" LG.
Δ	7	1	1058452000	HOSE, NORPRENE, 1/2 X 3/4 X 20" LG.
Δ	6	1	1058452200	HOSE, NORPRENE, 1/2 X 3/4 X 22" LG.
Δ	5	1	1058451800	HOSE, NORPRENE, 1/2 X 3/4 X 18" LG.
Δ	4	10	105848	HOSE CLAMP, NYLON, 3/4" OD HOSE
Δ	3	1	1058432200	HOSE, NORPRENE, 1/4 X 1/2 X 22" LG.
Δ	2	2	104383	HOSE CLAMP, NYLON, 1/2" OD HOSE
REF.	1	-	-	GENERATOR ASSEMBLY

ITEM	QTY.	PART NO.	DESCRIPTION
TOLERANCES (EXCEPT AS NOTED)			
CLEVELAND RANGE INC.			
1333 East 179th St. Cleveland, Ohio 44110-2574			
DECIMAL	SCALE	DRAWN BY	APPROVED BY
± N/A	3/16"	DUTCHMAN	MLT
ANGULAR	TITLE		
± N/A	HOSE DETAIL STEAMCRAFT 5.1		
DATE	DRAWING NO.	REV.	
CK 05-18-93	C - 1063572	E	

NOTES:

1. SEE WIRING DIAGRAM 104185 FOR WIRE CONNECTION POINTS.

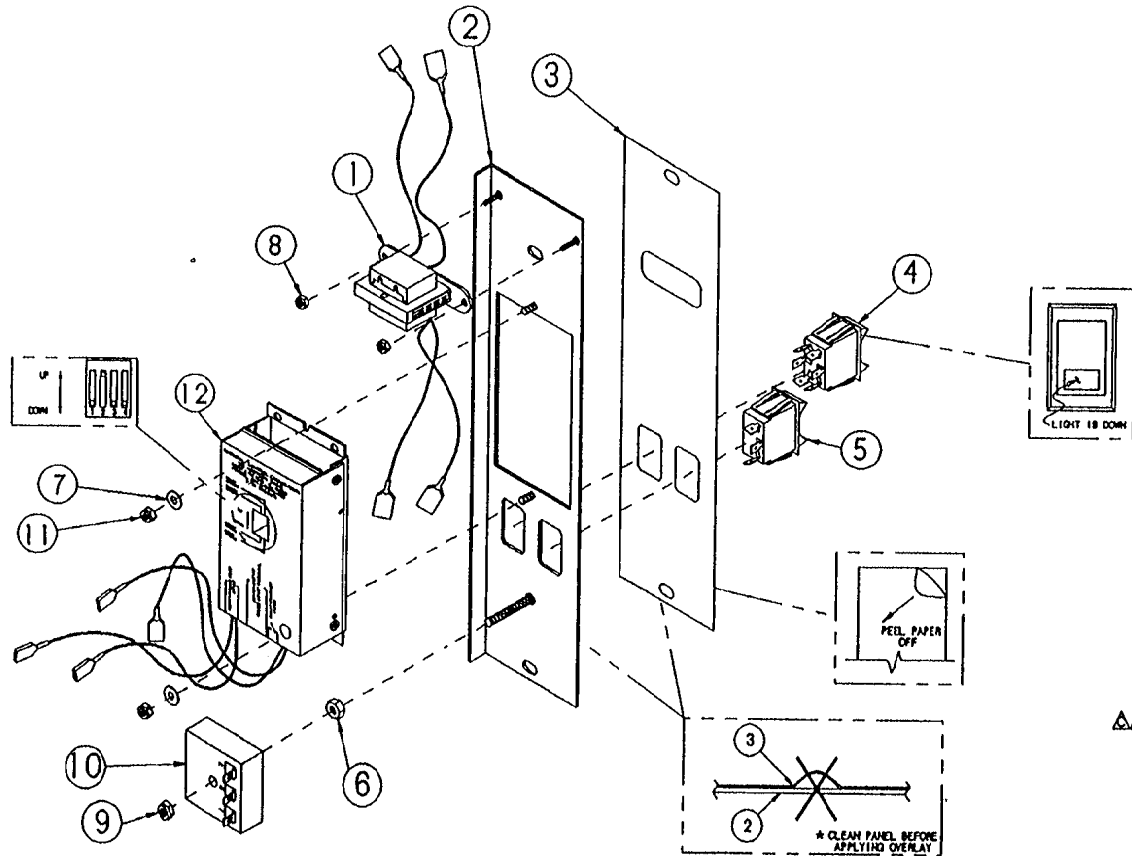

LET.	REVISIONS	DATE	BY
A	P/N 104389 WAS REVISED PER EO IC-1781	09-15-90	RJOS
B	P/N 104572 WAS 104051, P/Ns 101855 & 104223 WERE QTY. OF 4, REMOVED RELAY ITEMS 03524, 03525, 101855, 104223, 1041290200 AND PICTORIAL CHANGES TO P/Ns 104157, 104572 & 1040071 PER EO IC-1878	01-23-91	PJO
C	ADDED TERMINALS TO P/N 104390 & 104389, P/N 104389 WAS 1040071, P/N 104390 WAS 1040072 PER E.O. IC-1794 R1	05-09-91	PJO
D	P/N 108601 WAS P/N 104572 PER E.O. IC-2503	09-21-93	PJO

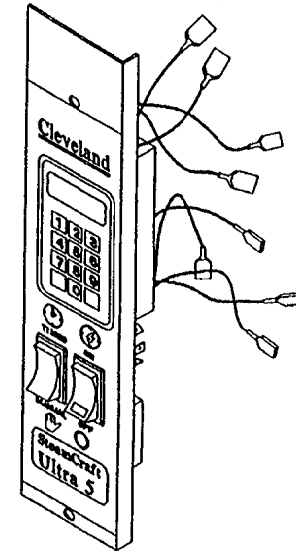

13	1	104164	HARNES, WIRING, ELEC. (NOT SHOWN)
12	1	104389	TIMER ASSEMBLY, NOC
11	2	14892	NUT, HEX 10-24 ELASTIC LOCK
10	1	20478	TIMER, SOLID STATE, 3-MINUTE
9	1	101873	NUT, HEX 1/4-20 ELASTIC LOCK
8	2	104223	NUT, HEX 6-32 ELASTIC LOCK
7	2	101855	WASHER, FLAT #10 S/S
6	1	14817	NUT, HEX 1/4-20 STEEL
5	1	104224	SWITCH, ROCKER, SPDT, MATTE
4	1	19993	SWITCH, ROCKER, DPDT, ON/OFF
3	1	108601	LABEL, CONTROL PANEL, ULTRA 5
2	1	104157	PANEL, CONTROL, WELDMENT
1	1	104390	TRANSFORMER ASSEMBLY
ITEM	QTY.	PART NO.	DESCRIPTION

TOLERANCES <small>(EXCEPT AS NOTED)</small>			
CLEVELAND RANGE INC. 1333 East 178th St. Cleveland, Ohio 44110-2574			
DECIMAL ± N/A	SCALE 1/2	DRAWN BY R. RIOS	APPROVED BY
ANGULAR ± N/A	TITLE CONTROL PANEL ASS'Y., ELECTRONIC STEAMCRAFT 5.1 ULTRA		
OK	DATE 09-11-90	DRAWING NO. C - 104238	REV. D

THIS DESIGN DESCRIBES A PROPRIETARY ITEM AND IS THE PROPERTY OF CLEVELAND RANGE. THIS DRAWING IS NOT TO BE COPIED OR USED WITHOUT THE APPROVAL OF CLEVELAND RANGE.

LET.	REVISIONS	DATE	BY
A	REMOVED ITEMS 5, 6, 8 & 9 AND REVISED ITEM 1 PICTORIAL PER E.O. #C-1876 R1	02-06-98	PD
B	SEE E.O. #C-1957 R1	07-31-91	PD
C	P/N 20478 ROTATED 90° AND P/N/S 41350 & 14872 MOVED FROM BOTTOM TO TOP OF P/N 104085 PER E.O. #C-2364 R3	08-25-93	PJ
D	P/N 106603 REPLACED P/N 103722 PER E.O. #C-2503	09-21-93	PD

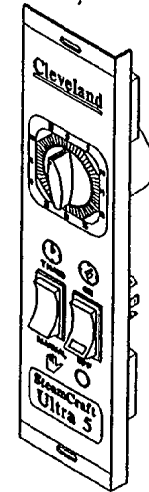
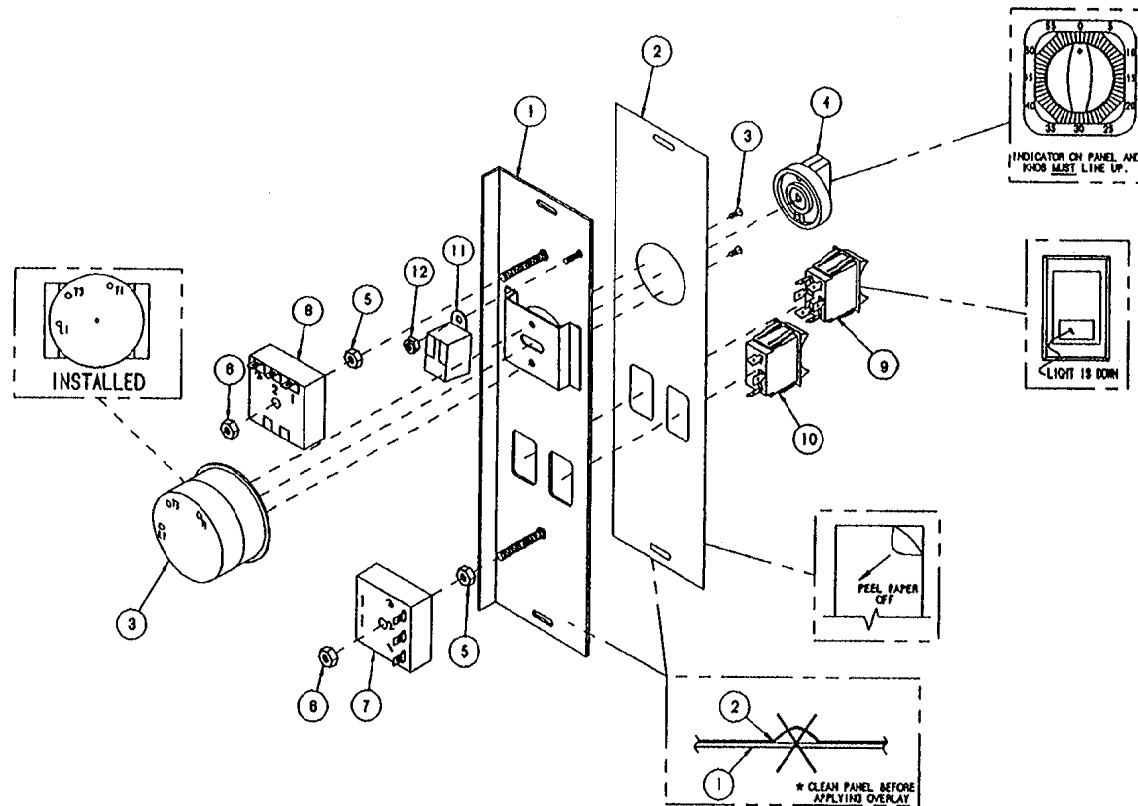

△	12	1	14872	NUT, HEX. LOCKING #10-32
△	11	1	41350	BUZZER
	10	1	104224	SWITCH, ROCKER, SPDT, MATTE
	9	1	19993	SWITCH, ROCKER, DPDT W/ RED LIGHT
△	8	1	20478	TIMER, 3-MINUTE
	7	1	20477	TIMER, 3-SECOND
	6	2	101873	NUT, HEX. ELASTIC LOCK 1/4-20
	5	2	14817	NUT, HEX. 1/4-20 BLACK OXIDE
△	4	1	11307	TIMER KNOB
	3	1	20476	TIMER WITH MOUNTING SCREWS (2)
△	2	1	108603	LABEL, CONTROL, MECHANICAL, ULTRA 5
△	1	1	104085	CONTROL PANEL WITH STUDS

ITEM	QTY.	PART NO.	DESCRIPTION
TOLERANCES EXCEPT AS NOTED			
CLEVELAND RANGE INC. 1330 East 179th St. Cleveland, Ohio 44110-2574			
DECIMAL ± N/A	SCALE 1/2	DRAWN BY R. RIOS	APPROVED BY
ANGULAR ± N/A	TITLE CONTROL PANEL ASS'Y., MECHANICAL STEAMCRAFT 5.1 ULTRA		
CK	DATE 07-09-90	DRAWING NO. C - 104191	REV. D

THIS DESIGN DESCRIBES A PROPRIETARY ITEM AND IS THE PROPERTY OF CLEVELAND RANGE. THIS DRAWING IS NOT TO BE COPIED OR USED WITHOUT THE APPROVAL OF CLEVELAND RANGE.

- NOTES : 1.) USE LOCTITE #222 - LOW STRENGTH (1#104146) ON ITEM 4
 2.) USE RTV (1#00933) ON ITEM 6
 3.) ORIENT LONGER SIDE OF ITEM 5 TOWARD HANDLE

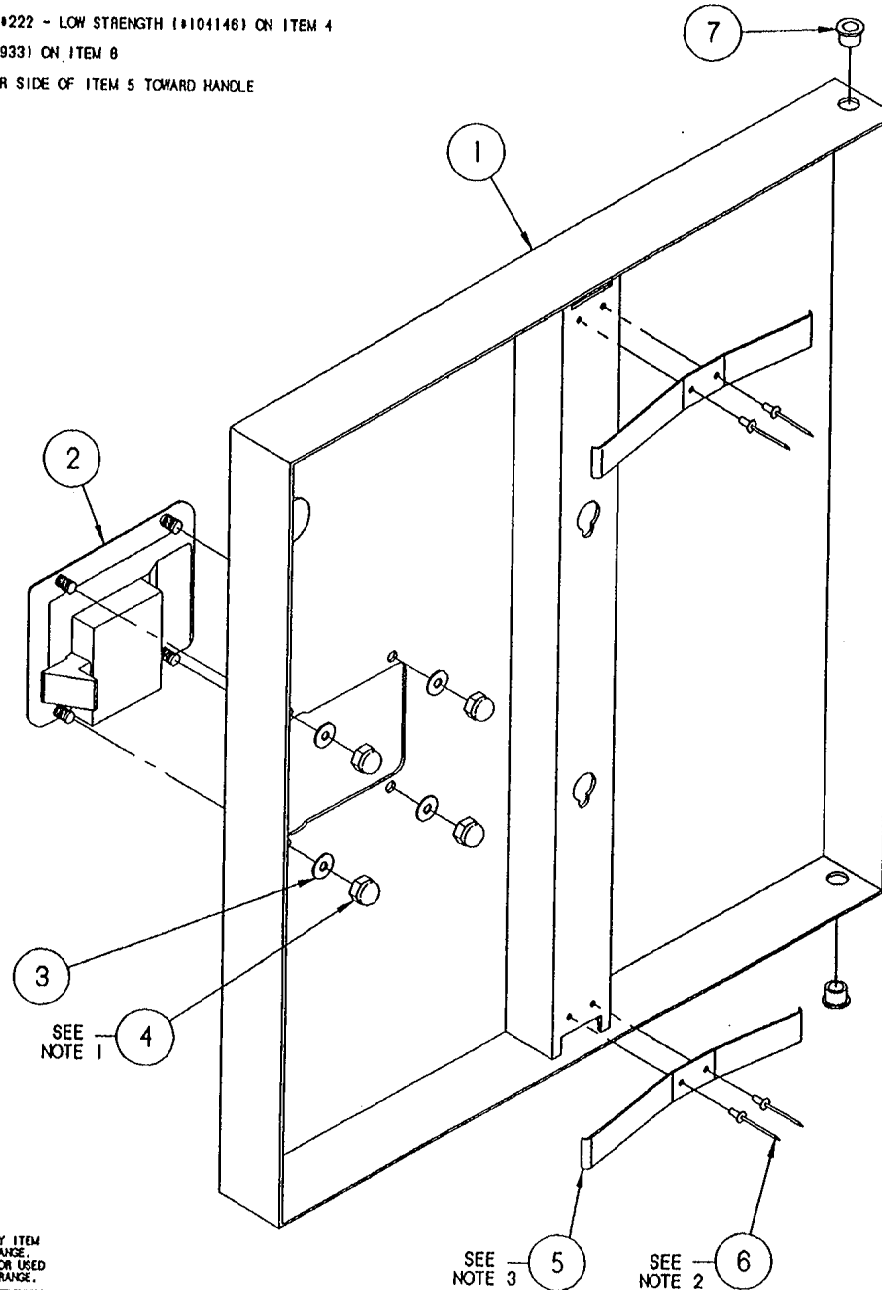

SEE NOTE 1

SEE NOTE 3

SEE NOTE 2

LET.	REVISIONS	DATE	BY
A	P/AS 105901 & 104987 ADDED, PICTORIAL CHANGE, REDRAWN CADKEY PER E.O. #C-2441 R2	08-30-93	PJD
B	P/AS 105901 & 104987 REF. ONLY PER E.O. #C-2441 R3	08-05-93	PJD
C	P/AS 105901 & 104987 REMOVED PER E.O. #C-2441 R5	12-13-93	PJD

ITEM	QTY.	PART NO.	DESCRIPTION
7	2	103641	BUSHING, BRONZE
6	4	18357	RIVET, 1/8" DIA. FLUSH BREAK, S/S
5	2	102228	SPRING, DOOR
4	4	14879	NUT, #10-24 ACORN, S/S
3	4	101655	WASHER, #10 FLAT, S/S
2	1	103843	LATCH, DOOR - PADDLE TYPE
1	1	1042072	DOOR, OUTER WELD ASSY, W/SCS TAB, S/C S.I., H.L.

TOLERANCES (EXCEPT AS NOTED)			
CLEVELAND RANGE INC. 1333 East 178th St. Cleveland, Ohio 44110-2574			
DECIMAL ± N/A	SCALE 5/8=1	DRAWN BY JTW	APPROVED BY
ANGULAR ± N/A	TITLE DOOR, OUTER ASSEMBLY, H.L. SC 5.1 CONV. W/ SWITCH ACTUATOR		
DATE 02-04-93	DRAWING NO. C - 1042062	REV. C	

THIS DESIGN DESCRIBES A PROPRIETARY ITEM AND IS THE PROPERTY OF CLEVELAND RANGE. THIS DRAWING IS NOT TO BE COPIED OR USED WITHOUT THE APPROVAL OF CLEVELAND RANGE.

NOTES:

- 1.) USE LOCKTITE #222 - LOW STRENGTH (#104146) ON ITEM 4
- 2.) USE RTV (#00933) ON ITEM 6
- 3.) ORIENT LONGER SIDE OF ITEM 5 TOWARD HANDLE

LET.	REVISIONS	DATE	BY
-	SEE E.O. #C-2411 R2	08-28-93	PJD
A	P/N'S 105901 & 104987 REF. ONLY AND MOVED TO UNDER DOOR LATCH PER E.O. #C-2411 R3	08-05-93	PJD
B	P/N'S 105901 & 104987 REMOVED PER E.O. #C-2411 R5	12-13-93	PJD

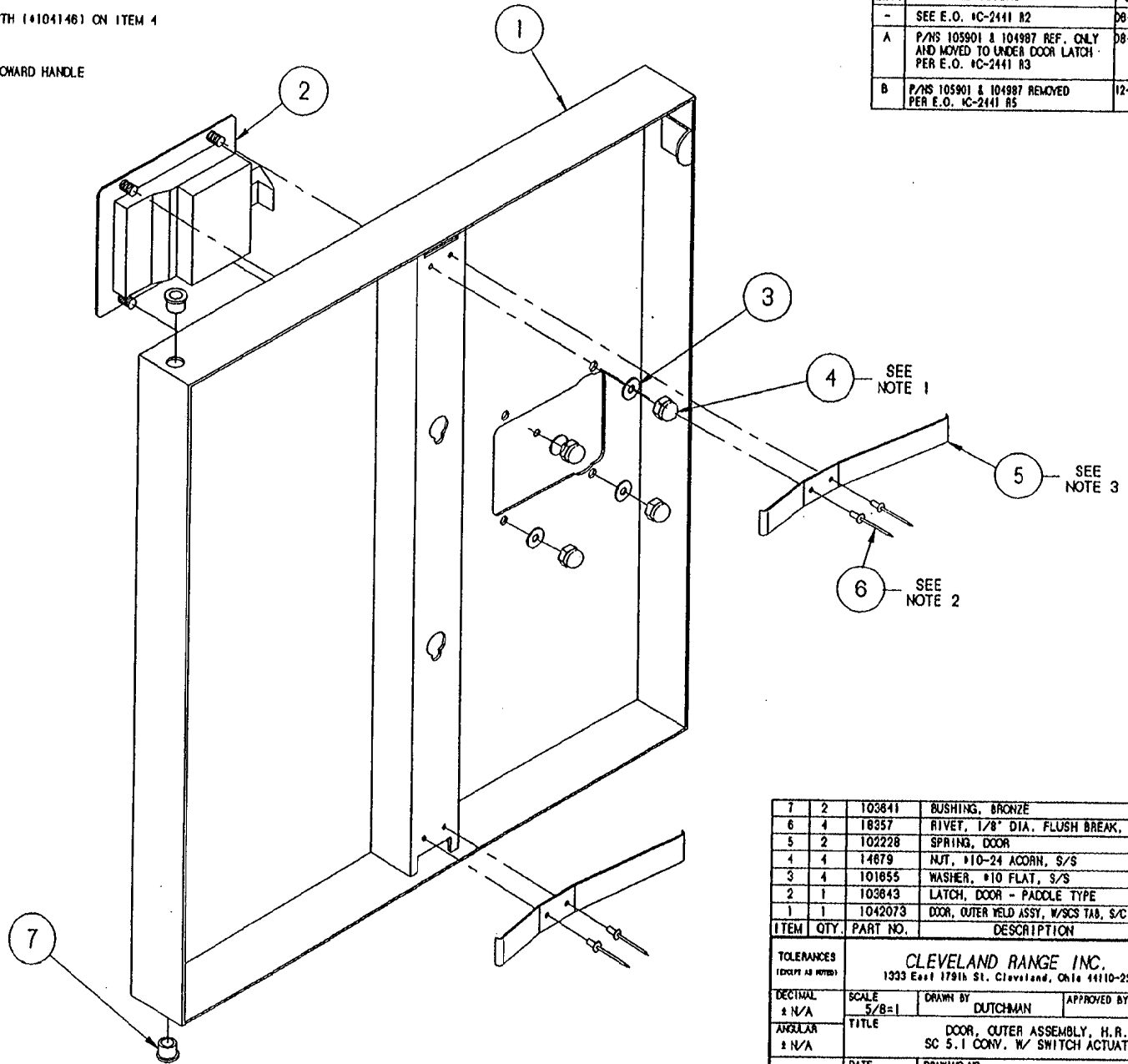

ITEM	QTY.	PART NO.	DESCRIPTION
7	2	103841	BUSHING, BRONZE
6	4	18857	RIVET, 1/8" DIA. FLUSH BREAK, S/S
5	2	102228	SPRING, DOOR
4	4	14679	NUT, #10-24 ACORN, S/S
3	4	101655	WASHER, #10 FLAT, S/S
2	1	103843	LATCH, DOOR - PADLOCK TYPE
1	1	1042073	DOOR, OUTER WELD ASSY, W/SCS TAB, S/C S.I., H.R.

TOLERANCES (EXCEPT AS NOTED)		CLEVELAND RANGE INC. 1333 East 179th St. Cleveland, Ohio 44110-2574	
DECIMAL ± N/A	SCALE 5/8=1	DRAWN BY DUTCHMAN	APPROVED BY
ANGULAR ± N/A	TITLE DOOR, OUTER ASSEMBLY, H.R. SC S.I CONV. W/ SWITCH ACTUATOR		
CK	DATE 08-30-93	DRAWING NO. C - 1042063	REV. 8

THIS DESIGN DESCRIBES A PROPRIETARY ITEM AND IS THE PROPERTY OF CLEVELAND RANGE. THIS DRAWING IS NOT TO BE COPIED OR USED WITHOUT THE APPROVAL OF CLEVELAND RANGE.

LET.	REVISIONS	DATE	BY
A	ADDED ITEMS 1 & 8, ITEM 2 WAS 104205	6/25/91	JPB

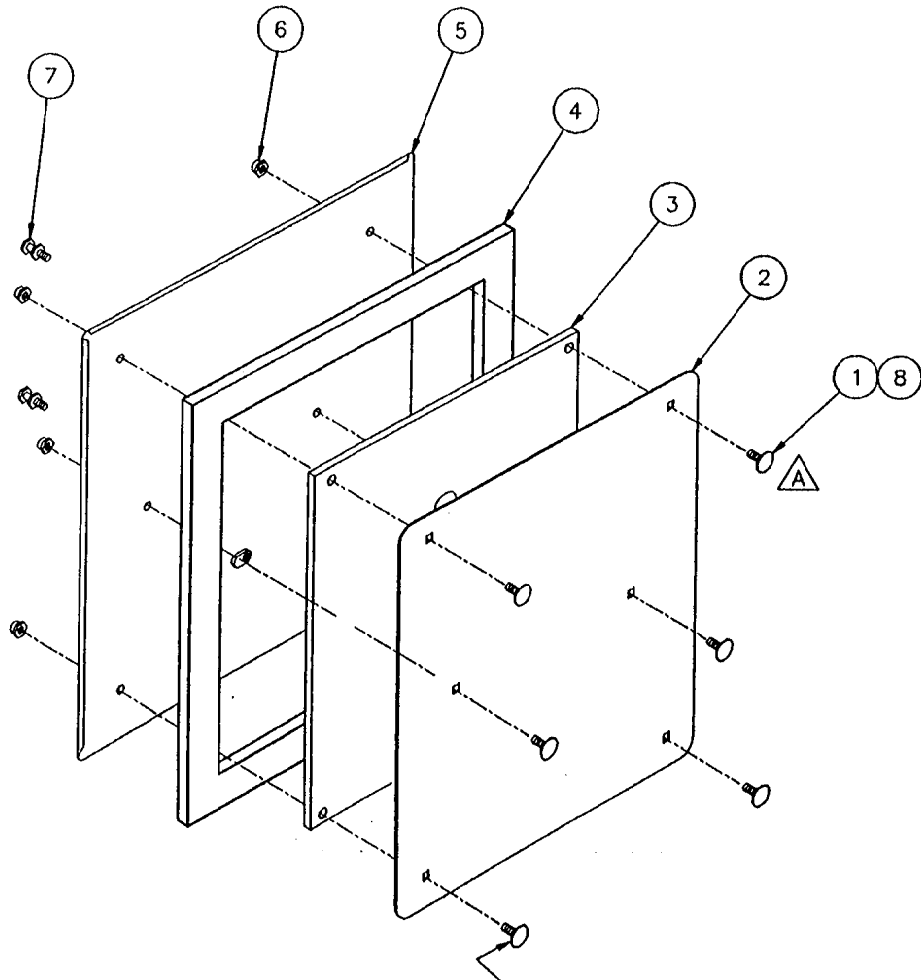

RTV APPLIED AROUND
SQ. ON BASE OF HEAD

ITEM	QTY	PART NO.	DESCRIPTION
8	A/R	00932	SEALANT, CLEAR RTV
7	2	66508	STUD, DOOR MOUNTING, INNER
6	6	14665	NUT, HEX LOCK, 1/4-20 S/S
5	1	104204	DOOR WELDMENT, INNER, S/C 5.1
4	1	104026	GASKET, DOOR S/C 5.1
3	1	104022	PLATE, INNER GASKET RETAINER, S/C 5.1
2	1	104021	PLATE, GASKET RETAINER, S/C 5.1
1	6	104719	BOLT, CARRIAGE 1/4-20 X 1.000"

A

CLEVELAND RANGE INC.			
1333 East 179th St. Cleveland, Ohio 44110-2574			
TOLERANCES (EXCEPT AS NOTED)	SCALE	DRAWN BY	APPROVED BY
DECIMAL ± -	NONE	JPB	
ANGULAR ± 1°	TITLE		
	DOOR, INNER ASSY. STEAMCRAFT 5.1		
AC	DATE	DRAWING NO.	REV
	6/25/91	B- 104202	A

THIS DESIGN DESCRIBES A PROPRIETARY ITEM AND IS THE PROPERTY OF CLEVELAND RANGE.
THIS DRAWING IS NOT TO BE COPIED OR USED WITHOUT THE APPROVAL OF CLEVELAND RANGE.

NOTE:

- 1) SEE DRAWING 1063572 FOR HOSE LOCATIONS.
- 2) ITEMS MARKED "REF" ARE INCLUDED IN THIS BILL OF MATERIALS FOR REFERENCE ONLY. THE "ASSEMBLED UNIT" DRAWING DEPICTS THE ACTUAL REQUIRED PARTS FOR THIS ASSEMBLY.

ASSEMBLED UNIT

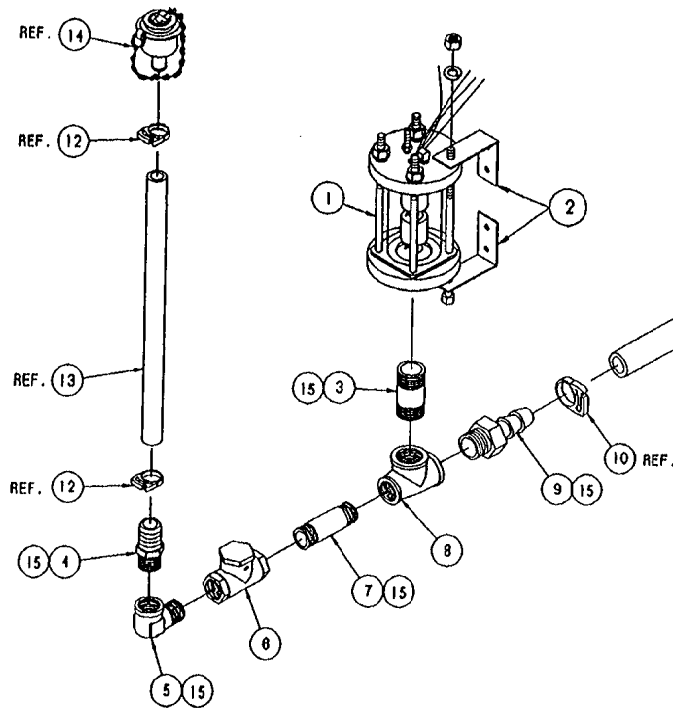
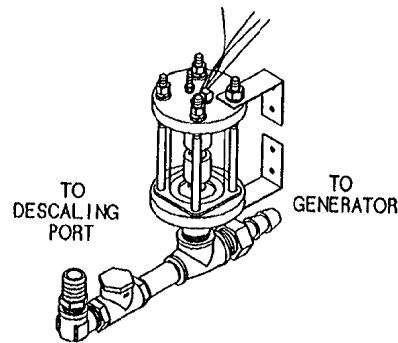

LET.	REVISIONS	DATE	BY
A	SEE E.O. #C-2631	08-02-94	PJD

ITEM	QTY.	PART NO.	DESCRIPTION
15	A/R	00934	SEALANT, RECTORSEAL
14	1	106428	PORT ASSEMBLY, DESCALER
13	1	1058451200	HOSE, NORPRENE, 1/2 ID X 3/4 OD X 12 LG
12	2	105848	CLAMP, PLASTIC, 3/4" OD HOSE
11	1	1060931100	HOSE, SILICONE, 3/4 ID X 1 OD X 11" LG
10	2	105847	CLAMP, PLASTIC, 1-1/8" HOSE
9	2	08240	FITTING, 3/4 H X 3/4 MPT
8	1	20208	TEE, 3/4 X 1/2 X 3/4, BRASS
7	1	14331	NIPPLE, 1/2" X 2-1/2", BRASS
6	1	108156	CHECK VALVE, 1/2" SWING W/ RUBBER SEAT
5	1	05253	ELBOW, STREET, 90° X 1/2", BRASS
4	1	08237	FITTING, 1/2 X 1/2 MPT, BRASS
3	1	14431	NIPPLE, 3/4" X 2", BRASS
2	2	106676	BRACKET, TOP/BOT. FLOAT SUPPORT
1	1	105877	FLOAT, ASSEMBLY, STEAMCRAFT

SEE NOTE 2

THIS DESIGN DESCRIBES A PROPRIETARY ITEM AND IS THE PROPERTY OF CLEVELAND RANGE. THIS DRAWING IS NOT TO BE COPIED OR USED WITHOUT THE APPROVAL OF CLEVELAND RANGE.

TOLERANCES (EXCEPT AS NOTED)			
DECIMAL	SCALE	DRAWN BY	APPROVED BY
± .030	1/4"	DUTCHMAN	
ANGULAR	TITLE		
± 1°	FLOAT AND DESCALER ASSEMBLY STEAMCRAFT 5.1, ELECTRIC		
CK	DATE	DRAWING NO.	REV.
	04-15-93	B - 106467	A

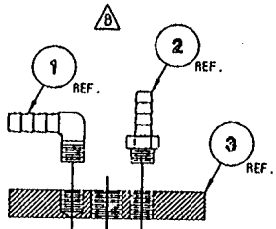

DETAIL A-A
SCALE: 1/2=1

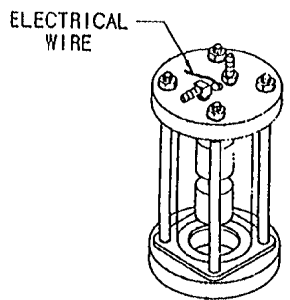

ASSEMBLED VIEW
SCALE: 1/4=1

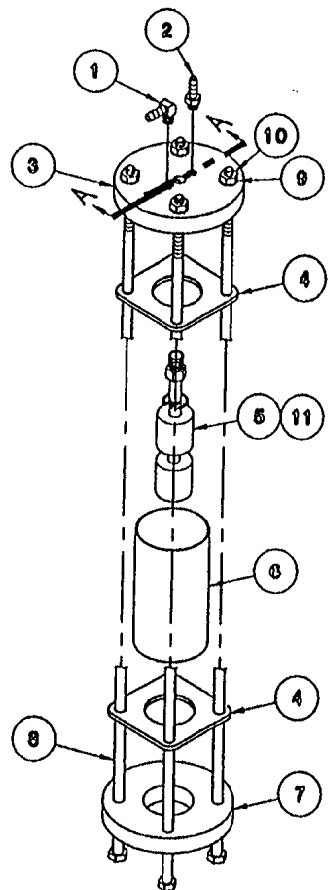

EXPLODED ASSEMBLY
SCALE: 1/4=1

THIS DESIGN DESCRIBES A PROPRIETARY ITEM AND IS THE PROPERTY OF CLEVELAND RANGE. THIS DRAWING IS NOT TO BE COPIED OR USED WITHOUT THE APPROVAL OF CLEVELAND RANGE.

REFERENCE:
260AHM 5 OF 5

LET.	REVISIONS	DATE	BY
A	CORRECTED P/N 105787	7-30-92	SM
B	ROTATED 90° P/NS 105787 & 104380 PER EO #C-2304	10-10-92	PD
C	THIS ASSEMBLY REPLACES P/N 104091 ON SC 3.1, 5.1 ELECT. & SC 10 ELECT. PER EO #C-2277 R3	02-02-93	PD

ITEM	QTY.	PART NO.	DESCRIPTION
11	A/R	00934	SEALANT, RECTORSAL
10	4	14618	NUT, HEX HEAD, 1/4-20, S/S
9	4	23105	WASHER, SPLIT LOCK, 1/4, S/S
8	4	104278	SCREW, HEX HEAD, 1/4-20 x 5.5, S/S
7	1	104040	CAP, FLOAT BOTTOM
6	1	1040190388	TUBE, POLYSULFONE, 2 x .125 x 3.875
5	1	103728	SWITCH ASSEMBLY, FLOAT
4	2	104041	GASKET, FLOAT ASSEMBLY
3	1	104039	TOP, FLOAT, STEAMCRAFT
2	1	104380	FITTING, HOSE BARB, 1/4 H x 1/8 MPT
1	1	105787	FITTING, HOSE BARB, 90°, 1/4 H x 1/8 MPT

TOLERANCES (EXCEPT AS NOTED)		CLEVELAND RANGE INC. 1333 East 179th St. Cleveland, Ohio 44110-2574	
DECIMAL ± N/A	SCALE AS SHOWN	DRAWN BY S. MILEWSKI	APPROVED BY
ANGULAR ± N/A	TITLE △ FLOAT ASSEMBLY, STEAMCRAFT 10 ELECTRIC, 3.1 AND 5.1		
CK	DATE 05-28-92	DRAWING NO. B - 105877	REV. C

107241 Water Level Board

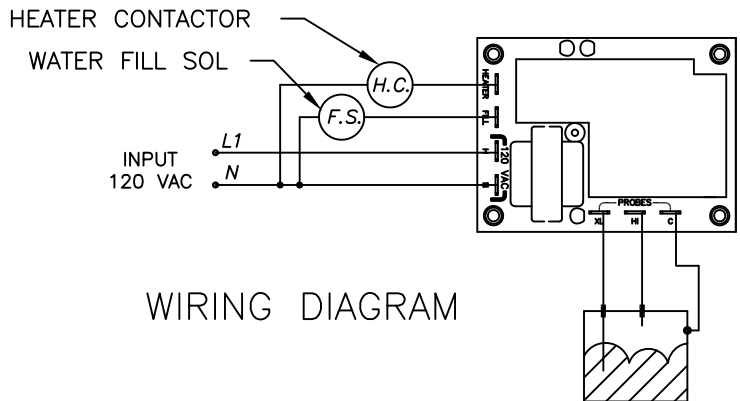
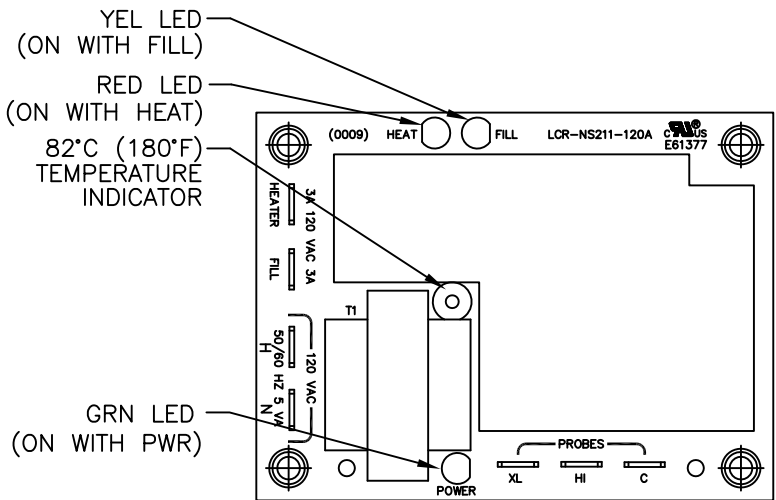

GENERAL DESCRIPTION

THIS SOLID STATE CONTROLLER SERVES AS A DUAL LEVEL WATER SENSING DEVICE. IT'S FUNCTIONS ARE TO:

1. MONITOR AND MAINTAIN A PRESET OPERATING WATER LEVEL WITHIN A STEAM GENERATOR VESSEL, AND
2. MONITOR THE SAFE LOW WATER LIMIT FOR HEATER OPERATION AND PROVIDE HEATER LOCK-OUT FOR UNSAFE OPERATION.

EACH FUNCTION WILL BE CONTROLLED BY RESISTANCE SENSING BETWEEN THE PROBES ("HI" & "LOW" TERMINALS) AND A GROUNDED COMMON ("C" TERMINAL).

LOW PROBE OPERATION

WHEN WATER CONTACTS PROBE, RESISTANCE BETWEEN "LOW" PROBE AND COMMON "C" WILL BE BELOW SET POINT (50 K OHM) AND OUTPUT RELAY WILL BE ACTIVATED IMMEDIATELY TO SUPPLY 120 VAC FROM L1 TO HTR TERMINAL. WHEN CONTACT BETWEEN WATER AND PROBE IS BROKEN (RESISTANCE GREATER THAN 50 K OHM) THE RELAY WILL BE DEACTIVATED WITHIN 0-2 SECONDS.

HI PROBE OPERATION

AS WATER MAKES CONTACT WITH PROBE, RESISTANCE BETWEEN "HI" AND COMMON "C" WILL BE BELOW SET POINT (50 K OHM) AND OUTPUT RELAY IS DEACTIVATED IMMEDIATELY. WHEN WATER BREAKS CONTACT WITH "HI" PROBE DELAY TIMING STARTS. TIMING IS NOT ACCUMULATIVE AND DELAY TIMER WILL BE RESET TO ZERO ANY TIME RESISTANCE BETWEEN "HI" PROBE AND COMMON "C" GOES BELOW SET POINT (50 K OHM). WHEN RESISTANCE BETWEEN HI PROBE AND COMMON "C" REMAINS ABOVE SET POINT FOR MORE THAN 5 SEC. (-2,+0 SEC.) THE OUTPUT RELAY ACTIVATED TO PROVIDE 120 VAC FROM L1 TO WF TERMINAL.

107239 Water Level Probe Assembly

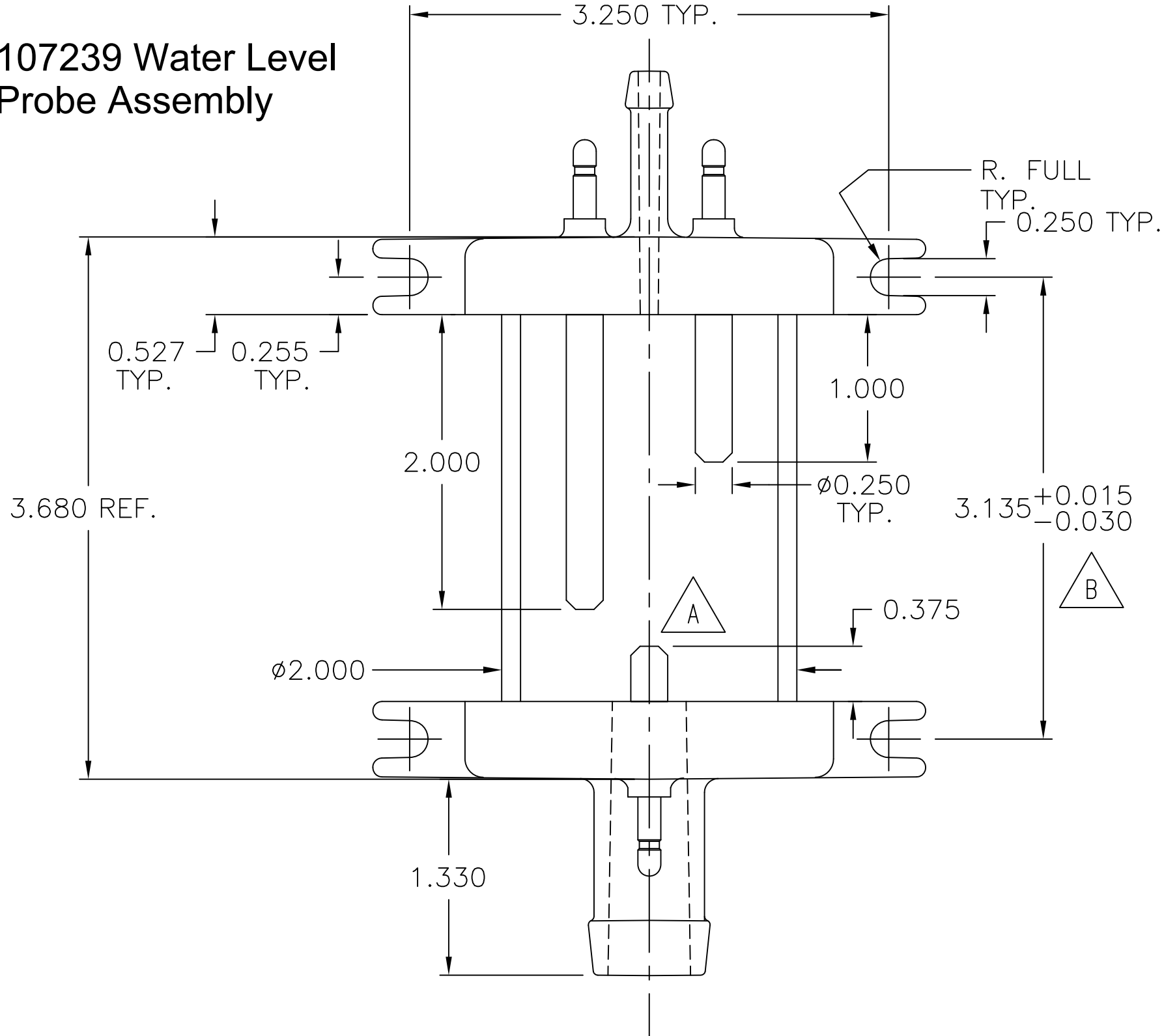

108727

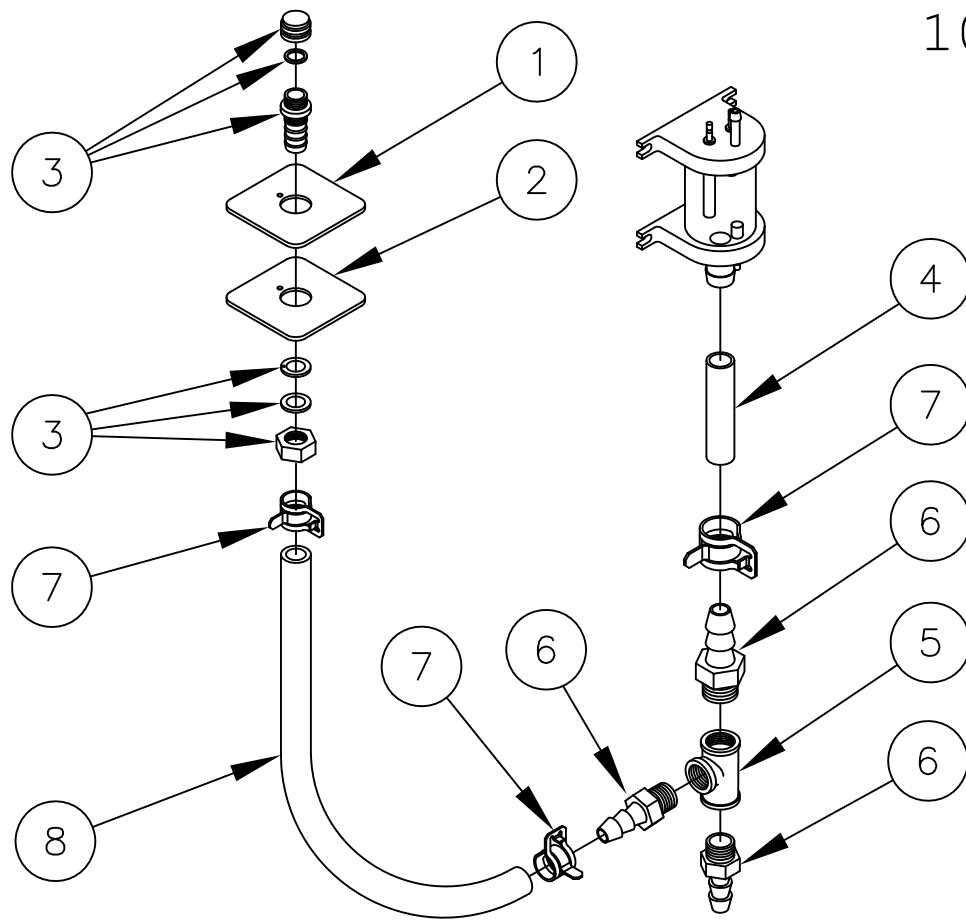

8	1	085112700	HOSE, WHITE, EPDM, 3/4 ID X 27.000 LG
7	2	107312	CLAMP, HOSE METAL TENSION, 1.125 OD HOSE
6	2	06240	FITTING, HOSE BARB, 3/4 X 3/4
5	1	20206	TEE, 3/4 BRASS
4	1	085110600	HOSE, WHITE, EPDM, 3/4 ID X 6.000
3	1	109641	PORT ASSEMBLY, DESCALER
2	1	108724	PLATE, DESCALER PORT CVRSN
1	1	108723	GASKET, DESCALER PORT CVRSN

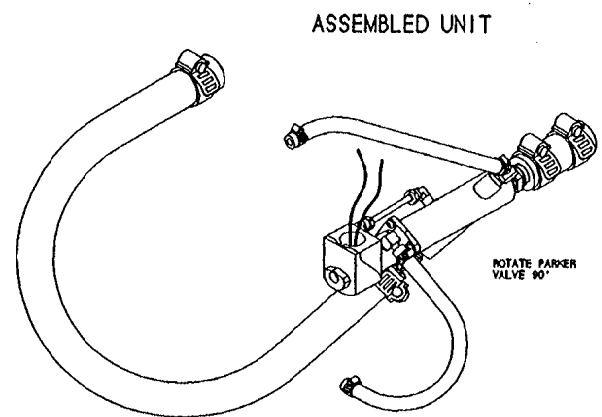
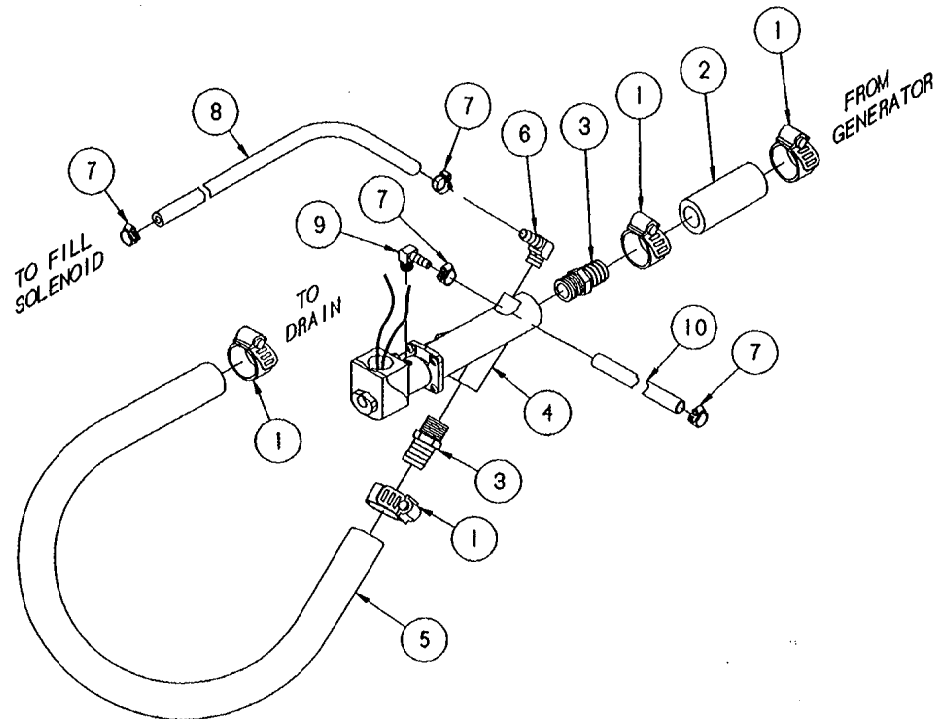

ITEM	QTY.	PART NO.	DESCRIPTION
10	1	1058500800	HOSE, NT-80, 1/4 X 1/2 X 8" LG.
9	1	105787	FITTING, HOSE 1/4 H X 1/8 MPT, 90°
8	1	1058500900	HOSE, NT-80, 1/4 X 1/2 X 9" LG.
7	4	108219	CLAMP, METAL, WORM DRIVE
6	1	105786	FITTING, HOSE 1/4 H X 1/4 MPT, 90°
5	1	085051400	HOSE, DARIPREEN 3/4" ID X 14" LG.
4	1	22244	VALVE, DRAIN, PARKER
3	2	08240	FITTING, HOSE 3/4 H X 3/4 NPT, STR
2	1	085050300	HOSE, DARIPREEN 3/4" ID X 3" LG.
1	4	03267	CLAMP, METAL, WORM DRIVE

TOLERANCES (EXCEPT AS NOTED)		CLEVELAND RANGE INC. 1333 East 179th St. Cleveland, Ohio 44110-2574	
DECIMAL ± N/A	SCALE 3/8=1	DRAWN BY DUTCHMAN	APPROVED BY
ANGULAR ± N/A	TITLE VALVE ASSEMBLY, DRAIN STEAMCRAFT 5.1, GAS		
CK	DATE 05-12-93	DRAWING NO. C - 106524	REV. -

THIS DESIGN DESCRIBES A PROPRIETARY ITEM AND IS THE PROPERTY OF CLEVELAND RANGE. THIS DRAWING IS NOT TO BE COPIED OR USED WITHOUT THE APPROVAL OF CLEVELAND RANGE.

LET.	REVISIONS	DATE	BY
A	ADDED NOTE FOR ASSEMBLY.	04/13/95	NT

NOTE: 1) Rotate solenoid valve 45° clockwise for left hinging units. Rotate solenoid valve 45° counter-clockwise for right hinging units.

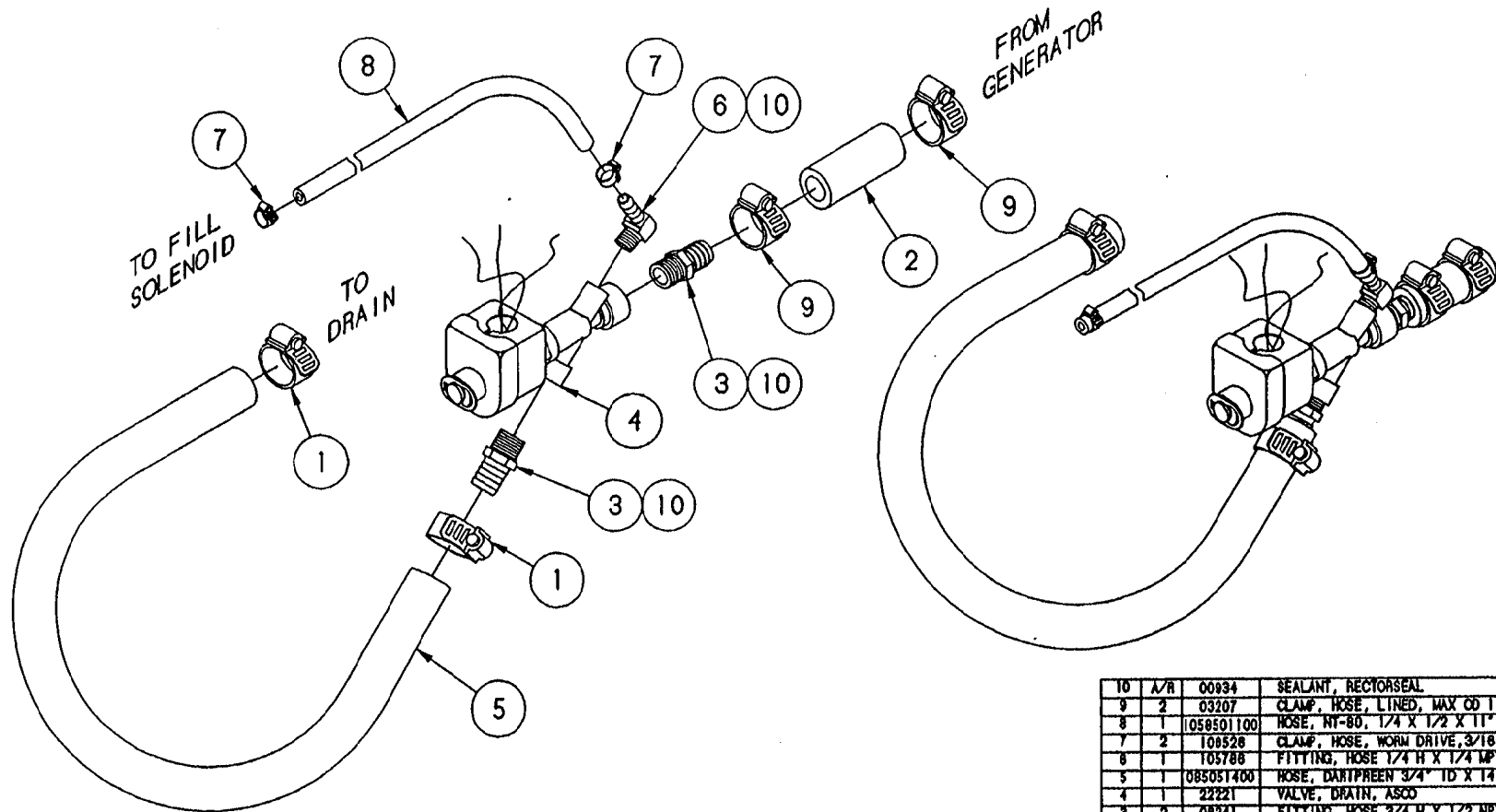

ITEM	QTY.	PART NO.	DESCRIPTION
10	A/R	00934	SEALANT, RECTORSAL
9	2	03207	CLAMP, HOSE, LINED, MAX OD 1.125"
8	1	1058501100	HOSE, RT-80, 1/4 X 1/2 X 11" LG.
7	2	106528	CLAMP, HOSE, WORM DRIVE, 3/18-5/18
6	1	105788	FITTING, HOSE 1/4 H X 1/4 MPT, 90°
5	1	085051400	HOSE, DARTGREEN 3/4" ID X 14" LG.
4	1	22221	VALVE, DRAIN, ASCO
3	2	08241	FITTING, HOSE 3/4 H X 1/2 NPT, STR
2	1	085110300	HOSE, SILGRADE, 3/4" ID X 3' LG.
1	2	03204	CLAMP, HOSE, WORM DRIVE, 3/4"

TOLERANCES (EXCEPT AS NOTED)			
DECIMAL	SCALE	DRAWN BY	APPROVED BY
± N/A	1/2" ± 1"	DUTCHMAN	
ANGULAR	TITLE	CLEVELAND RANGE INC. 1833 East 178th St. Cleveland, Ohio 44110-2574	
± N/A		VALVE ASSEMBLY, DRAIN STEAMCRAFT 3.1 AND 5.1	
CK	DATE	DRAWING NO.	REV.
	02-12-93	C - 106384	A

THIS DESIGN DESCRIBES A PROPRIETARY ITEM AND IS THE PROPERTY OF CLEVELAND RANGE. THIS DRAWING IS NOT TO BE COPIED OR USED WITHOUT THE APPROVAL OF CLEVELAND RANGE.

NOTE:

1. USE THREAD JOINT COMPOUND AS REQUIRED TO SEAL.

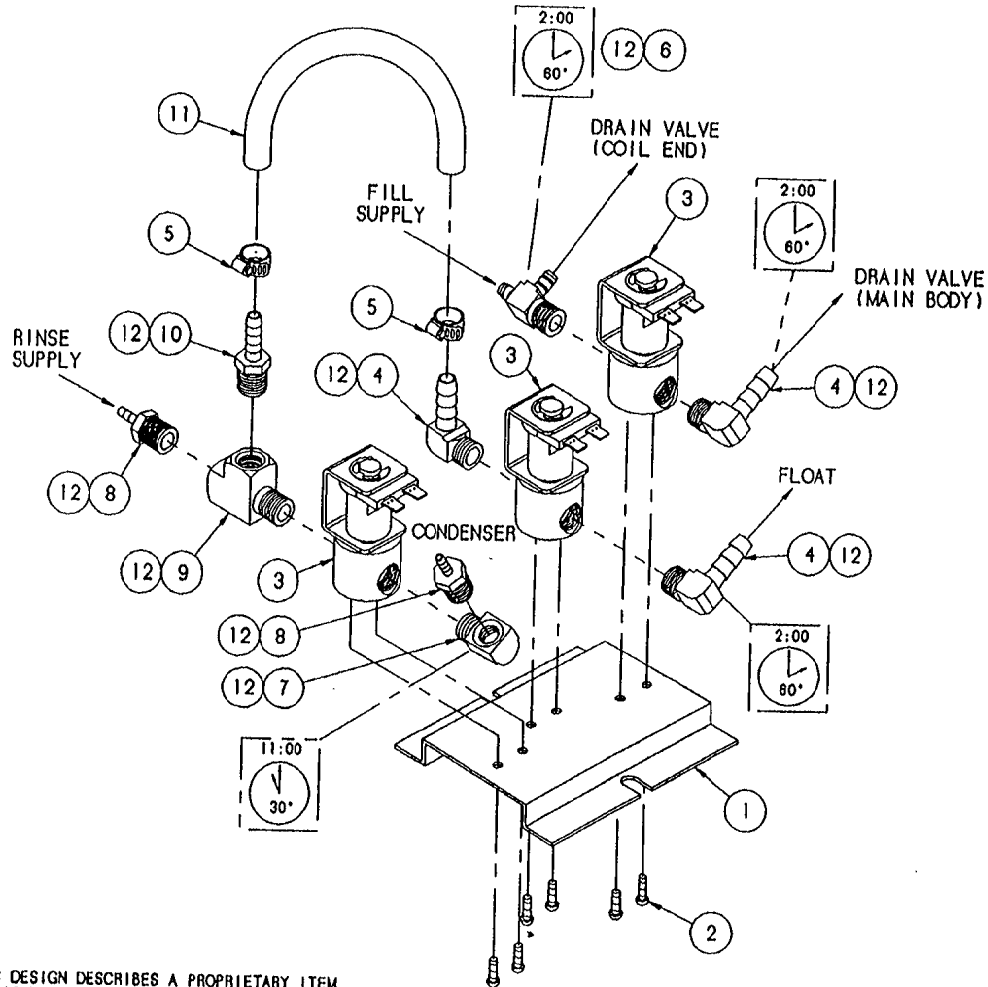

LET.	REVISIONS	DATE	BY
A	106522 REPLACED 104087, 106526 REPLACED 106219, ADDED NEW PARTS & NEW TUBING LAYOUT PER E.O. #C-2492	08-23-93	PJD

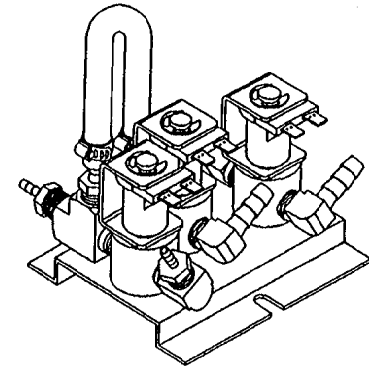

SEE NOTE 1

ITEM	QTY.	PART NO.	DESCRIPTION
12	A/R	00934	SEALANT, RECTORSEAL
△ 11	1	1058500600	TUBING, NT-80, 1/4" X 6'
△ 10	1	104381	FITTING, HOSE, 1/4 H X 1/4 MPT, STR.
△ 9	1	106663	FITTING, MALE RUN, 1/4 MPT X 1/4 FPT
△ 8	2	106661	FITTING, HOSE, 1/8 H X 1/4 MPT, STR.
△ 7	1	05235	ELBOW, STREET 1/4 X 90°, BRASS
△ 6	1	106588	FITTING, TEE, 1/4 H X 1/4 MPT X 1/4 H
△ 5	2	106526	CLAMP, HOSE, 3/8 X 5/8 X 5/16 W
△ 4	3	105786	FITTING, HOSE, 1/4 H X 1/4 MPT, 90°
3	3	22218	SOLENOID VALVE
2	6	101872	SCREW, #8-32 X 1/4 THD. CUT
1	1	104284	BRACKET, MOUNTING
TOLERANCES (EXCEPT AS NOTED)			CLEVELAND RANGE INC. 1333 East 179th St. Cleveland, Ohio 44110-2574
DECIMAL	SCALE	DRAWN BY	
± N/A	1/2 = 1	ARB	
ANGULAR	TITLE		
± 1°	VALVE ASSY, WATER INLET SC 3.1 & 5.1, H.L.		
CK	DATE	DRAWING NO.	REV.
	08-24-93	B - 106522	A

THIS DESIGN DESCRIBES A PROPRIETARY ITEM AND IS THE PROPERTY OF CLEVELAND RANGE. THIS DRAWING IS NOT TO BE COPIED OR USED WITHOUT THE APPROVAL OF CLEVELAND RANGE.

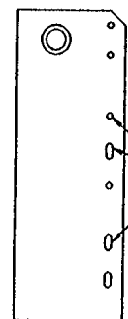
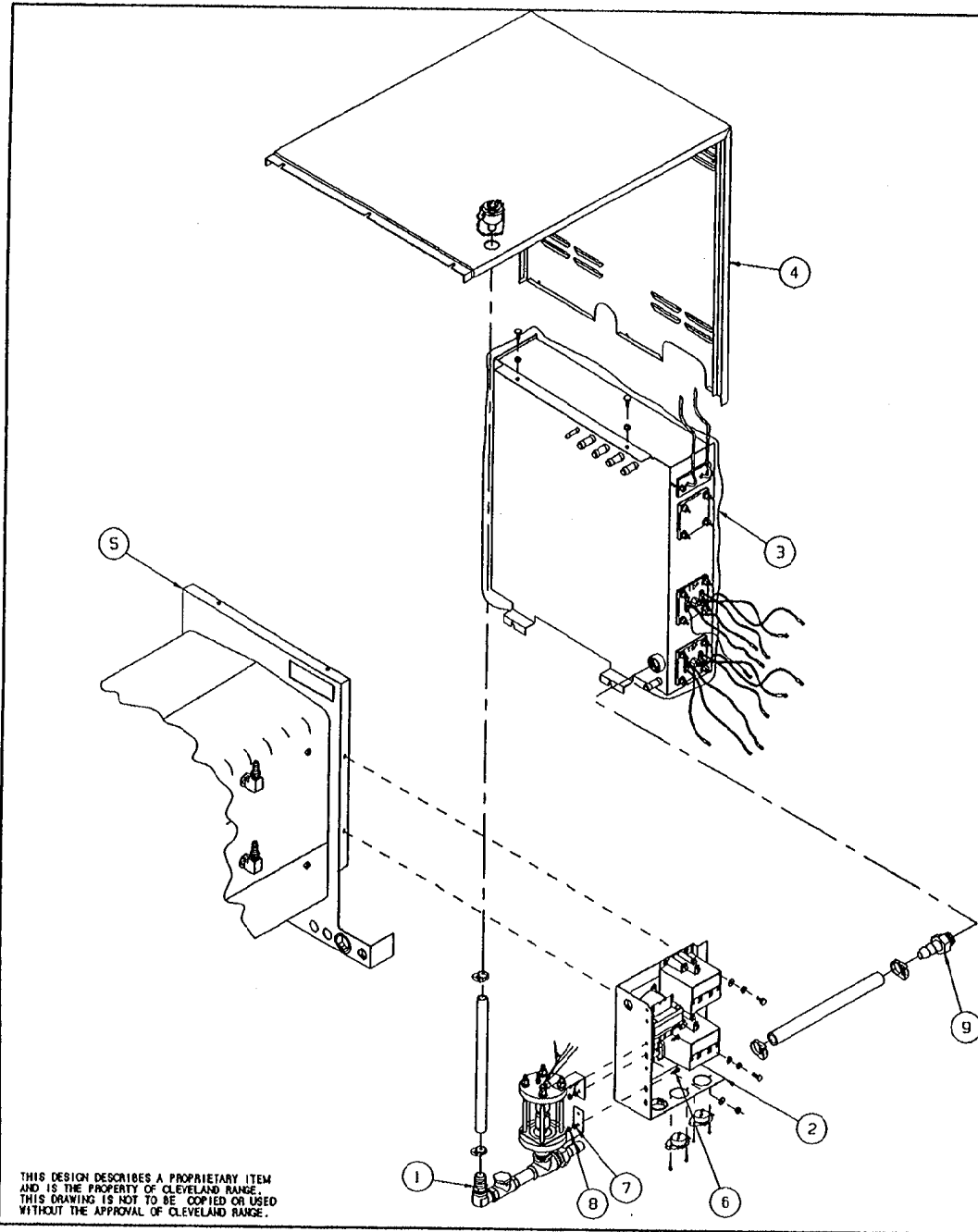

HOLES AND SLOTS USED ON COMPONENT BOX TO MOUNT FLOAT/DESCALER ASSY.

THIS DESIGN DESCRIBES A PROPRIETARY ITEM AND IS THE PROPERTY OF CLEVELAND RANGE. THIS DRAWING IS NOT TO BE COPIED OR USED WITHOUT THE APPROVAL OF CLEVELAND RANGE.

ITEM	QTY.	PART NO.	DESCRIPTION
9	1	06210	FITTING, 3/4 H X 3/4 MPT
8	3	14892	NUT, HEX LOCK ELASTIC 10-24
7	3	101855	WASHER, FLAT #10, S/S
8	3	19287	SCREW, PAN HEAD 10-24 X 1/2, S/S
5	-	1041971	CAVITY, WELD ASSY., H.L.
4	-	104037	SHEETING, TOP/BACK
3	-	104194	GENERATOR ASSY.
2	1	104200	COMPONENT PANEL ASSY.
1	1	106467	FLOAT AND DESCALER ASSY.

TOLERANCES (UNLESS AS NOTED)		CLEVELAND RANGE INC. 1333 East 179th St., Cleveland, Ohio 44110-2574	
DECIMAL ± N/A	SCALE 3/16=1	DRAWN BY DUTCHMAN	APPROVED BY
ANGULAR ± N/A	TITLE INSTALLATION OF FLOAT/DESCALER TO COMPONENT BOX ON ULTRA 5 ELECTRIC		
CK	DATE 07-14-94	DRAWING NO. C - 260AKX	REV. -

LET.	REVISIONS	DATE	BY
A	SEE E.O. 12812	12-18-94	PJD

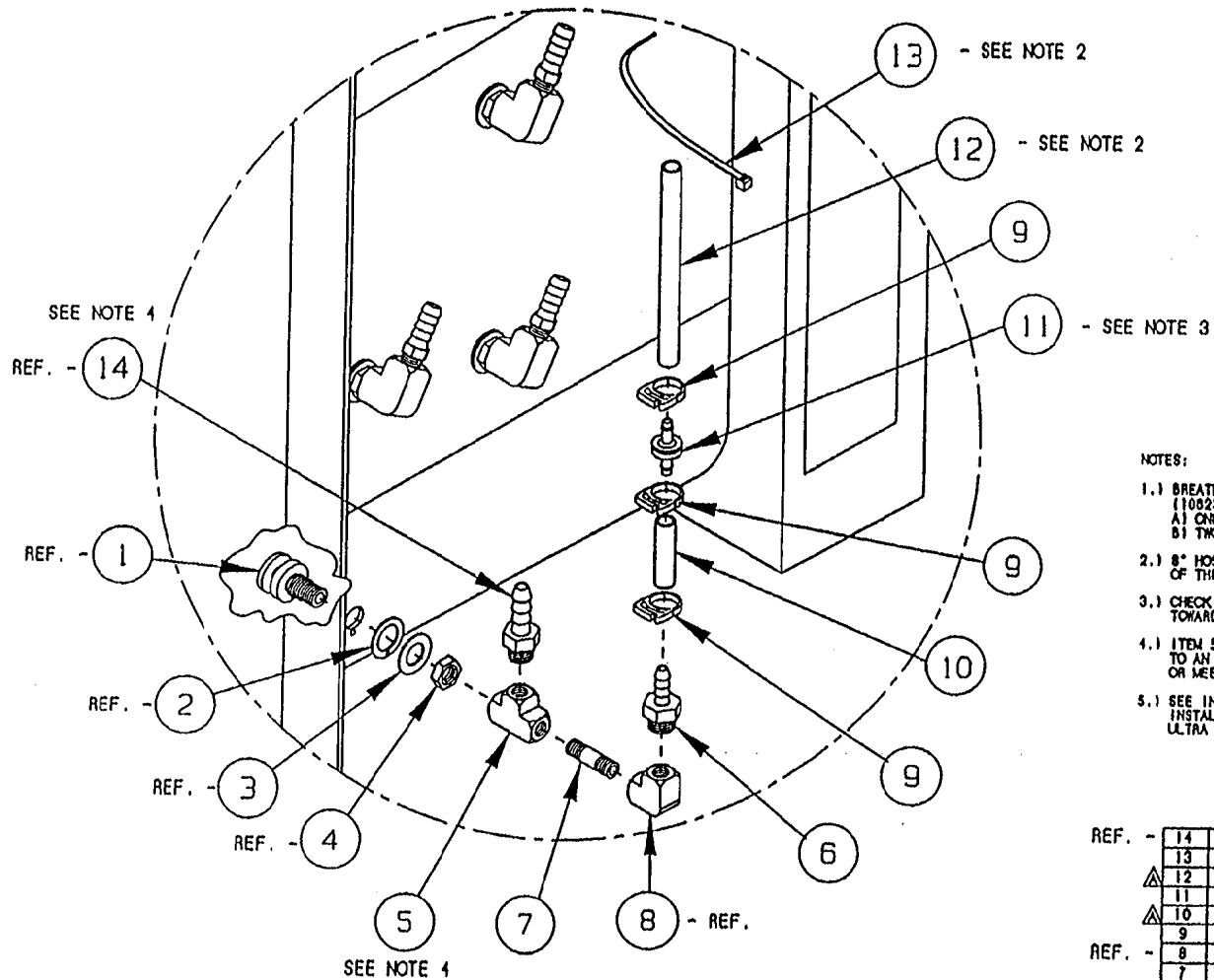

NOTES:

- 1.) BREATHER ASSY. (1070591) TO REPLACE ONE SPRAY NOZZLE ASSY. (1082301) ONE PLACE PER CAVITY ON ALL STEAMCRAFT ULTRA UNITS A) ONE COMPARTMENT UNITS = ONE BREATHER ASSY. B) TWO COMPARTMENT UNITS = TWO BREATHER ASSY.
- 2.) 8" HOSE IS TO BE SECURED WITH NYLON CABLE TO THE HOSE OF THE SPRAY NOZZLE ASSY. DIRECTLY ABOVE THE NEW ASSY.
- 3.) CHECK VALVE - SIDE WHICH READS "VAC" MUST FACE DOWN TOWARD HOSE BARB
- 4.) ITEM 5 (P/N 20199) AND ITEM 6 (P/N 104081) TO BE ROTATED TO AN ANGLE THAT WILL MATCH THE OTHER SPRAY NOZZLES OR MEET A MATING HOSE FITTING
- 5.) SEE INSTRUCTIONAL DRAWINGS 280AL81-280AL87 FOR INSTALLATION OF THIS ASSEMBLY INTO THE STEAMCRAFT ULTRA UNITS.

REF.	QTY.	PART NO.	DESCRIPTION
REF. - 14	-	104048	FITTING, 1/2 HOSE X 1/4 MPT
13	1	20451	TIE, NYLON CABLE
△ 12	1	1043790500	HOSE, SILICONE 1/4 ID X 1/2 OD X 5'
11	1	107032	CHECK VALVE, PLASTIC DIAPHRAGM
△ 10	1	1043790300	HOSE, SILICONE 1/4 ID X 1/2 OD X 3'
9	3	104383	CLAMP, HOSE, NYLON
REF. - 8	-	05236	ELBOW, 1/4 X 90°, BRASS
7	1	14411	NIPPLE, 1/4 X 1.5", BRASS
6	1	104381	FITTING, 1/4 HOSE X 1/4 MPT
5	1	20199	TEE, 1/4 BRASS
4	-	104081	NUT, HEX JAW 5/8-18 BRASS
3	-	104232	WASHER, FLAT S/S
2	-	104082	GASKET, STEAM INJECTOR
1	-	104009	FITTING ASSY., STEAM SUPPLY
			DESCRIPTION

TOLERANCES (UNLESS OTHERWISE SPECIFIED)			
CLEVELAND RANGE INC. 1333 East 179th St. Cleveland, Ohio 44110-2571			
DECIMAL ± N/A	SCALE 3/16±1	DRAWN BY DUTCHMAN	APPROVED BY
ANGULAR ± N/A	TITLE BREATHER/SPRAY NOZZLE ASSY. (1/2" HOSE) STEAMCRAFT ULTRA 3, 5		
CK	DATE 09-15-94	DRAWING NO. C - 1070001	REV. A

THIS DESIGN DESCRIBES A PROPRIETARY ITEM AND IS THE PROPERTY OF CLEVELAND RANGE. THIS DESIGN IS NOT TO BE COPIED OR USED WITHOUT THE APPROVAL OF CLEVELAND RANGE.

NOTES :

1. SEE WIRING DIAGRAM 104247 OR 104248 FOR CONNECTION LOCATION .

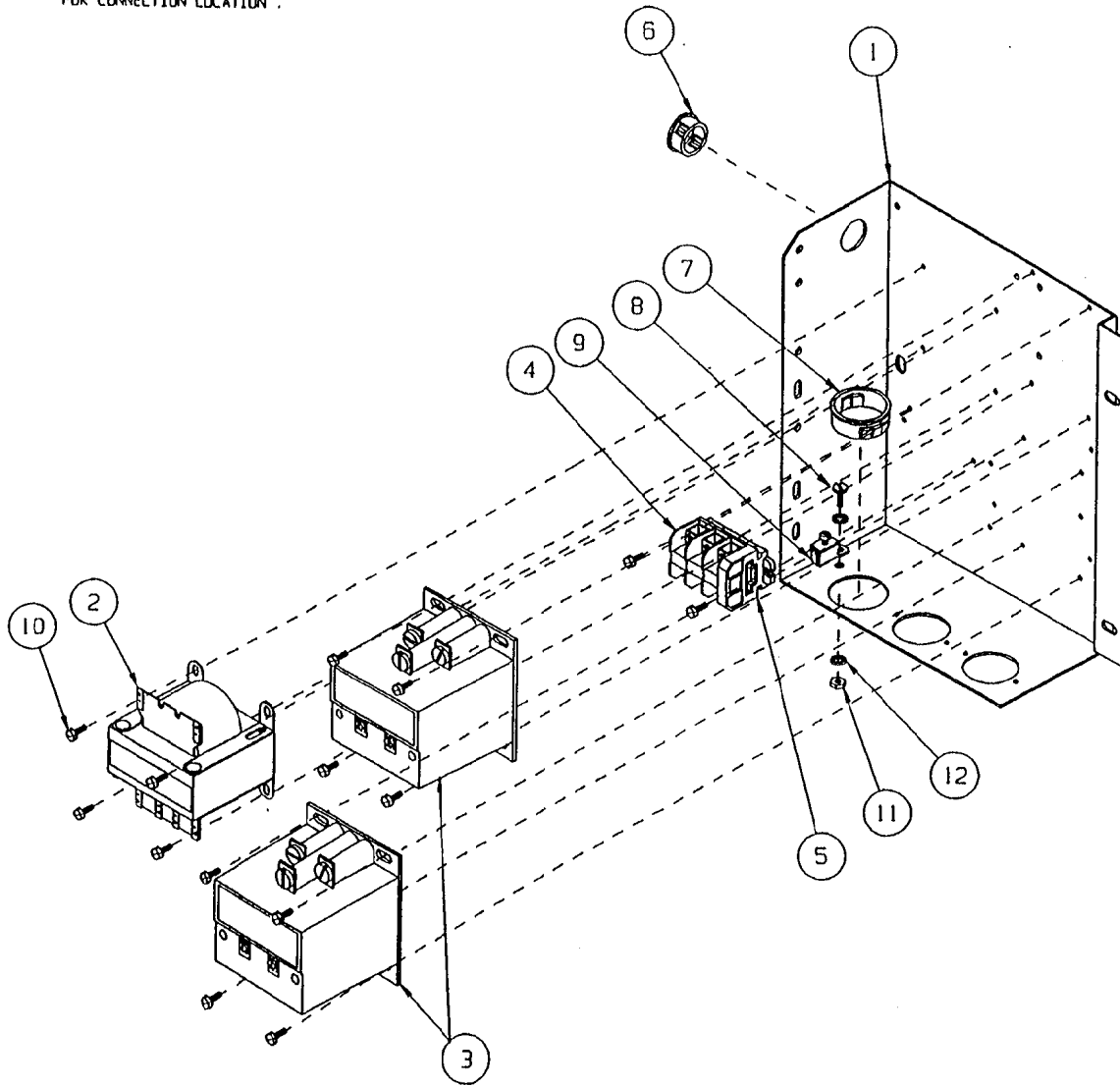

LET.	REVISIONS	DATE	BY
A	101541 WAS DTY. OF 101540 WAS DTY. OF 3. 104223 WAS DTY. OF 14. ADDED 104225 & 1042251 PER E.O. # C-1876 R2	03-28-91	P/M
B	OMITTED 104223 & 101336, ADDED 106127, 15010 AND 18358, 103936 WAS 104092 PER E.O AC-2502	09-14-93	P/D
C	P/N 106754 WAS 106127, REMOVED S/N TAG PER EQ #C2548	01/14/93	1FA

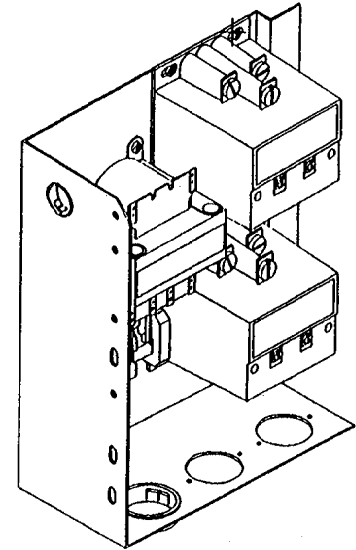

SEE NOTE 1

ITEM	QTY.	PART NO.	DESCRIPTION
16	2	1042251	WIRE ASSEMBLY
15	3	104225	WIRE ASSEMBLY
12	2	23114	WASHER, INTERNAL TOOTH, #10 S/S
11	1	14659	NUT, HEX 10-24, S/S
10	14	106754	SCREW, HEX/ WASHER HEAD #6 X 3/8
9	1	20304	GROUND LUG, BURNDY #KPABC
8	1	101231	SCREW, 10-24 X 1/2 TRUSS HEAD, S/S
7	1	102581	BUSHING, HEYCO, SNAP-IN
6	1	02600	BUSHING, HEYCO SB-875-11, INSULATOR
5	1	101540	END SEGMENT, TERMINAL BLOCK, 85 AMP
4	3	101541	TERMINAL SEGMENT, CLAMP TYPE, 85 AMP
3	2	103905	CONTACTOR 30 AMP, MERCURY
2	1	20533	TRANSFORMER 75 VA, 240/480 PRIMARY, 120 SECONDARY 1075
1	1	103936	PANEL, COMPONENT WELD ASSY.

TOLERANCES
(EXCEPT AS NOTED)

CLEVELAND RANGE INC.
1333 East 179th St. Cleveland, Ohio 44110-2574

DECIMAL ± N/A SCALE 1/2 DRAWN BY R. RIOS APPROVED BY J.B.

ANGULAR ± N/A TITLE COMPONENT PANEL, H.L. STEAMCRAFT 5.1

DATE 08-30-90 DRAWING NO. C - 104200 REV C

THIS DESIGN DESCRIBES A PROPRIETARY ITEM AND IS THE PROPERTY OF CLEVELAND RANGE. THIS DRAWING IS NOT TO BE COPIED OR USED WITHOUT THE APPROVAL OF CLEVELAND RANGE.

LET.	REVISIONS	DATE	BY
------	-----------	------	----

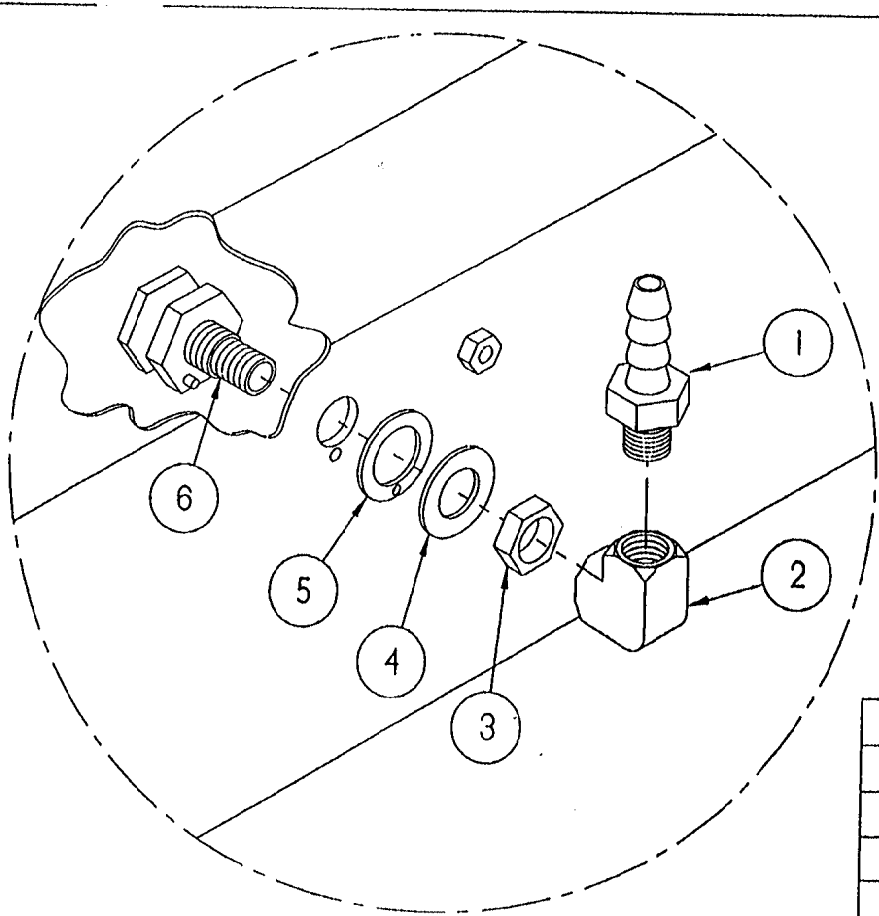

TYPICAL APPLICATION

ITEM	QTY.	PART NO.	DESCRIPTION
6	1	104009	FITTING, ASSY, STEAM SUPPLY
5	1	104082	GASKET, STEAM INJECTOR
4	1	104232	WASHER, FLAT S/S
3	1	104081	NUT, JAM 5/8-18, BRASS
2	1	05236	ELBOW, 1/4" X 90°, BRASS
1	1	104048	FITTING, HOSE 1/2 H X 1/4 MPT

TOLERANCES (EXCEPT AS NOTED)		CLEVELAND RANGE INC. 1333 East 179th St. Cleveland, Ohio 44110-2574	
DECIMAL ± .030	SCALE 1/2"		
ANGULAR ± 1°	TITLE SPRAY NOZZLE ASSEMBLY STEAMCRAFT 3.1, 5.1 AND 10		
CHK	DATE 02-12-93	DRAWING NO. A - 1062301	REV. 1

THIS DESIGN DESCRIBES A PROPRIETARY ITEM AND IS THE PROPERTY OF CLEVELAND RANGE. THIS DRAWING IS NOT TO BE COPIED OR USED WITHOUT THE APPROVAL OF CLEVELAND RANGE.

LET	REVISIONS	DATE	BY
A	ITEM #12 WAS 08193, 10 WAS FROM ITEM #8, E.O. 1794	10-1-90	R.R.
B	REMOVED P/N'S 03524, 03525, 104223 & 101855 - REVISED P/N'S 104195 & 104091 - E.O. 1876 RI COST REDUCTION	02-12-91	P.D.
C	ADDED STUDS ON GENERATOR, PICTORIAL ADDED HEATER & ELEMENT VARIATIONS AND P/N 103731 TO PART LIST E.O. 4C-2308	10-14-92	PC
D	P/N 104091 PICTORIAL REVISED PER E.O. 4C-2277	01-12-93	PJD
E	P/N 105877 WAS 104091 PER E.O. 4C-2277 R3	02-02-93	PJD
F	REMOVED FLOAT ASSEMBLY (P/N'S 105877, 14352, 05260 & 1040841 PER E.O. 4C-2631)	08-02-94	PJD

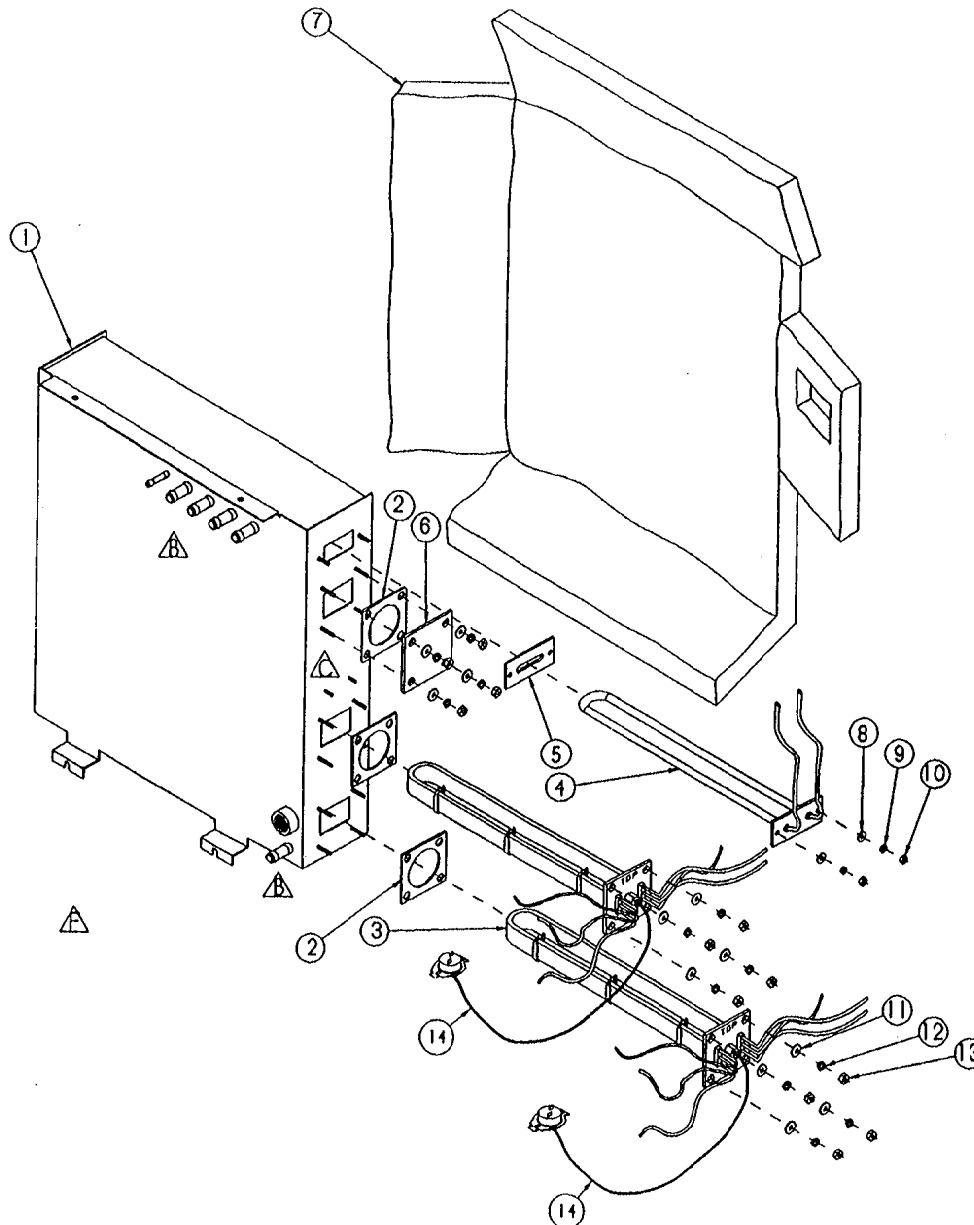

△	14	2	103731	CAPILLARY, HI LIMIT
	13	12	14818	NUT, HEX, 1/4-20 S/S
	12	12	23105	WASHER, LOCK, 1/4 S/S
	11	12	23118	WASHER, FLAT 1/4 X 5/8
	10	2	14859	NUT, HEX, 10-24 S/S
	9	2	23113	WASHER, LOCK, SPLIT RING, CAD PLATED, #10
	8	2	101855	WASHER, FLAT, #10 S/S
	7	1	104192	INSULATION, CUT, GENERATOR
	6	1	104614	PLATE, GENERATOR CLEAN-OUT
	5	1	104388	GASKET, DRYING ELEMENTS
			1043064	ELEMENT, IMMERSION, 300W, 415 V
			1043063	ELEMENT, IMMERSION, 300W, 380 V
△	4		1043062	ELEMENT, IMMERSION, 300W, 480 V
			1043061	ELEMENT, IMMERSION, 300W, 240 V
			104306	ELEMENT, IMMERSION, 300W, 208 V
			1038815	HEATER ASSY, 8 kw, 380 V
			1038814	HEATER ASSY, 8 kw, 480 V
△	3		1038812	HEATER ASSY, 8 kw, 415 V
			1038811	HEATER ASSY, 8 kw, 240 V
			103881	HEATER ASSY, 8 kw, 208 V
	2	3	07128	GASKET
△	1	1	104195	GENERATOR ASSY, WELD, SC S.1

NO.	QTY.	PART NO.	DESCRIPTION
TOLERANCES (EXCEPT AS NOTED)			
Cleveland Range Inc. 1333 East 179th St. Cleveland, OH 44110-2514			
DECIMAL : N/A	SCALE 1/4=1	DRAWN BY R. RIOS	APPROVED BY J. B.
ARELLAN J. N/A	TITLE GENERATOR ASSEMBLY, H.L. STEAMCRAFT ULTRA 5 & 10		
CK	DATE 9-04-90	DRAWING NO. C-104194	REV. F

THIS DESIGN DESCRIBES A PROPRIETARY ITEM AND IS THE PROPERTY OF CLEVELAND RANGE. THIS DRAWING IS NOT TO BE COPIED OR USED WITHOUT THE APPROVAL OF CLEVELAND RANGE.

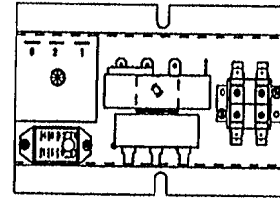
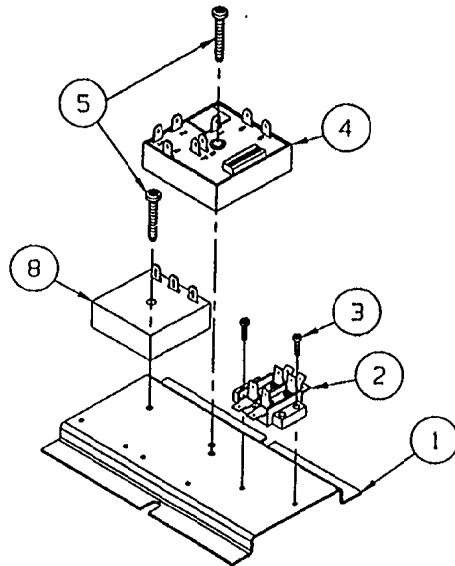
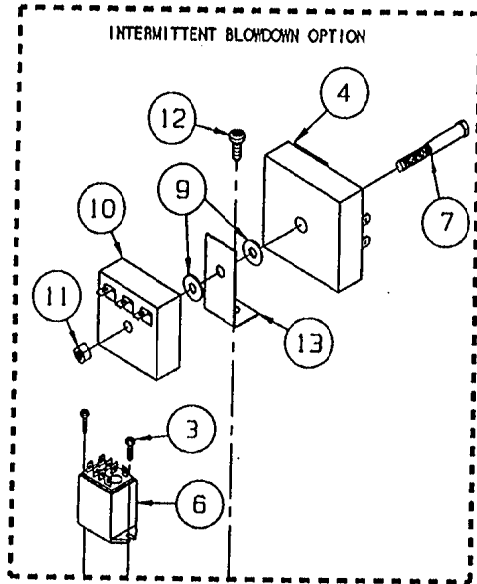

106433

INTERMITTENT BLOWDOWN (OPTIONAL)

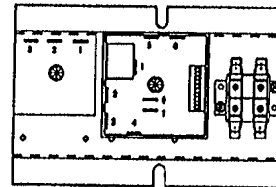

1064331

HEAT STANDBY (STANDARD)

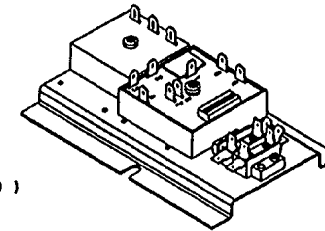
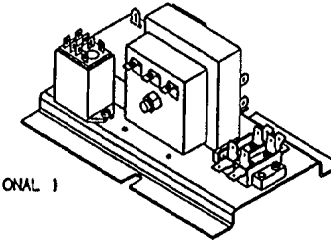

LET.	REVISIONS	DATE	BY
A	REVISED NOTES PER E.O. 1C-2	04-14-93	PJD
B	REDRAWN & REVISED PER ED1C-2400 R1	08-17-93	PJD
C	ADDED SC 5.1 GAS TIMER	08-02-93	PJD
D	P/N 106541 WAS 104718	11-04-93	DFA
E	ADDED CONFIGURATION FOR CLEAN LIGHT AND REMOVED SC 5.1 GAS FROM B.O.M. PER E.O. 1C-2812	09-15-94	PJD
F	ROTATED TIMERS ON ASSEMBLY 106433 PER E.O. 1C-2732	11-29-94	PJD

△	13	-	1	105955	BRACKET, DUAL TIMER MOUNTING
△	12	-	1	108123	SCREW, TORX/SLOT #10-32 X .500" LG.
△	11	-	1	14618	NUT, HEX 1/4-20, FULL FINISH
△	10	-	1	108541	TIMER, 1 MIN. ON 0.8 SEC. OFF
△	9	-	2	23118	WASHER, FLAT 1/4-20 S/S
△	8	1	1	108247	INTERVAL TIMER, 2 SEC. ON, 64 SEC. OFF
△	7	-	1	108118	BOLT, 1/4-20 X 2-1/4, ZINC PLATED
△	6	-	1	105966	RELAY, 120 V, DPDT
△	5	2	1	108124	SCREW, TORX/SLOT #10-32 X 1.00" LG.
△	4	1	1	108911	TIMER, CLEAN LIGHT (DIP SWITCHES)
△	3	2	4	108127	SCREW, TORX/SLOT #8-32 X .500" LG.
△	2	1	1	44168	TERMINAL, BLOCK ASM, 2 POLE
△	1	1	1	108308	BRACKET, OPTION PLATE
	ITEM	QTY.		PART NO.	DESCRIPTION

1064331 HEAT STANDBY	106433 INT. BLOWDOWN	TOLERANCES (EXCEPT AS NOTED)		CLEVELAND RANGE INC. 1333 East 179th St. Cleveland, Ohio 44110-2574	
		DECIMAL ± N/A	SCALE 1/2" = 1"	DRAWN BY DUTCHMAN	APPROVED BY
		TITLE HEAT STANDBY PLATE WITH INTERMITTENT BLOWDOWN OPTION STEAMCRAFT ULTRA 3 & 5 ELEC.			
		DATE 03-18-93	DRAWING NO. C - 106433/106	REV. F	

THIS DESIGN DESCRIBES A PROPRIETARY ITEM AND IS THE PROPERTY OF CLEVELAND RANGE. THIS DRAWING IS NOT TO BE COPIED OR USED WITHOUT THE APPROVAL OF CLEVELAND RANGE.

LET.	REVISIONS	DATE	BY
A	REVISED NOTES PER E.O. J1 R2	04-14-93	PJD
B	REDRAWN & REVISED PER EDC-2400 R1	08-17-93	PJD
C	ADDED SC 5.1 GAS TIMER	08-02-93	PJD
D	P/N 106541 VAS 104718	11-04-93	DFA

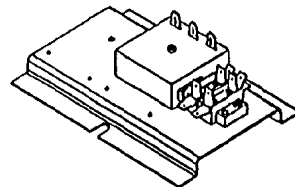
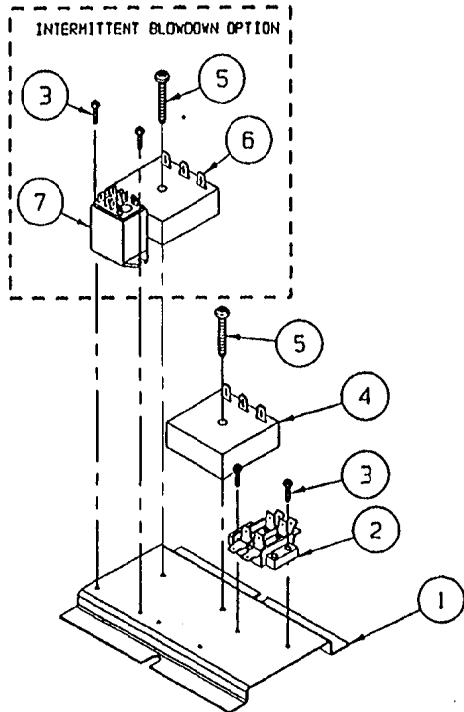

HEAT STANDBY (STANDARD)

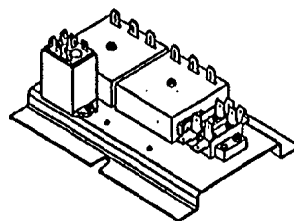

INTERMITTENT BLOWDOWN (OPTIONAL)

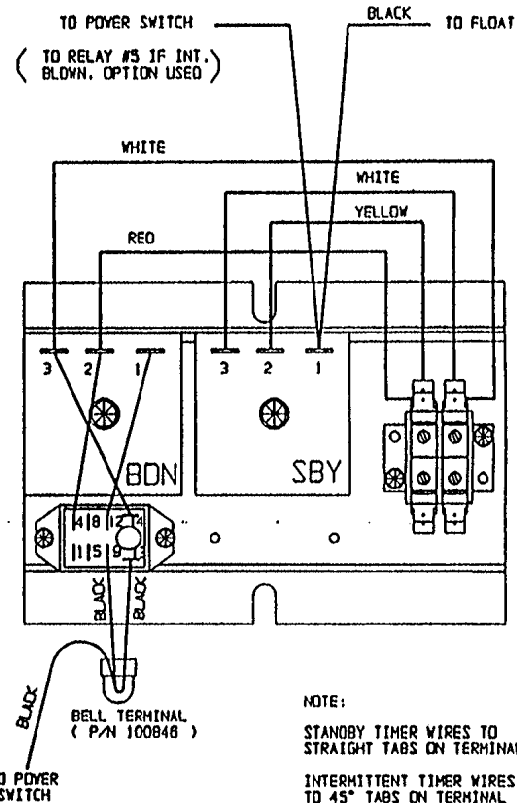

NOTE:
STANDBY TIMER WIRES TO STRAIGHT TABS ON TERMINAL
INTERMITTENT TIMER WIRES TO 45° TABS ON TERMINAL

7	1	1	-	105966	RELAY, 120 V, DPDT	
6	1	1	-	106541	TIMER, 1 MIN ON 0.8 SEC OFF	
5	2	2	1	106124	SCREW, TORX/SLOT 10-32 X 1.00"	
4	-	-	1	106580	TIMER, 20 SEC ON, 6 MIN. OFF	
4	1	1	-	106247	TIMER, 2 SEC ON, 64 SEC OFF	
3	4	4	2	106127	SCREW, TORX/SLOT 6-32 X 1/2"	
2	1	1	1	44168	TERMINAL, BLOCK ASM, 2 POLE	
1	1	1	1	106306	BRACKET, OPTION PLATE	
ITEM	QTY.	PART NO.	DESCRIPTION			

STEAMCRAFT 3.1	STEAMCRAFT 5.1	SC 5.1 GAS
----------------	----------------	------------

TOLERANCES (EXCEPT AS NOTED)			
DECIMAL & N/A	SCALE 1/2"=1"	DRAWN BY DUTCHMAN	APPROVED BY
ANGULAR & N/A	TITLE HEAT STANDBY PLATE WITH INTERMITTENT BLOWDOWN OPTION STEAMCRAFT 3.1 & 5.1		
CK	DATE 03-18-93	DRAWING NO. C - 106433	REV. 0

THIS DESIGN DESCRIBES A PROPRIETARY ITEM AND IS THE PROPERTY OF CLEVELAND RANGE. THIS DRAWING IS NOT TO BE COPIED OR USED WITHOUT THE APPROVAL OF CLEVELAND RANGE.

LET.	REVISIONS	DATE	BY
------	-----------	------	----

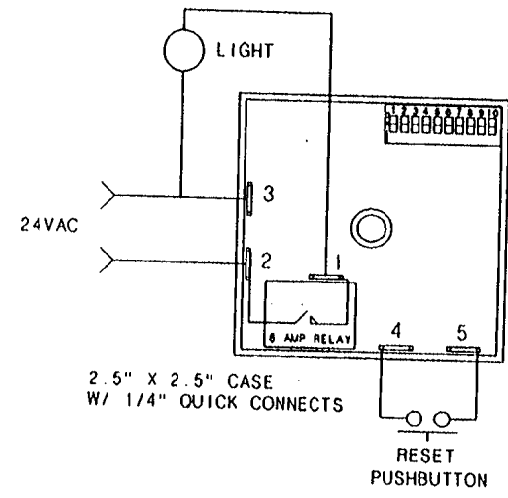

2.5" X 2.5" CASE
W/ 1/4" QUICK CONNECTS

SWITCH #	TIME AMOUNT
1 *	0.5 HR
2 *	1.0 HR
3 *	2.0 HR
4 *	4.0 HR
5 *	8.0 HR
6 *	16.0 HR
7 *	32.0 HR
8 *	64.0 HR
9 *	128.0 HR
10 *	256.0 HR

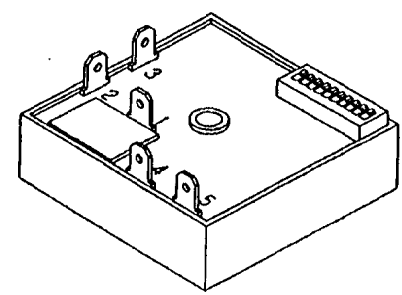

COMBINE SWITCHES FOR TIME DELAY IN HOURS
EXAMPLES:
37 HRS • SWITCH 7 • SWITCH 4 • SWITCH 2
250 HRS • SWITCH 9 • SWITCH 8 • SWITCH 7
• SWITCH 6 • SWITCH 5 • SWITCH 3

SOURCE:
AIROTRONICS
2747 RT. 20 E. BOX 326
CAZENOVIA, N.Y. 13035

TYPE: CR-2 TG CXB3511H5E2
INPUT: 24 VAC, 6 AMP
DELAY: 5-511, 5 HR. ON-DLY

OPERATION:
SELECT DELAY VIA DIP SWITCH. APPLY 24VAC TO THE TIMER.
AS THE SUPPLY VOLTAGE IS TURNED ON AND OFF TO THE TIMER
THE TIMER WILL KEEP TRACK OF THE ELAPSED TIME THE
SUPPLY VOLTAGE IS ON. ONCE THE TIMERS SUPPLY VOLTAGE HAS
BEEN ON LONGER THAN THE SELECTED DELAY THE RELAY WILL
TRANSFER. THIS IN TURN WILL TURN ON THE INDICATOR LIGHT.
ONCE THIS HAS HAPPENED THE RESET BUTTON WILL BECOME
ACTIVE AND ALLOW THE TIMER TO BE RESET.

THIS DESIGN DESCRIBES A PROPRIETARY ITEM
AND IS THE PROPERTY OF CLEVELAND RANGE.
THIS DRAWING IS NOT TO BE COPIED OR USED
WITHOUT THE APPROVAL OF CLEVELAND RANGE.

ITEM	QTY.	PART NO.	DESCRIPTION
TOLERANCES (EXCEPT AS NOTED)		CLEVELAND RANGE INC. 1333 East 179th St. Cleveland, Ohio 44110-2574	
DECIMAL ± .030	SCALE 1=1	DRAWN BY DUTCHMAN	APPROVED BY
ANGULAR ± 1°	TITLE TIMER, CLEAN LIGHT (DIP SWITCHES)		
CK	DATE 05-23-94	DRAWING NO. B - 106911	REV. -

LET.	REVISIONS	DATE	BY
A	WAS: HIGH LIMIT NOW: FLOAT PER E.O. 10-2381 R1	93-01-93	PJD
B	20351 BLACK WAS FROM FLOAT ONLY PER EO 10-2381 R2	04-11-93	PJD

FOR ON/OFF SWITCH
TIMER

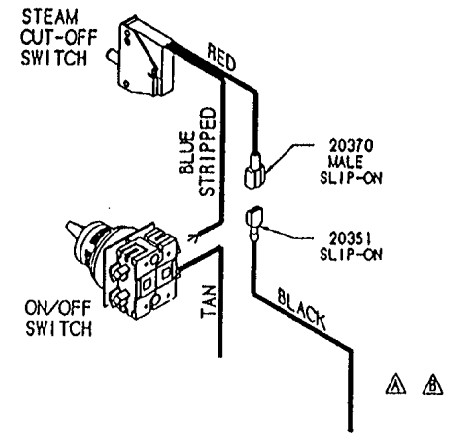

FROM: FLOAT (STANDARD)
GEN. STAND-BY TIMER (SBY OPTION)
BELL TERMINAL (TDS AND SBY OPTIONS TOGETHER)

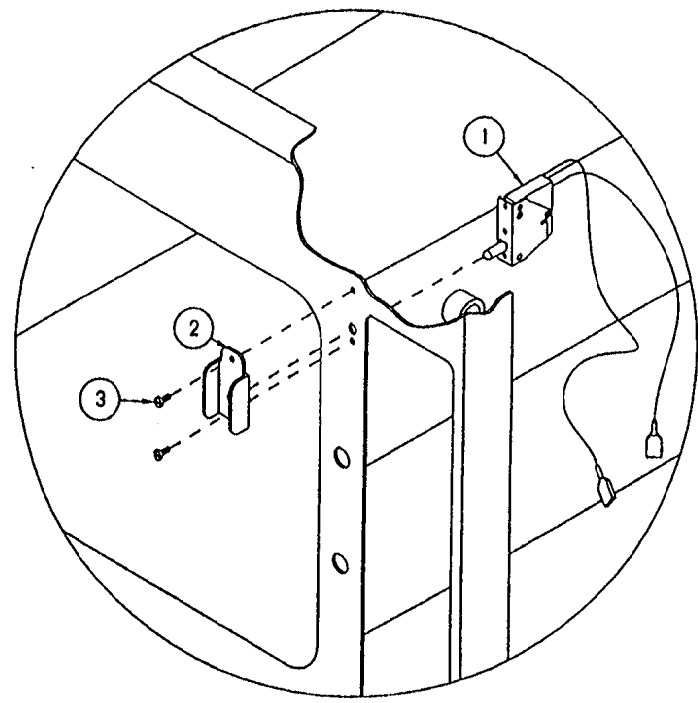

FOR ELECTRICAL & 60 MINUTE
MECHANICAL TIMERS

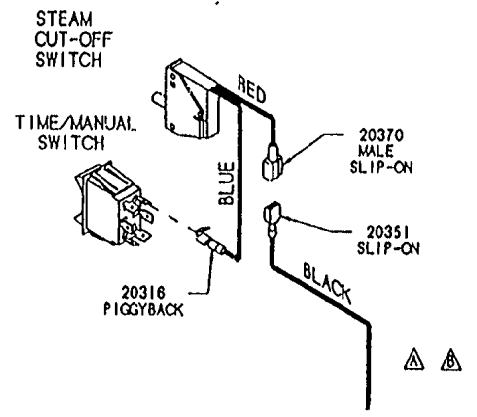

FROM: FLOAT (STANDARD)
GEN. STAND-BY TIMER (SBY OPTION)
BELL TERMINAL (TDS AND SBY OPTIONS TOGETHER)

ITEM	QTY.	PART NO.	DESCRIPTION
3	2	105449	SCREW, TRUSS HD. 6-32 X .312, S/S
2	1	105442	GUARD, SWITCH PROTECTION
1	1	104702	SWITCH, CMPT. STEAM SHUT-OFF

TOLERANCES (EXCEPT AS NOTED)		CLEVELAND RANGE INC. 1333 East 179th St., Cleveland, Ohio 44110-2574	
DECIMAL ± .030	SCALE N.T.S.	DRAWN BY DUTCHMAN	APPROVED BY
ANGULAR ± 1°	TITLE STEAM CUT-OFF OPTION STEAMCRAFT 3.1 AND 5.1		
CK	DATE 02-03-93	DRAWING NO. C - 106355	REV. B

THIS DESIGN DESCRIBES A PROPRIETARY ITEM
AND IS THE PROPERTY OF CLEVELAND RANGE.
THIS DRAWING IS NOT TO BE COPIED OR USED
WITHOUT THE APPROVAL OF CLEVELAND RANGE.

STEAMCRAFT 5.1 ELECTRONIC TIMER

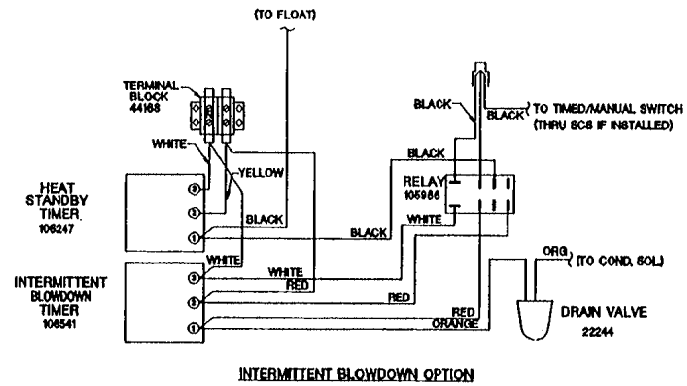
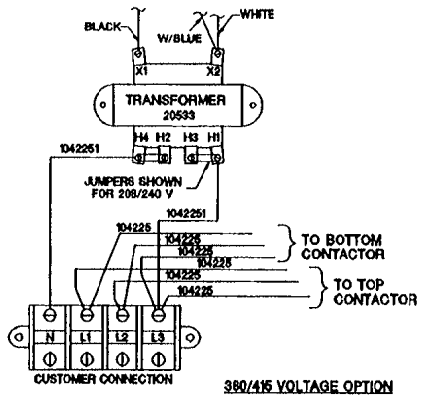
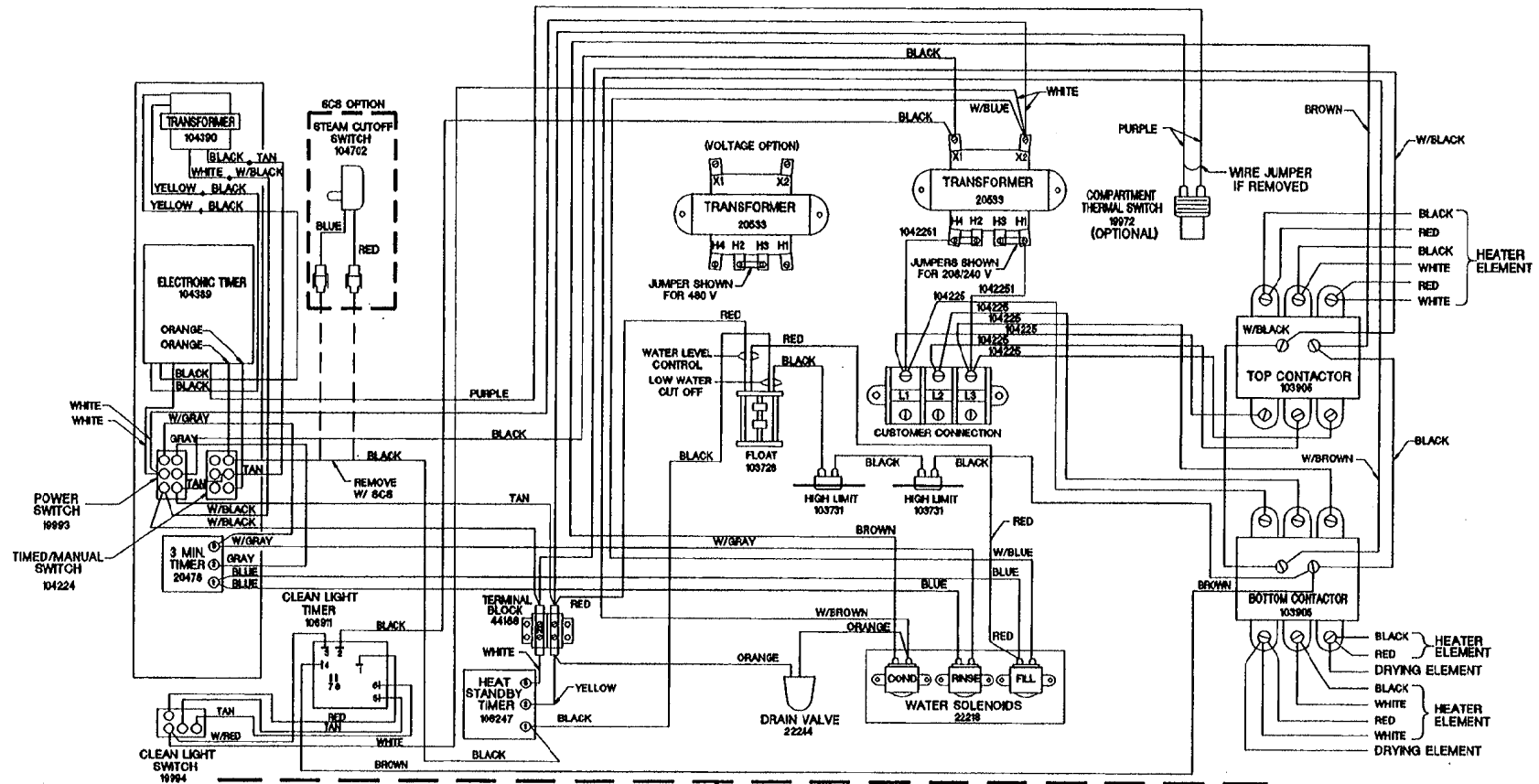

STEAMCRAFT 5.1 ON/OFF SWITCH

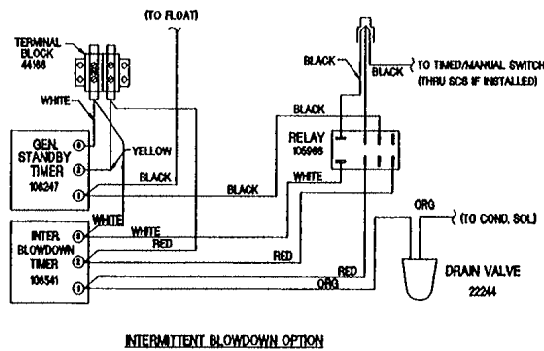
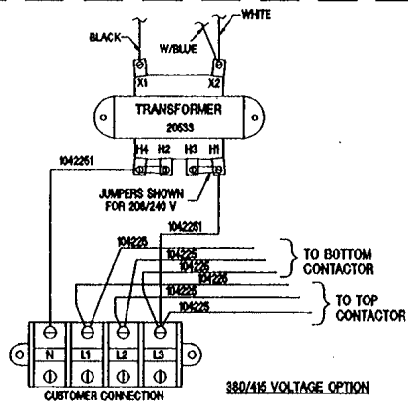
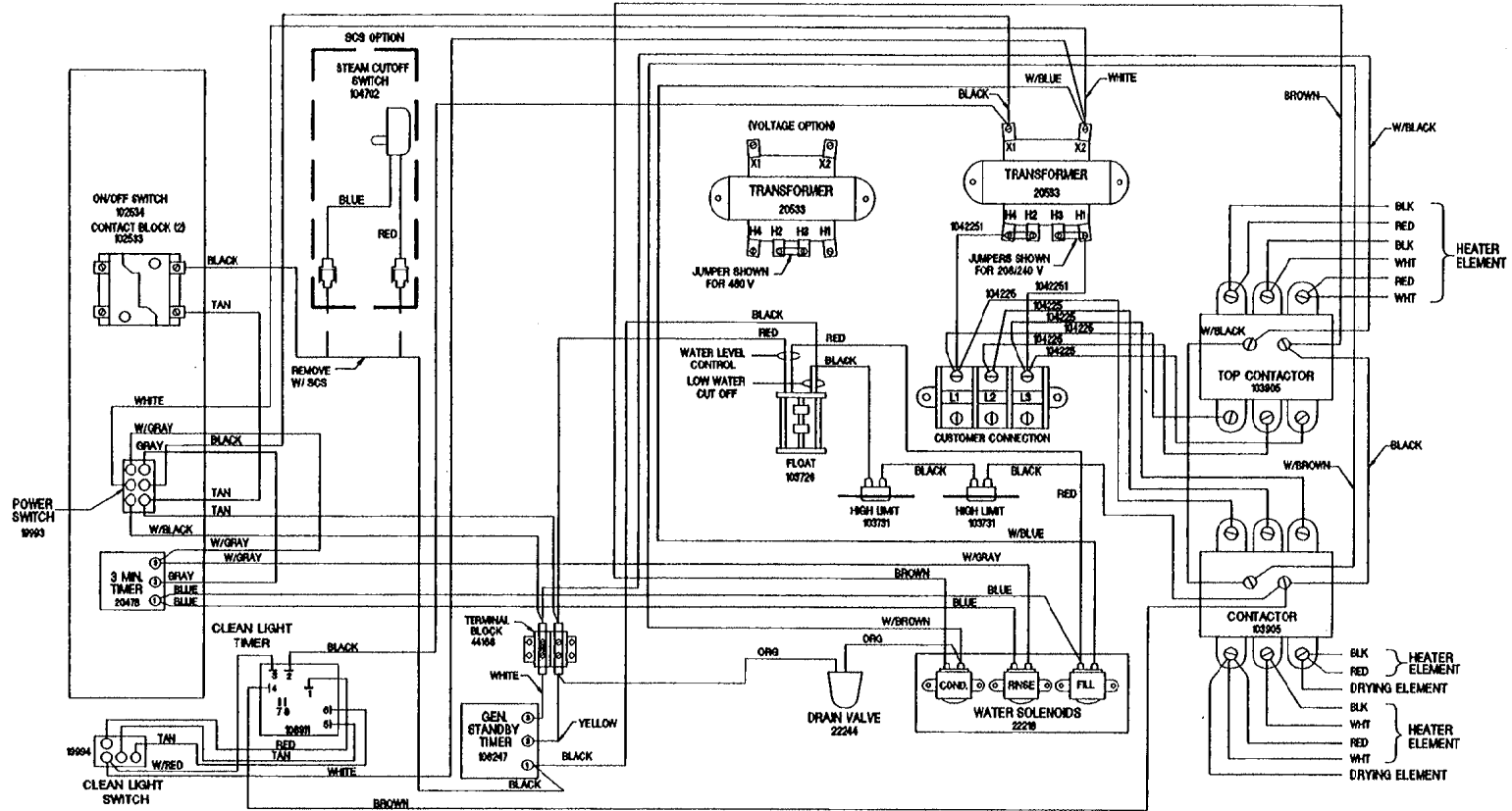

STEAMCRAFT 5.1 MECHANICAL TIMER

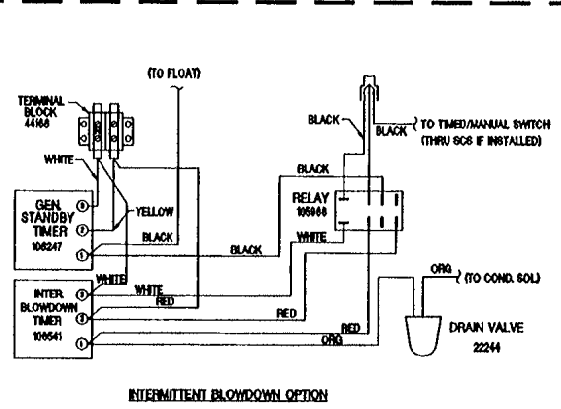
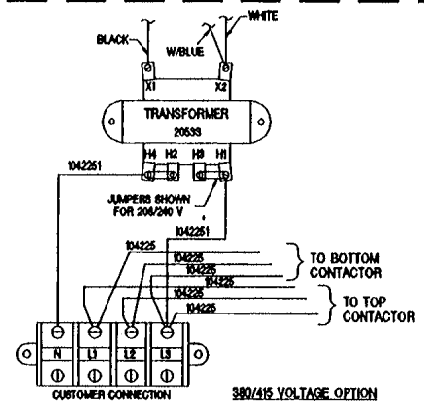
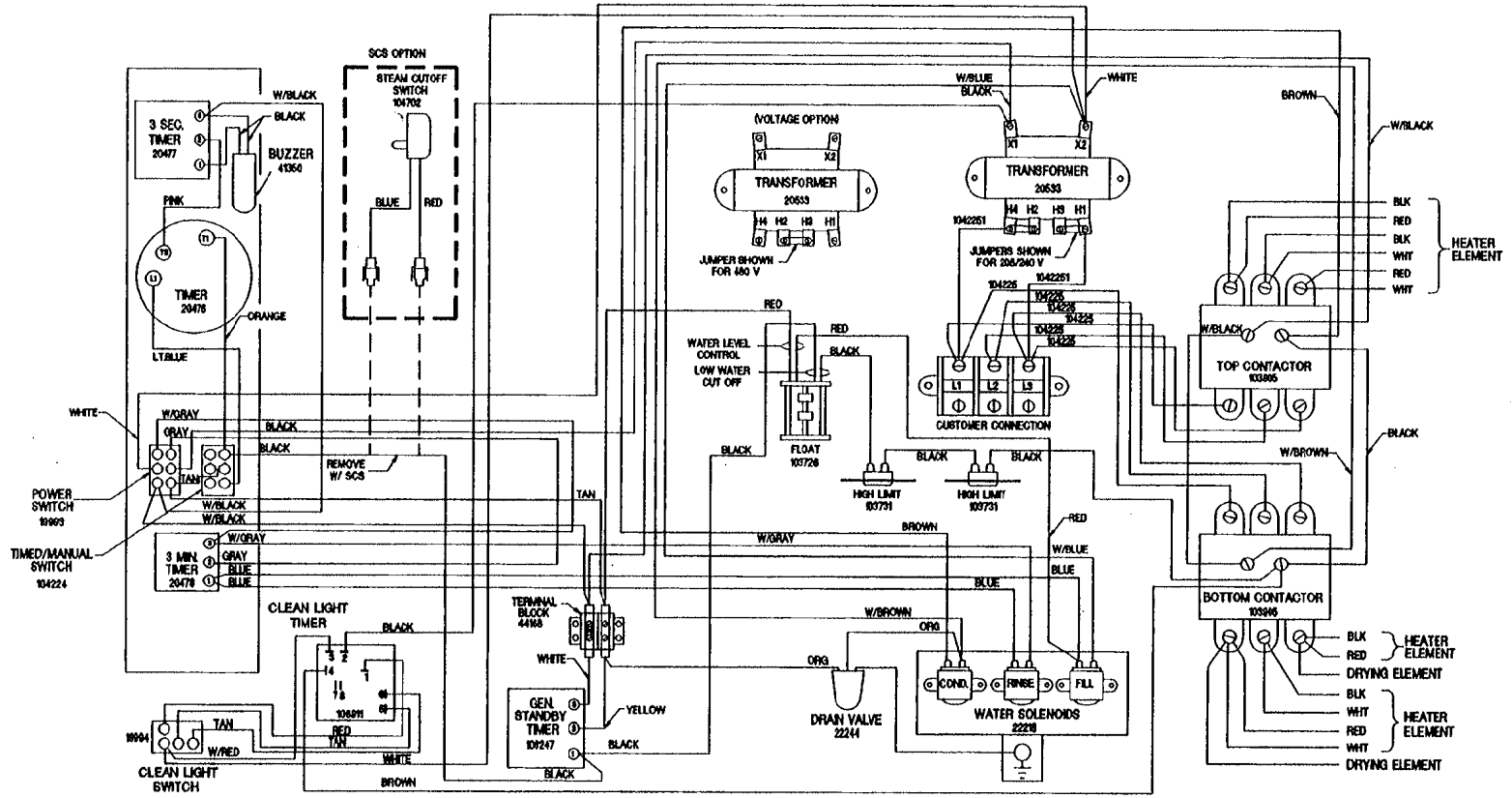

- BLK HEATER ELEMENT
- RED HEATER ELEMENT
- BLK HEATER ELEMENT
- WHT HEATER ELEMENT
- RED HEATER ELEMENT
- WHT HEATER ELEMENT
- BLK DRYING ELEMENT
- RED DRYING ELEMENT
- WHT DRYING ELEMENT

CLEVELAND RANGE 21CET16
SEQUENCE OF OPERATIONS
Mechanical Timer

1. Supply power is sent to the primary of the main transformer.
 - 115 VAC is sent from the secondary of the main transformer to the on/off rocker,

1. To turn the unit on, depress the red on/off rocker switch.
 - 115 VAC is sent to the red indicator light.
 - 115 VAC is sent to the normally open drain valve closing it.
 - 115 VAC is sent to H and N of the water level board

2. With the water level board energized and no water in the generator
 - After a 5 second delay, 115 VAC is sent from the FILL terminal to the fill solenoid.
 - The fill solenoid opens and the generator fills through the drain valve.
 - The water fills to the low probe shorting it to ground
 - 115 VAC is sent from the HEAT terminal to the timed manual switch.
 - 115 VAC is sent to the preheat thermostat.
 - 115 VAC is then sent through the high limits to the coil of condensate solenoid.
 - The condensate solenoid opens sending cold water down the compartment drain.
 - 115 VAC is also sent through the high limits to the coil of the contactor.
 - When the contactor is energized supply voltage is sent to both of the elements.
 - The heat circuit will stay energized until the preheat thermostat opens at 185 degrees.

3. When the timed/manual switch is in the timed position and time is on the timer
 - 115 VAC is sent from the timer to the coil of the R2 relay
 - The R2 relay energizes
 - R2B contacts close and 115 VAC is sent to the motor of the timer
 - R2A contacts close and 115 VAC is through the optional door switch to the normally closed contacts of the high limits
 - 115 VAC is then sent through the high limit to the coil of condensate solenoid and the coil of the mercury contactor.
 - 115 VAC is sent to the clean light timer.
 - When the clean light timer times down 115 VAC is sent to the clean light switch.
 - When the clean light switch is depressed the clean light timer is reset.

4. When the contactor is energized supply voltage is sent to both of the elements.

5. When the timer times out 115 VAC is sent to the 3 second timer and then to the buzzer for 3 seconds.

6. When the water level reaches the high probe then 115 VAC is removed form the FILL terminal and the fill solenoid is turned off.

7. After the water level drops below the high probe for 5 seconds 115 VAC is sent to the FILL terminal again.
8. The red on/off rocker switch is depressed and the unit is turned off.
 - 115 VAC is removed from the timer and heat circuits.
 - 115 VAC is removed from the normally open drain valve allowing the steamer to drain.
 - 115 VAC is sent to the 3-minute timer and the fill solenoid is energized for 3 minutes flushing the drain.

STEAMCRAFT 5.1 MECHANICAL TIMER

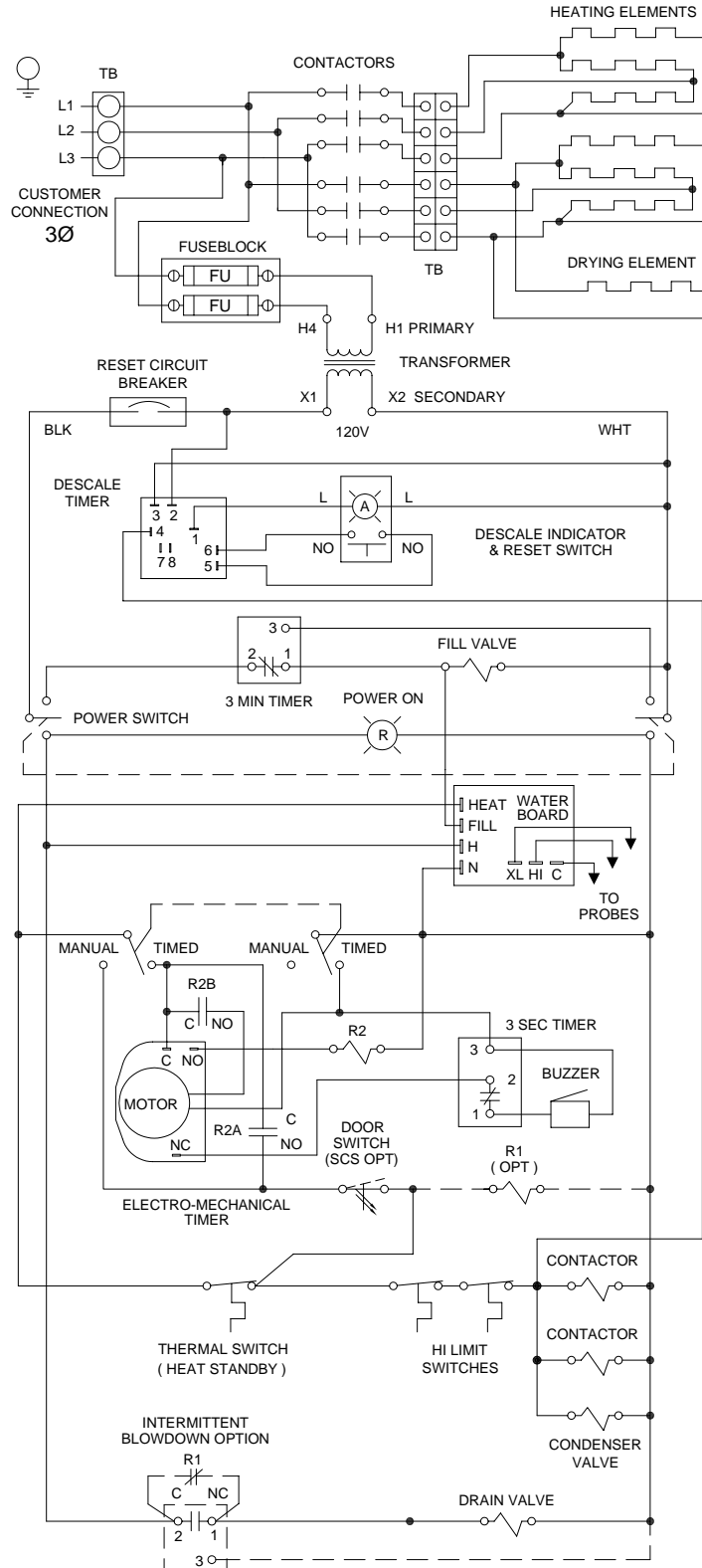
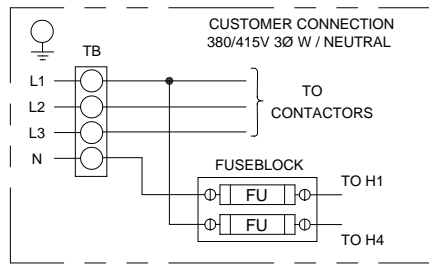

CLEVELAND RANGE 21CET16
SEQUENCE OF OPERATIONS
Electronic Timer
With preheat thermostat

1. Supply power is sent to the primary of the main transformer.
 - 115 VAC is sent from the secondary of the main transformer to the on/off rocker,
2. To turn the unit on, depress the red on/off rocker switch.
 - 115 VAC is sent to the red indicator light.
 - 115 VAC is sent to the normally open drain valve closing it.
 - 115 VAC is sent to H and N of the water level board
 - 115 VAC is sent to the 24 VAC transformer for the electronic timer.
 - 115 VAC is sent to the normally open compartment thermostat switch.
3. With the water level board energized and no water in the generator
 - After a 5 second delay 115 VAC is sent from the FILL terminal to the fill solenoid.
 - The fill solenoid opens and the generator fills through the drain valve.
 - The water fills to the low probe shorting it to ground
 - 115 VAC is sent from the HEAT terminal to the timed manual switch.
 - 115 VAC is sent to the preheat thermal switch.
 - 115 VAC is then sent through the high limit to the coil of condensate solenoid.
 - The condensate solenoid opens and cold water is sent down the compartment drain.
 - 115 VAC is also sent through the high limit to the coil of the contactor.
 - When the contactor is energized supply voltage is sent to both of the elements.
 - The heat circuit will stay energized until the preheat thermostat reaches 185 degrees.
4. When the timed/manual switch is in the timed position and time is on the timer
 - 115 VAC is sent from the timer through the door switch to the normally closed contacts of the high limit
 - 115 VAC is then sent through the high limit to the coil of condensate solenoid and the coil of the contactor.
 - 115 VAC is sent to the clean light timer.
 - When the clean light timer times down 115 VAC is sent to the clean light switch.
 - When the clean light switch is depressed the clean light timer is reset.
5. When the contactor is energized supply voltage is sent to both of the elements.
 - Steam is energized and sent to the cooking compartment.
 - When the cooking compartment reaches 193 degrees the compartment thermostat closes sending 115 VAC to the timer.
 - The timer will then begin counting down.

- When the timer times down a buzzer will sound and the timer will open removing 115 VAC from the heat circuit.
6. When the water level reaches the high probe then 115 VAC is removed from the FILL terminal and the fill solenoid is turned off.
 7. After the water level drops below the high probe for 5 seconds 115 VAC is sent to the FILL terminal again.
 8. The red on/off rocker switch is depressed and the unit is turned off.
 - 115 VAC is removed from the timer and heat circuit.
 - 115 VAC is removed from the normally open drain valve allowing the steamer to drain.
 - 115 VAC is sent to the 3-minute timer and the fill solenoid is energized for 3 minutes flushing the drain.

STEAMCRAFT 5.1 ELECTRONIC TIMER

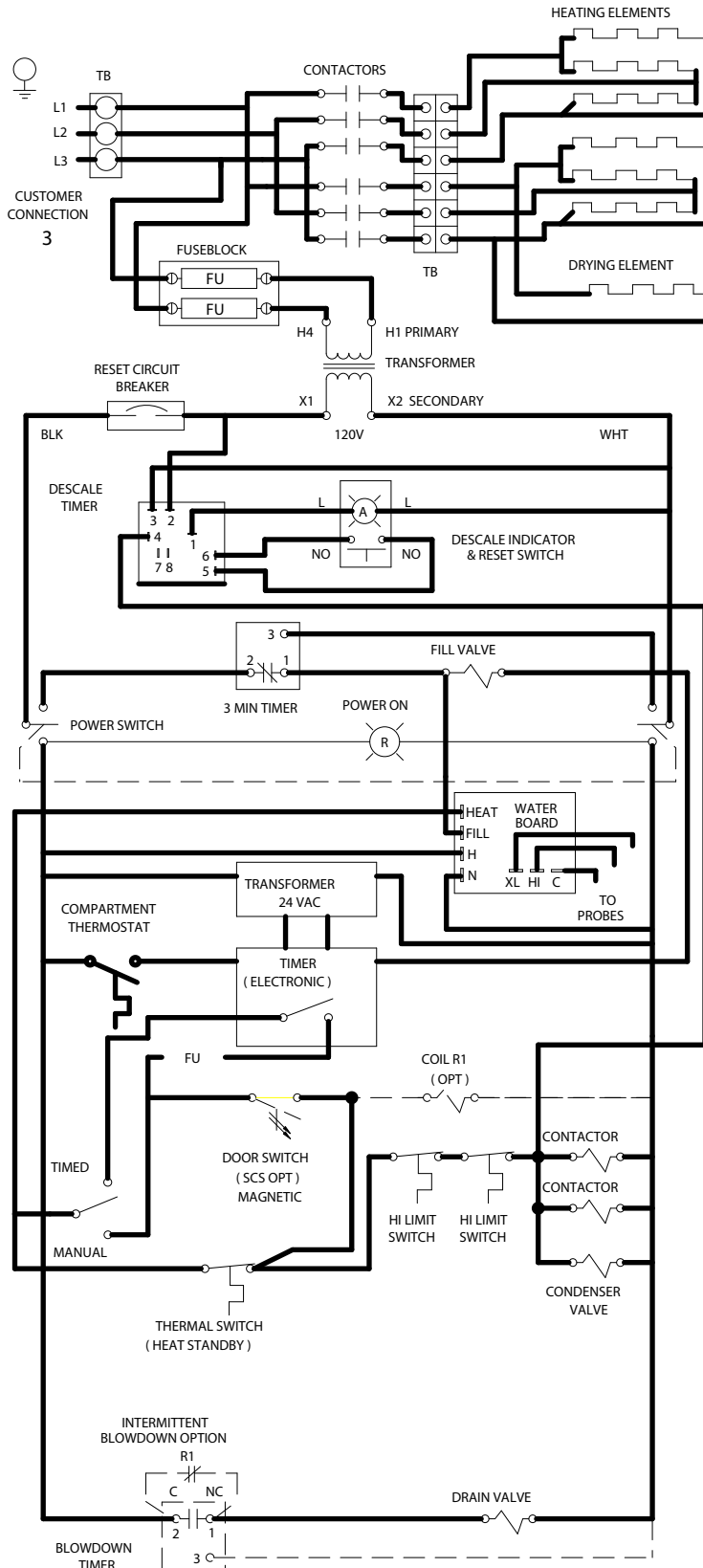
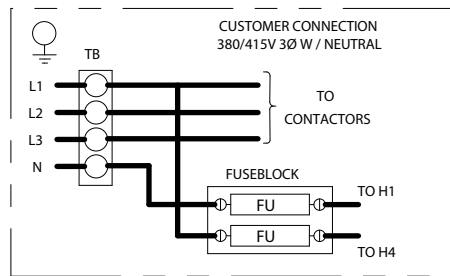

STEAMCRAFT 5.1 ELECTRONIC TIMER

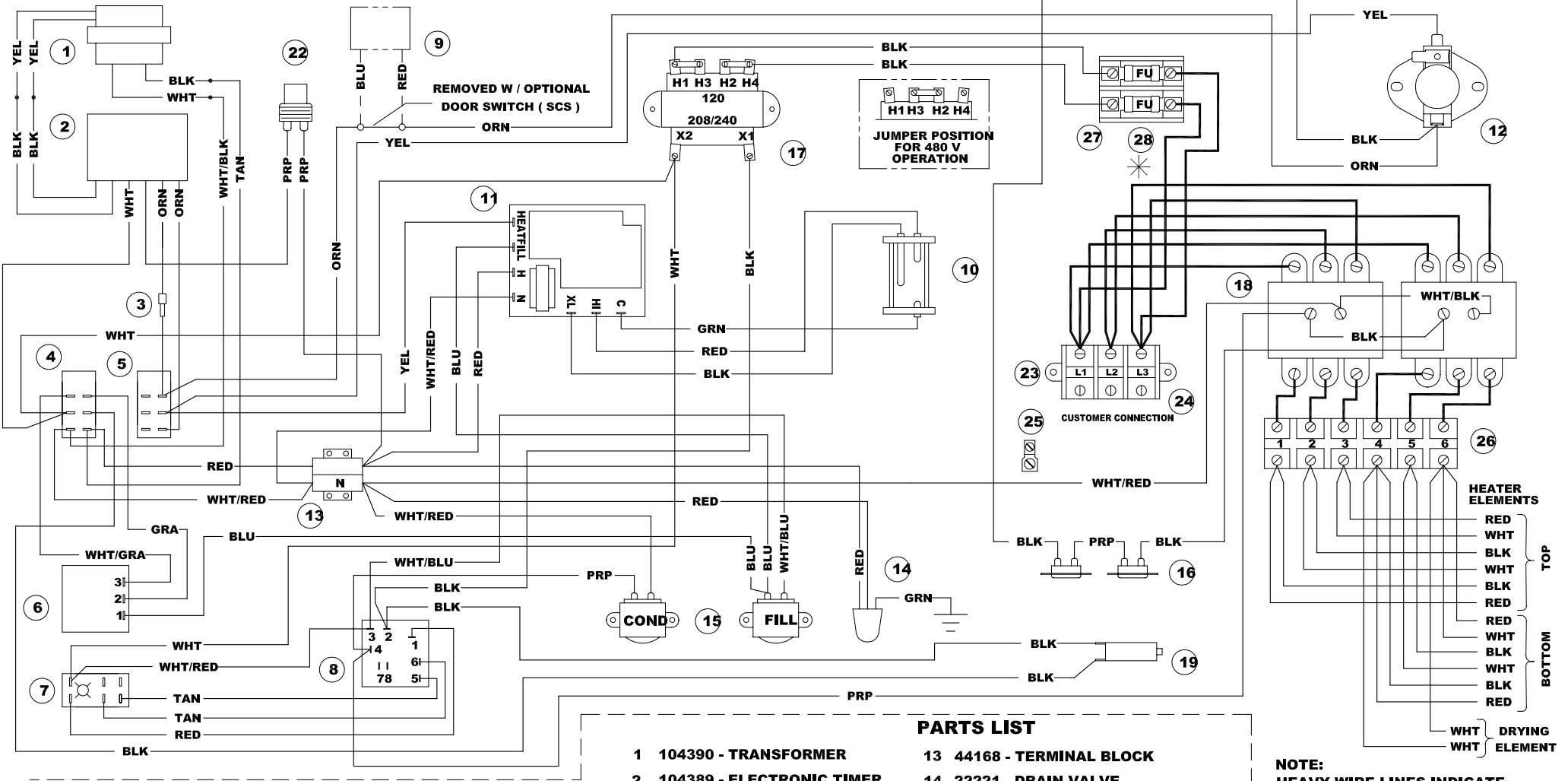

INTERMITTENT BLOWDOWN OPTION

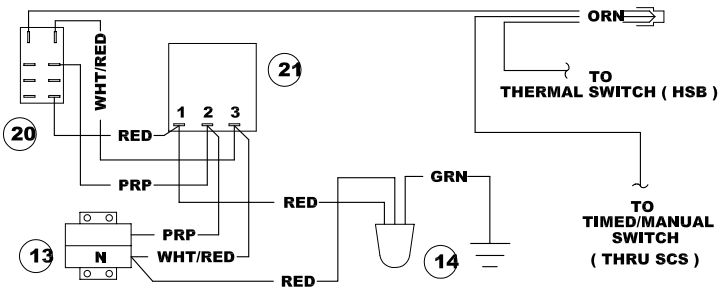

PARTS LIST

- | | | | |
|----|--|----|--|
| 1 | 104390 - TRANSFORMER | 13 | 44168 - TERMINAL BLOCK |
| 2 | 104389 - ELECTRONIC TIMER | 14 | 22221 - DRAIN VALVE |
| 3 | 106909 - 2 AMP, 250V FUSE | 15 | 22218 - WATER SOLENOIDS |
| 4 | 19993 - POWER SWITCH | 16 | 103731 - HI LIMIT SWITCH |
| 5 | 104224 - TIMED / MANUAL SWITCH | 17 | 20535 - TRANSFORMER |
| 6 | 20478 - 3 MIN TIMER | 18 | 103905 - CONTACTORS |
| 7 | 19994 - DESCALE INDICATOR & RESET SWITCH | 19 | 108331 - RESET CIRCUIT BREAKER |
| 8 | 106911 - DESCALE TIMER | 20 | 105966 - RELAY |
| 9 | 108880 - DOOR SW (SCS) MAG | 21 | 106541 - INTERMITTENT BLOWDOWN TIMER |
| 10 | 107239 - PROBE | 22 | 19972 - COMPARTMENT THERMAL SWITCH |
| 11 | 107241 - WATER BOARD | 23 | 101540 - END SEGMENT |
| 12 | 105789 - THERMAL SWITCH (HSB) | 24 | 101541 - TERMINAL BLOCK SECTIONAL |
| | | 25 | 20304 - GROUND LUG |
| | | 26 | 109240 - 6 POLE TERMINAL BLOCK |
| | | 27 | 109374 - FUSEBLOCK |
| | | 28 | 109380 - FUSE, 3.5 A (FOR 208 V & 240 V UNITS) |
| | | | 109381 - FUSE, 1.5 A (FOR 480 V UNITS) |
- * (SEE RATING PLATE)

NOTE:
HEAVY WIRE LINES INDICATE
12 AWG HI - TEMP WIRE

P106379 F

PROBLEM:
21CET8
21CET16
21CEA10
Steamer won't steam.

Steamer won't steam

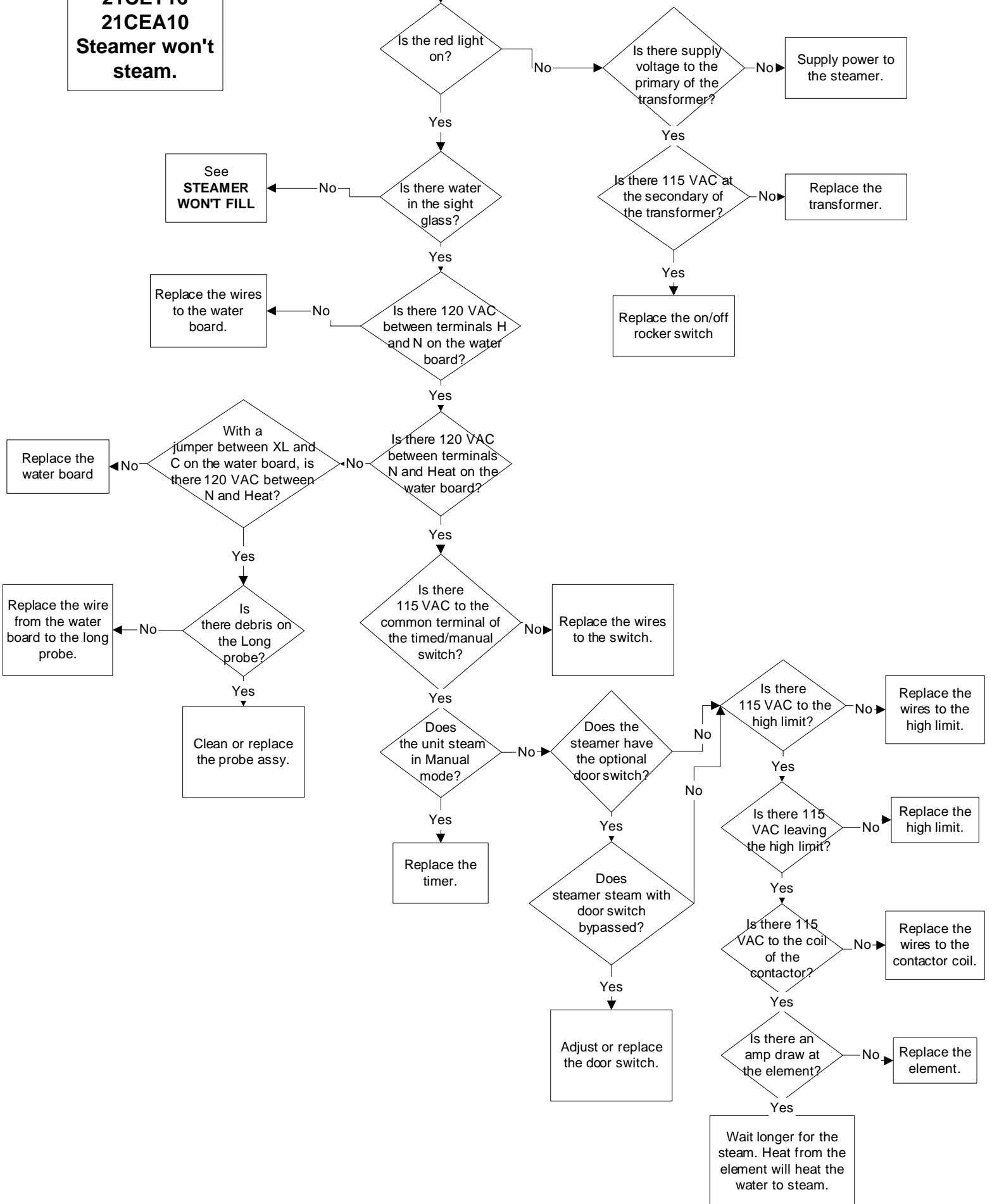

PROBLEM:
21CET8
21CET16
24CEA10
Steamer wont fill

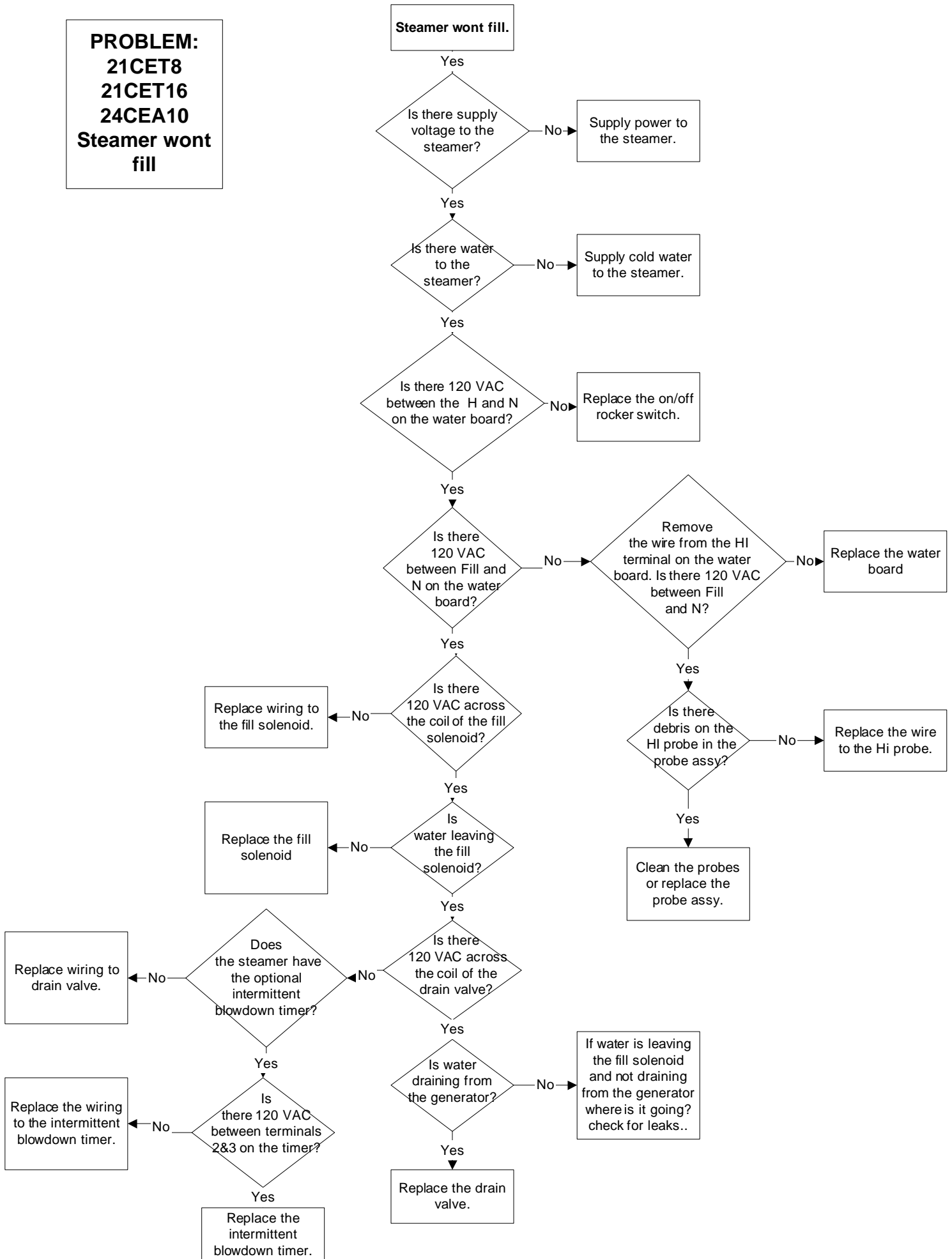

PROBLEM:
21CET8, 21CET16, 24CEA10
Electronic timer displays "PAUS" and won't count down

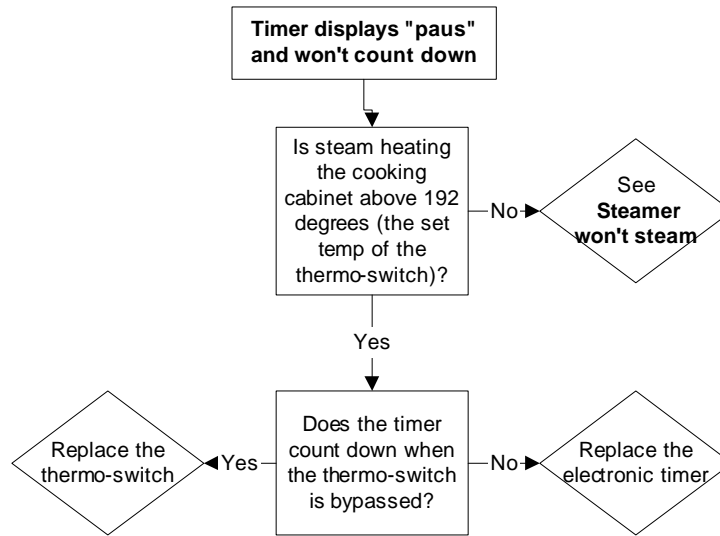

PROBLEM:
21CET8, 21CET16, 24CEA10
Steam leaks around the door.

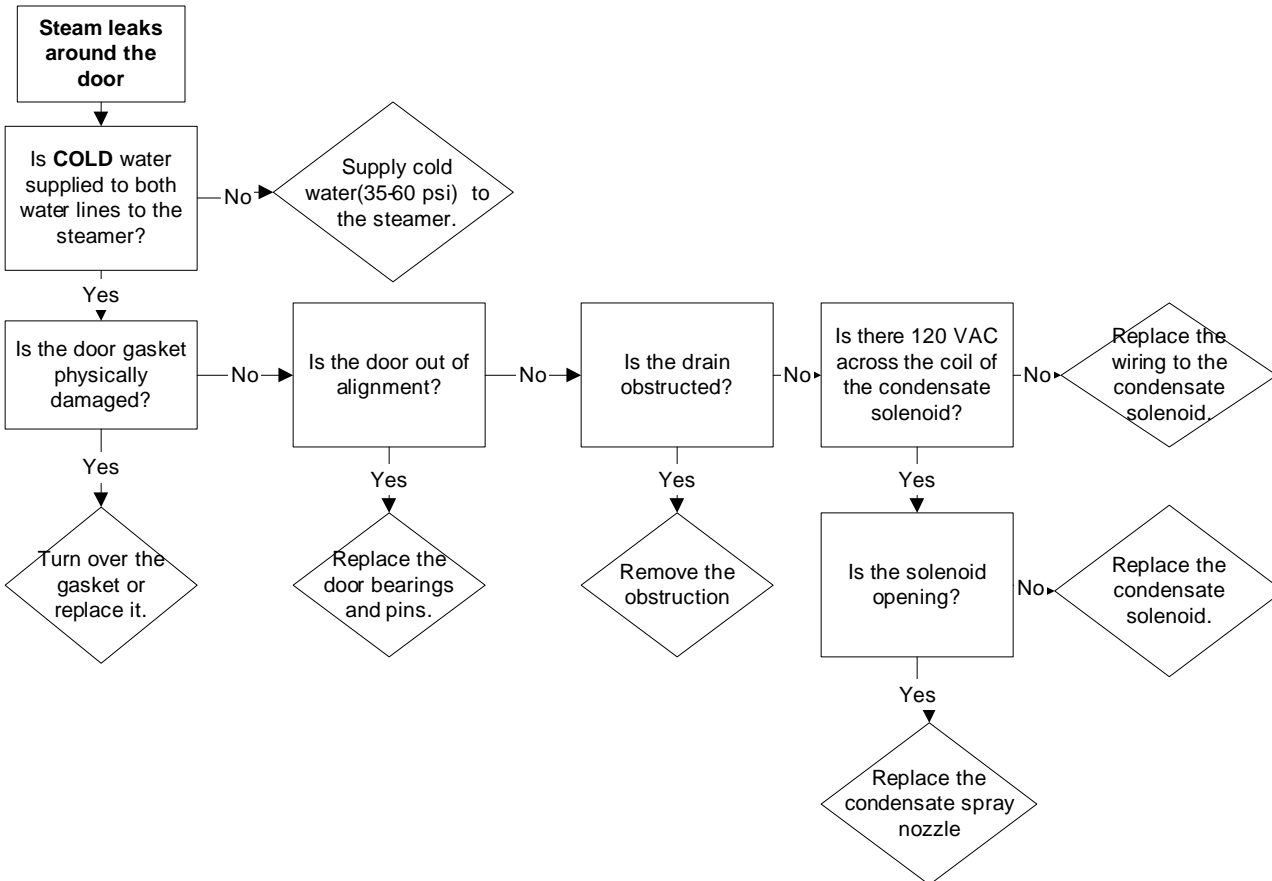

**PROBLEM:
21CET8
21CET16
24CEA10
Steamer overfills.
(Water sprays into cooking cabinet)**

**Steamer overfills
(Water sprays into the cooking cabinet)**

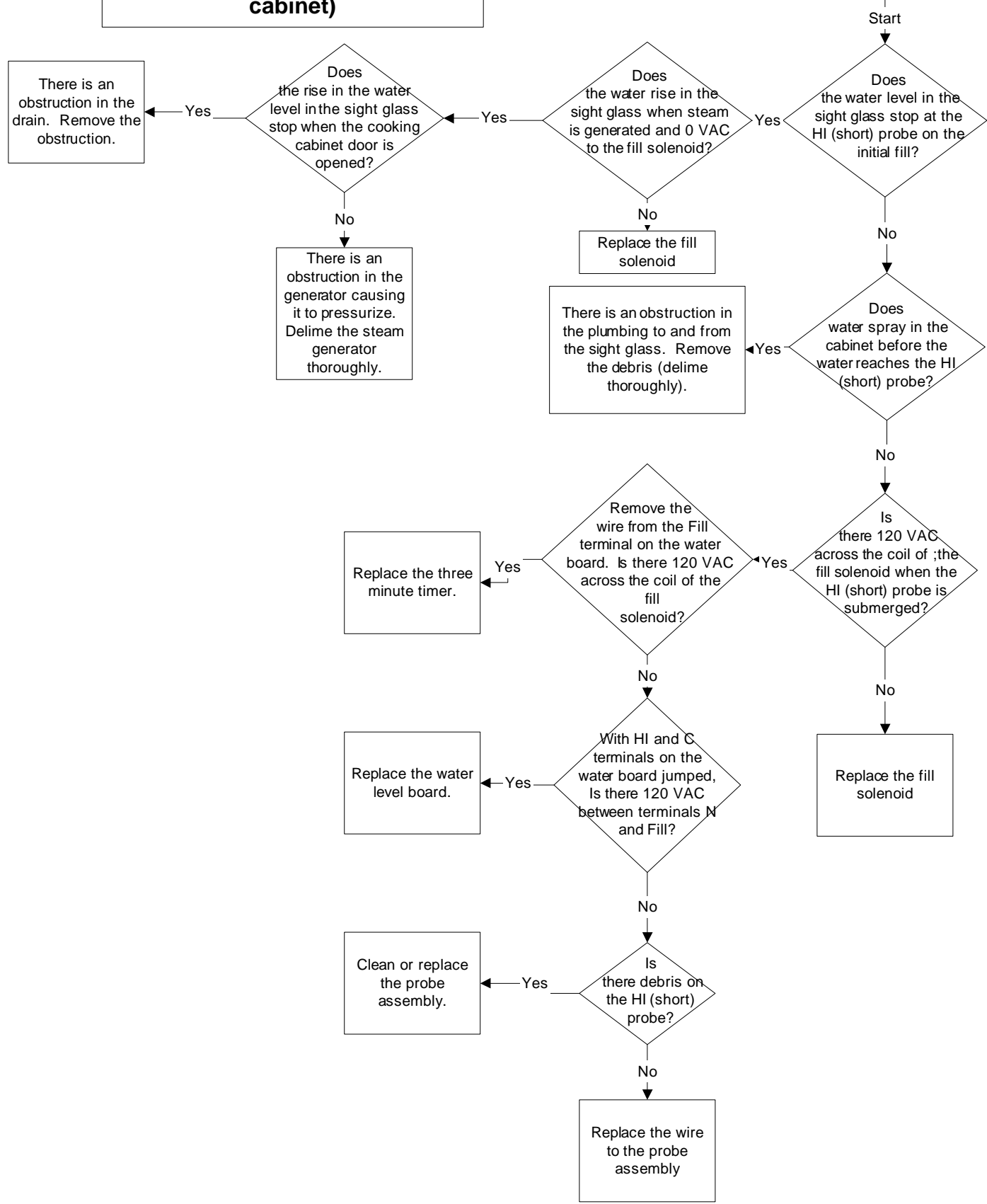

**PROBLEM:
21CET8
21CET16
24CEA10
Steamer won't stop steaming with
door open**

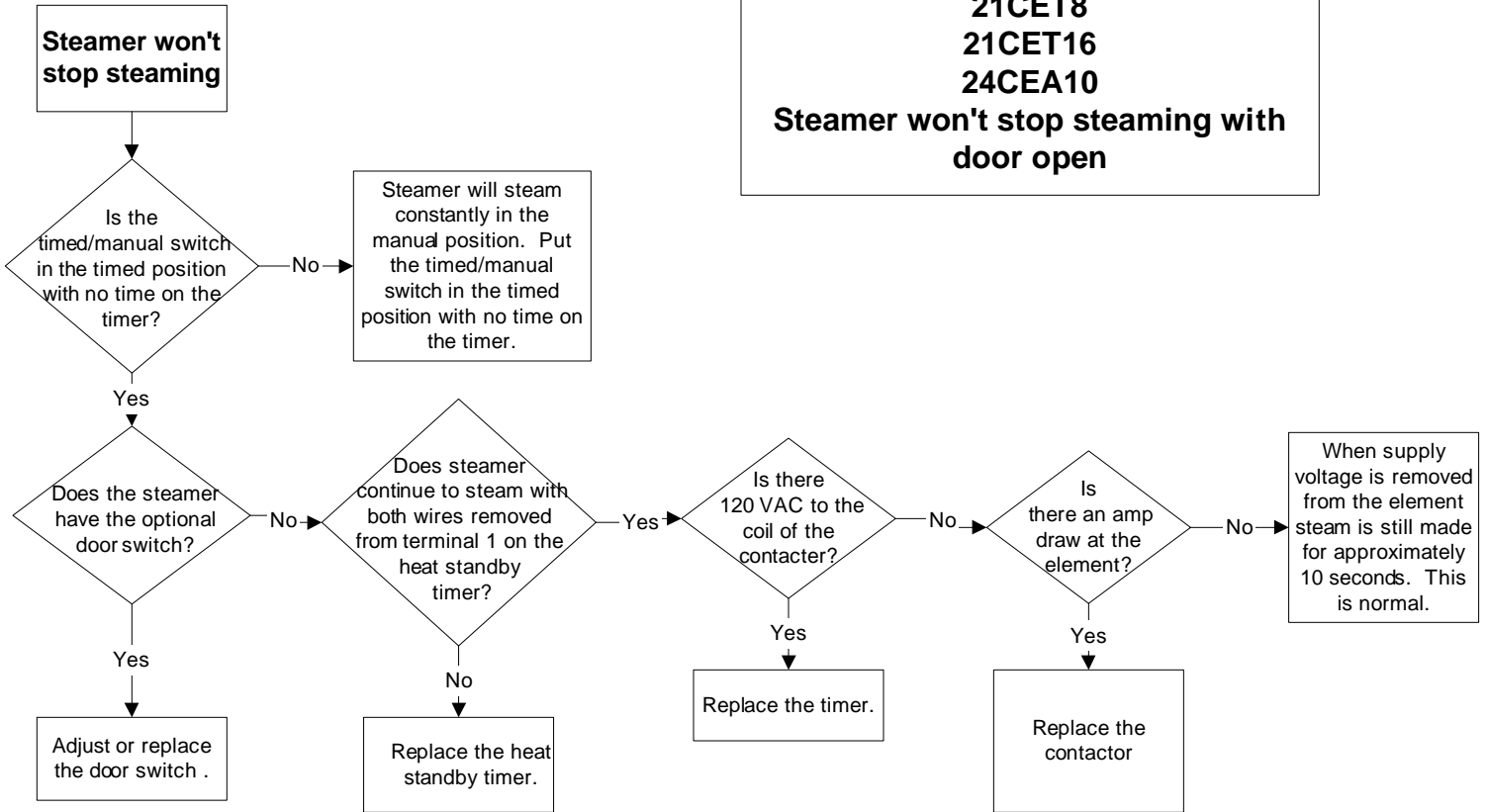

**Problem:
21CET8, 24CEA10
Steamer won't preheat**

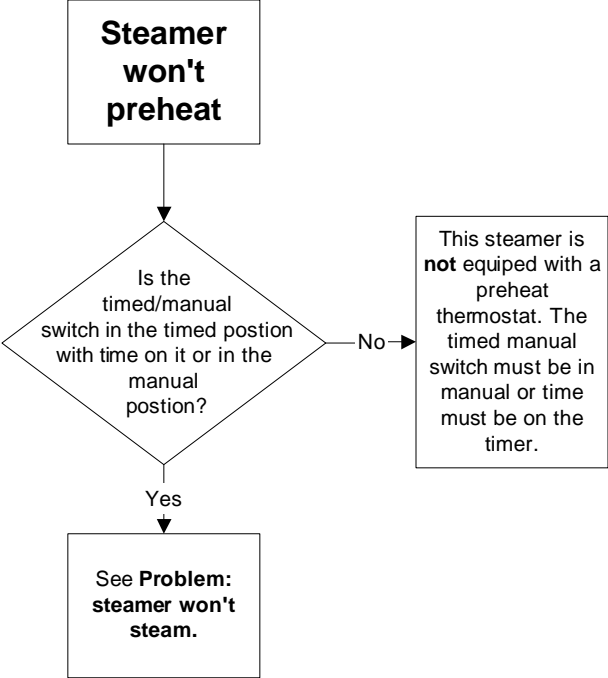

**Problem:
21CET16
Steamer won't preheat**

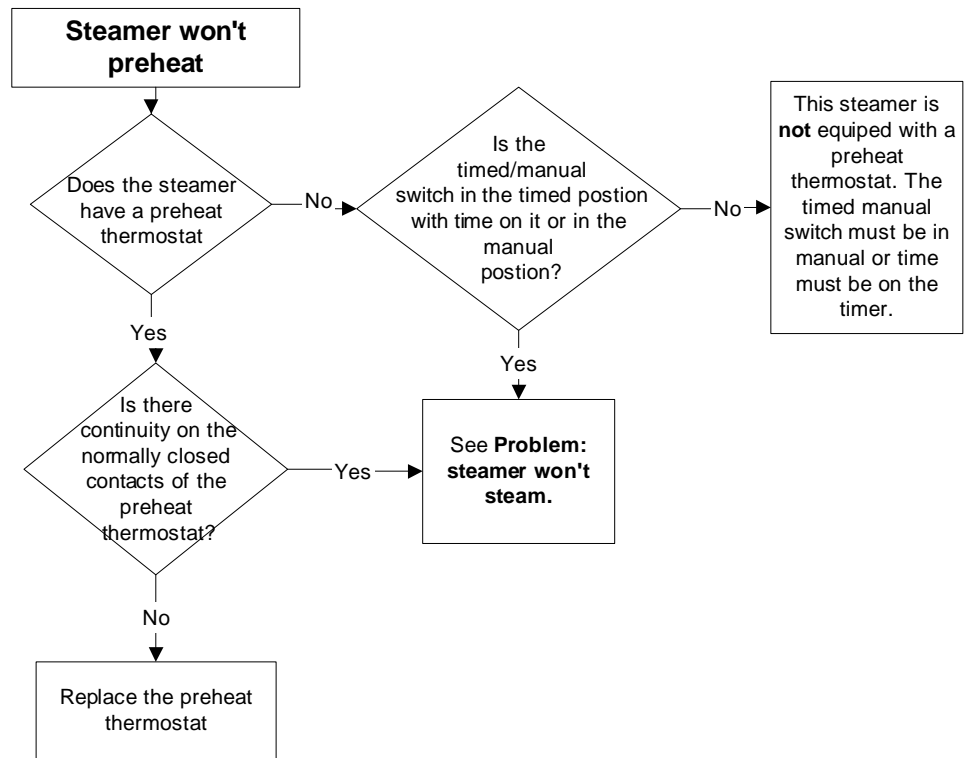

STEAMCRAFT 3.1 / 5.1 ELECTRONIC TIMER (PROBE)

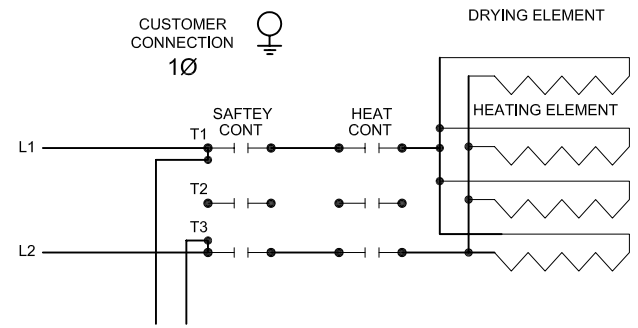
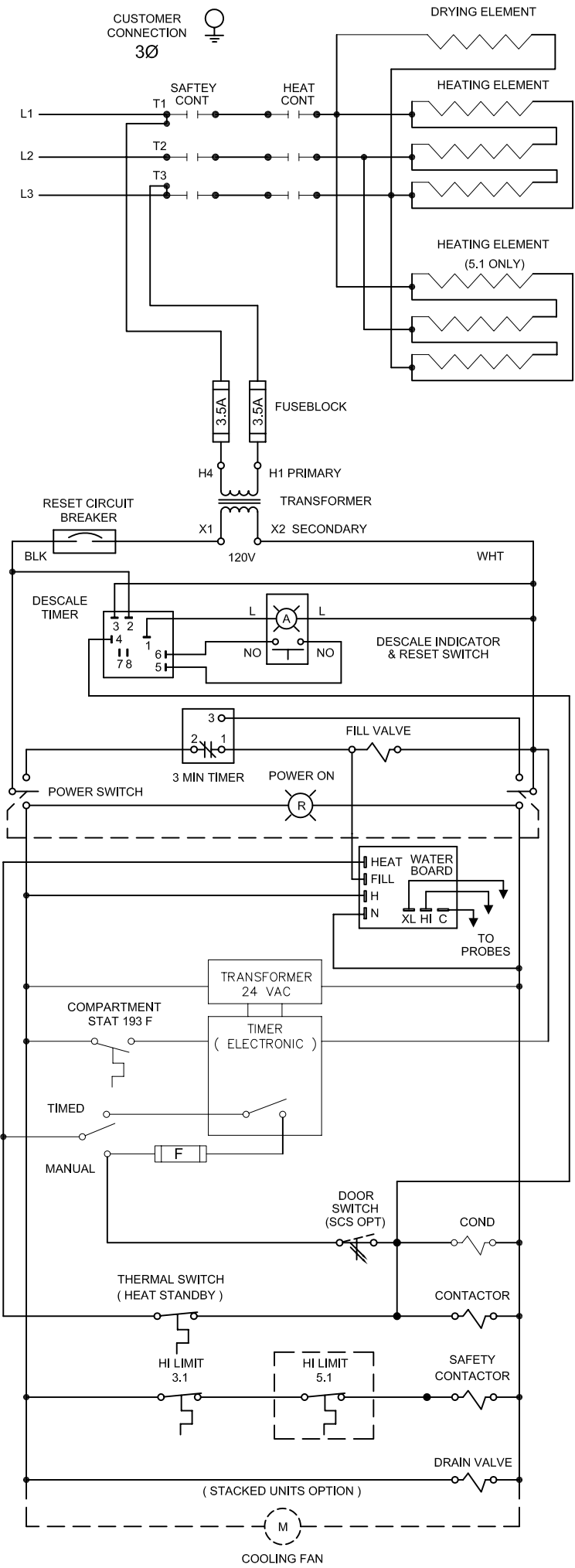

STEAMCRAFT 3.1 / 5.1 ELECTRONIC TIMER (PROBE)

CUSTOMER CONNECT AT SAFETY CONTACTOR T1,2 & 3 FOR 3 Ø FOR 1 Ø (3.1 ONLY) SEE SHEET 2

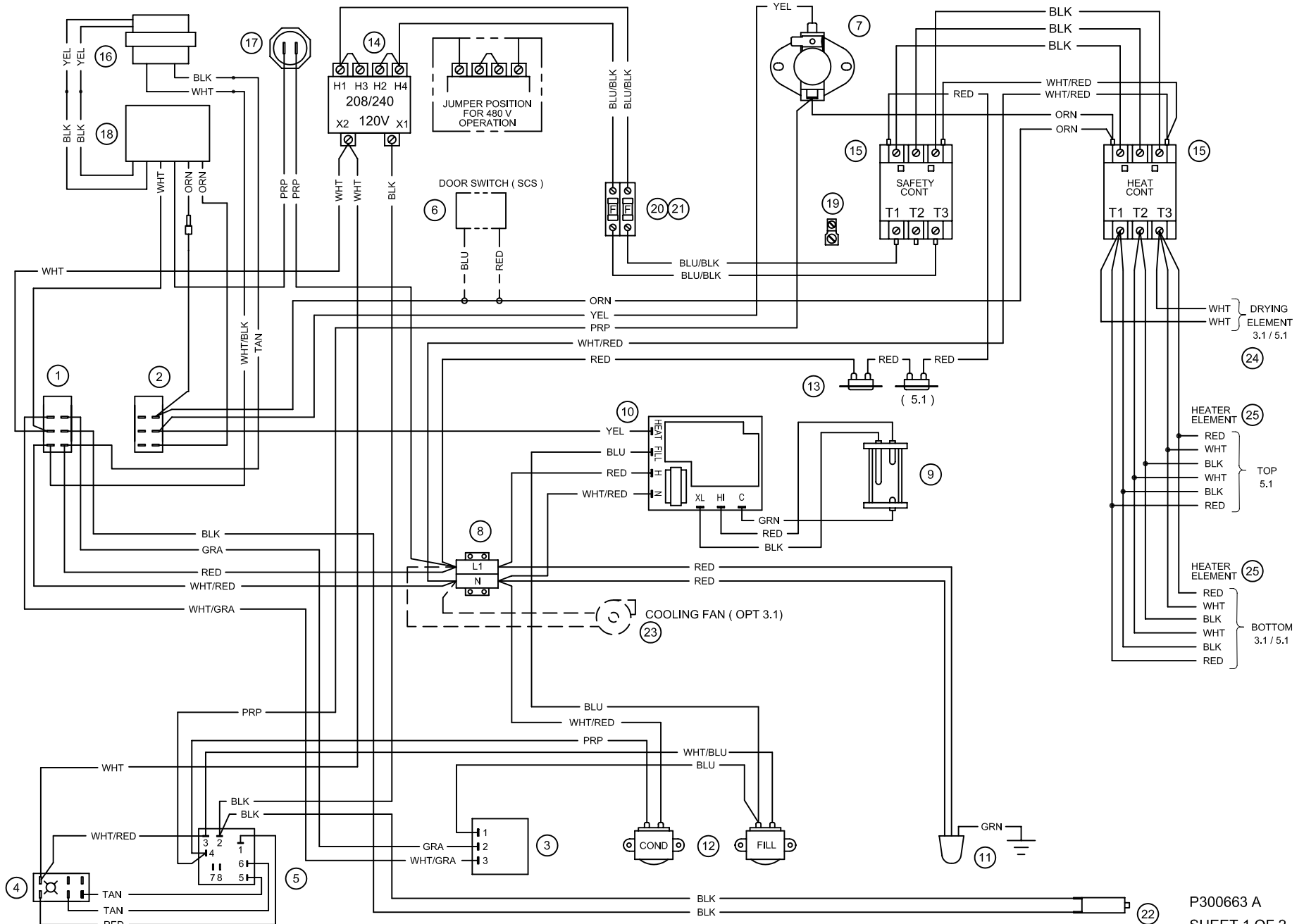

PARTS LIST

1 19993 - POWER SWITCH	6 108880 - DOOR SW (MAGNETIC)	11 22221 - DRAIN VALVE	16 104390 - TRANSFORMER
2 104224 - TIMED/MANUAL SWITCH	7 105789 - THERMAL SWITCH (HSB)	12 22218 - WATER SOLENOIDS	17 19972 - COMP THERMAL SW
3 20478 - 3 MIN TIMER	8 44168 - TERMINAL BLOCK	13 103731 - HI LIMIT SWITCHES	18 104389 - ELECTRONIC TIMER
4 19994 - DESCALE INDICATOR RESET SW	9 107239 - PROBE	14 20535 - TRANSFORMER	19 20304 - GROUND LUG
5 106911 - DESCALE TIMER	10 107241 - WATER BOARD	15 03509 - CONTACTORS	20 109374 - FUSE BLOCK
			21 109380 - FUSE, 3.5A
			22 108331 - RESET CIRCUIT BREAKER
			23 107211 - COOLIN FAN (OPT 3.1)

STEAMCRAFT 3.1 / 5.1 MECHANICAL TIMER (PROBE)

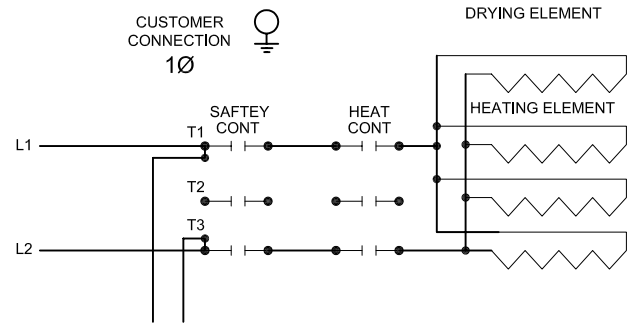
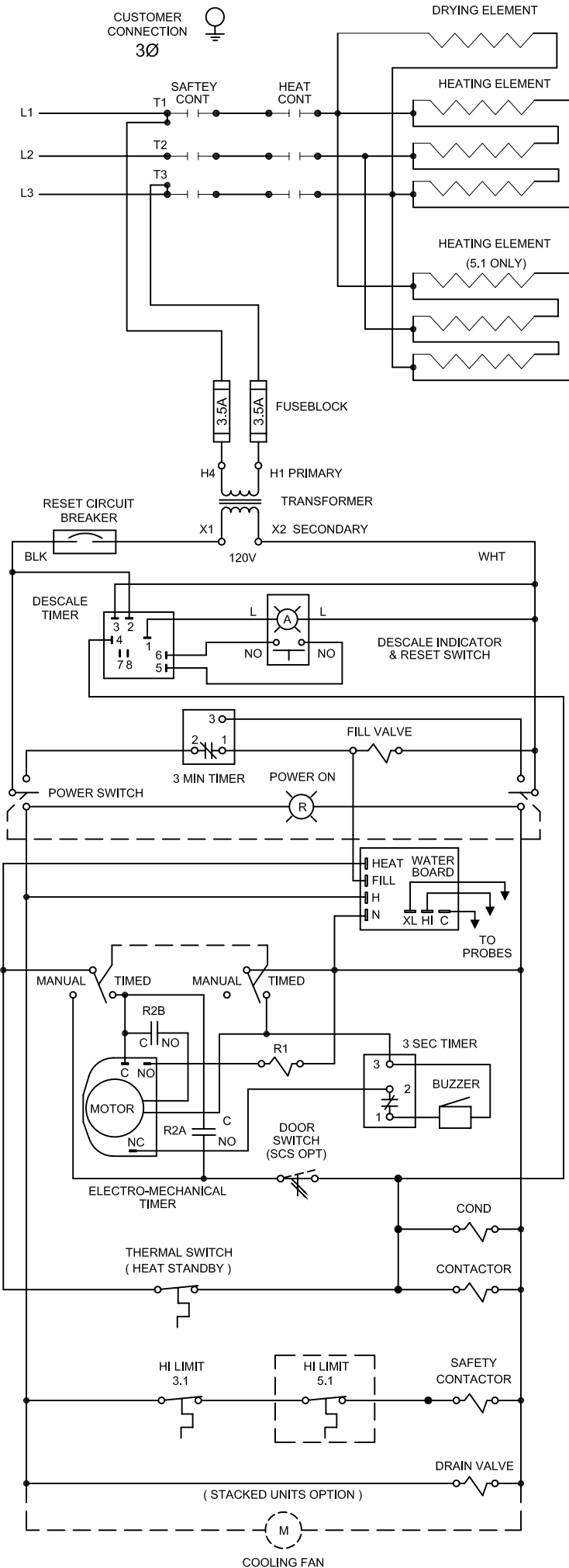

STEAMCRAFT 3.1 / 5.1 MECHANICAL TIMER (PROBE)

CUSTOMER CONNECT AT SAFETY CONTACTOR T1,2 & 3 FOR 3 Ø FOR 1 Ø (3.1 ONLY) SEE SHEET 2

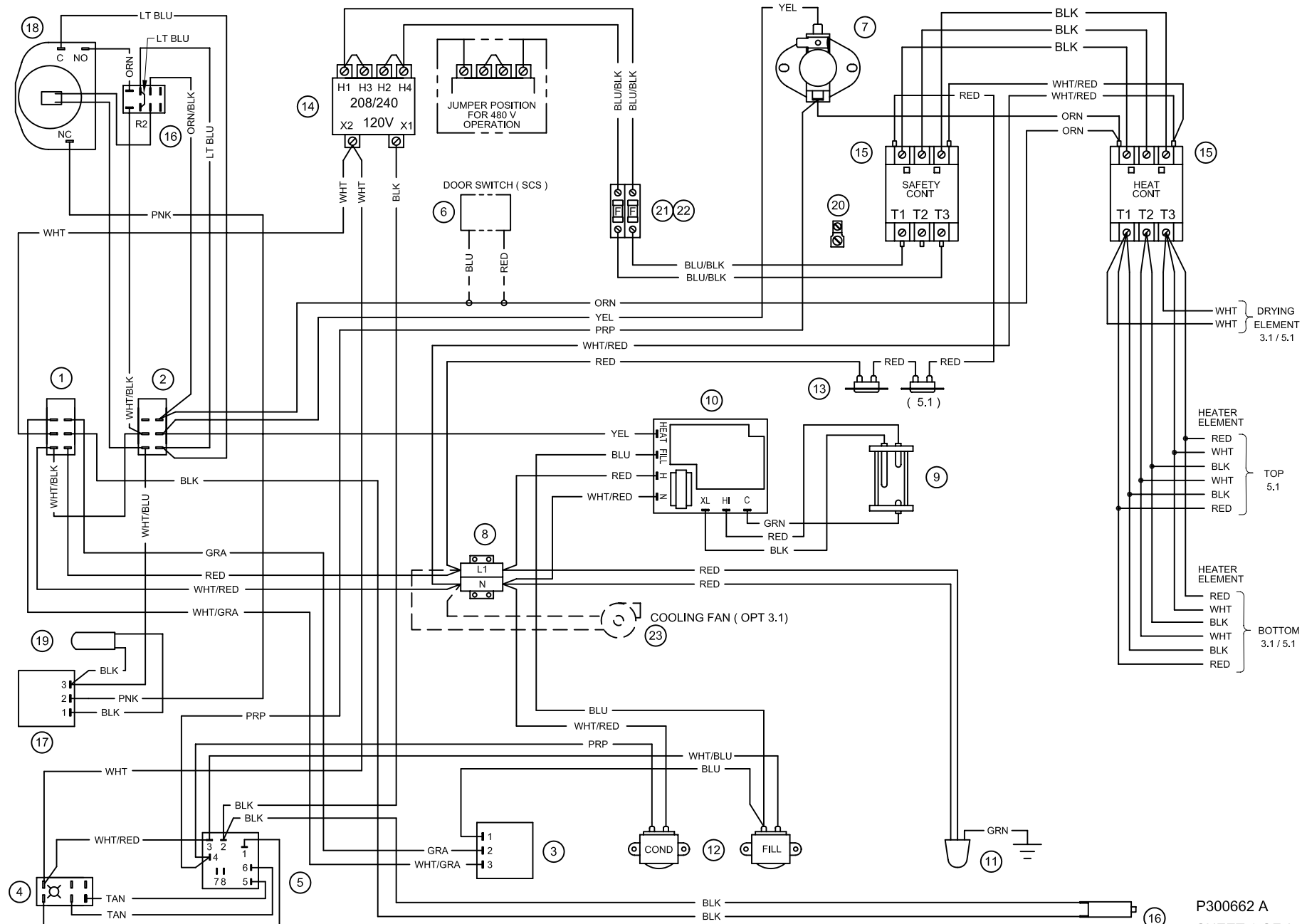

PARTS LIST

1 19993 - POWER SWITCH	6 108880 - DOOR SW (MAGNETIC)	11 22221 - DRAIN VALVE	16 105966 - RELAY
2 104224 - TIMED/MANUAL SWITCH	7 105789 - THERMAL SWITCH (HSB)	12 22218 - WATER SOLENOIDS	17 20477 - 3 SEC TIMER
3 20478 - 3 MIN TIMER	8 44168 - TERMINAL BLOCK	13 103731 - HI LIMIT SWITCHES	21 109374 - FUSE BLOCK
4 19994 - DESCALE INDICATOR RESET SW	9 107239 - PROBE	14 20535 - TRANSFORMER	22 109380 - FUSE, 3.5A
5 106911 - DESCALE TIMER	10 107241 - WATER BOARD	15 03509 - CONTACTORS	23 107211 - COOLIN FAN (OPT 3.1)



Cleveland

Descaling Procedure-SteamCraft Ultra and Gemini Series

How Much DISSOLVE to Use

Model	Dissolve
Ultra 3	1/2 Gallon
Ultra 5	1 Gallon
Ultra 10 (Elec.)	1 Gallon (ea.)
Ultra 10 (Gas)	1½ Gallon
Gemini 6 & 10	1 Gallon (ea.)

1. Turn the unit OFF and open the doors:

This will drain and rinse the generator for about 3 minutes.

2. Turn the unit power back On:

The generator will begin to refill with water.

3. Select Timed with the Timed/Manual switch:

DO NOT start the timer, since you do not want to heat the water during descaling. Leave the doors open.

4. Remove descaling port cap and add with the specified amount of DISSOLVE: (See chart above)

Do this while the unit is refilling. The generators can take-up to 8 minutes to refill.

5. After refill has stopped, add extra tap water into the descaling port until liquid is seen entering the cooking cabinet. Note: Ultra 10 gas will have liquid coming out of the drain,

Adding extra water when descaling will raise the descaling solution higher than the normal fill level, allowing the DISSOLVE to work on sensors and surfaces above the water line

Note: Some SteamCraft Ultra models (the electric powered Ultra 10 and Gemini 6 and 10, for example) have two generators and two descaling ports. Both units should be descaled at the same time, using this procedure

6. Let the descaler soak in generator for approximately one hour:

7. After one hour, turn the unit power Off: This will drain and rinse the generator for about 3 minutes.



8. After the 3-minute drain cycle completes, turn the unit back ON. After the filling has stopped, add water until liquid enters the cooking compartment (or drain for the ultra 10 gas), and then turn the unit OFF. This will drain and flush any residue from the water level control assembly. Replace descaling cap.

9. After the 3 minute drain cycle completes, Turn the unit ON and set the Timer for 20 minutes: Make sure the Time/Manual switch is in the timed setting and the doors are closed.

10. When the timer times out (after 20 minutes) turn the power Off:

This will drain and rinse the generator for about 3 minutes.

This ends the descaling procedure. You can now turn the unit back on and resume normal startup and cooking operations.