

## Statement of Responsibilities

This document is for use by experienced and trained Qualified Cleveland Range, LLC Authorized Service Representatives who are familiar with both the safety procedures, and equipment they service.

Cleveland Range, LLC assumes no liability for any death, injury, equipment damage, or property damage resulting from use of, improper use of, or failure to use the information contained in this document.

Cleveland Range, LLC has made every effort to provide accurate information in this document, but cannot guarantee that this document does not contain unintentional errors and omissions.

The information in this document may be subject to technical and technological changes, revisions, or updates.

Cleveland Range, LLC assumes no liability or responsibility regarding errata, changes, revisions, or updates.

Qualified Cleveland Range, LLC Authorized Service Representatives are obligated to follow industry standard safety procedures, including, but not limited to, OSHA regulations, and disconnect / lock out / tag out procedures for all utilities including steam, and disconnect / lock out / tag out procedures for gas, electric, and steam powered equipment and / or appliances

All utilities (gas, electric, water and steam) should be turned OFF to the equipment and locked out of operation according to OSHA approved practices during any servicing of Cleveland Range equipment

Qualified Cleveland Range, LLC Authorized Service Representatives are obligated to maintain up-to-date knowledge, skills, materials and equipment.

## SteamCraft® Ultra 10

TWO COMPARTMENT FLOOR MODEL DESIGN  
PRESSURELESS CONVECTION STEAMER  
Twin Electric Steam Generators, 16 KW each

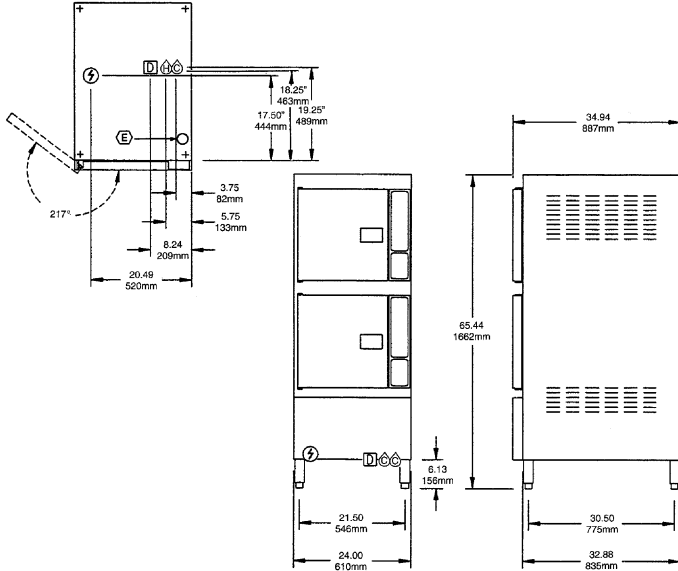

MODEL:  24-CEA-10

ITEM NUMBER \_\_\_\_\_

JOB NAME / NUMBER \_\_\_\_\_

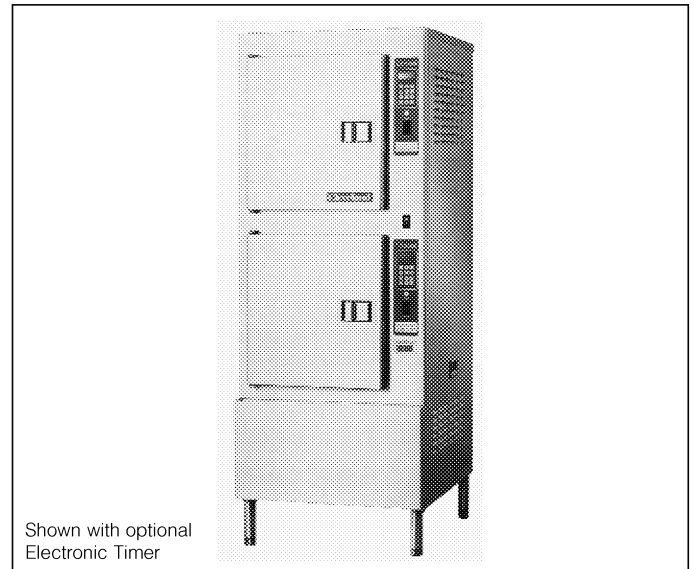

Shown with optional Electronic Timer

### SHORT FORM SPECIFICATION

Shall be Two Compartments, Cleveland Convection Steamer series **SteamCraft® Ultra 10**, Model 24-CEA-10, Twin Electric Atmospheric Steam Generator, 32 KW input. Remote Probe Type Water Level Controls. Steam Generator with Automatic Water Fill on start up. Automatic Generator Blowdown, Two each 16.5 KW Fire Bar Heating Elements. Choice of Compartment Controls, Manual By Pass Operation Mode, Compensating Thermostat, Patented Cold Water Condenser design, Type 430 Stainless Steel exterior and cooking compartments.

UTILITY CONNECTIONS			
(A) Electrical Supply	(D) Drain: 1.50" (38mm) Dia.	(E) Inlet for Generator Delimiting Solution	
(B) Cold Water Supply for Condenser 3/8" Dia. IPS			
(C) Cold Water Supply for Generator and Water Injection. 3/8" Dia. IPS (for water treatment conn.) Unit comes with a 50 Mesh Water Strainer (installation required)			
TOTAL CAPACITY (2 Compartments)			
10 — 12" x 20" x 2 1/2" Cafeteria Pans or 20 — 12" x 20" x 1" Cafeteria Pans or 6 — 12" x 20" x 4" Cafeteria Pans			
ELECTRIC ⚡		COLD WATER Ⓒ	
STANDARD ELECTRIC		35 psi minimum 60 psi maximum	
<b>VOLTS</b>	<b>KW</b>	<b>3PH AMPS</b>	Ⓒ 3/8" Dia. IPS for Generator (for water treatment connection) Ⓒ 3/8" Dia. IPS for Condenser
208	32	92	
220	30	80	
240	36	88	
440	30	40	
480	36	44	
LOW WATTAGE OPTION		<b>DRAINAGE</b> (D)	
<b>VOLTS</b>	<b>KW</b>	<b>3PH AMPS</b>	1 1/2" Dia. Do not connect other units to this drain. Drain line must be vented. No PVC pipe for drain.
208	16.5	46	
220	15	40	
240	18	44	
440	15	20	
480	18	22	<b>CLEARANCE</b>
			Right - 6.00" Left - 3.00" Rear - 3.00"

### WATER QUALITY REQUIREMENT

The quality of water varies greatly from region to region. Steam equipment must be blown down daily and chemically descaled periodically to ensure proper operation. To minimize service problems caused by the accumulation of minerals and chemicals in water, review the following quality guidelines with a local water treatment specialist. Inlet water that is beyond these specified guidelines should be treated to achieve the acceptable limits.

TOTAL DISSOLVED SOLIDS	less than 60 parts per million
TOTAL ALKALINITY	less than 20 parts per million
SILICA	less than 13 parts per million
pH FACTOR	greater than 7.5
CHLORINE	less than 30 parts per million

A typical water quality analysis can be secured from your local water district. Water that is potable does not guarantee compatibility with steam equipment. Try **SteamerGard** for factory authorized water.

Cleveland Range reserves right of design improvement or modification, as warranted.

CLEVELAND RANGE 24CEA10  
SEQUENCE OF OPERATIONS  
Mechanical Timer

1. Supply power is sent to the primary of the main transformer.
  - 115 VAC is sent from the secondary of the main transformer to the on/off rocker,
2. To turn the unit on, depress the red on/off rocker switch.
  - 115 VAC is sent to the red indicator light.
  - 115 VAC is sent to both coils of the normally open drain valves closing them.
  - 115 VAC is sent to the H and N terminals of both water level boards.
3. With the water level board energized and no water in the generators
  - After a 5 second delay, 115 VAC is sent from the FILL terminals to the fill solenoids.
  - The fill solenoids open and the generators fill through the drain valves until the high probe is grounded (see step 4).
  - The water fills to the low probe in each probe assembly shorting it to ground
  - 115 VAC is sent from the HEAT terminals of the water level board to the timed manual switches.
  - 115 VAC is sent to the heat standby timer which will energize the R2 relay coil 3 seconds every 4 minutes
  - The normally open contacts of the R2 relay close bypassing the timed/manual switch to maintain heat while unit is idle
4. For each compartment, when the timed/manual switch is in the manual position or timed position with time on the timer
  - 115 VAC is sent from the timer to the coil of the R5 relay for the top compartment
    - The R5 relay energizes
    - R5B contacts close sending 115 VAC to the motor timer
    - R5A contacts close sending 115 VAC through the optional door switch to the normally closed contacts of the high limits
  - 115 VAC is then sent through the high limits to the coil of condensate solenoid and the coil of the contactor.
  - 115 VAC is sent to the clean light timer.
    - When the clean light timer times down 115 VAC is sent to the clean light switch.
    - When the clean light switch is depressed the timer is reset.
    - When the contactor is energized supply voltage is sent to both of the elements.
  - 115 VAC is sent from the timer to the coil of the R6 relay for the bottom compartment
    - The R6 relay energizes
    - R6B contacts close sending 115 VAC to the motor timer
    - R6A contacts close sending 115 VAC through the optional door switch to the normally closed contacts of the high limits
  - 115 VAC is then sent through the high limits to the coil of condensate solenoid and the coil of the contactor.

- 115 VAC is sent to the clean light timer.
  - When the clean light timer times down 115 VAC is sent to the clean light switch.
  - When the clean light switch is depressed the timer is reset.
  - When the contactor is energized supply voltage is sent to both of the elements.
  - When the mechanical timer times out 115 VAC is sent to the 3-second timer and then to the buzzer for 3 seconds.
  
- 5. When the water level reaches the high probe then 115 VAC is removed from the FILL terminal and the fill solenoid is turned off.
  
- 6. After the water level drops below the high probe for 5 seconds 115 VAC is sent to the FILL terminal again.
  
- 7. The red 115 VAC switch is depressed and the unit is turned off.
  - 115 VAC is removed from the timer and heat circuits.
  - 115 VAC is removed from the normally open drain valves allowing the steamer to drain.
  - 115 VAC is sent to the 3-minute timer and the R1 relay coil is energized.
  - The normally open contacts of the R1 relay will close
  - The fill solenoids are then energized for 3 minutes flushing the drains.

# STEAMCRAFT-10 ELECTRIC MECHANICAL TIMER

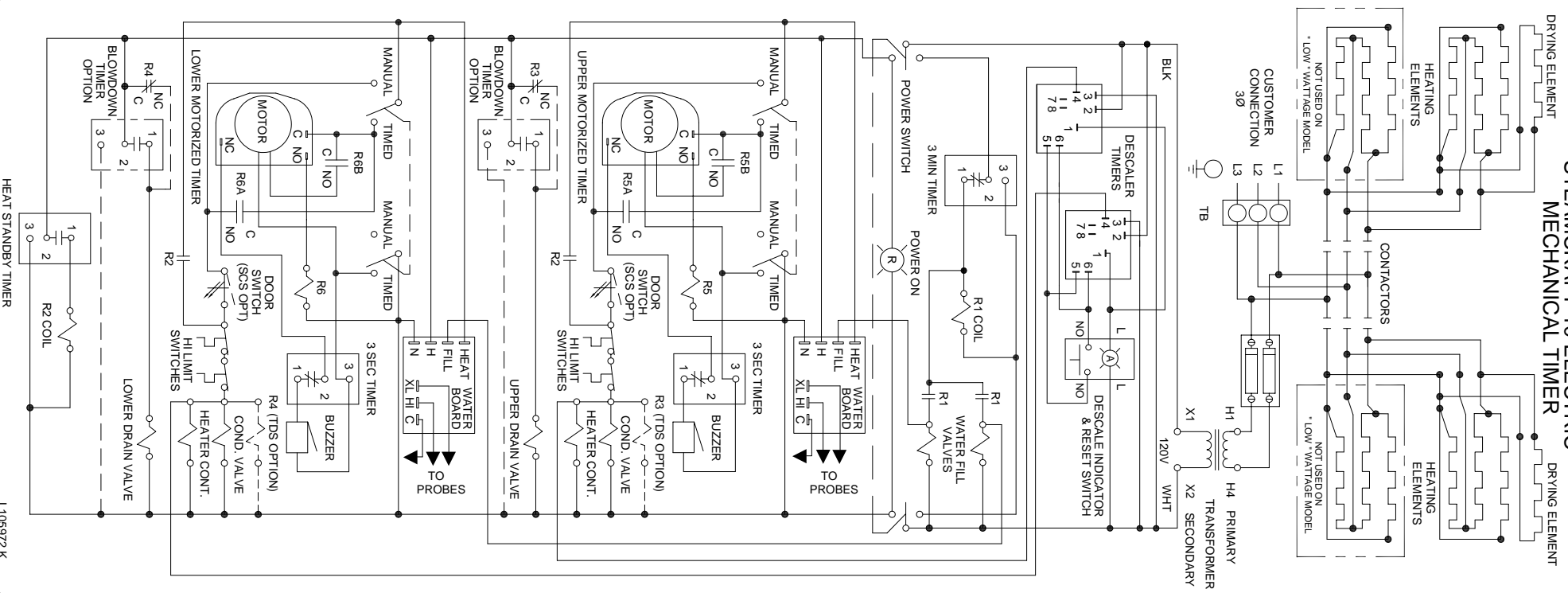

HEAT STANDBY TIMER

L105972K

# STEAMCRAFT 10 - ELECTRIC MECHANICAL TIMER

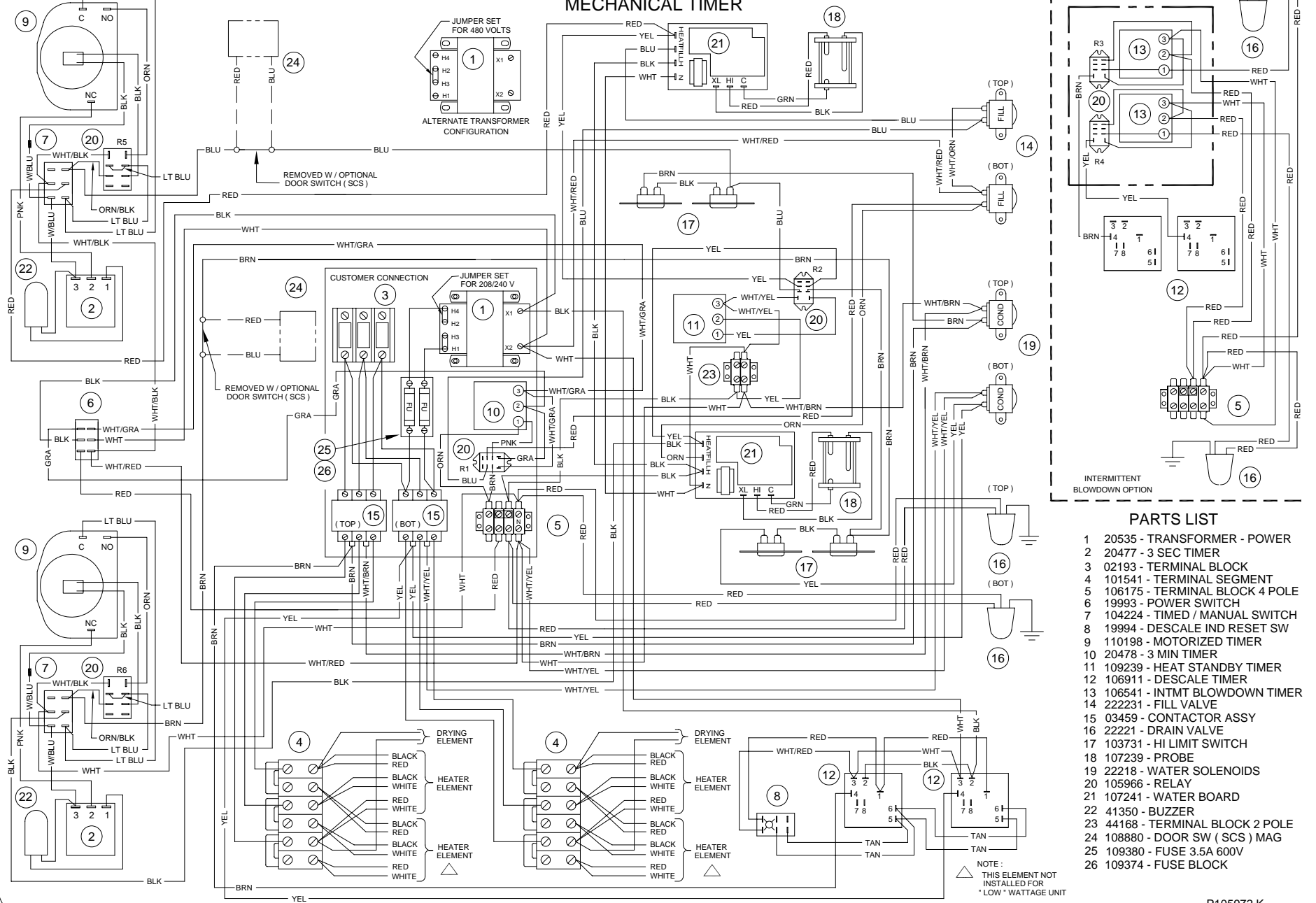

## PARTS LIST

- 1 20535 - TRANSFORMER - POWER
- 2 20477 - 3 SEC TIMER
- 3 02193 - TERMINAL BLOCK
- 4 101541 - TERMINAL SEGMENT
- 5 106175 - TERMINAL BLOCK 4 POLE
- 6 19993 - POWER SWITCH
- 7 104224 - TIMED / MANUAL SWITCH
- 8 19994 - DESCALE IND RESET SW
- 9 110198 - MOTORIZED TIMER
- 10 20478 - 3 MIN TIMER
- 11 109239 - HEAT STANDBY TIMER
- 12 106911 - DESCALE TIMER
- 13 106541 - INTMT BLOWDOWN TIMER
- 14 222231 - FILL VALVE
- 15 03459 - CONTACTOR ASSY
- 16 22221 - DRAIN VALVE
- 17 103731 - HI LIMIT SWITCH
- 18 107239 - PROBE
- 19 22218 - WATER SOLENOIDS
- 20 105966 - RELAY
- 21 107241 - WATER BOARD
- 22 41350 - BUZZER
- 23 44168 - TERMINAL BLOCK 2 POLE
- 24 108880 - DOOR SW ( SCS ) MAG
- 25 109380 - FUSE 3.5A 600V
- 26 109374 - FUSE BLOCK

NOTE:  
THIS ELEMENT NOT  
INSTALLED FOR  
"LOW" WATTAGE UNIT

**CLEVELAND RANGE 24CEA10  
SEQUENCE OF OPERATIONS  
Electronic Timer**

1. Supply power is sent to the primary of the main transformer.
  - 115 VAC is sent from the secondary of the main transformer to the on/off rocker,
2. To turn the unit on, depress the red on/off rocker switch.
  - 115 VAC is sent to the red indicator light.
  - 115 VAC is sent to normally open drain valves closing them.
  - 115 VAC is sent to the H and N terminals of both water level boards
  - 115 VAC is sent to both 24VAC transformers for the electronic timers.
  - “PAUS” and the set time are displayed on the timer.
  - 115 VAC is sent to the normally open compartment thermostat switches.
3. With the water level board energized and no water in the generator
  - After a 5 second delay 115 VAC is sent from the FILL terminals on the water boards to the fill solenoids.
  - The fill solenoids open and the generators fill through the drain valves until the high probe is grounded (see step 4).
  - The water fills to the low probe of each probe assembly shorting it to ground
  - 115 VAC is sent from the HEAT terminals of the water boards to the timed manual switches.
  - 115 VAC is sent to the heat standby timer, which will energize the R2 relay 3 seconds every 4 minutes.
  - The normally open contacts of the R2 relay will close to maintain heat while unit is idle
4. For each compartment, when the timed/manual switch is in the timed position and time is on the timer
  - 115 VAC is sent from the timer through the door switch to the normally closed contacts of the high limits
  - 115 VAC is then sent through the high limits to the coil of condensate solenoid and the coil of the contactor.
  - 115 VAC is sent to the clean light timer.
  - When the clean light timer times down 115 VAC is sent to the clean light switch.
  - When the clean light switch is depressed the timer is reset.
  - When the contactor is energized supply voltage is sent to both of the elements.
    - Steam is energized and sent to the cooking compartment.
    - When the cooking compartment reaches 193 degrees the compartment thermostat closes sending 115 VAC to the timer.
    - The timer will stop flashing “PAUS” then begin counting down.
    - When the timer times down a buzzer will sound and the timer will open removing 115 VAC from the heat circuit.

5. When the water level reaches the high probe then 115 VAC is removed from the FILL terminal and the fill solenoid is turned off.
6. After the water level drops below the high probe for 5 seconds 115 VAC is sent to the FILL terminal again.
7. The red 115 VAC switch is depressed and the unit is turned off.
  - 115 VAC is removed from the timer and heat circuit.
  - 115 VAC is removed from the normally open drain valves allowing the steamer to drain.
  - 115 VAC is sent to the 3-minute timer and the coil of the R1 relay is energized for 3 minutes.
  - The normally open contacts of the R1 relay close
  - The fill solenoids are energized for 3 minutes flushing the drain.



# STEAMCRAFT-10 ELECTRIC ELECTRONIC TIMER

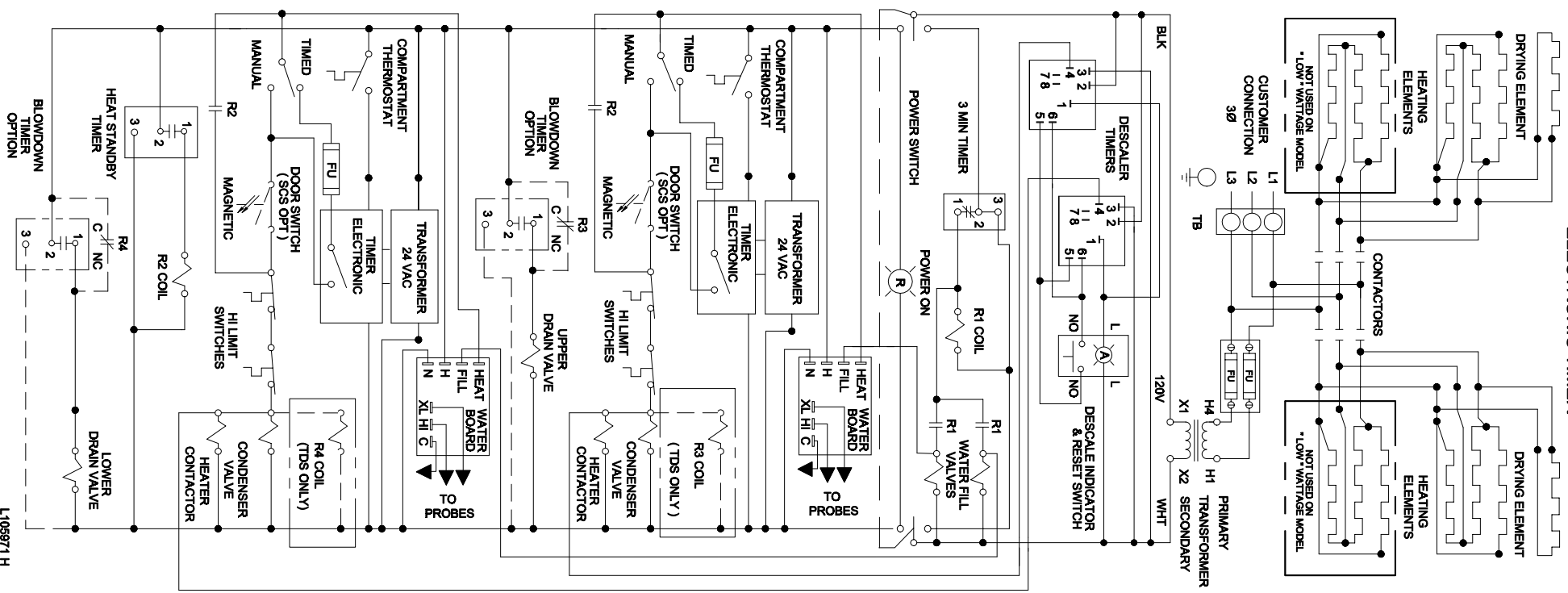

L105971 H

# STEAMCRAFT 10 - ELECTRIC ELECTRONIC TIMER

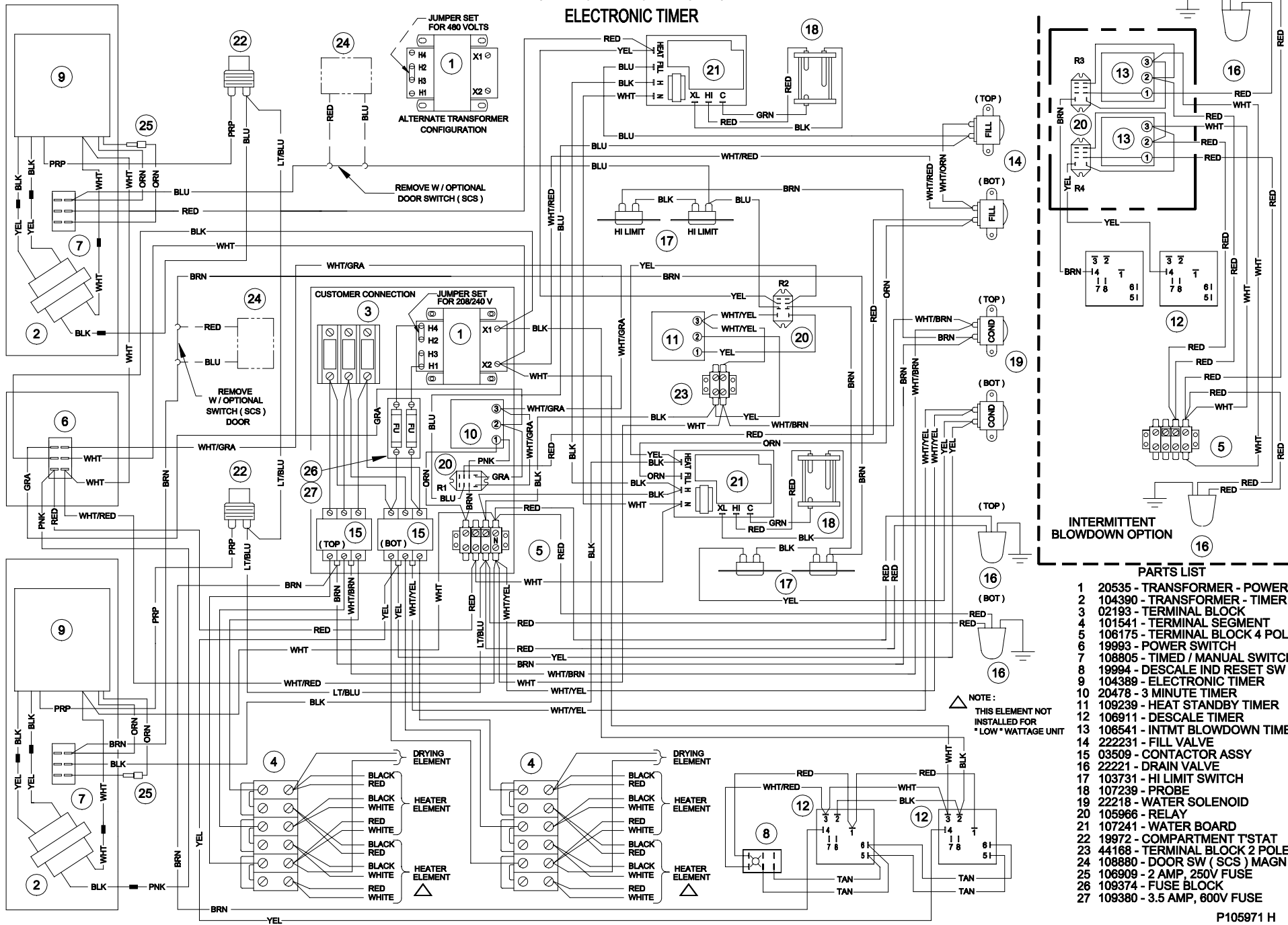

- PARTS LIST**
- 1 20535 - TRANSFORMER - POWER
  - 2 104390 - TRANSFORMER - TIMER
  - 3 02193 - TERMINAL BLOCK
  - 4 101541 - TERMINAL SEGMENT
  - 5 106175 - TERMINAL BLOCK 4 POLE
  - 6 19993 - POWER SWITCH
  - 7 108805 - TIMED / MANUAL SWITCH
  - 8 19994 - DESCALE IND RESET SW
  - 9 104389 - ELECTRONIC TIMER
  - 10 20478 - 3 MINUTE TIMER
  - 11 109239 - HEAT STANDBY TIMER
  - 12 106911 - DESCALE TIMER
  - 13 106541 - INTMT BLOWDOWN TIMER
  - 14 222231 - FILL VALVE
  - 15 03509 - CONTACTOR ASSY
  - 16 22221 - DRAIN VALVE
  - 17 103731 - HI LIMIT SWITCH
  - 18 107239 - PROBE
  - 19 22218 - WATER SOLENOID
  - 20 105966 - RELAY
  - 21 107241 - WATER BOARD
  - 22 19972 - COMPARTMENT T'STAT
  - 23 44168 - TERMINAL BLOCK 2 POLE
  - 24 108880 - DOOR SW ( SCS ) MAGN
  - 25 106909 - 2 AMP, 250V FUSE
  - 26 109374 - FUSE BLOCK
  - 27 109380 - 3.5 AMP, 600V FUSE

**PROBLEM:**  
**21CET8**  
**21CET16**  
**21CEA10**  
**Steamer won't steam.**

**Steamer won't steam**

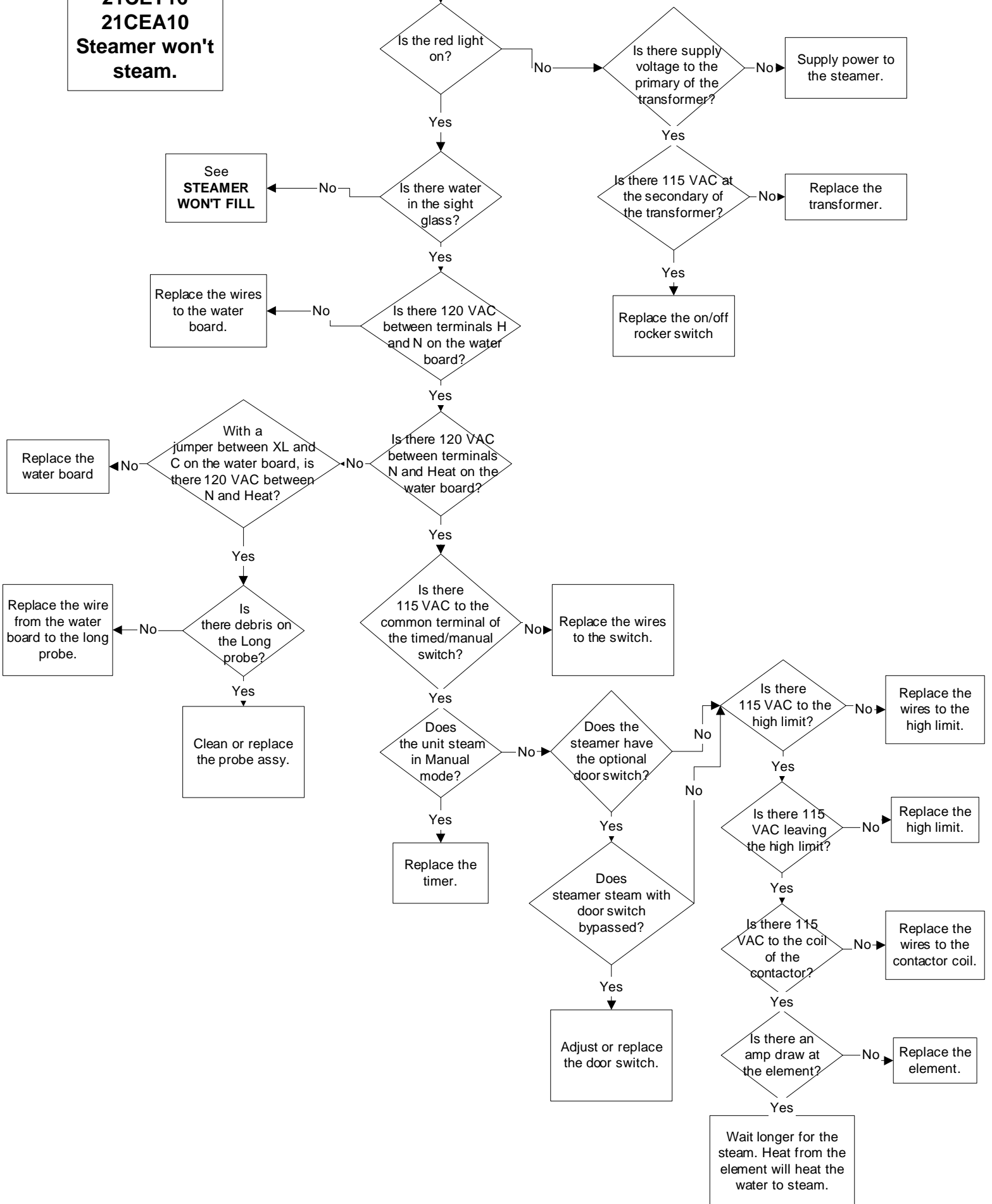

**PROBLEM:**  
**21CET8**  
**21CET16**  
**24CEA10**  
**Steamer wont fill**

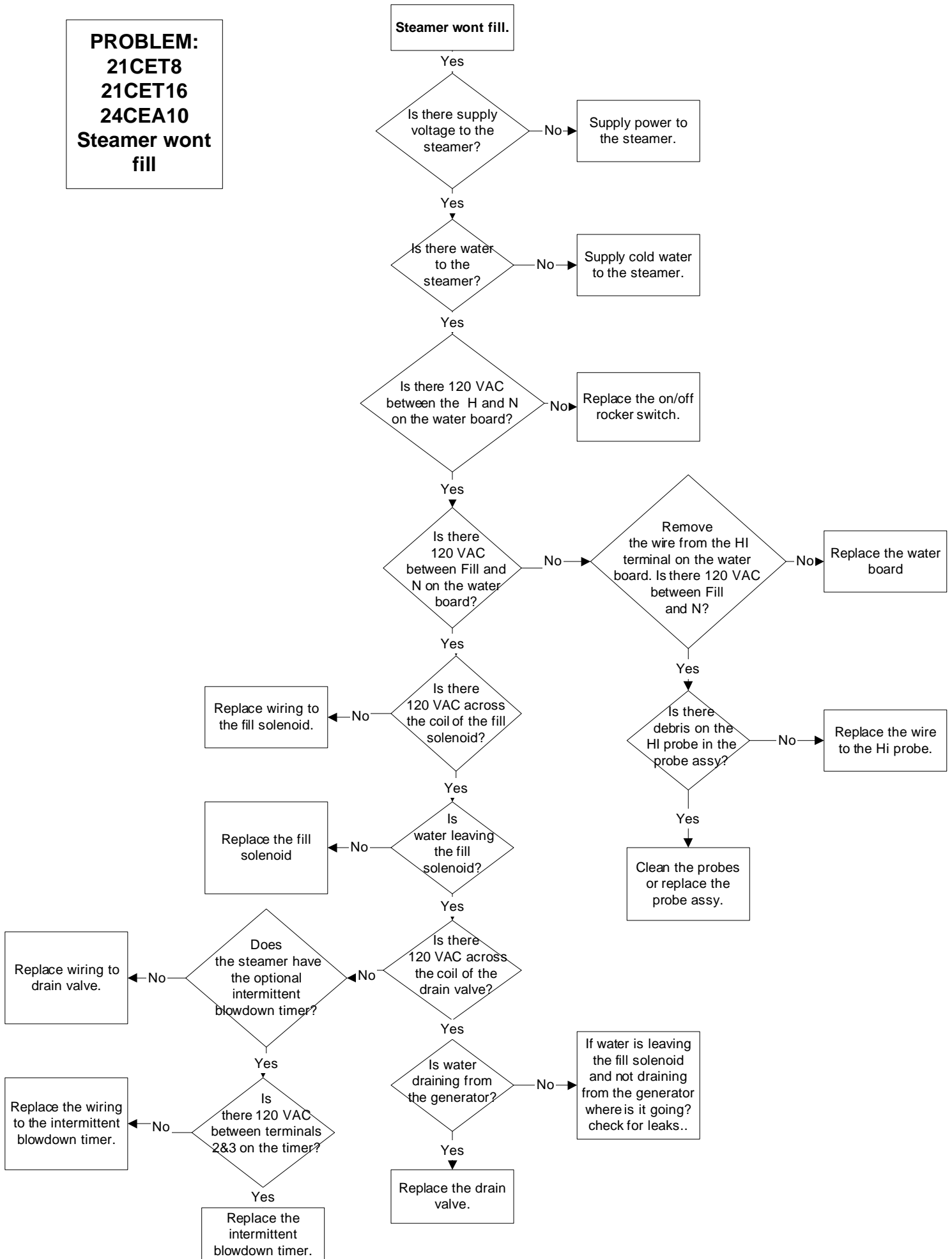

**PROBLEM:**  
**21CET8, 21CET16, 24CEA10**  
**Electronic timer displays "PAUS" and won't count down**

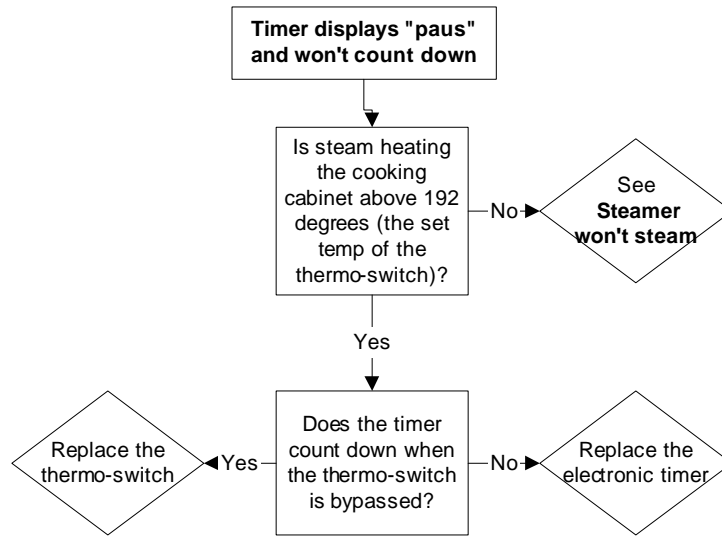

**PROBLEM:**  
**21CET8, 21CET16, 24CEA10**  
**Steam leaks around the door.**

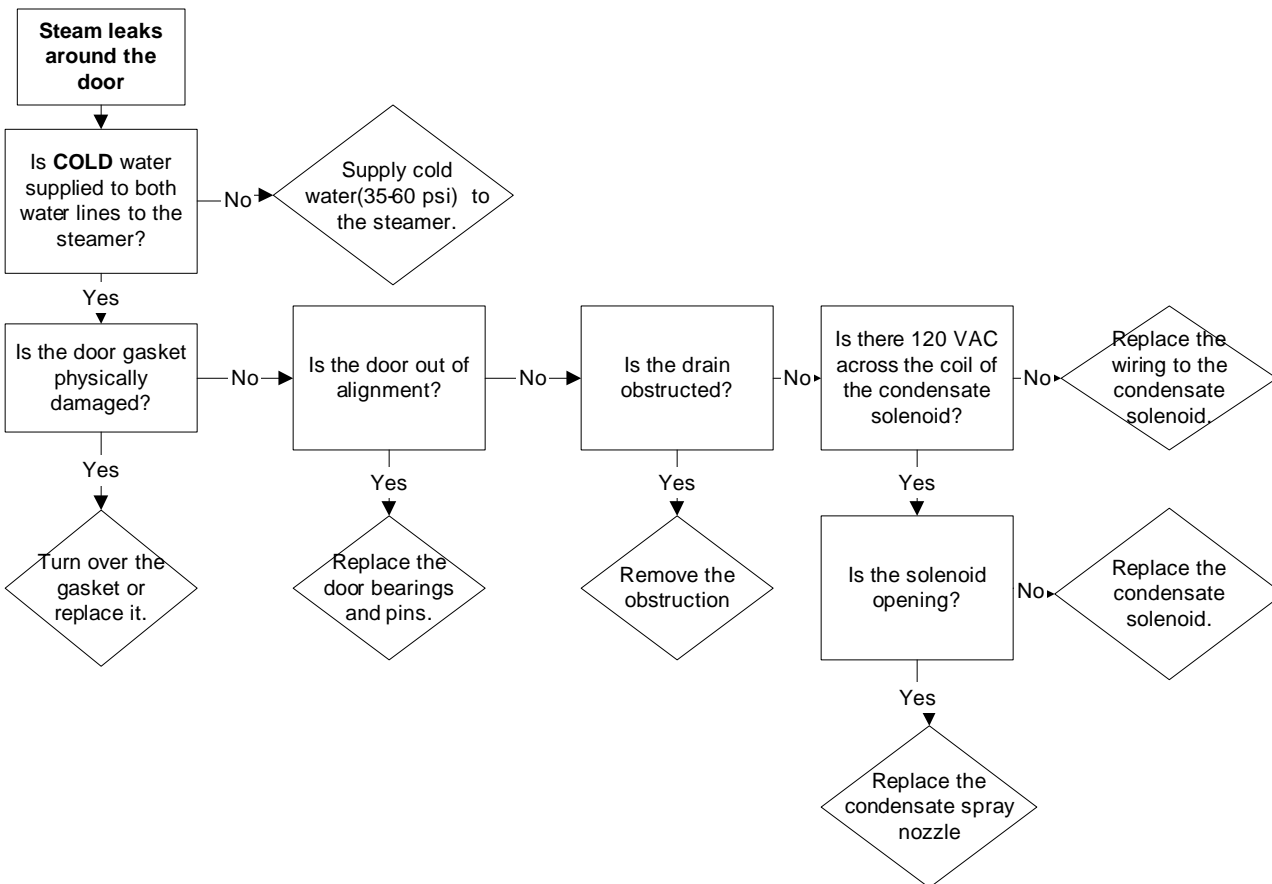

**PROBLEM:  
21CET8  
21CET16  
24CEA10  
Steamer overfills.  
(Water sprays into cooking cabinet)**

**Steamer overfills  
(Water sprays into the cooking cabinet)**

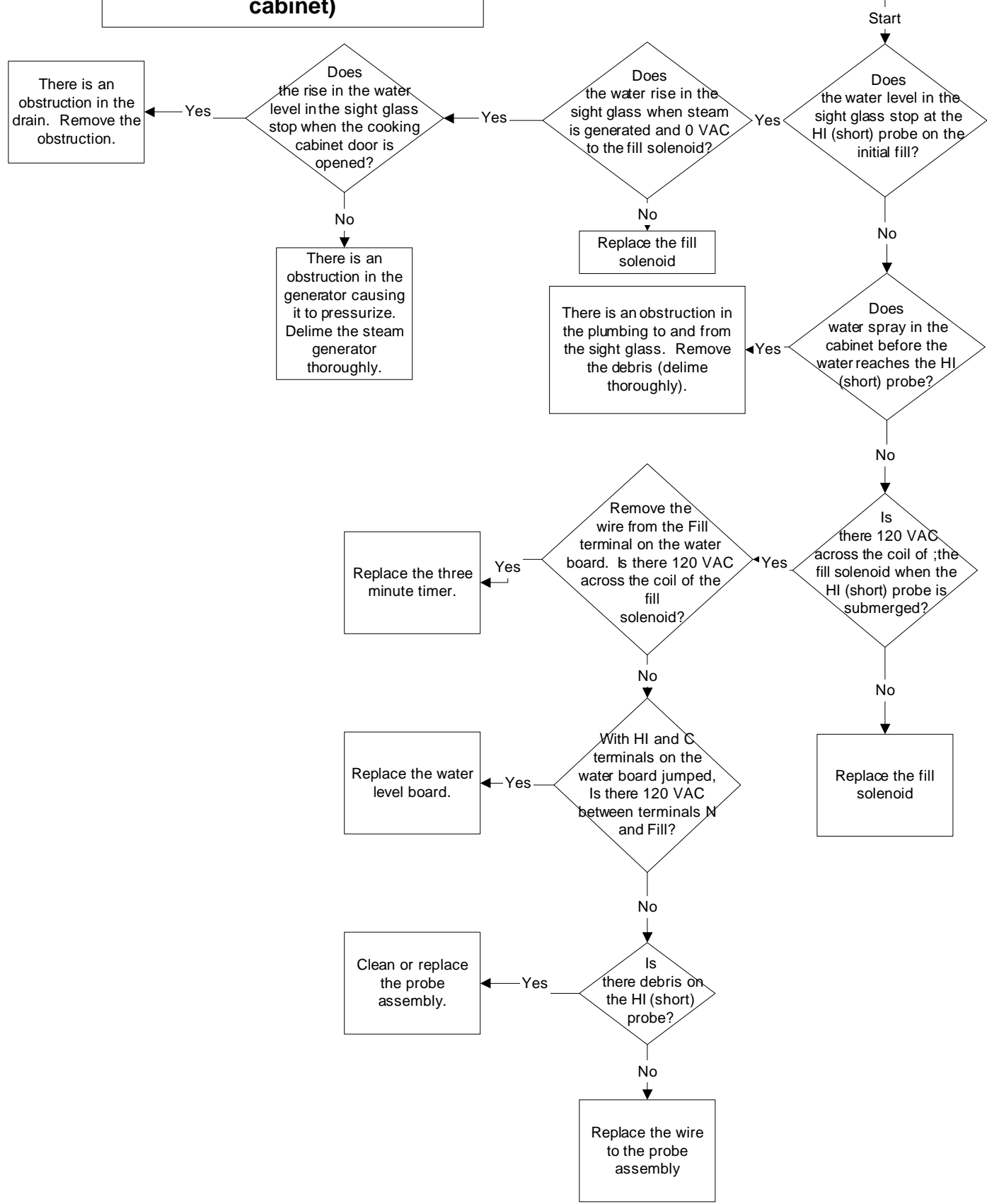

**PROBLEM:  
21CET8  
21CET16  
24CEA10  
Steamer won't stop steaming with  
door open**

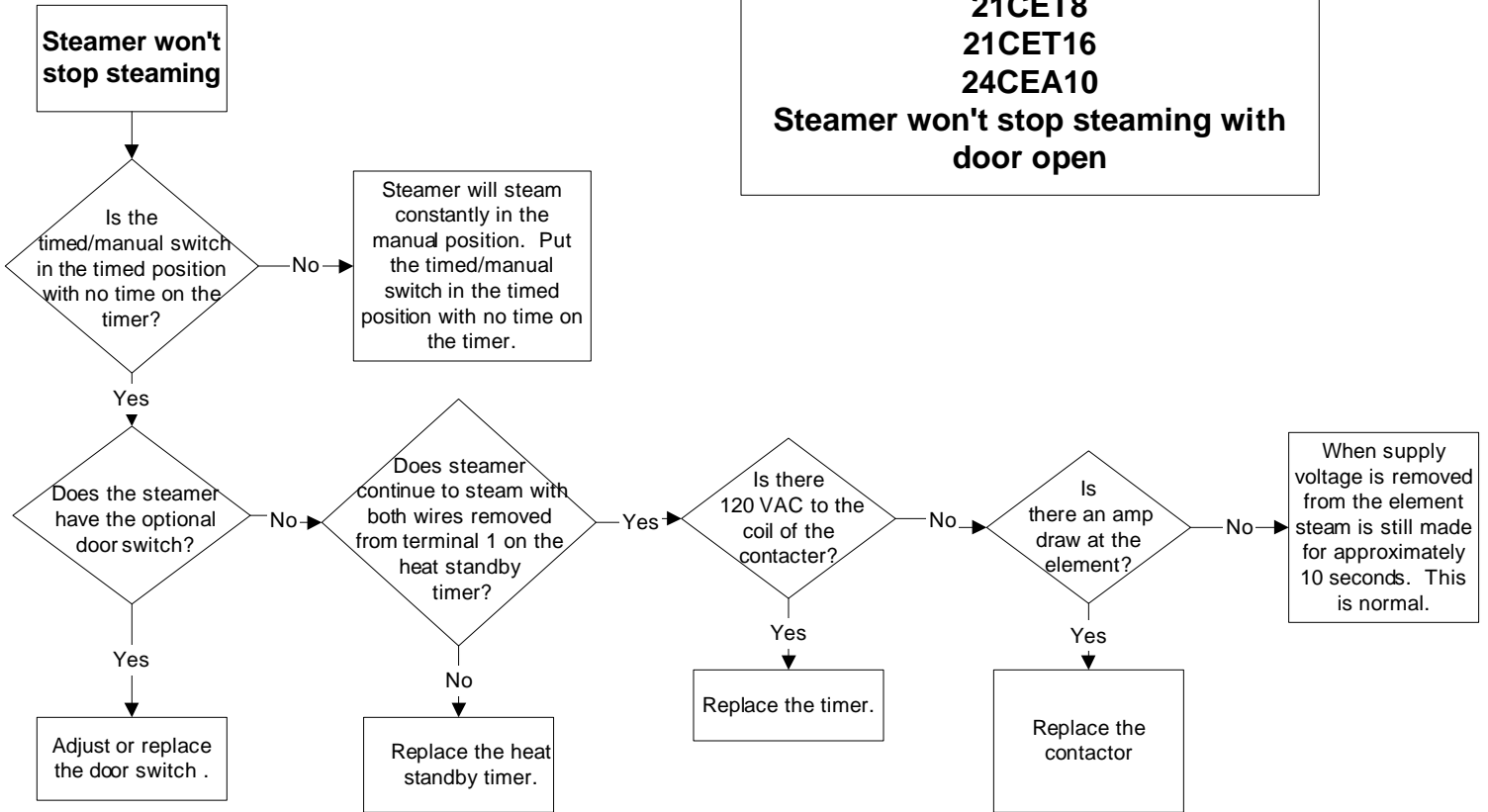

**Problem:  
21CET8, 24CEA10  
Steamer won't preheat**

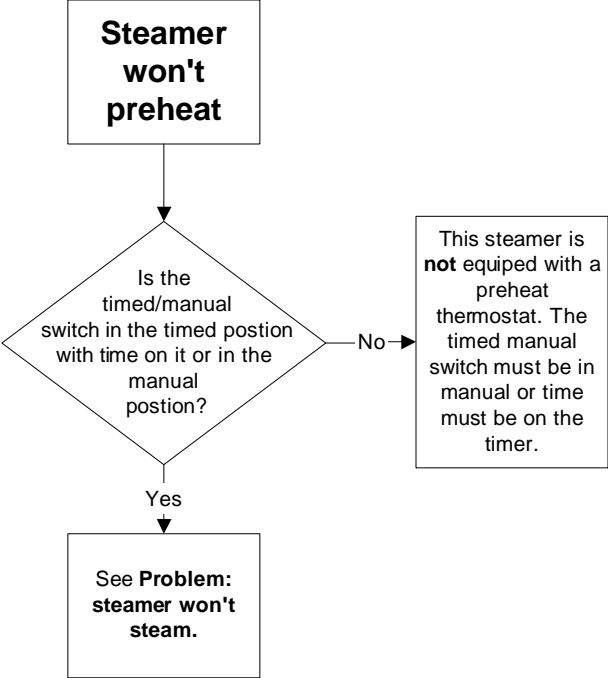



# Cleveland

## Descaling Procedure-SteamCraft Ultra and Gemini Series

### How Much DISSOLVE to Use

Model	Dissolve
Ultra 3	1/2 Gallon
Ultra 5	1 Gallon
Ultra 10 (Elec.)	1 Gallon (ea.)
Ultra 10 (Gas)	1½ Gallon
Gemini 6 & 10	1 Gallon (ea.)

#### 1. Turn the unit OFF and open the doors:

This will drain and rinse the generator for about 3 minutes.

#### 2. Turn the unit power back On:

The generator will begin to refill with water.

#### 3. Select Timed with the Timed/Manual switch:

DO NOT start the timer, since you do not want to heat the water during descaling. Leave the doors open.

#### 4. Remove descaling port cap and add with the specified amount of DISSOLVE: (See chart above)

Do this while the unit is refilling. The generators can take-up to 8 minutes to refill.

#### 5. After refill has stopped, add extra tap water into the descaling port until liquid is seen entering the cooking cabinet. Note: Ultra 10 gas will have liquid coming out of the drain,

Adding extra water when descaling will raise the descaling solution higher than the normal fill level, allowing the DISSOLVE to work on sensors and surfaces above the water line

Note: Some SteamCraft Ultra models (the electric powered Ultra 10 and Gemini 6 and 10, for example) have two generators and two descaling ports. Both units should be descaled at the same time, using this procedure

#### 6. Let the descaler soak in generator for approximately one hour:

#### 7. After one hour, turn the unit power Off: This will drain and rinse the generator for about 3 minutes.



#### 8. After the 3-minute drain cycle completes, turn the unit back ON. After the filling has stopped, add water until liquid enters the cooking compartment (or drain for the ultra 10 gas), and then turn the unit OFF. This will drain and flush any residue from the water level control assembly. Replace descaling cap.

#### 9. After the 3 minute drain cycle completes, Turn the unit ON and set the Timer for 20 minutes: Make sure the Time/Manual switch is in the timed setting and the doors are closed.

#### 10. When the timer times out (after 20 minutes) turn the power Off:

This will drain and rinse the generator for about 3 minutes.

This ends the descaling procedure. You can now turn the unit back on and resume normal startup and cooking operations.