

NOTES:

- 1.) SEE DRAWING 106131 FOR HOSE DETAIL.
- 2.) SEE INSTRUCTION DRAWING 106140 FOR LABELS AND LABEL LOCATIONS.
- 3.) REVISION SYMBOLS (Δ) ARE PLACED NEXT TO AFFECTED ITEM NO. IN BILL OF MATERIALS ONLY.
- 4.) FOR STEAM CUT-OFF SWITCH OPTION SEE DRAWING 106586 FOR LOCATION OF HOLES IN FACEPLATE AND DRAWING 106555 FOR PICTORIAL WIRING INFO.

**TABLE 1
STEAM SHUT-OFF OPTION**

ITEM NO.	QUANTITY
105449 SCREW	41
105442 GUARD	40
104196 SWITCH	39
106582 DOOR	14
104202 DOOR	13
104208 DOOR	12

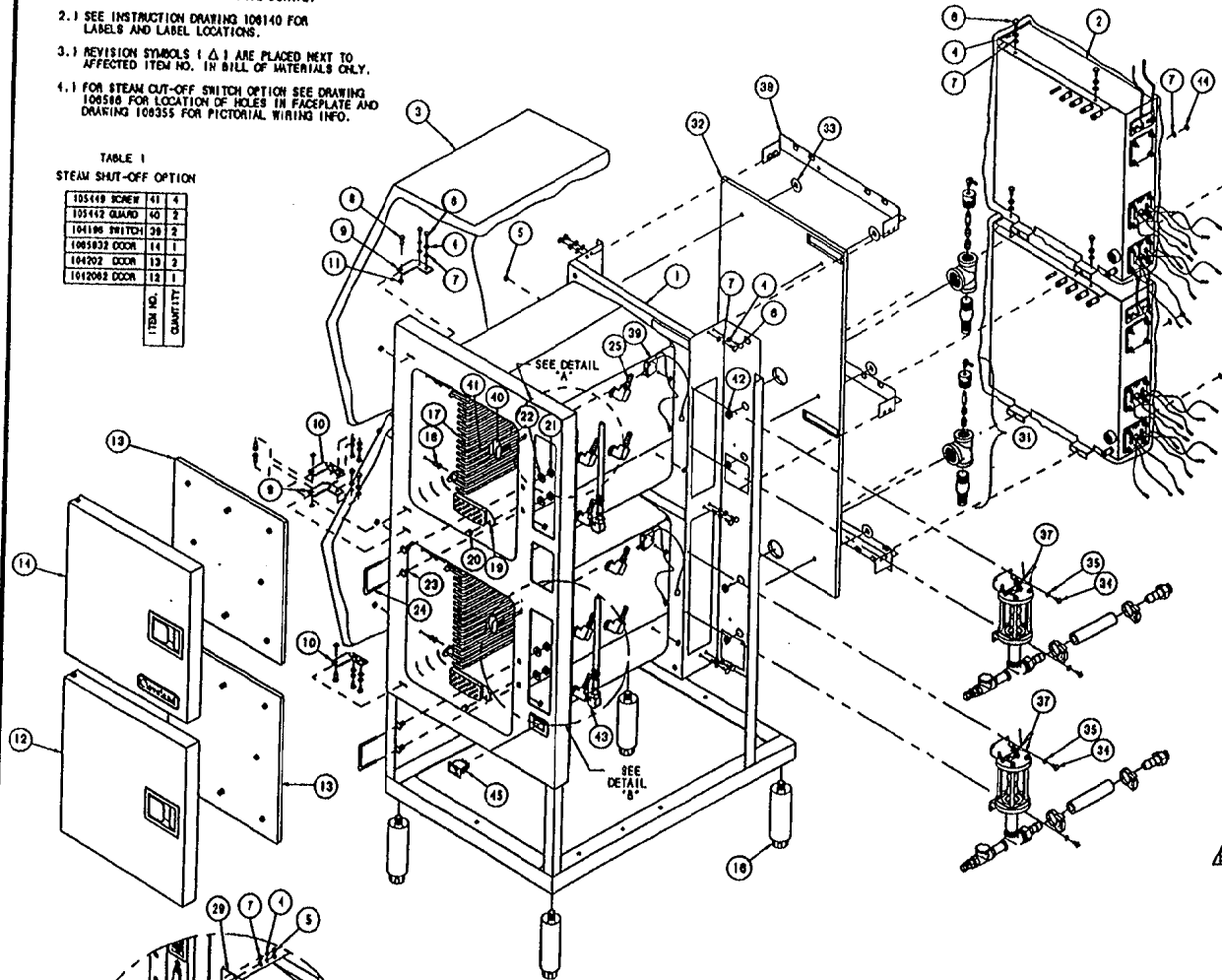

TIMER OPTIONS - DETAIL A

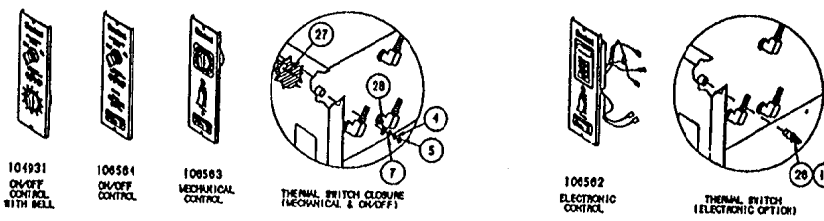

THIS DESIGN DESCRIBES A PROPRIETARY ITEM AND IS THE PROPERTY OF CLEVELAND RANGE. THIS DRAWING IS NOT TO BE COPIED OR USED WITHOUT THE APPROVAL OF CLEVELAND RANGE.

LET.	REVISIONS	DATE	BY
A	SEE EO KC-2420	05-14-93	PJD
B	SEE EO KC-2421	06-01-93	PJD
C	SEE EO KC-2422 #2	09-30-93	PJD
D	SEE EO KC-2441 #1	11-05-93	PJD
E	SEE EO KC-2601	12-01-94	PJD

ITEM	QTY.	PART NO.	DESCRIPTION
45	1	19994	SWITCH, ROCKER, SPST (CLEAN LIGHT)
44	4	14892	NUT, HEX 10-24 ELASTIC LOCK
43	2	1070591	BREATHER/SPRAY NOZZLE ASSY, 1 1/2" HOSE
42	4	02800	BUSHING, HEYCO
41	-	105449	SCREW, TRUSS HD, 6-32 X .312, S/S
40	-	105442	GUARD, SWITCH PROTECTION
39	-	104196	SWITCH ASSY, CMT, STEAM SHUT-OFF
38	3	105855	ANGLE ASSY., GENERATOR SUPPORT
37	2	106539	FLOAT & DESCALER ASSY, SC 10
-	-	108188	WIRE HARNESS, ON/OFF W/BELL, SC 10
-	-	108188	WIRE HARNESS, ON/OFF, SC 10
-	-	108188	WIRE HARNESS, MECH. CONTROL, SC 10
-	-	108187	WIRE HARNESS, ELECT. CONTROL, SC 10
35	4	101855	WASHER, FLAT #10 8/8
34	4	104123	SCREW, TORX/SLOF 10-32 X 1/2
33	6	101953	CLIP, INSULATION RETAINER
32	1	108235	INSULATION, BODY REAR
31	2	1081711	DRAIN ASSEMBLY, SC 10
-	-	104931	TIMER ASSY, ON/OFF W/BELL, SC 10
-	-	108564	TIMER ASSY, ON/OFF CONTROL, SC 10
-	-	108563	TIMER ASSY, MECH. CONTROL, SC 10
-	-	108582	TIMER ASSY, ELECTRIC CONTROL, SC 10
29	1	108703	PANEL ASSY., POWER SWITCH
28	2	23136	WASHER, FLAT 3/8 X 7/8 X 1/16
27	2	104409	CLOSURE, THERMAL OPENING
26	2	19972	SWITCH, THERMAL CLOSE
25	6	1082301	STEAM NOZZLE ASSY, STEAMCRAFT
24	2	104046	CATCH, DOOR
23	4	14895	NUT, DOOR CATCH MOUNTING, 8/8
22	4	23149	WASHER, NYLON, TYPE 8/8
21	4	14849	NUT, HEX 1/2-13, ZINC PLATED
20	2	14877	NUT, ACONR
19	2	89298	SCREEN, COMPARTMENT DRAIN, POLYPROP
18	16	101305	PIN, RACK
17	4	414232	RACK, PAN SLIDE, 18"
16	4	06156	LEG, BULLET
15	A/R	00834	SEALANT, RECTORSAL
-	-	1085832	DOOR, OUTER ASSY, H.L. W/LOGO, W/ACTUATOR
-	-	108583	DOOR, OUTER ASSY, H.L. W/LOGO
13	2	104292	DOOR, INNER ASSY, H.L.
12	-	1042062	DOOR, OUTER ASSY, H.L. W/ACTUATOR
-	-	104206	DOOR, OUTER ASSY, H.L.
11	4	104062	RING, SNAP, S/S
10	2	1040731	HINGE ASSY, WELD, LOWER
9	2	1040732	HINGE ASSY, WELD, UPPER
8	4	104017	PIN, HINGE
7	36	23116	WASHER, FLAT 1/4 ID X 5/8 OD, S/S
6	24	19170	SCREW, HEX HD, 1/4-20 X 5/8 S/S
5	24	14816	NUT, HEX 1/4-20 S/S
4	32	23105	WASHER, LOCK S/S 1/4 KATLINK STYLE
3	2	104193	INSULATION, BODY, CUT
2	2	104194	GENERATOR ASSY, SC 3.1/10 ELECTRIC
1	1	105881	CAVITY WELD ASSY, STEAMCRAFT 10

<p>CLEVELAND RANGE INC. 1333 East 179th St, Cleveland, Ohio 44110-2574</p>			
<p>TOLERANCES (UNLESS AS NOTED)</p> <p>DECIMAL ± N/A</p> <p>ANGULAR ± N/A</p>	<p>SCALE 1/8"</p>	<p>DRAWN BY DUTCHMAN</p>	<p>APPROVED BY</p>
<p>TITLE FINAL ASSEMBLY, H.L. STEAMCRAFT ULTRA 10, ELECTRIC</p>			
<p>CK</p>	<p>DATE 03-09-93</p>	<p>DRAWING NO. C - 106151</p>	<p>PAGE 1 OF 3 REV. E</p>

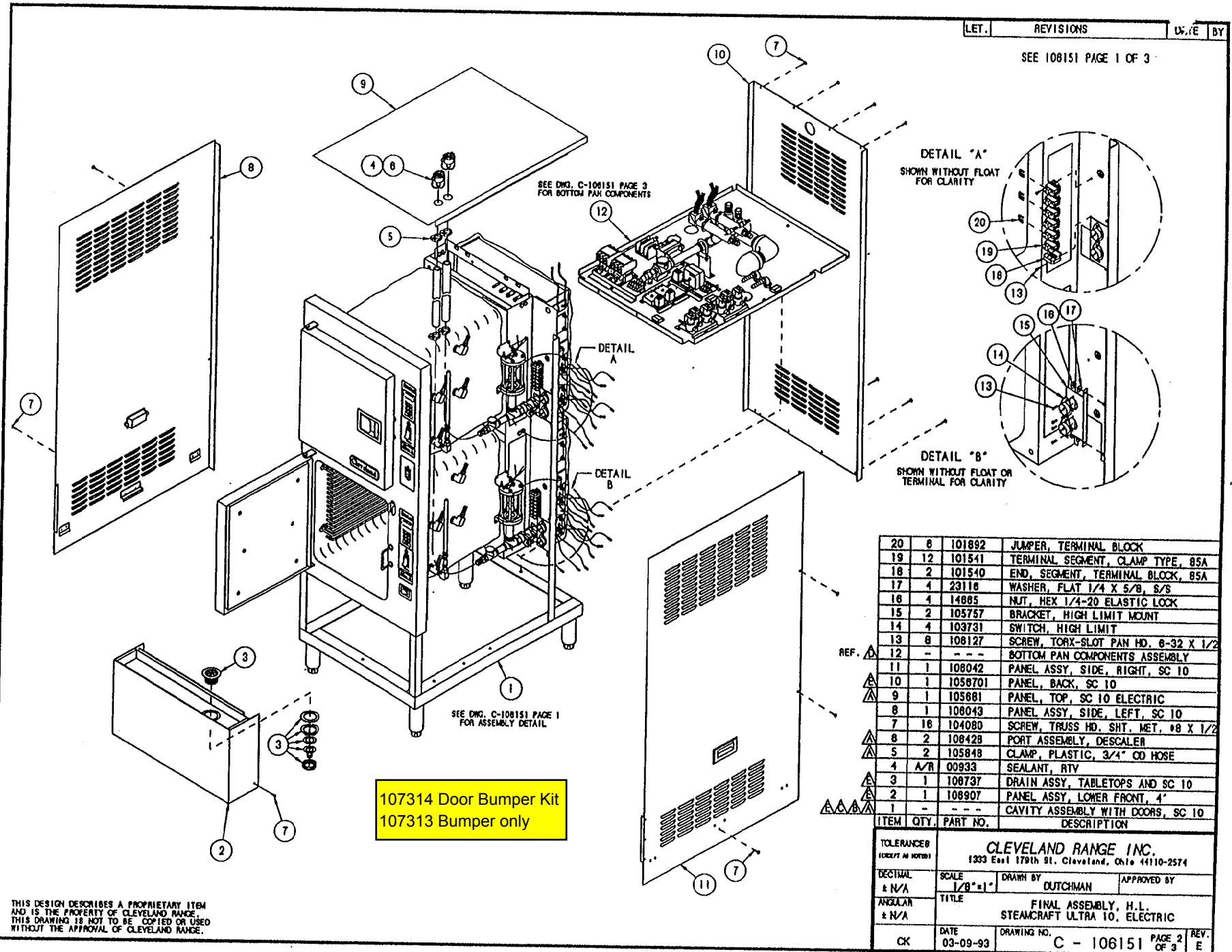

107314 Door Bumper Kit
107313 Bumper only

REF.	QTY.	PART NO.	DESCRIPTION
	20	6	101892 JUMPER, TERMINAL BLOCK
	19	12	101541 TERMINAL SEGMENT, CLAMP TYPE, 85A
	18	2	101540 END, SEGMENT, TERMINAL BLOCK, 85A
	17	4	23116 WASHER, FLAT 1/4 X 5/8, S/S
	16	4	14885 NUT, HEX 1/4-20 ELASTIC LOCK
	15	2	105757 BRACKET, HIGH LIMIT MOUNT
	14	4	103731 SWITCH, HIGH LIMIT
	13	8	108127 SCREW, TORX-SLOT PAN HD. 6-32 X 1/2
REF. Δ	12	- - -	BOTTOM PAN COMPONENTS ASSEMBLY
REF. Δ	11	1	108042 PANEL ASSY, SIDE, RIGHT, SC 10
REF. Δ	10	1	1058701 PANEL, BACK, SC 10
REF. Δ	9	1	105681 PANEL, TOP, SC 10 ELECTRIC
REF. Δ	8	1	108049 PANEL ASSY, SIDE, LEFT, SC 10
REF. Δ	7	16	104080 SCREW, TRUSS HD, SHT. MET. #8 X 1/2
REF. Δ	6	2	108428 PORT ASSEMBLY, DESCALER
REF. Δ	5	2	105848 CLAMP, PLASTIC, 3/4" OD HOSE
REF. Δ	4	A/R	00933 SEALANT, RTV
REF. Δ	3	1	108737 DRAIN ASSY, TABLETOPS AND SC 10
REF. Δ	2	1	108907 PANEL ASSY, LOWER FRONT, 4"
REF. Δ	1	- - -	CAVITY ASSEMBLY WITH DOORS, SC 10

THIS DESIGN DESCRIBES A PROPRIETARY ITEM AND IS THE PROPERTY OF CLEVELAND RANGE. THIS DRAWING IS NOT TO BE COPIED OR USED WITHOUT THE APPROVAL OF CLEVELAND RANGE.

TOLERANCES (UNLESS AS NOTED)		CLEVELAND RANGE INC. 1333 East 179th St., Cleveland, Ohio 44110-2574	
DECIMAL & N/A	SCALE 1/8"=1"	DRAWN BY DUTCHMAN	APPROVED BY
ANGULAR & N/A	TITLE	FINAL ASSEMBLY, H.L. STEAMCRAFT ULTRA 10, ELECTRIC	
CK	DATE 03-09-93	DRAWING NO. C - 108151	PAGE 2 OF 3 REV. E

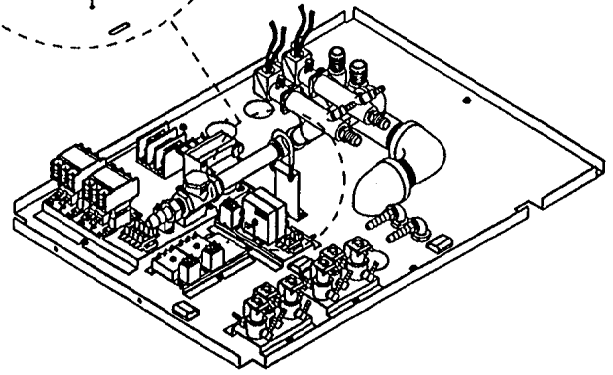
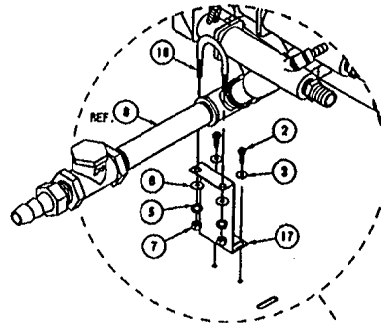
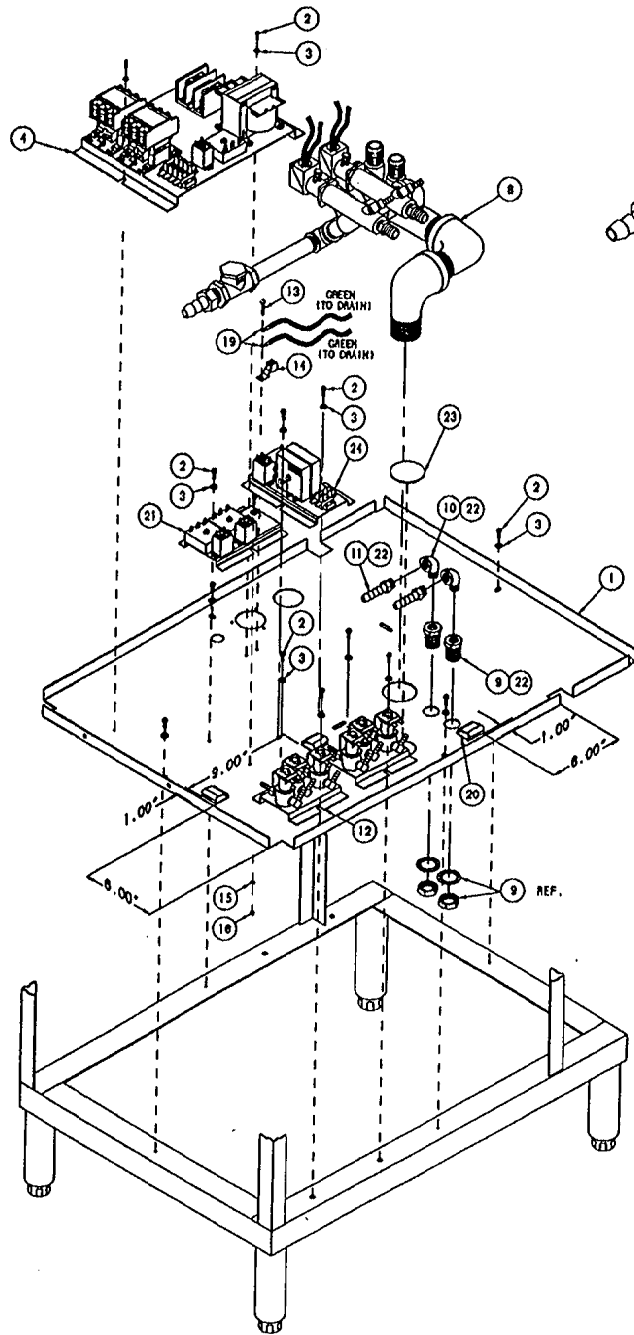

ITEM	QTY.	PART NO.	DESCRIPTION
24	1	107042	HEAT STANDBY, ULTRA 10 ELECTRIC
23	1	107083	PLUG, SNAP, STEEL, FOR 2" DIA. HOLE
22	A/R	00934	ADHESIVE, RECTORSAL
21	1	106510	INTERMITTENT BLOWDOWN ASSEMBLY (OPTION)
20	3	23432	CLIP, MOUNTING, WIRE/CABLE 1.250 X 1.500
19	2	20336	TERMINAL RING, NON-INSULATE
18	1	105970	"U" BOLT, 3/4" PIPE
17	1	105989	BRACKET, DRAIN SUPPORT, SC10 ELEC.
16	1	14859	NUT, HEX, #10-24, S/S
15	1	23114	WASHER, LOCK, INT. TOOTH #10
14	1	12331	LUG, GROUND, SOLDERLESS
13	1	19287	SCREW, PAN HEAD 10-24 X 1/2
12	2	105991	WATER INLET ASSY.
11	2	100746	FITTING, HOSE, 1/2 H X 3/8 NPT
10	2	05280	ELBOW, STREET, 3/8 X 90°, BRASS
9	2	105794	FITTING, BULKHEAD, 3/8 NPT, BRASS
8	1	105875	DRAIN MANIFOLD ASSY., SC 10, ELECTRIC
7	2	14818	NUT, HEX, 1/4-20, S/S
6	2	23116	WASHER, FLAT, 1/4, S/S
5	2	23105	WASHER, SPLIT LOCK, 1/4, S/S
4	1	105924	ELECTRIC BOX ASSY., SC 10, ELECTRIC
3	16	101855	WASHER, FLAT #10, S/S
2	18	108123	SCREW, TORX/SLOT 10-32 X 1/2
1	1	105667	PAN, BOTTOM, STEAMCRAFT 10

CAVITY WELD ASSY. (REF. 1)

THIS DESIGN DESCRIBES A PROPRIETARY ITEM AND IS THE PROPERTY OF CLEVELAND RANGE. THIS DRAWING IS NOT TO BE COPIED OR USED WITHOUT THE APPROVAL OF CLEVELAND RANGE.

TOLERANCES (EXCEPT AS NOTED)			
DECIMAL ± .030	SCALE 3/16"=1"	CLEVELAND RANGE INC. 1333 East 179th St. Cleveland, Ohio 44110-2574	
ANGULAR ± 1°	TITLE	DRAWN BY DUTCHMAN	APPROVED BY
CK	DATE 03-09-93	FINAL ASSEMBLY, H.L. STEAMCRAFT ULTRA 10, ELECTRIC	
	DRAWING NO. C - 108151	PAGE 3 OF 3	REV. E

NOTES:
1. RELATIVE POSITION OF OBJECTS ARE NOT REPRESENTATIVE OF INSTALLED LOCATIONS.

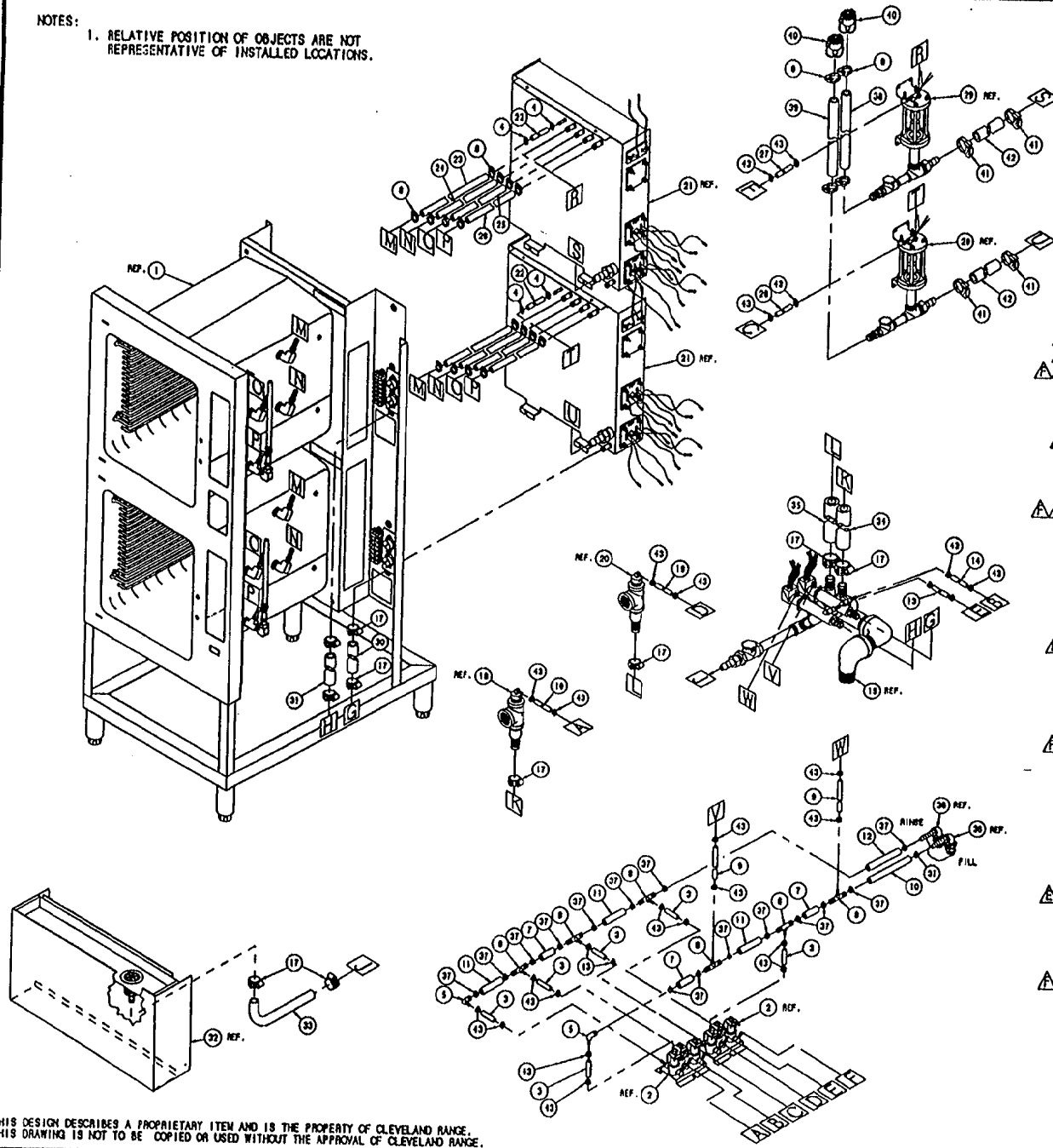

LET.	REVISIONS	L.	BY
A	SEE E.O. IC-2423	05-20-93	PJD
B	SEE E.O. IC-2431	06-02-93	PJD
C	SEE E.O. IC-2452 R2	10-01-93	PJD
D	SEE E.O. IC-2448 R1	11-05-93	PJD
E	SEE E.O. IC-2597	3-28-94	DLJ
F	SEE E.O. IC-2682	12-03-94	PJD

43	28	108528	CLAMP, HOSE, WORM DRIVE, S/S
△	42	2	1080930550 HOSE, SILICONE 1-1/8 OD X 3/4 ID X 5-1/2'
△	41	4	105847 CLAMP, PLASTIC, 1-1/8" HOSE
△	40	-	108428 PORT ASSEMBLY, DESCALER
△	39	1	1044884600 HOSE, SILICONE 1/2 ID X 3/4 OD X 48 LG
△	38	1	1044882400 HOSE, SILICONE 1/2 ID X 3/4 OD X 24 LG
△	37	18	108219 HOSE CLAMP, METAL WORM DRIVE
△	36	-	WATER SUPPLY ASSEMBLY
△	35	1	1054892950 HOSE, EPDM, BLACK, 1" X 29.500" LG.
△	34	1	1054890750 HOSE, EPDM, BLACK, 1" X 7.500" LG.
△	33	1	107010 HOSE, TRAY DRAIN, 3/4" I.D. BLACK EPDM
△	32	-	PANEL ASSY, LOWER FRONT, SC 10
△	31	1	085053600 HOSE, WHITE DARIPREEN, 3/4 X 38" LG.
△	30	1	085051450 HOSE, WHITE DARIPREEN, 3/4 X 14.500" LG
△	29	-	108540 FLOAT & DESCALER ASSEMBLY, SC 10
△	28	1	1058503000 HOSE, NT-80, 1/4 ID X 1/2 OD X 30" LG.
△	27	1	1058505200 HOSE, NT-80, 1/4 ID X 1/2 OD X 52" LG.
△	26	2	1044882700 HOSE, SILICONE, 1/2 ID X 3/4 OD X 27"
△	25	2	1044882000 HOSE, SILICONE, 1/2 ID X 3/4 OD X 20"
△	24	2	1044882200 HOSE, SILICONE, 1/2 ID X 3/4 OD X 22"
△	23	2	1044881600 HOSE, SILICONE, 1/2 ID X 3/4 OD X 16"
△	22	2	1043792200 HOSE, SILICONE, 1/4 ID X 1/2 OD X 22"
△	21	-	104194 GENERATOR ASSY.
△	20	-	COMPARTMENT DRAIN ASSY, UPPER
△	19	1	1058504800 HOSE, NT-80, 1/4 ID X 1/2 OD X 48" LG.
△	18	-	COMPARTMENT DRAIN ASSY, LOWER
△	17	10	03204 CLAMP, METAL WORM DRIVE
△	16	1	1058503300 HOSE, NT-80, 1/4 ID X 1/2 OD X 33" LG.
△	15	-	105875 DRAIN MANIFOLD ASSY, S/C 10, ELECTRIC
△	14	1	1058502300 HOSE, NT-80, 1/4 ID X 1/2 OD X 23" LG.
△	13	1	1058501550 HOSE, NT-80, 1/4 ID X 1/2 OD X 15.500" LG.
△	12	1	1058490525 HOSE, NT-80, 1/2 ID X 3/4 OD X 5.250" LG.
△	11	3	1058490325 HOSE, NT-80, 1/2 ID X 3/4 OD X 3.250" LG.
△	10	1	1058490850 HOSE, NT-80, 1/2 ID X 3/4 OD X 6.50" LG.
△	9	2	1058501500 HOSE, NT-80, 1/4 ID X 1/2 OD X 15.00" LG.
△	8	6	105790 FITTING, TEE, 1/2 H X 1/2 H X 1/4 H
△	7	3	1058490200 HOSE, NT-80, 1/2 ID X 3/4 OD X 2.00" LG.
△	6	18	105849 CLAMP, PLASTIC, 3/4" OD HOSE
△	5	2	105782 FITTING, ELBOW, 90°, 1/4 H X 1/2 H
△	4	4	104383 CLAMP, NYLON, 1/2" OD HOSE
△	3	6	1058502000 HOSE, NT-80, 1/4 ID X 1/2 OD X 2" LG.
△	2	-	105981 VALVE ASSY, WATER INLET
△	1	-	105681 CAVITY WELD ASSY, SC 10

107312

107270

THIS DESIGN DESCRIBES A PROPRIETARY ITEM AND IS THE PROPERTY OF CLEVELAND RANGE. THIS DRAWING IS NOT TO BE COPIED OR USED WITHOUT THE APPROVAL OF CLEVELAND RANGE.

ITEM	QTY.	PART NO.	DESCRIPTION																																
<table border="1"> <tr> <td colspan="4">TOLERANCES (UNLESS AS NOTED)</td> </tr> <tr> <td>DECIMAL</td> <td>SCALE</td> <td>DRAWN BY</td> <td>APPROVED BY</td> </tr> <tr> <td>± N/A</td> <td>1/8"=1</td> <td>DUTCHMAN</td> <td></td> </tr> <tr> <td colspan="4">ANGULAR</td> </tr> <tr> <td>± N/A</td> <td colspan="3">TITLE</td> </tr> <tr> <td colspan="4">HOSE DETAIL, H.L. STEAKCRAFT ULTRA 10, ELECTRIC</td> </tr> <tr> <td>DATE</td> <td colspan="2">DRAWING NO.</td> <td>REV.</td> </tr> <tr> <td>CK 10-29-92</td> <td colspan="2">C - 106131</td> <td>F</td> </tr> </table>				TOLERANCES (UNLESS AS NOTED)				DECIMAL	SCALE	DRAWN BY	APPROVED BY	± N/A	1/8"=1	DUTCHMAN		ANGULAR				± N/A	TITLE			HOSE DETAIL, H.L. STEAKCRAFT ULTRA 10, ELECTRIC				DATE	DRAWING NO.		REV.	CK 10-29-92	C - 106131		F
TOLERANCES (UNLESS AS NOTED)																																			
DECIMAL	SCALE	DRAWN BY	APPROVED BY																																
± N/A	1/8"=1	DUTCHMAN																																	
ANGULAR																																			
± N/A	TITLE																																		
HOSE DETAIL, H.L. STEAKCRAFT ULTRA 10, ELECTRIC																																			
DATE	DRAWING NO.		REV.																																
CK 10-29-92	C - 106131		F																																
<p style="text-align: center;">CLEVELAND RANGE INC. 1333 East 179th St. Cleveland, Ohio 44110-2574</p>																																			

LET.	REVISIONS	DATE	BY
------	-----------	------	----

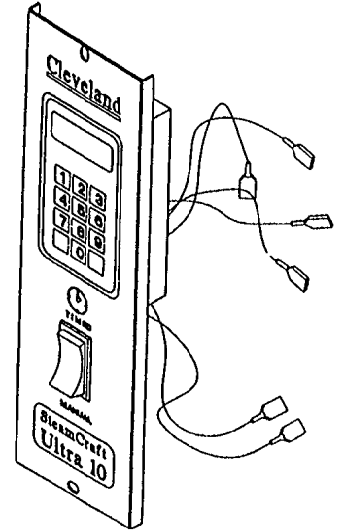
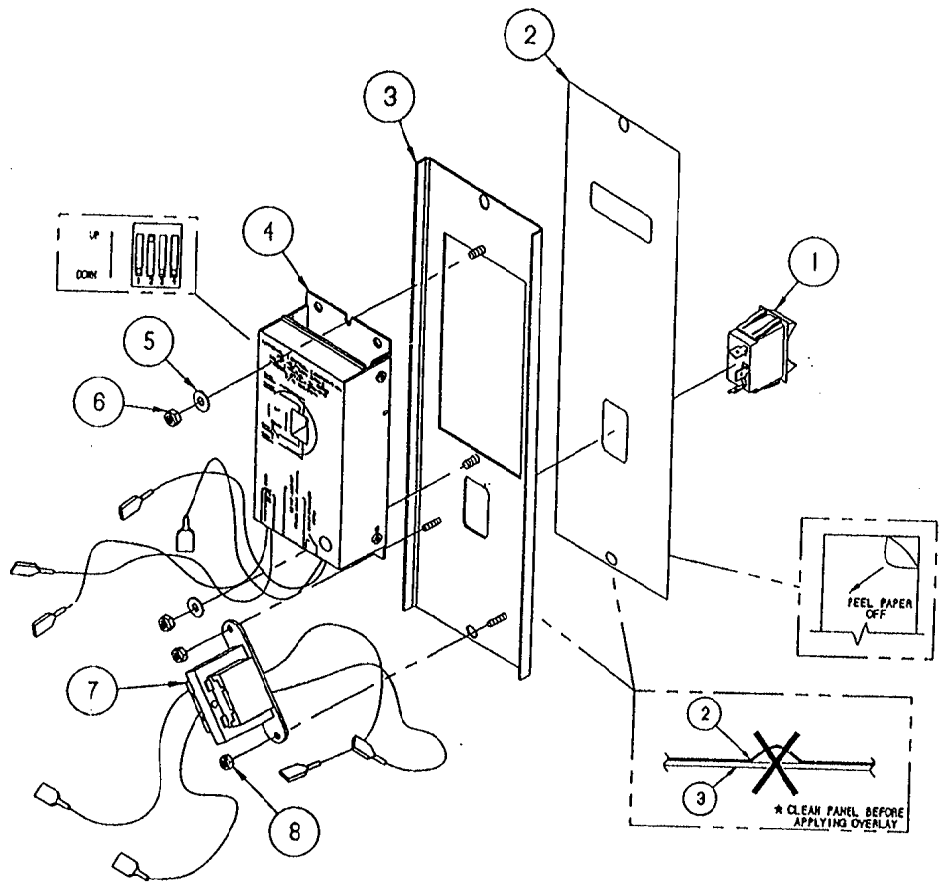

8	2	104223	NUT, HEX, #6-32, ELASTIC LOCK
7	1	104390	TRANSFORMER ASSEMBLY
6	2	14692	NUT, HEX, #10-24, ELASTIC LOCK
5	2	101855	WASHER, FLAT, #10, S/S
4	1	104389	TIMER ASSEMBLY, NCC
3	1	104704	PANEL, WELDMENT, ELEC TIMER
2	1	106454	LABEL, CONTROL PANEL, ELEC
1	1	104224	SWITCH, ROCKER, SPDT
ITEM	QTY.	PART NO.	DESCRIPTION

TOLERANCES (EXCEPT AS NOTED)			
CLEVELAND RANGE INC. 1333 East 179th St. Cleveland, Ohio 44110-2574			
DECIMAL ± N/A	SCALE 3/8=1	DRAWN BY DUTCHMAN	APPROVED BY
ANGULAR ± N/A	TITLE TIMER ASS'Y, ELECTRIC CONTROL REAR MOUNTED, STEAMCRAFT ULTRA 10		
CK	DATE 05-27-93	DRAWING NO. B - 106562	REV. -

THIS DESIGN DESCRIBES A PROPRIETARY ITEM AND IS THE PROPERTY OF CLEVELAND RANGE. THIS DRAWING IS NOT TO BE COPIED OR USED WITHOUT THE APPROVAL OF CLEVELAND RANGE.

LET. REVISIONS DATE BY

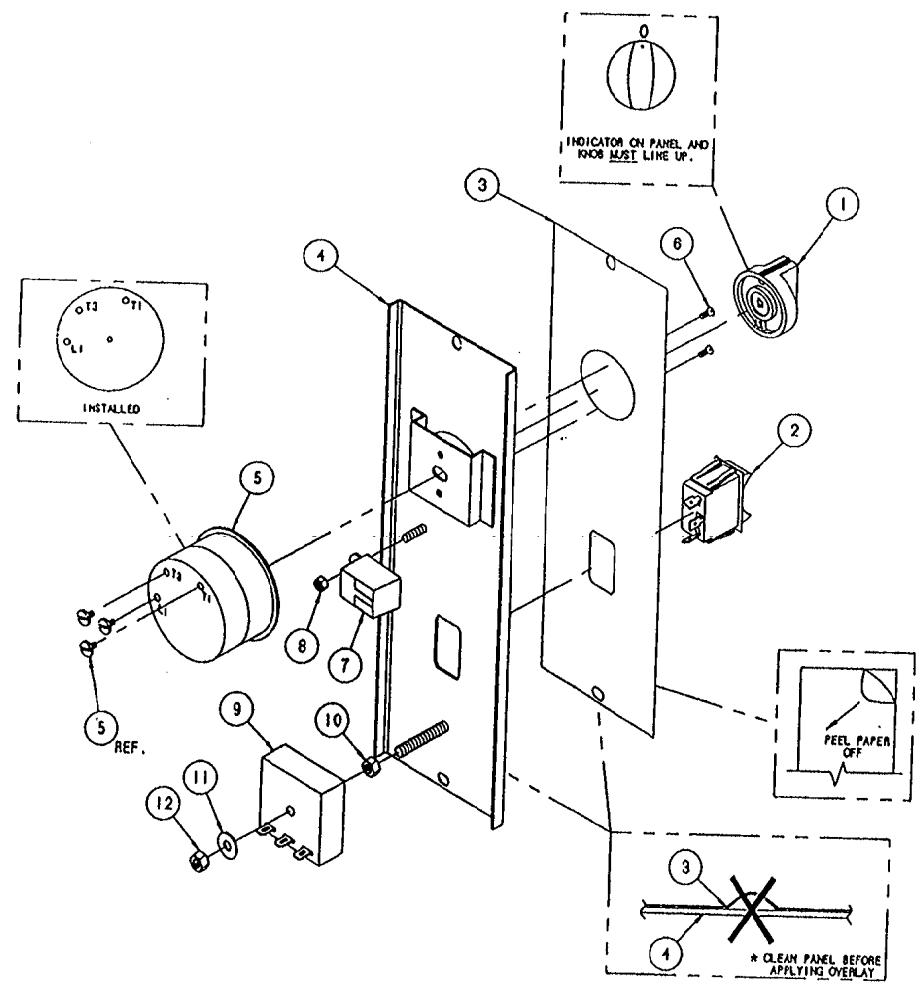
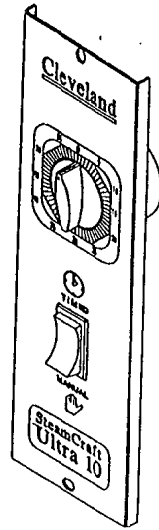

ITEM	QTY.	PART NO.	DESCRIPTION
12	1	101873	NUT, HEX, 1/4-20, ELASTIC LOCK
11	1	23116	WASHER, FLAT, 1/4, S/S
10	1	14617	NUT, HEX, 1/4-20, BLACK OXIDE
9	1	20477	TIMER, SOLID STATE, 3 SEC
8	1	14692	NUT, HEX, 10-24, ELASTIC LOCK
7	1	41350	BUZZER ASSY, w/ TERMINALS
6	2	19201	SCREW, PAN HD, 5-40 x .250
5	1	20476	TIMER, 60 MIN, MECH. SWITCH
4	1	104958	PANEL, WELDMENT, MECH. TIMER
3	1	106537	LABEL, CONTROL PANEL, MECH.
2	1	104224	SWITCH, ROCKER, SPDT
1	1	11307	KNOB, TIMER

TOLERANCES (EXCEPT AS NOTED)			
CLEVELAND RANGE INC.			
1333 East 179th St. Cleveland, Ohio 44110-2574			
DECIMAL ± N/A	SCALE 3/8=1	DRAWN BY DUTCHMAN	APPROVED BY
ANGULAR ± N/A	TITLE TIMER ASSEMBLY, MECH. CONTROL REAR MOUNTED, STEAMCRAFT ULTRA 10		
CK	DATE 05-27-93	DRAWING NO. B - 106563	REV. -

THIS DESIGN DESCRIBES A PROPRIETARY ITEM AND IS THE PROPERTY OF CLEVELAND RANGE. THIS DRAWING IS NOT TO BE COPIED OR USED WITHOUT THE APPROVAL OF CLEVELAND RANGE.

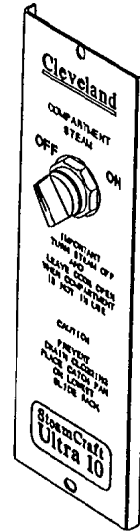
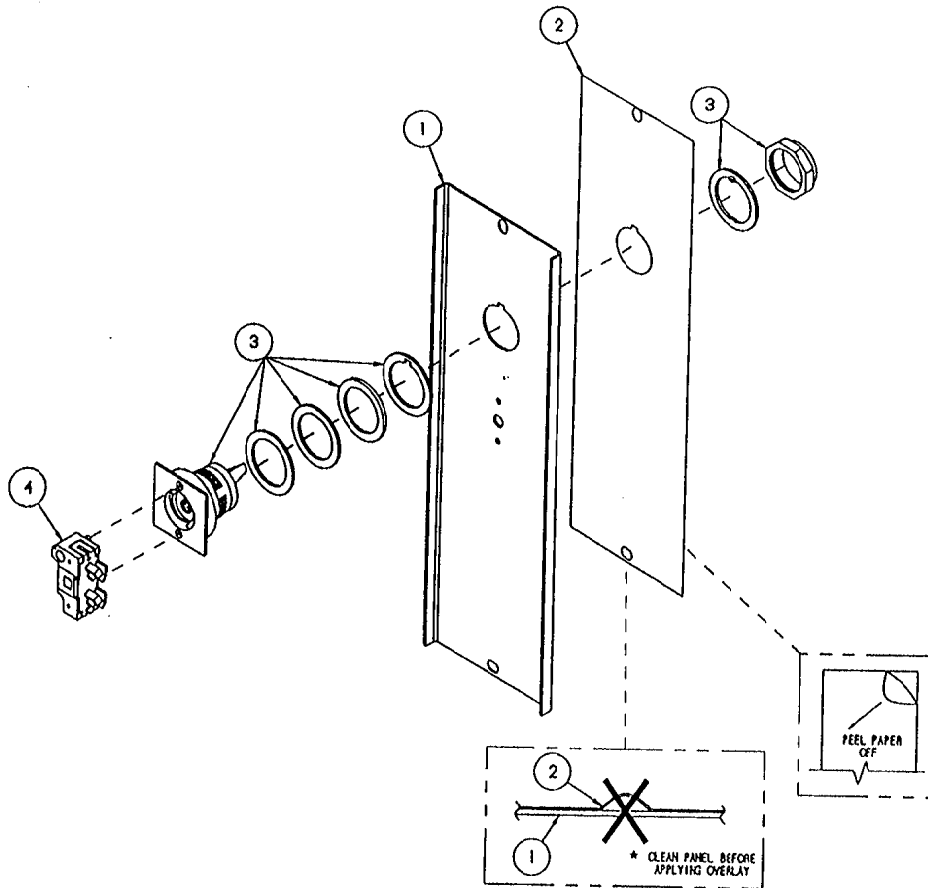

ITEM	QTY.	PART NO.	DESCRIPTION
4	1	102533	BLOCK, CONTACT
3	1	102534	SWITCH, SELECTOR
2	1	106538	LABEL, CONTROL PANEL, ON/OFF
1	1	104961	PANEL WELDMENT, ON/OFF CONTROL

TOLERANCES (EXCEPT AS NOTED)		CLEVELAND RANGE INC. 1333 East 179th St. Cleveland, Ohio 44110-2574	
DECIMAL ± N/A	SCALE 3/8=1	DRAWN BY DUTCHMAN	APPROVED BY BEDFORD
ANGULAR ± N/A	TITLE TIMER ASSEMBLY, ON/OFF CONTROL REAR MOUNTED, STEAMCRAFT ULTRA 10		
CK	DATE 06-04-93	DRAWING NO. B - 106564	REV. -

THIS DESIGN DESCRIBES A PROPRIETARY ITEM AND IS THE PROPERTY OF CLEVELAND RANGE. THIS DRAWING IS NOT TO BE COPIED OR USED WITHOUT THE APPROVAL OF CLEVELAND RANGE.

LET.	REVISIONS	DATE	BY
------	-----------	------	----

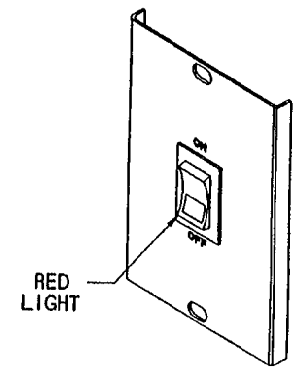
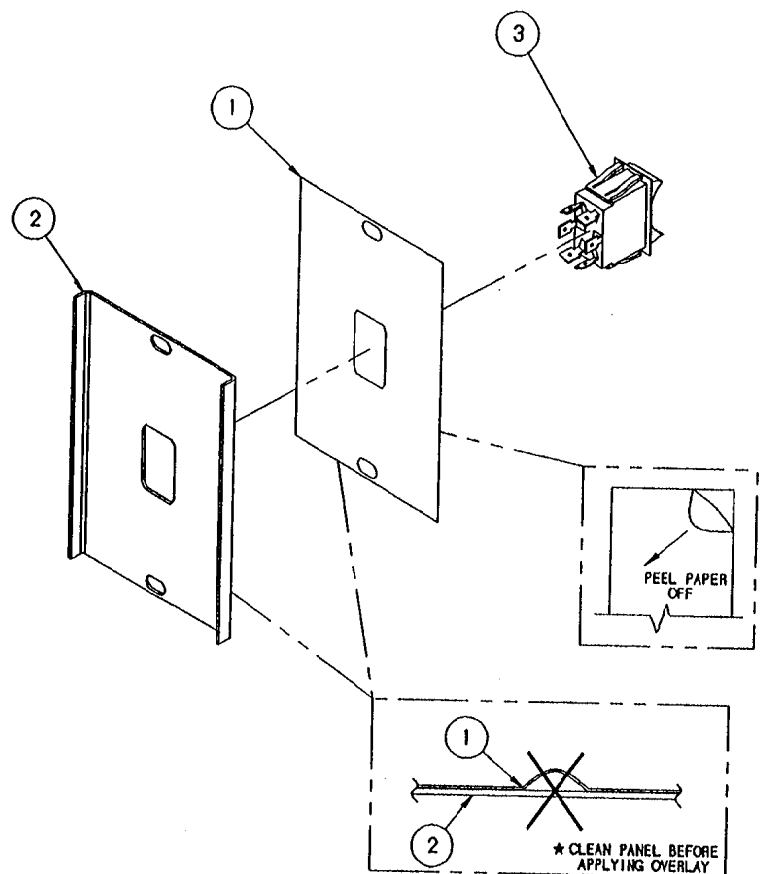

ITEM	QTY.	PART NO.	DESCRIPTION
3	1	19993	SWITCH, ROCKER, DPDT, ON/OFF
2	1	X	PANEL, CONTROL, WELD ASSY
1	1	106694	LABEL, CONTROL PANEL, POWER

TOLERANCES (EXCEPT AS NOTED)		CLEVELAND RANGE INC. 1333 East 179th St. Cleveland, Ohio 44110-2574	
DECIMAL ± N/A	SCALE 1/2=1	DRAWN BY DUTCHMAN	APPROVED BY
ANGULAR ± N/A	TITLE PANEL ASSEMBLY POWER SWITCH STEAMCRAFT 10		
CK	DATE 10-15-93	DRAWING NO. B - 106703	REV. -

THIS DESIGN DESCRIBES A PROPRIETARY ITEM AND IS THE PROPERTY OF CLEVELAND RANGE. THIS DRAWING IS NOT TO BE COPIED OR USED WITHOUT THE APPROVAL OF CLEVELAND RANGE.

LET.	REVISIONS	DATE	BY
A	P/N 108397 ADDED PER EO #C-2375 RI	02-26-93	PJD
B	P/N 108539 ADDED PER EO #C-2423	05-15-93	PJD

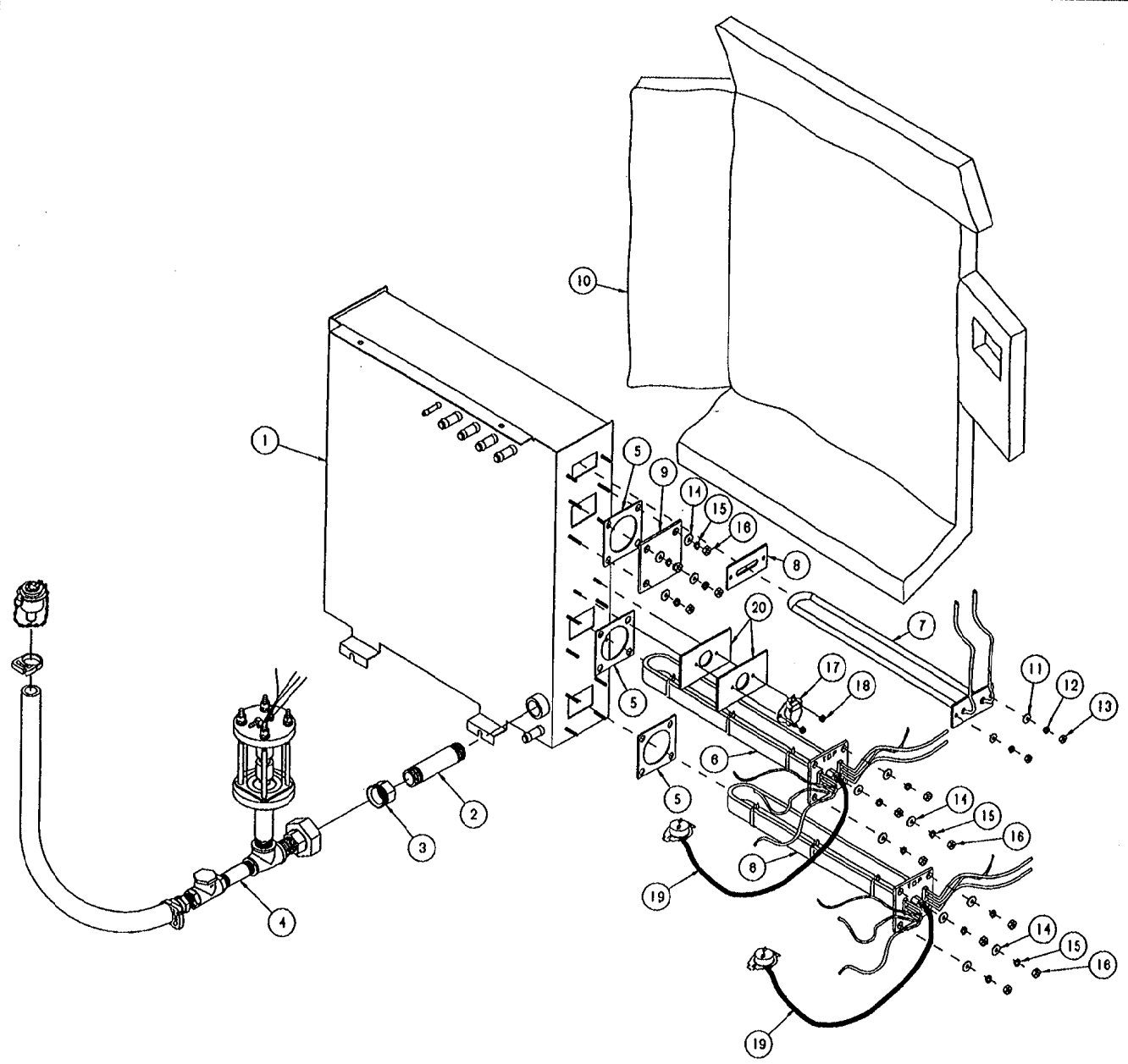

NO.	QTY.	PART NO.	DESCRIPTION
20	2	108397	INSULATOR, THERMOSWITCH
19	2	103731	CAPILLARY, HI LIMIT
18	2	104223	NUT, HEX, ELASTIC LOCK 48-32
17	1	105789	SWITCH, THERMAL DISK, SPDT 190°
16	12	14618	NUT, HEX, 1/4-20 S/S
15	12	23105	WASHER, LOCK, 1/4 S/S
14	12	23118	WASHER, FLAT 1/4 X 5/8
13	2	14659	NUT, HEX, 10-24 S/S
12	2	23113	WASHER, LOCK, SLIT RING, C/D PLATED, #10
11	2	101855	WASHER, FLAT, #10 S/S
10	1	104192	INSULATION, CUT, GENERATOR
9	1	104614	COVER PLATE
8	1	104386	GASKET, DRYING ELEMENTS
	-	1043064	ELEMENT, IMMERSION, 300W, 415 V
7	-	1043083	ELEMENT, IMMERSION, 300W, 380 V
	-	1043082	ELEMENT, IMMERSION, 300W, 480 V
	-	1043081	ELEMENT, IMMERSION, 300W, 240 V
	-	104308	ELEMENT, IMMERSION, 300W, 208 V
	-	1038815	HEATER ASSY, 8 kw, 380 V
	-	1038814	HEATER ASSY, 8 kw, 480 V
6	-	1038812	HEATER ASSY, 8 kw, 415 V
	-	1038811	HEATER ASSY, 8 kw, 240 V
	-	103881	HEATER ASSY, 8 kw, 208 V
5	3	07128	GASKET
4	1	108539	FLOAT & DESCALER ASSY, SC10 ELEC
3	1	21304	UNION, 3/4, BRASS
2	2	14352	NIPPLE, 3/4 X 1 LG, BRASS
1	1	104195	GENERATOR ASSY, WELD, SC 5, 1

THIS DESIGN DESCRIBES A PROPRIETARY ITEM AND IS THE PROPERTY OF CLEVELAND RANGE. THIS DRAWING IS NOT TO BE COPIED OR USED WITHOUT THE APPROVAL OF CLEVELAND RANGE.

TOLERANCES (EXCEPT AS NOTED)		Cleveland Range Inc. 1333 East 179th St. Cleveland, Ohio 44110-2374	
DECIMAL ± N/A	SCALE 1/4"=1"	DRAWN BY DUTCHMAN	APPROVED BY J. B.
ANGULAR ± N/A	TITLE GENERATOR ASSEMBLY SC10, ELECTRIC		
CK	DATE 10-29-92	DRAWING NO. C-108150	REV. B

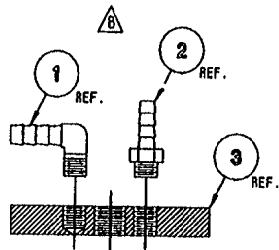

DETAIL A-A
SCALE: 1/2=1

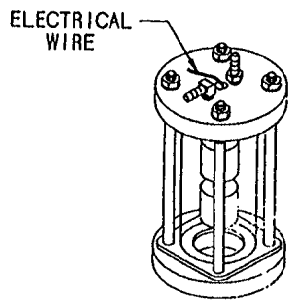

ASSEMBLED VIEW
SCALE: 1/4=1

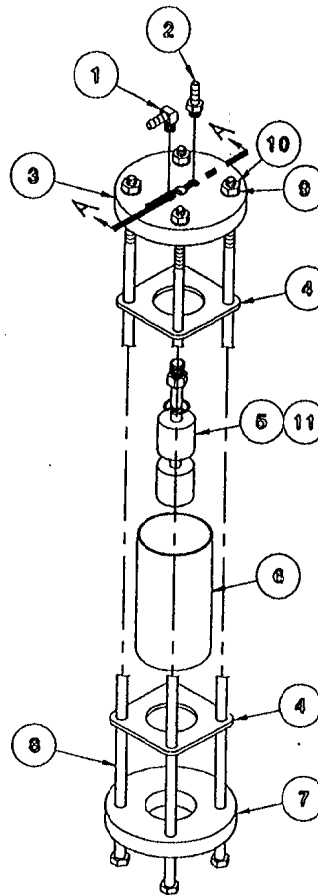

EXPLODED ASSEMBLY
SCALE: 1/4=1

REFERENCE:
260AHM 5 OF 5

LET.	REVISIONS	DATE	BY
A	CORRECTED P/N 105787	7-30-92	SM
B	ROTATED 90° P/NS 105787 & 104380 PER EO #C-2304	10-10-92	PD
C	THIS ASSEMBLY REPLACES P/N 104091 ON SC 3.1, 5.1 ELECT. & SC 10 ELECT. PER EO #C-2277 R3	02-02-93	PD

ITEM	QTY.	PART NO.	DESCRIPTION
11	A/R	00934	SEALANT, RECTORSEAL
10	4	14618	NUT, HEX HEAD, 1/4-20, S/S
9	4	23105	WASHER, SPLIT LOCK, 1/4, S/S
8	4	104276	SCREW, HEX HEAD, 1/4-20 x 5.5, S/S
7	1	104040	CAP, FLOAT BOTTOM
6	1	1040190388	TUBE, POLYSULFONE, 2 x .125 x 3.875
5	1	103728	SWITCH ASSEMBLY, FLOAT
4	2	104041	GASKET, FLOAT ASSEMBLY
3	1	104039	TOP, FLOAT, STEAMCRAFT
2	1	104380	FITTING, HOSE BARB, 1/4 H x 1/8 MPT
1	1	105787	FITTING, HOSE BARB, 90°, 1/4 H x 1/8 MPT

ITEM	QTY.	PART NO.	DESCRIPTION
<p>TOLERANCES (EXCEPT AS NOTED)</p>			
<p>CLEVELAND RANGE INC. 1333 East 179th St. Cleveland, Ohio 44110-2574</p>			
DECIMAL ± N/A	SCALE AS SHOWN	DRAWN BY S. MILEWSKI	APPROVED BY
ANGULAR ± N/A	<p>TITLE △ FLOAT ASSEMBLY, STEAMCRAFT 10 ELECTRIC, 3.1 AND 5.1</p>		
CK	DATE 05-28-92	DRAWING NO. B - 105877	REV. C

THIS DESIGN DESCRIBES A PROPRIETARY ITEM AND IS THE PROPERTY OF CLEVELAND RANGE. THIS DRAWING IS NOT TO BE COPIED OR USED WITHOUT THE APPROVAL OF CLEVELAND RANGE.

107241 Water Level Board

GENERAL DESCRIPTION

THIS SOLID STATE CONTROLLER SERVES AS A DUAL LEVEL WATER SENSING DEVICE. IT'S FUNCTIONS ARE TO:

1. MONITOR AND MAINTAIN A PRESET OPERATING WATER LEVEL WITHIN A STEAM GENERATOR VESSEL, AND
2. MONITOR THE SAFE LOW WATER LIMIT FOR HEATER OPERATION AND PROVIDE HEATER LOCK-OUT FOR UNSAFE OPERATION.

EACH FUNCTION WILL BE CONTROLLED BY RESISTANCE SENSING BETWEEN THE PROBES ("HI" & "LOW" TERMINALS) AND A GROUNDED COMMON ("C" TERMINAL).

LOW PROBE OPERATION

WHEN WATER CONTACTS PROBE, RESISTANCE BETWEEN "LOW" PROBE AND COMMON "C" WILL BE BELOW SET POINT (50 K OHM) AND OUTPUT RELAY WILL BE ACTIVATED IMMEDIATELY TO SUPPLY 120 VAC FROM L1 TO HTR TERMINAL. WHEN CONTACT BETWEEN WATER AND PROBE IS BROKEN (RESISTANCE GREATER THAN 50 K OHM) THE RELAY WILL BE DEACTIVATED WITHIN 0-2 SECONDS.

HI PROBE OPERATION

AS WATER MAKES CONTACT WITH PROBE, RESISTANCE BETWEEN "HI" AND COMMON "C" WILL BE BELOW SET POINT (50 K OHM) AND OUTPUT RELAY IS DEACTIVATED IMMEDIATELY. WHEN WATER BREAKS CONTACT WITH "HI" PROBE DELAY TIMING STARTS. TIMING IS NOT ACCUMULATIVE AND DELAY TIMER WILL BE RESET TO ZERO ANY TIME RESISTANCE BETWEEN "HI" PROBE AND COMMON "C" GOES BELOW SET POINT (50 K OHM). WHEN RESISTANCE BETWEEN HI PROBE AND COMMON "C" REMAINS ABOVE SET POINT FOR MORE THAN 5 SEC. (-2,+0 SEC.) THE OUTPUT RELAY ACTIVATED TO PROVIDE 120 VAC FROM L1 TO WF TERMINAL.

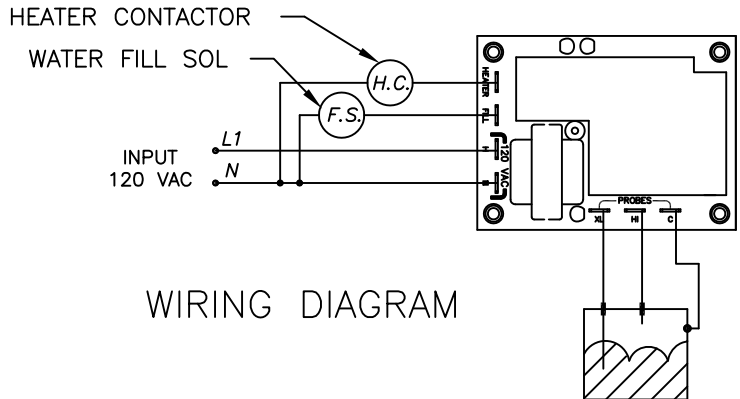
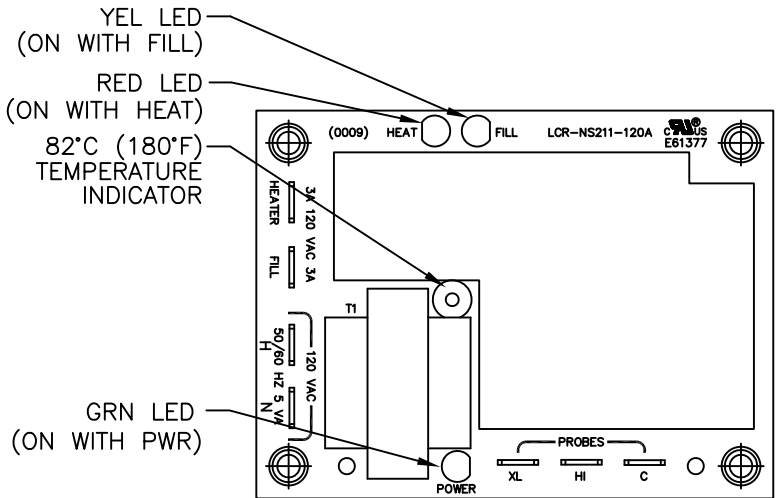

WIRING DIAGRAM

107239 Water Level Probe Assembly

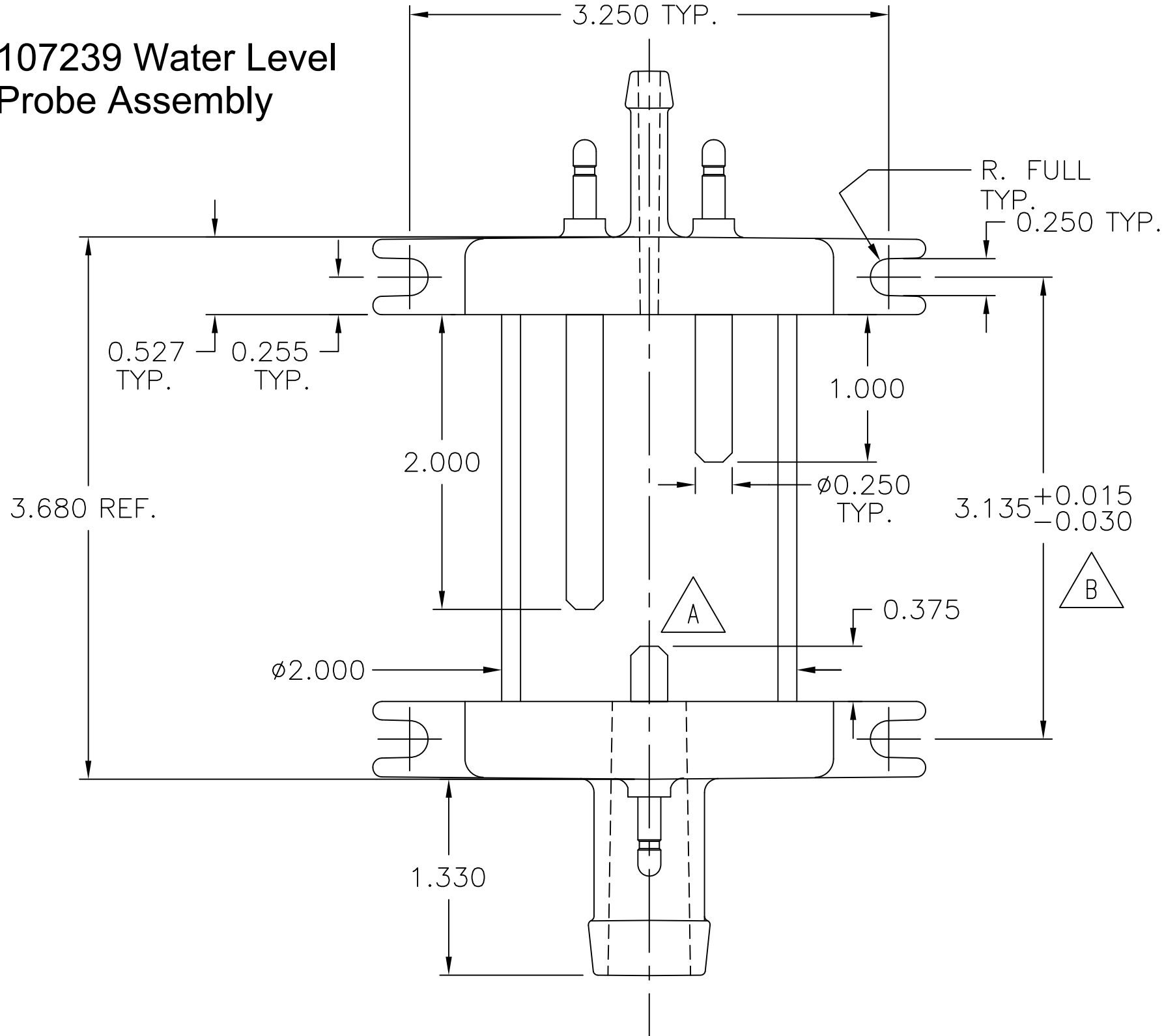

108727

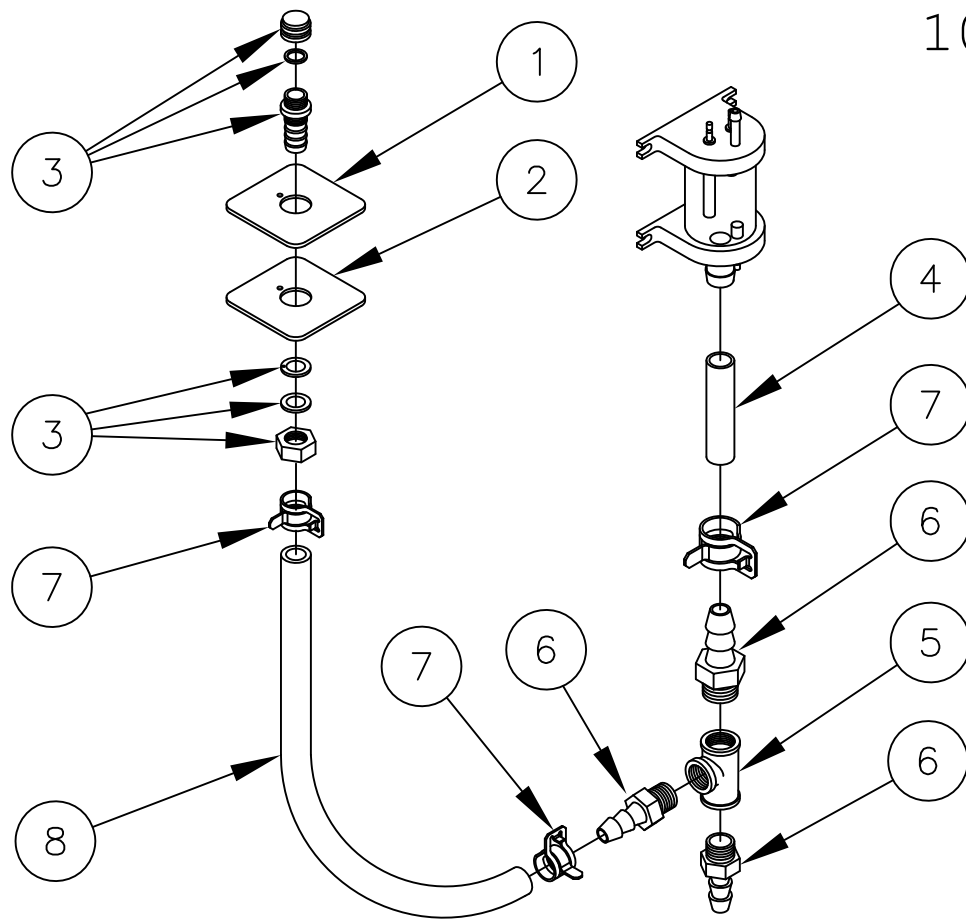

8	1	085112700	HOSE, WHITE, EPDM, 3/4 ID X 27.000 LG
7	2	107312	CLAMP, HOSE METAL TENSION, 1.125 OD HOSE
6	2	06240	FITTING, HOSE BARB, 3/4 X 3/4
5	1	20206	TEE, 3/4 BRASS
4	1	085110600	HOSE, WHITE, EPDM, 3/4 ID X 6.000
3	1	109641	PORT ASSEMBLY, DESCALER
2	1	108724	PLATE, DESCALER PORT CVRSN
1	1	108723	GASKET, DESCALER PORT CVRSN

LET.	REVISIONS	DATE	BY
A	P/N 105966 WAS 105785, P/N 106175 WAS 44164, ADDED P/NS 106123, 106124, & 106127 PER EO #C-2380	03-09-93	PD

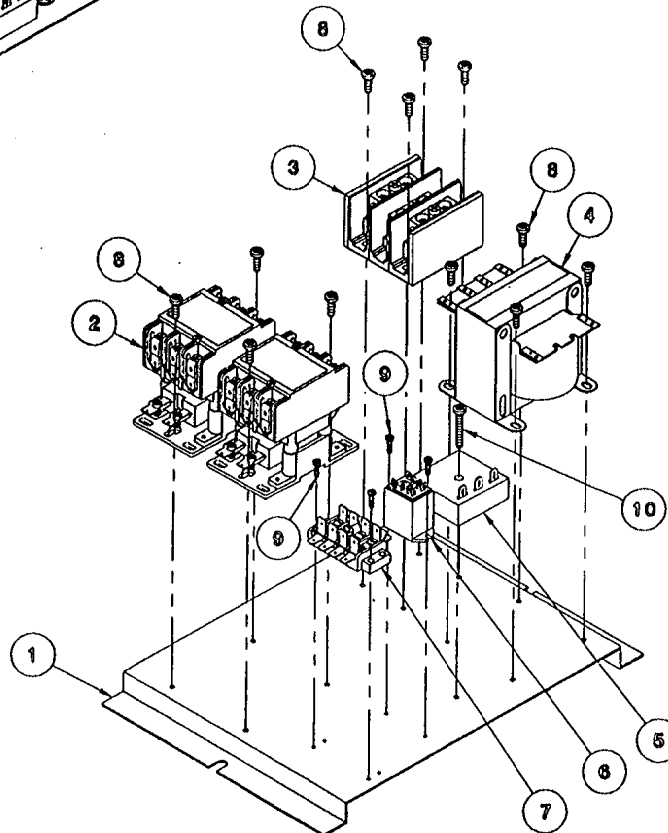
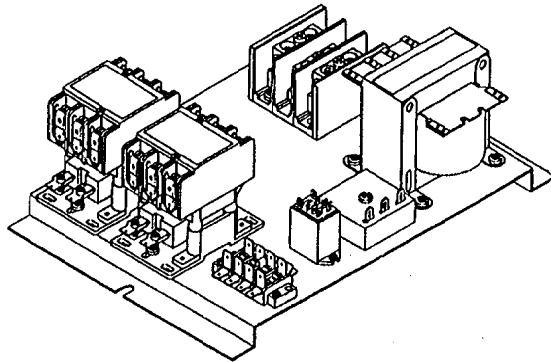

▲	10	1	106124	SCREW, TORX/SLOT PAN HD. #10-32 X 1
▲	9	4	106127	SCREW, TORX/SLOT PAN HD. #6-32 X 1/2
▲	8	12	106123	SCREW, TORX/SLOT PAN HD. #10-32 X 1/2
▲	7	1	106175	TERMINAL BLOCK ASSY, 4 POLE
▲	6	1	105966	RELAY, DPDT, 115V, w/ MTG TABS
	5	1	20478	TIMER, SOLID STATE, 3 MIN
	4	1	20535	TRANSFORMER, 150VA
	3	1	02193	BLOCK, TERMINAL, 3 TERMINALS
	2	2	03509	CONTACTOR, 50 AMP, 104-120V
	1	1	105871	PANEL, ELECTRIC CONTROL MOUNT
	ITEM	QTY.	PART NO.	DESCRIPTION

TOLERANCES (EXCEPT AS NOTED)		CLEVELAND RANGE INC. 1333 East 179th St. Cleveland, Ohio 44110-2574	
DECIMAL ± N/A	SCALE 5/16=1	DRAWN BY S. MILEWSKI	APPROVED BY
ANGULAR ± N/A	TITLE ELECTRIC CONTROL ASSEMBLY STEAMCRAFT 10, ELECTRIC GENERATOR		
CK	DATE 6-12-92	DRAWING NO. B - 105924	REV. A

THIS DESIGN DESCRIBES A PROPRIETARY ITEM AND IS THE PROPERTY OF CLEVELAND RANGE. THIS DRAWING IS NOT TO BE COPIED OR USED WITHOUT THE APPROVAL OF CLEVELAND RANGE.

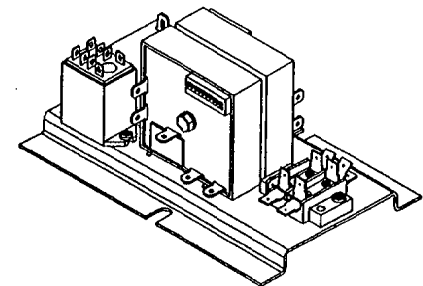
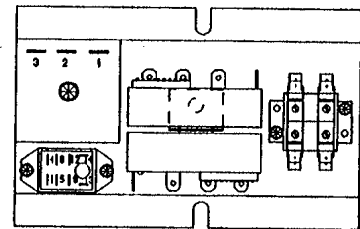
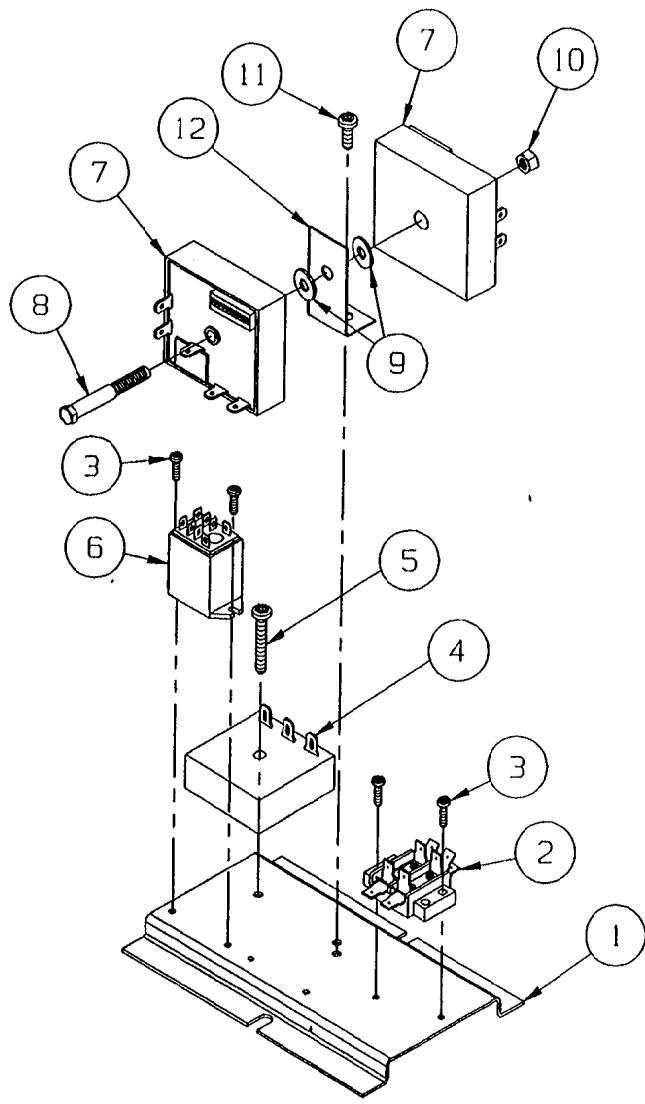

HEAT STANDBY
ULTRA 10 ELECTRIC

ITEM	QTY.	PART NO.	DESCRIPTION
12	1	105955	BRACKET, DUAL TIMER MOUNTING
11	1	108123	SCREW, TORX/SLOT #10-32 X .500" LG.
10	1	14618	NUT, HEX 1/4-20, FULL FINISH
9	2	23118	WASHER, FLAT 1/4-20 S/S
8	1	108118	BOLT, 1/4-20 X 2-1/4, ZINC PLATED
7	2	108911	TIMER, CLEAN LIGHT (DIP SWITCHES)
6	1	105988	RELAY, 120 V, DPDT
5	1	108124	SCREW, TORX/SLOT #10-32 X 1.00" LG.
4	1	108247	INTERVAL TIMER, 2 SEC. ON, 84 SEC. OFF
3	4	108127	SCREW, TORX/SLOT #8-32 X .500" LG.
2	1	44168	TERMINAL, BLOCK ASM, 2 POLE
1	1	108308	BRACKET, OPTION PLATE

TOLERANCES (EXCEPT AS NOTED)		CLEVELAND RANGE INC. 1333 East 179th St. Cleveland, Ohio 44110-2514	
DECIMAL ± N/A	SCALE 3/8" = 1"	DRAWN BY DUTCHMAN	APPROVED BY
ANGULAR ± N/A	TITLE HEAT STANDBY ULTRA 10 ELECTRIC		
CK	DATE 09-15-94	DRAWING NO. C - 10704	REV. -

THIS DESIGN DESCRIBES A PROPRIETARY ITEM AND IS THE PROPERTY OF CLEVELAND RANGE. THIS DESIGN IS NOT TO BE COPIED OR USED WITHOUT THE APPROVAL OF CLEVELAND RANGE.

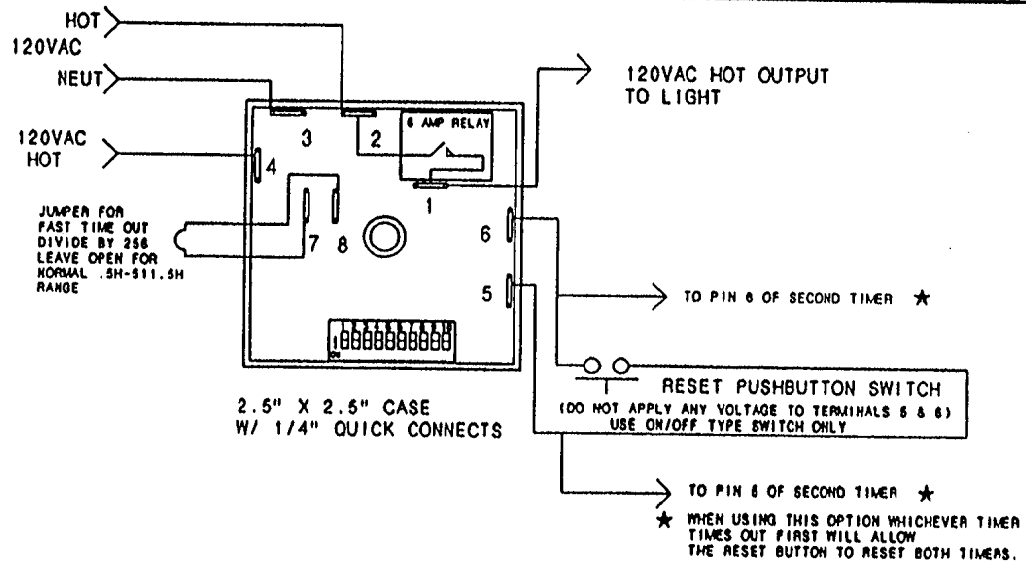

LET.	REVISIONS	DATE	BY
A	SWITCHED LOCATIONS OF 5 & 6 MARKINGS, EO #C-2612R1	1/10/95	DLD

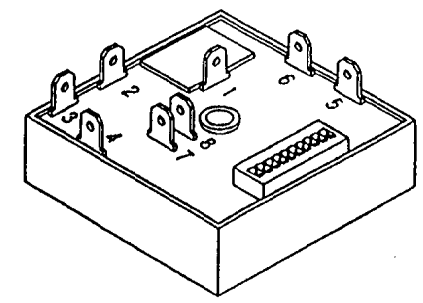

SWITCH #	TIME AMOUNT
1	0.5 HR
2	1.0 HR
3	2.0 HR
4	4.0 HR
5	8.0 HR
6	16.0 HR
7	32.0 HR
8	64.0 HR
9	128.0 HR
10	256.0 HR

COMBINE SWITCHES FOR TIME DELAY IN HOURS

- EXAMPLES:
 37 HRS - SWITCH 7 + SWITCH 4 + SWITCH 2
 250 HRS - SWITCH 9 + SWITCH 8 + SWITCH 7
 + SWITCH 6 + SWITCH 5 + SWITCH 3

ALL SWITCHES ON - 511.5 HOURS

OPERATION:
 SELECT DELAY VIA DIP SWITCH.
 APPLY 120VAC TO THE TIMER ON PINS 2 AND 3.
 AS THE SUPPLY VOLTAGE IS TURNED ON AND OFF TO THE TIMER ON PIN 4 THE TIMER WILL KEEP TRACK OF THE ELAPSED TIME THE SUPPLY VOLTAGE IS ON.
 ONCE THE TIMERS SUPPLY VOLTAGE ON PIN 4 HAS BEEN ON LONGER THAN THE SELECTED DELAY THE RELAY WILL TRANSFER. THIS IN TURN WILL TURN ON THE INDICATOR LIGHT.
 ONCE THIS HAS HAPPENED THE RESET BUTTON WILL BECOME ACTIVE AND ALLOW THE TIMER TO BE RESET.
 IF THE RELAY TRANSFERS AND TERMINAL 4 IS TURNED OFF THE RELAY WILL REMAIN ENERGIZED.
 IF TERMINAL 2 IS POWERED DOWN THE UNIT WILL REMEMBER ITS COUNT FOR 2 DAYS.

SOURCE:
 AIROTRONICS
 2747 RT. 20 E. BOX 326
 CAZENOVIA, N.Y. 13035

SOURCE PART NO : TG CXB1511H5E2S

NOTE: FOR CLEVELAND RANGE PRODUCTION
 SET SWITCHES AT 300 HOURS :
 (10, 7, 5 AND 4 - ON)
 (ALL OTHERS - OFF)

THIS DESIGN DESCRIBES A PROPRIETARY ITEM AND IS THE PROPERTY OF CLEVELAND RANGE. THIS DRAWING IS NOT TO BE COPIED OR USED WITHOUT THE APPROVAL OF CLEVELAND RANGE.

ITEM	QTY.	PART NO.	DESCRIPTION
CLEVELAND RANGE INC.			
1333 East 179th St. Cleveland, Ohio 44110-2574			
TOLERANCES (EXCEPT AS NOTED)	SCALE 1=1	DRAWN BY DUTCHMAN	APPROVED BY
DECIMAL ± .030	TITLE TIMER, CLEAN LIGHT (DIP SWITCHES)		
ANGULAR ± 1°	DATE 05-23-94	DRAWING NO. B - 106911	REV. A
CK			

(INTERMITTENT BLOWDOWN OPTION)

NOTES:

1. 1 ITEM #7 CONNECTION : #3-TIMER (T2) TO NEUTRAL, TERMINAL BLOCK
2. 1 ITEM #8 CONNECTION : #2-TIMER (T2) TO L1, TERMINAL BLOCK
3. 1 ITEM #9 CONNECTION : #13 RELAY (R2) TO TOP CONTACTOR
4. 1 ITEM #11 CONNECTION : #3 TIMER (T2) TO #14 RELAY (R2)
5. 1 ITEM #12, QTY. 1 CONNECTION : #12 RELAY (R2) TO #1 TIMER (T2)
6. 1 ITEM #12, QTY. 1 CONNECTION : #4 RELAY (R2) TO #2 TIMER (T2)

7. 1 ITEM #7 CONNECTION : #3 TIMER (T1) TO NEUTRAL TERMINAL BLOCK
8. 1 ITEM #8 CONNECTION : #2 TIMER (T1) TO NEUTRAL, TERMINAL BLOCK
9. 1 ITEM #10 CONNECTION : #13 RELAY (R1) TO BOTTOM CONTACTOR
10. 1 ITEM #11 CONNECTION : #3 TIMER (T1) TO #14 RELAY (R1)
11. 1 ITEM #12, QTY. 1 CONNECTION : #12 RELAY (R1) TO #1 TIMER (T1)
12. 1 ITEM #12, QTY. 1 CONNECTION : #4 RELAY (R1) TO #2 TIMER (T1)

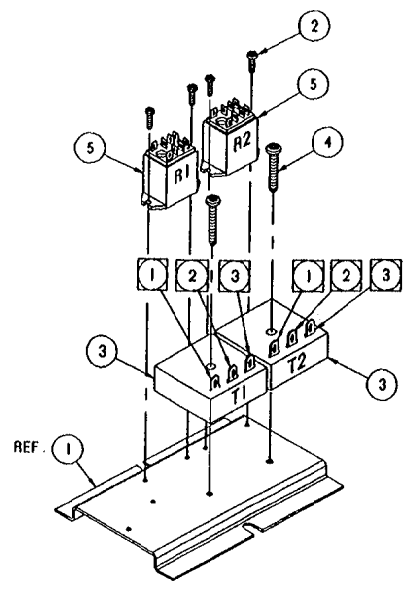
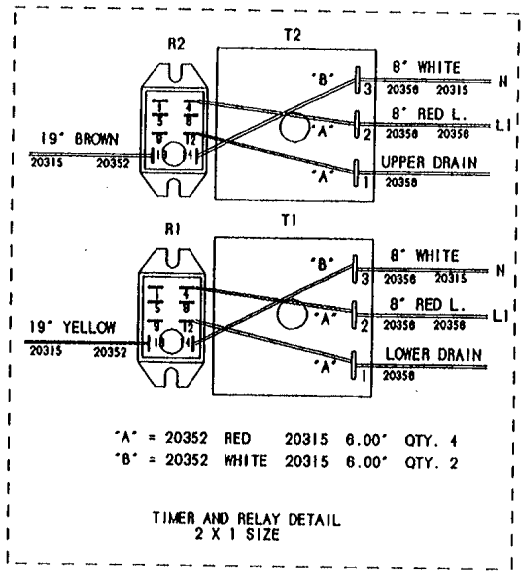
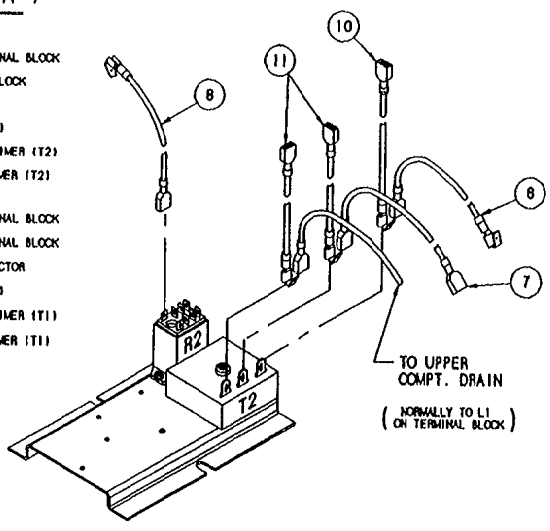
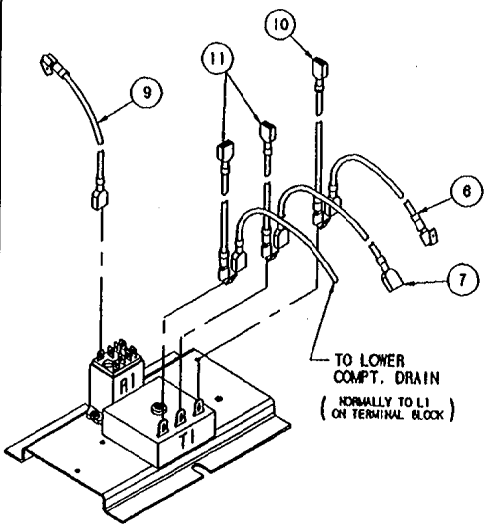

ITEM	QTY.	PART NO.	DESCRIPTION
11	4	1063650800	WIRE ASM. RED 20315/20352, 6.00'
10	2	1063660800	WIRE ASM. WHITE 20315/20352, 6.00'
9	1	1064551900	WIRE ASM. YELLOW 20352/20315, 19.00'
8	1	1064561900	WIRE ASM. BROWN 20352/20315, 19.00'
7	2	1055280800	WIRE ASM. RED, 20358/20358, 8.00'
6	2	1053440800	WIRE ASM. WHITE, 20356/20315 8.00'
5	2	105966	RELAY, 120 V, DPDT
4	2	108124	SCREW, TORX/SLOT 10-32 X 1.00
3	2	106541	TIMER, 1 MIN. ON, 8 SEC. OFF
2	4	108127	SCREW, TORX/SLOT 6-32 X 1/2"
1	-	106308	BRACKET, PLATE

TOLERANCES (EXCEPT AS NOTED)		CLEVELAND RANGE INC. 1333 East 179th St. Cleveland, Ohio 44110-2574	
DECIMAL ± N/A	SCALE N/A	DRAWN BY DUTCHMAN	APPROVED BY
ANGULAR ± N/A	TITLE INTERMITTENT BLOWDOWN STEAMCRAFT 10, ELECTRIC		
CK	DATE 05-10-93	DRAWING NO. C - 106510	REV. -

THIS DESIGN DESCRIBES A PROPRIETARY ITEM AND IS THE PROPERTY OF CLEVELAND RANGE. THIS DRAWING IS NOT TO BE COPIED OR USED WITHOUT THE APPROVAL OF CLEVELAND RANGE.

LET.	REVISIONS	DATE	BY
A	WAS: HIGH LIMIT NOW: FLOAT PER E.O. IC-2361 R1	03-01-93	PJC
B	20351 BLACK WAS FROM FLOAT ONLY PER EO IC-2361 R2	04-14-93	PJC

FOR ON/OFF SWITCH
TIMER

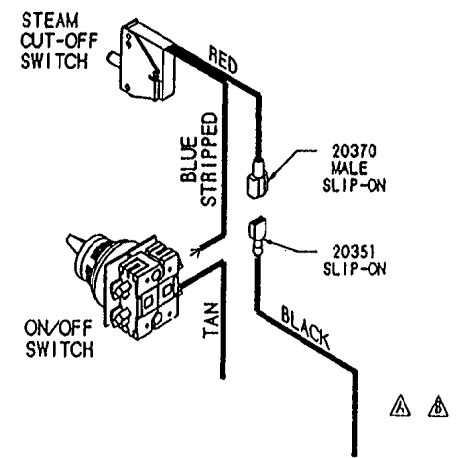

FROM: FLOAT (STANDARD)
GEN. STAND-BY TIMER (SBY OPTION)
BELL TERMINAL (TDS AND SBY OPTIONS TOGETHER)

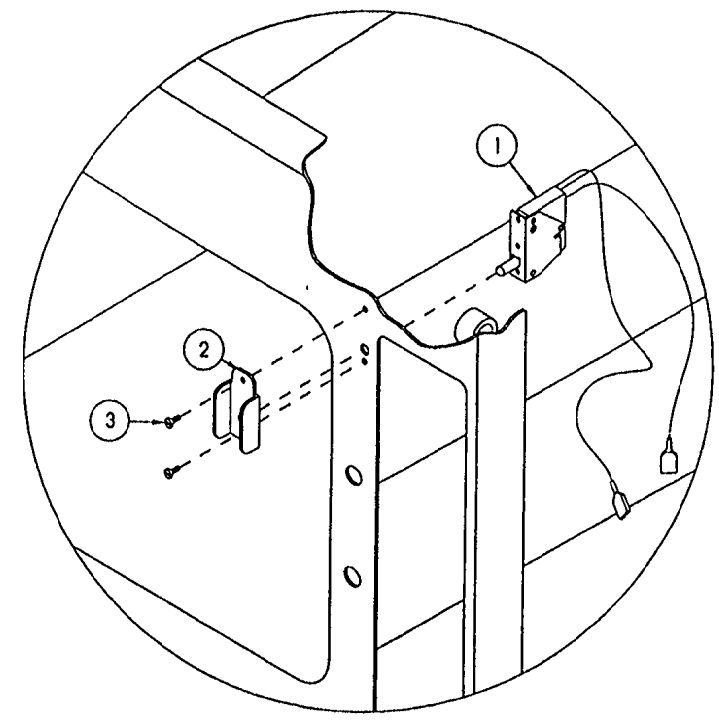

FOR ELECTRICAL & 60 MINUTE
MECHANICAL TIMERS

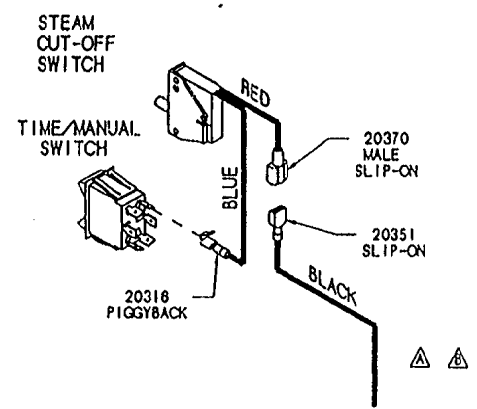

FROM: FLOAT (STANDARD)
GEN. STAND-BY TIMER (SBY OPTION)
BELL TERMINAL (TDS AND SBY OPTIONS TOGETHER)

ITEM	QTY	PART NO.	DESCRIPTION
3	2	105449	SCREW, TRUSS HD. 6-32 X .312, S/S
2	1	105442	GUARD, SWITCH PROTECTION
1	1	104702	SWITCH, CMT. STEAM SHUT-OFF

TOLERANCES (EXCEPT AS NOTED)		CLEVELAND RANGE INC. 1333 East 179th St. Cleveland, Ohio 44110-2574	
DECIMAL ± .030	SCALE N.T.S.	DRAWN BY DUTCHMAN	APPROVED BY
ANGULAR ± 1°	TITLE STEAM CUT-OFF OPTION STEAMCRAFT 3.1 AND 5.1		
CK	DATE 02-03-93	DRAWING NO. C - 106355	REV. B

THIS DESIGN DESCRIBES A PROPRIETARY ITEM
AND IS THE PROPERTY OF CLEVELAND RANGE.
THIS DRAWING IS NOT TO BE COPIED OR USED
WITHOUT THE APPROVAL OF CLEVELAND RANGE.

LET.	REVISIONS	DATE	BY
------	-----------	------	----

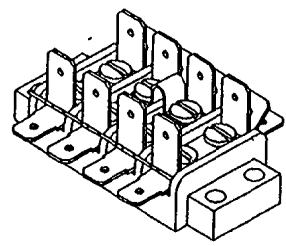
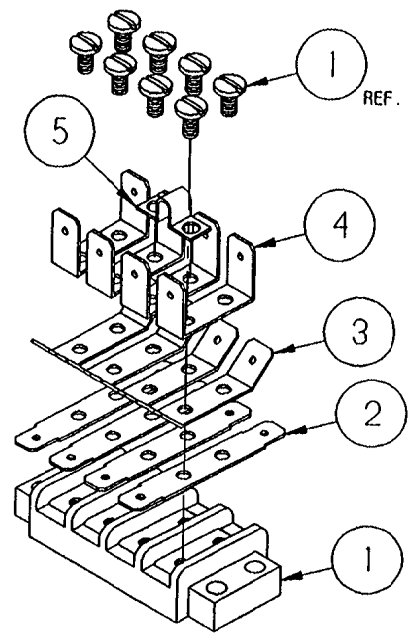

ITEM	QTY.	PART NO.	DESCRIPTION
5	1	20328	TERMINAL CONNECTOR, JUMPER
4	4	20327	TERM. CONN., MALE TAB, 90°
3	4	20326	TERM. CONN., MALE TAB, 45°
2	4	20325	TERMINAL CONN., MALE TAB
1	1	02192	TERMINAL BLOCK, 4 TERMINAL

TOLERANCES (EXCEPT AS NOTED)		CLEVELAND RANGE INC. 1333 East 179th St. Cleveland, Ohio 44110-2574	
DECIMAL ± .030	SCALE 5/8=1	DRAWN BY P. DUTCHMAN	APPROVED BY JTW
ANGULAR ± 1°	TITLE TERMINAL BLOCK ASSEMBLY 4 POLE		
CK	DATE 10-29-92	DRAWING NO. A - 10617	REV. -

THIS DESIGN DESCRIBES A PROPRIETARY ITEM AND IS THE PROPERTY OF CLEVELAND RANGE. THIS DRAWING IS NOT TO BE COPIED OR USED WITHOUT THE APPROVAL OF CLEVELAND RANGE.

- NOTES:
- USE #18 GA. COPPER WIRE (ANN-18-18/30-800V150 C).
 - THE ACTUAL WIRE LENGTH BEFORE HAVING TERMINALS IS THE LENGTH SPECIFIED IN PART DESCRIPTION.
 - TERMINAL PART NUMBER DESCRIPTIONS AS FOLLOWS:
 20356- TERMINAL, SLIP-ON, FULL INSULATED, .032 X .250 TAB
 20316- TERMINAL, FOOTBACK, SLIP-ON, WALE TAB .032 X .250
 20370- TERMINAL, WALE, FULL INSULATED, .032 X .250 TAB
 20338- TERMINAL, RING, INSULATED, #10
 20392- SLIP-ON, FULL INSULATED, .032 X .168 TAB

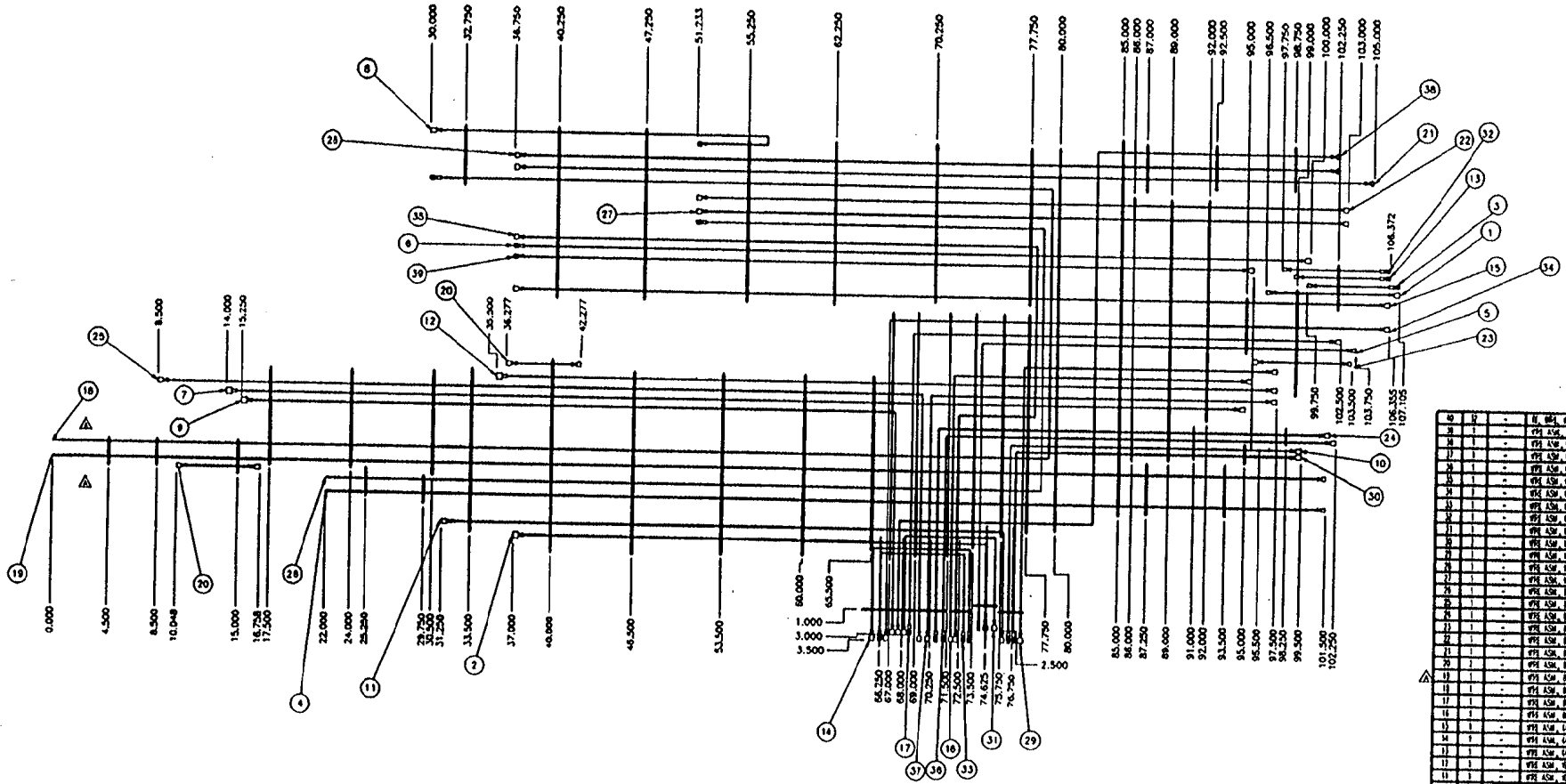

REV.	REVISION	DATE	BY
A	CHANGED WIRE TO #18 GA. COPPER WIRE	11/2/74	WJA
	REVISED 2 PANEL NO. OF PWR WIRE		
	WIRE ON BOTH HOLES IN WIRE		

NO	REV	DESCRIPTION
1	-	WIRE #18
2	-	WIRE #18
3	-	WIRE #18
4	-	WIRE #18
5	-	WIRE #18
6	-	WIRE #18
7	-	WIRE #18
8	-	WIRE #18
9	-	WIRE #18
10	-	WIRE #18
11	-	WIRE #18
12	-	WIRE #18
13	-	WIRE #18
14	-	WIRE #18
15	-	WIRE #18
16	-	WIRE #18
17	-	WIRE #18
18	-	WIRE #18
19	-	WIRE #18
20	-	WIRE #18
21	-	WIRE #18
22	-	WIRE #18
23	-	WIRE #18
24	-	WIRE #18
25	-	WIRE #18
26	-	WIRE #18
27	-	WIRE #18
28	-	WIRE #18
29	-	WIRE #18
30	-	WIRE #18
31	-	WIRE #18
32	-	WIRE #18
33	-	WIRE #18
34	-	WIRE #18
35	-	WIRE #18
36	-	WIRE #18
37	-	WIRE #18
38	-	WIRE #18
39	-	WIRE #18
40	-	WIRE #18
41	-	WIRE #18
42	-	WIRE #18
43	-	WIRE #18
44	-	WIRE #18
45	-	WIRE #18
46	-	WIRE #18
47	-	WIRE #18
48	-	WIRE #18
49	-	WIRE #18
50	-	WIRE #18
51	-	WIRE #18
52	-	WIRE #18
53	-	WIRE #18
54	-	WIRE #18
55	-	WIRE #18
56	-	WIRE #18
57	-	WIRE #18
58	-	WIRE #18
59	-	WIRE #18
60	-	WIRE #18
61	-	WIRE #18
62	-	WIRE #18
63	-	WIRE #18
64	-	WIRE #18
65	-	WIRE #18
66	-	WIRE #18
67	-	WIRE #18
68	-	WIRE #18
69	-	WIRE #18
70	-	WIRE #18
71	-	WIRE #18
72	-	WIRE #18
73	-	WIRE #18
74	-	WIRE #18
75	-	WIRE #18
76	-	WIRE #18
77	-	WIRE #18
78	-	WIRE #18
79	-	WIRE #18
80	-	WIRE #18
81	-	WIRE #18
82	-	WIRE #18
83	-	WIRE #18
84	-	WIRE #18
85	-	WIRE #18
86	-	WIRE #18
87	-	WIRE #18
88	-	WIRE #18
89	-	WIRE #18
90	-	WIRE #18
91	-	WIRE #18
92	-	WIRE #18
93	-	WIRE #18
94	-	WIRE #18
95	-	WIRE #18
96	-	WIRE #18
97	-	WIRE #18
98	-	WIRE #18
99	-	WIRE #18
100	-	WIRE #18
101	-	WIRE #18
102	-	WIRE #18
103	-	WIRE #18
104	-	WIRE #18
105	-	WIRE #18
106	-	WIRE #18
107	-	WIRE #18
108	-	WIRE #18
109	-	WIRE #18
110	-	WIRE #18
111	-	WIRE #18
112	-	WIRE #18
113	-	WIRE #18
114	-	WIRE #18
115	-	WIRE #18
116	-	WIRE #18
117	-	WIRE #18
118	-	WIRE #18
119	-	WIRE #18
120	-	WIRE #18
121	-	WIRE #18
122	-	WIRE #18
123	-	WIRE #18
124	-	WIRE #18
125	-	WIRE #18
126	-	WIRE #18
127	-	WIRE #18
128	-	WIRE #18
129	-	WIRE #18
130	-	WIRE #18
131	-	WIRE #18
132	-	WIRE #18
133	-	WIRE #18
134	-	WIRE #18
135	-	WIRE #18
136	-	WIRE #18
137	-	WIRE #18
138	-	WIRE #18
139	-	WIRE #18
140	-	WIRE #18
141	-	WIRE #18
142	-	WIRE #18
143	-	WIRE #18
144	-	WIRE #18
145	-	WIRE #18
146	-	WIRE #18
147	-	WIRE #18
148	-	WIRE #18
149	-	WIRE #18
150	-	WIRE #18
151	-	WIRE #18
152	-	WIRE #18
153	-	WIRE #18
154	-	WIRE #18
155	-	WIRE #18
156	-	WIRE #18
157	-	WIRE #18
158	-	WIRE #18
159	-	WIRE #18
160	-	WIRE #18
161	-	WIRE #18
162	-	WIRE #18
163	-	WIRE #18
164	-	WIRE #18
165	-	WIRE #18
166	-	WIRE #18
167	-	WIRE #18
168	-	WIRE #18
169	-	WIRE #18
170	-	WIRE #18
171	-	WIRE #18
172	-	WIRE #18
173	-	WIRE #18
174	-	WIRE #18
175	-	WIRE #18
176	-	WIRE #18
177	-	WIRE #18
178	-	WIRE #18
179	-	WIRE #18
180	-	WIRE #18
181	-	WIRE #18
182	-	WIRE #18
183	-	WIRE #18
184	-	WIRE #18
185	-	WIRE #18
186	-	WIRE #18
187	-	WIRE #18
188	-	WIRE #18
189	-	WIRE #18
190	-	WIRE #18
191	-	WIRE #18
192	-	WIRE #18
193	-	WIRE #18
194	-	WIRE #18
195	-	WIRE #18
196	-	WIRE #18
197	-	WIRE #18
198	-	WIRE #18
199	-	WIRE #18
200	-	WIRE #18

SEE NOTES 1, 2, 3

CLEVELAND RANGE INC.			
1200 East 17th St., Cleveland, Ohio 44115-3775			
SCALE	1:1	DATE	11/2/74
BY	WJA	CHECKED BY	GJA
PROJECT	WIRE HARNESS, ELECTRIC, ATMOS. STEAMCRANT 10		
REV.	11/2/74	DRAWING NO.	D-106190

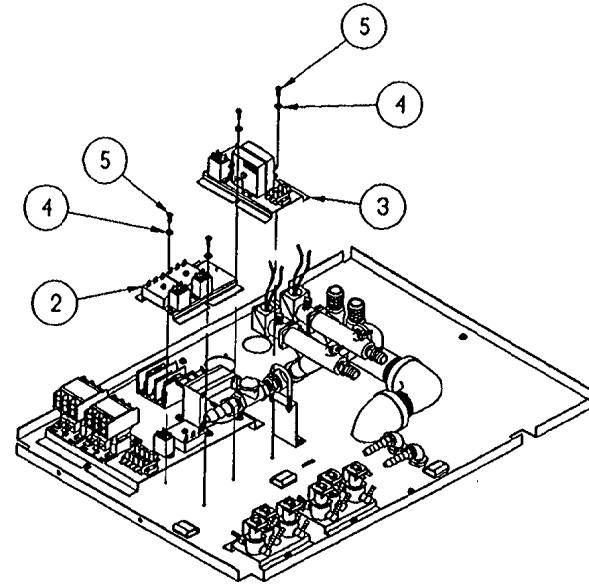
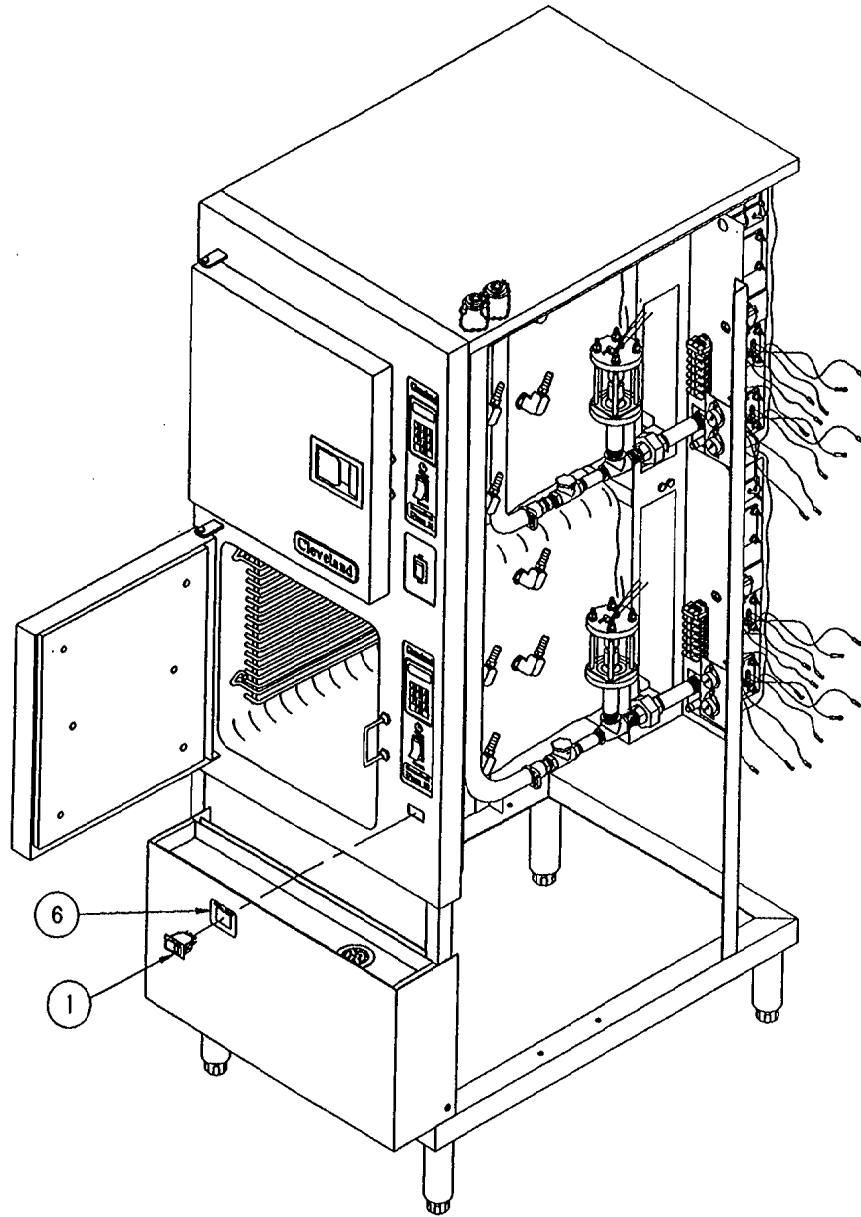

THIS DESIGN DESCRIBES A PROPRIETARY ITEM AND IS THE PROPERTY OF CLEVELAND RANGE. THIS DRAWING IS NOT TO BE COPIED OR USED WITHOUT THE APPROVAL OF CLEVELAND RANGE.

ITEM	QTY.	PART NO.	DESCRIPTION
6	1	107011	LABEL, CLEAN LIGHT
5	4	108123	SCREW, TORX/SLOT 10-32 X 1/2
4	4	101855	WASHER, FLAT #10 S/S
3	1	107042	HEAT STANDBY ULTRA 10 ELECTRIC
2	1	108510	INTERMITTENT BLOWDOWN ULTRA 10 ELECTRIC
1	1	19994	SWITCH, ROCKER, SPST

TOLERANCES (EXCEPT AS NOTED)		CLEVELAND RANGE INC. 1333 East 179th St. Cleveland, Ohio 44110-2574	
DECIMAL ± N/A	SCALE 3/16=1	DRAWN BY DUTCHMAN	APPROVED BY
ANGULAR ± N/A	TITLE INSTRUCTION, INSTALLATION ULTRA 10, ELEC. CLEAN LIGHT, INT. BLOWDOWN & HEAT STANDBY		
CK	DATE 09-15-94	DRAWING NO. C - 260AKT	REV. -

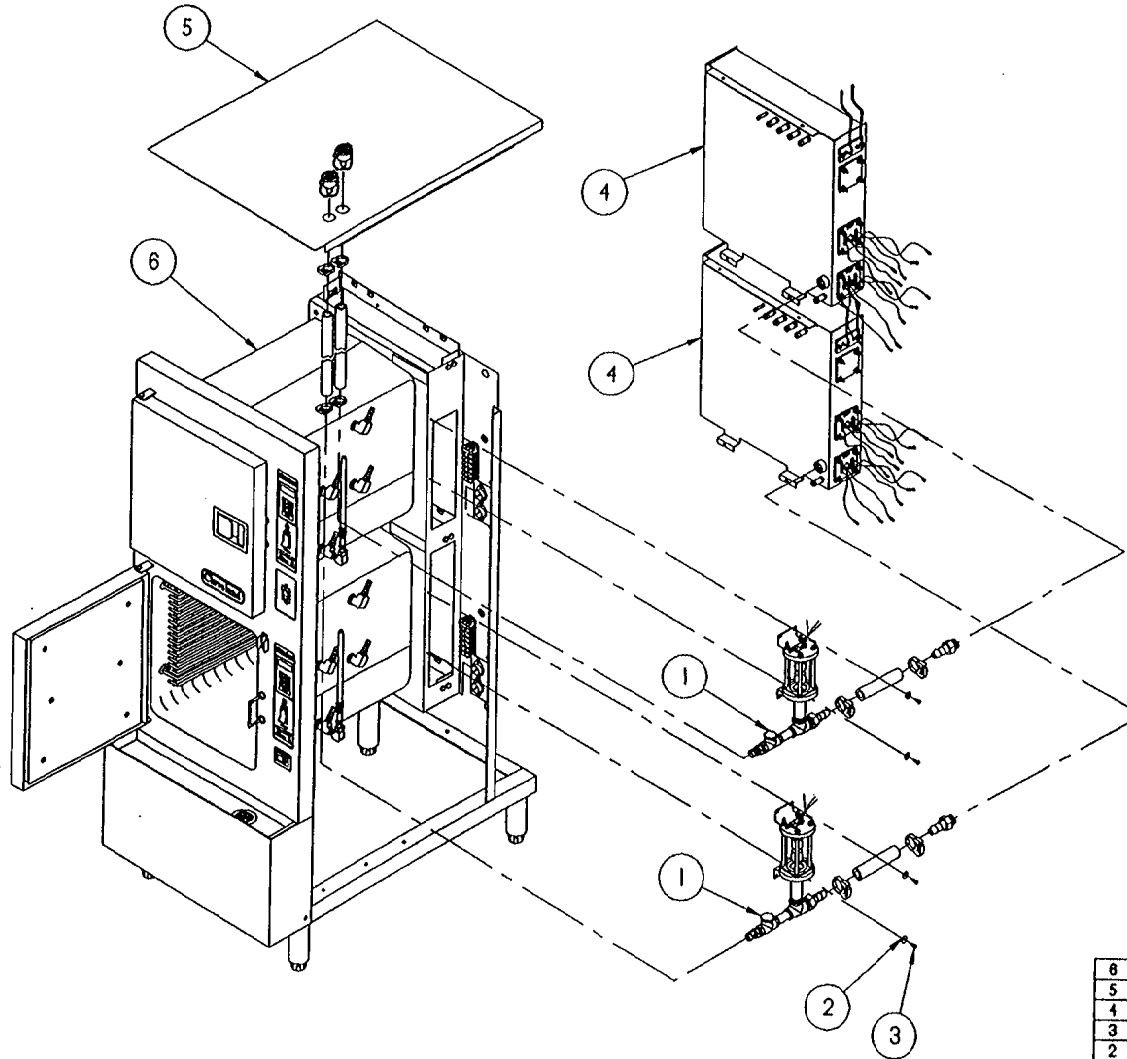

THIS DESIGN DESCRIBES A PROPRIETARY ITEM AND IS THE PROPERTY OF CLEVELAND RANGE. THIS DRAWING IS NOT TO BE COPIED OR USED WITHOUT THE APPROVAL OF CLEVELAND RANGE.

ITEM	QTY.	PART NO.	DESCRIPTION
6	-	24CEA10	BODY ASSEMBLY, SC ULTRA 10 ELECTRIC
5	-	105881	PANEL, TOP, SC ULTRA 10 ELECTRIC
4	-	104194	GENERATOR ASSY.
3	4	106123	SCREW, TORX/SLOT #10-32 X 1/2
2	4	101855	WASHER, FLAT #10 S/S
1	2	108539	FLOAT/DESCALER ASSY SC ULTRA 10 ELEC

TOLERANCES (EXCEPT AS NOTED)		CLEVELAND RANGE INC. 1333 East 179th St. Cleveland, Ohio 44110-2574	
DECIMAL ± N/A	SCALE 1/8"=1"	DRAWN BY DUTCHMAN	APPROVED BY
ANGULAR ± N/A	TITLE INSTALLATION OF FLOAT/DESCALER TO BODY STEAMCRAFT ULTRA 10 ELECTRIC		
CK	DATE 08-02-94	DRAWING NO. C - 260AKZ	REV. -

NOTES:

1) SEE DRAWING 108131 FOR HOSE LOCATIONS.

2) ITEMS MARKED "REF" ARE INCLUDED IN THIS BILL OF MATERIALS FOR REFERENCE ONLY. THE "ASSEMBLED UNIT" DRAWING DEPICTS THE ACTUAL REQUIRED PARTS FOR THIS ASSEMBLY.

108728 - CLEANING PORT KIT.

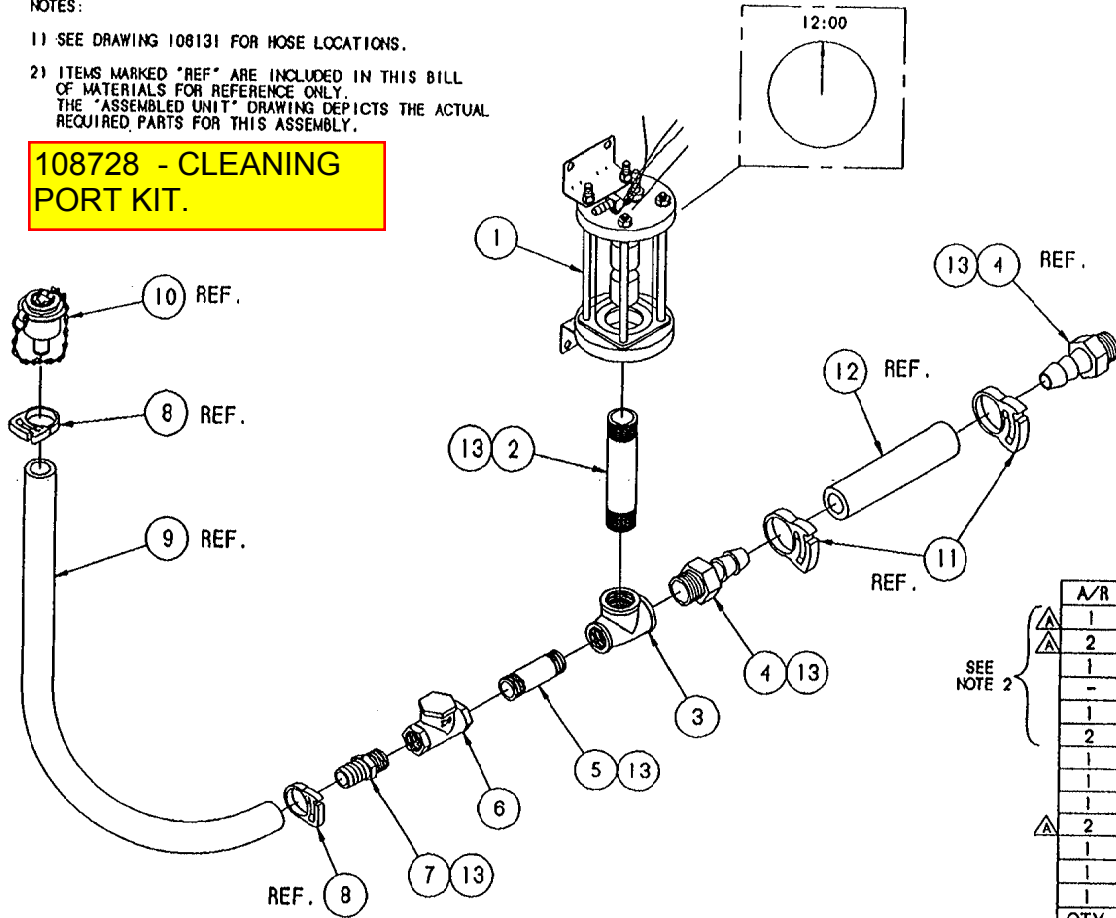

LET.	REVISIONS	DATE	BY
A	SEE E.O. #C-2631	08-02-94	PJD

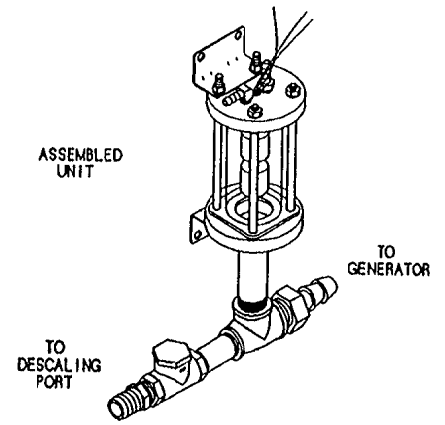

A/R	A/R	13	00934	SEALANT, RECTORSEAL
1	1	12	1080930512	HOSE, SILICONE 1-1/8 OD X 3/4 ID X 5-1/2"
2	2	11	105847	CLAMP, PLASTIC, 1-1/8" HOSE
1	1	10	108428	PORT ASSEMBLY, DESCALER
-	1	9	1058454600	HOSE, NORPRENE, 3/4 OD X 1/2 ID X 46" LG.
1	-		1058452400	HOSE, NORPRENE, 3/4 OD X 1/2 ID X 24" LG.
2	2	8	105848	CLAMP, PLASTIC, 3/4" OD HOSE
1	1	7	08237	FITTING, 1/2 X 1/2 MPT
1	1	6	108156	CHECK VALVE, 1/2" SWING W/ RUBBER SEAT
1	1	5	14331	NIPPLE, 1/2 X 2-1/2, BRASS
2	2	4	08240	FITTING, HOSE BARB, 3/4 T X 3/4
1	1	3	20210	TEE, 3/4 X 3/4 X 1/2, BRASS
1	1	2	14352	NIPPLE, 3/4 X 4", BRASS
1	1	1	105957	FLOAT, ASSEMBLY, STEAMCRAFT
QTY.	QTY.	ITEM	PART NO.	DESCRIPTION

THIS DESIGN DESCRIBES A PROPRIETARY ITEM AND IS THE PROPERTY OF CLEVELAND RANGE. THIS DRAWING IS NOT TO BE COPIED OR USED WITHOUT THE APPROVAL OF CLEVELAND RANGE.

SC 10 ELECTRIC TOP GENERATOR	SC 10 ELECTRIC BOTTOM GENERATOR	TOLERANCES (EXCEPT AS NOTED)		CLEVELAND RANGE INC. 1333 East 179th St. Cleveland, Ohio 44110-2574		
		DECIMAL ± .030	SCALE 1/4"			DRAWN BY DUTCHMAN
		ANGULAR ± 1°	TITLE	FLOAT AND DESCALER ASSEMBLY STEAMCRAFT 10, ELECTRIC		DATE 05-20-93

LET.	REVISIONS	DATE	BY
A	P/N 105786 MOVED TO MIDDLE SOLENOID IN PICTORIAL PER EO #C-2304	10-28-92	PD
B	NEW VALVE REPLACING P/N 22218 (PICTORIAL ONLY) PER E.O.#C-2221 RI	01-28-93	PJD

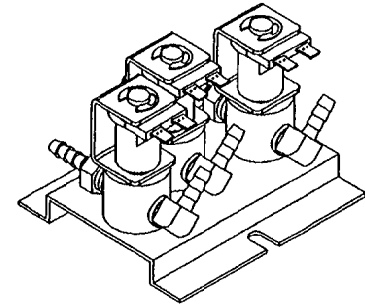
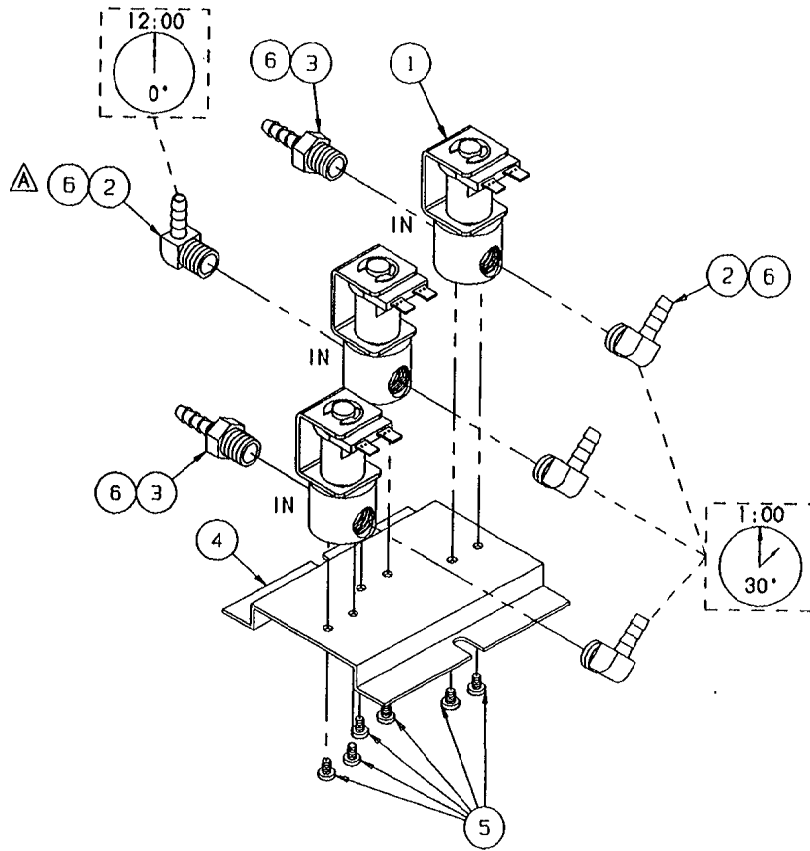

ITEM	QTY.	PART NO.	DESCRIPTION
6	A/R	00934	SEALANT, RECTORSEAL
5	6	101872	SCREW, THREAD CUTTING, #8-32 x .25
4	1	104284	BRACKET, MOUNTING, SOLENOID
3	2	104381	FITTING, HOSE BARB, 1/4 H x 1/4, ST.
2	4	105786	FITTING, HOSE BARB, 1/4 H x 1/4, 90°
1	3	22218	VALVE, SOLENOID, 1/4", N.C., 120 V

TOLERANCES (EXCEPT AS NOTED)		CLEVELAND RANGE INC. 1333 East 179th St. Cleveland, Ohio 44110-2574	
DECIMAL ± N/A	SCALE 1/2=1	DRAWN BY S. MILEWSKI	APPROVED BY
ANGULAR ± N/A	TITLE VALVE ASSEMBLY, WATER INLET STEAMCRAFT 10, ELECTRIC		
CK	DATE 7-16-92	DRAWING NO. B - 105981	REV. B

THIS DESIGN DESCRIBES A PROPRIETARY ITEM AND IS THE PROPERTY OF CLEVELAND RANGE. THIS DRAWING IS NOT TO BE COPIED OR USED WITHOUT THE APPROVAL OF CLEVELAND RANGE.

NOTE :

1.) BEND TUBE TO FIT.

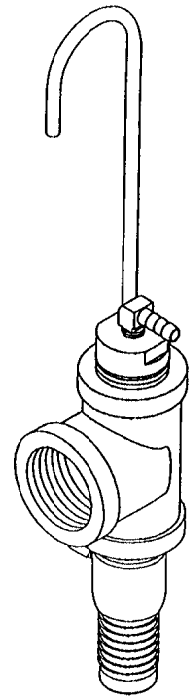
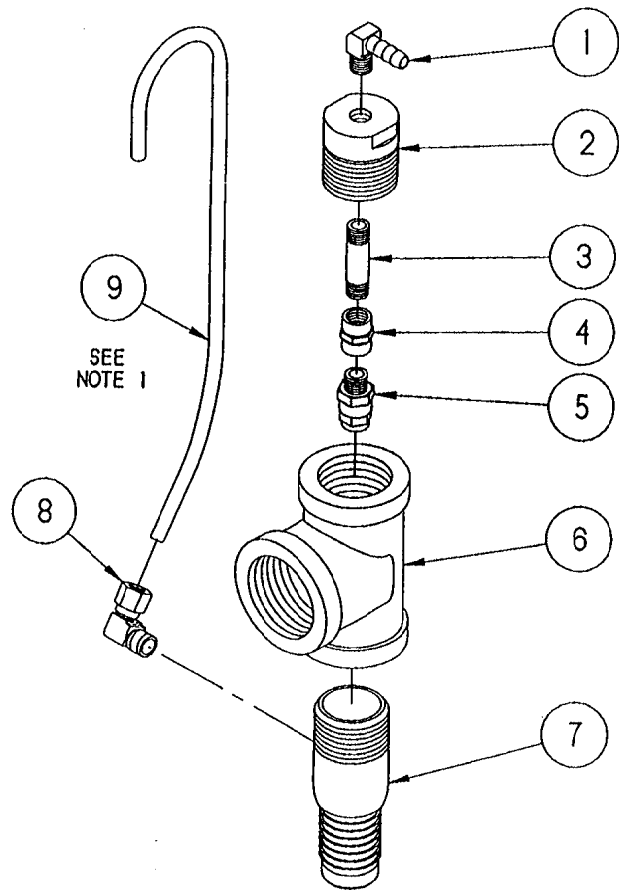

ASSEMBLED UNIT

LET.	REVISIONS	DATE	BY
A	P/N 565191 WAS 14481, P/NS 06192 & 106595 ADDED PER E.O. 10C-2452	06-28-93	PJD

ITEM	QTY.	PART NO.	DESCRIPTION
▲ 9	1	106595	TUBE, COPPER, BREATHER, SC10
▲ 8	1	06192	FITTING, HOSE 1/4 X 1/8 MPT X 90
▲ 7	1	565191	FITTING, HOSE 1" W/ 1/8 HOLE
6	1	105783	TEE, 1 X 1 X 1-1/4, BLACK
5	1	14555	NOZZLE, SPRAY, 1/8 FULL JET
4	1	104838	COUPLING, FULL 1/8, BRASS
3	1	14297	NIPPLE, 1/8 X 1-1/2, BRASS
2	1	06230	FITTING, COMPARTMENT DRAIN
1	1	105786	FITTING, HOSE 1/4 X 1/4 MPT X 90

TOLERANCES (EXCEPT AS NOTED)		CLEVELAND RANGE INC. 1333 East 179th St. Cleveland, Ohio 44110-2574	
DECIMAL ± N/A	SCALE 1/2" = 1"	DRAWN BY PJD	APPROVED BY
ANGULAR ± N/A	TITLE DRAIN ASSEMBLY STEAMCRAFT 10		
CK	DATE 03-08-93	DRAWING NO. B - 1061711	REV. A

THIS DESIGN DESCRIBES A PROPRIETARY ITEM AND IS THE PROPERTY OF CLEVELAND RANGE. THIS DRAWING IS NOT TO BE COPIED OR USED WITHOUT THE APPROVAL OF CLEVELAND RANGE.

LET.	REVISIONS	DATE	BY
------	-----------	------	----

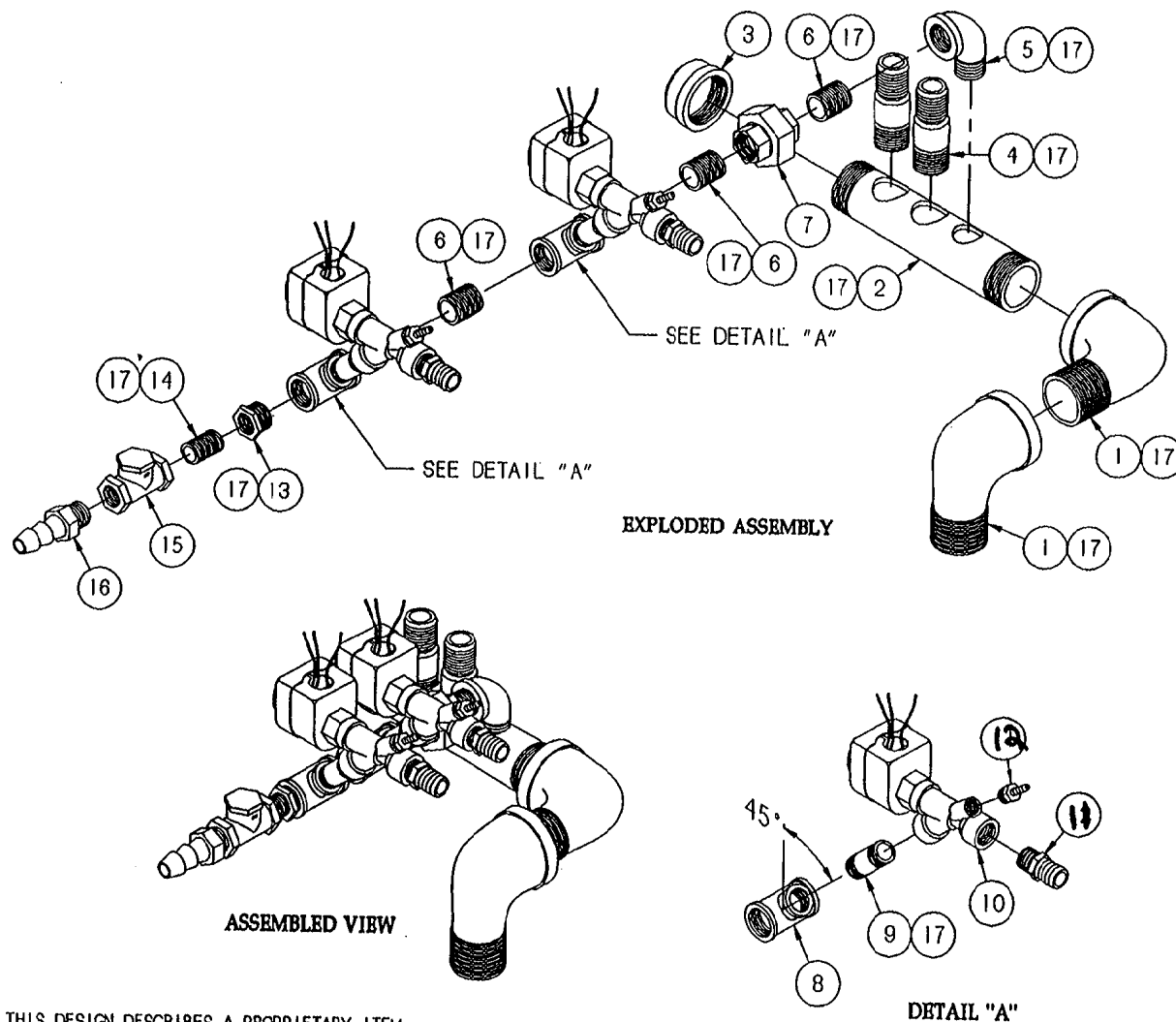

ITEM	QTY.	PART NO.	DESCRIPTION
17	A/R	00934	SEALANT, RECTORSEAL
16	1	06248	FITTING, HOSE BARB, 1/2 H x 1/2 MPT
15	1	22149	VALVE, SWING CHECK, 1/2 NPT
14	1	14323	NIPPLE, 1/2 x CLOSE, BLACK
13	1	02585	BUSHING, HEX, 3/4 x 1/2, BLACK
12	2	104381	FITTING, HOSE BARB, 3/4 H x 1/4 NPT
11	2	06241	FITTING, HOSE BARB, 3/4 H x 1/2 NPT
10	2	22221	VALVE, SOLENOID, 1/2", 15 PSI
9	2	14327	NIPPLE, 1/2 x 2", BLACK
8	2	20209	TEE, 3/4 x 3/4 x 1/2, BLACK
7	1	21305	UNION, 3/4, BLACK
6	3	14343	NIPPLE, 3/4 x CLOSE, BLACK
5	1	05259	ELBOW, STREET, 90°, 3/4, BLACK
4	2	14481	FITTING, HOSE BARB, 1" H x 1" NPT
3	1	03058	CAP, PIPE, 1-1/2, BLACK
2	1	13252	MANIFOLD, DRAIN, 1-1/2, BLACK
1	2	05292	ELBOW, STREET, 90°, 1-1/2", BLACK

TOLERANCES (EXCEPT AS NOTED)		CLEVELAND RANGE INC. 1333 East 179th St. Cleveland, Ohio 44110-2574	
DECIMAL ± N/A	SCALE 1/4=1	DRAWN BY S. MILEWSKI	APPROVED BY
ANGULAR ± 1°	TITLE DRAIN MANIFOLD STEAMCRAFT 10 ELECTRIC		
CK	DATE 05-27-92	DRAWING NO. B - 105875	REV. -

THIS DESIGN DESCRIBES A PROPRIETARY ITEM AND IS THE PROPERTY OF CLEVELAND RANGE. THIS DRAWING IS NOT TO BE COPIED OR USED WITHOUT THE APPROVAL OF CLEVELAND RANGE.

NOTE:
 REMOVE AND DISCARD PLASTIC TAIL PIECE;
 REPLACE WITH ITEM 2

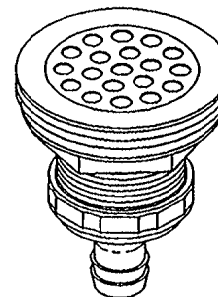
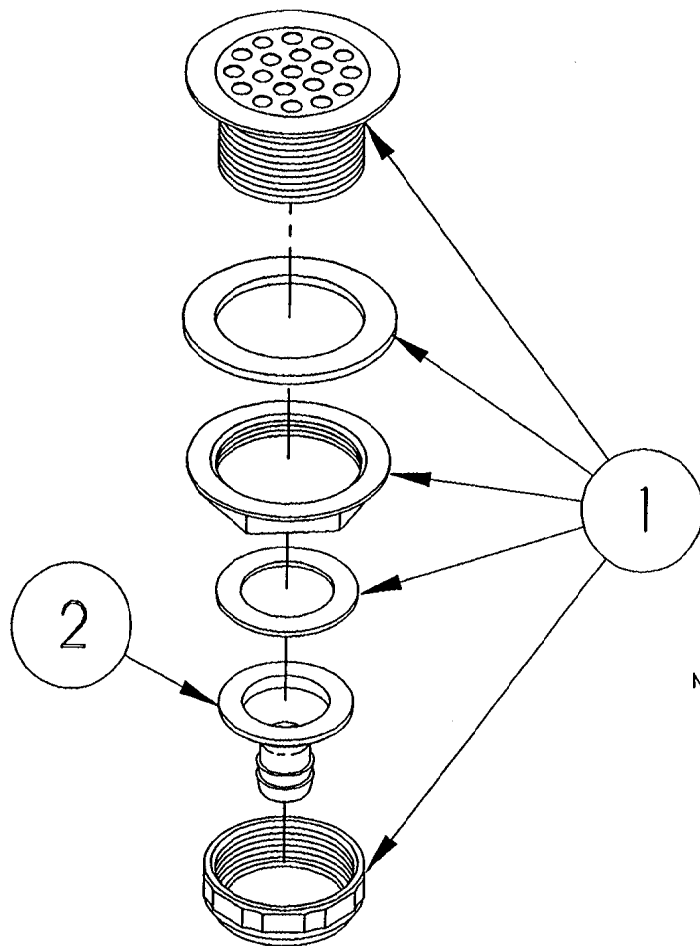

LET.	REVISIONS	DATE	BY
------	-----------	------	----

SEE
 NOTE

2	1	106736	TAIL PIECE, DRAIN	
1	1	105280	DRAIN, FITTING HOSE ADAPTER	
ITEM	QTY.	PART NO	DESCRIPTION	
TOLERANCES (EXCEPT AS NOTED)		CLEVELAND RANGE INC. 1333 East 179th St. Cleveland, Ohio 44110-2574		
DECIMAL ± N/A	SCALE 1/2"	DRAWN BY ATHERTON	APPROVED BY	
ANGULAR ± N/A	TITLE DRAIN ASSEMBLY TABLETOPS AND STEAMCRAFT 10			
CK	DATE 01-06-92	DRAWING NO. A-106737	REV.	-

THIS DESIGN DESCRIBES A PROPRIETARY ITEM
 AND IS THE PROPERTY OF CLEVELAND RANGE.
 THIS DRAWING IS NOT TO BE COPIED OR USED
 WITHOUT THE APPROVAL OF CLEVELAND RANGE.

LET.	REVISIONS	DATE	BY
A	SEE E.O. #C-2454 RI	05-27-94	PJD

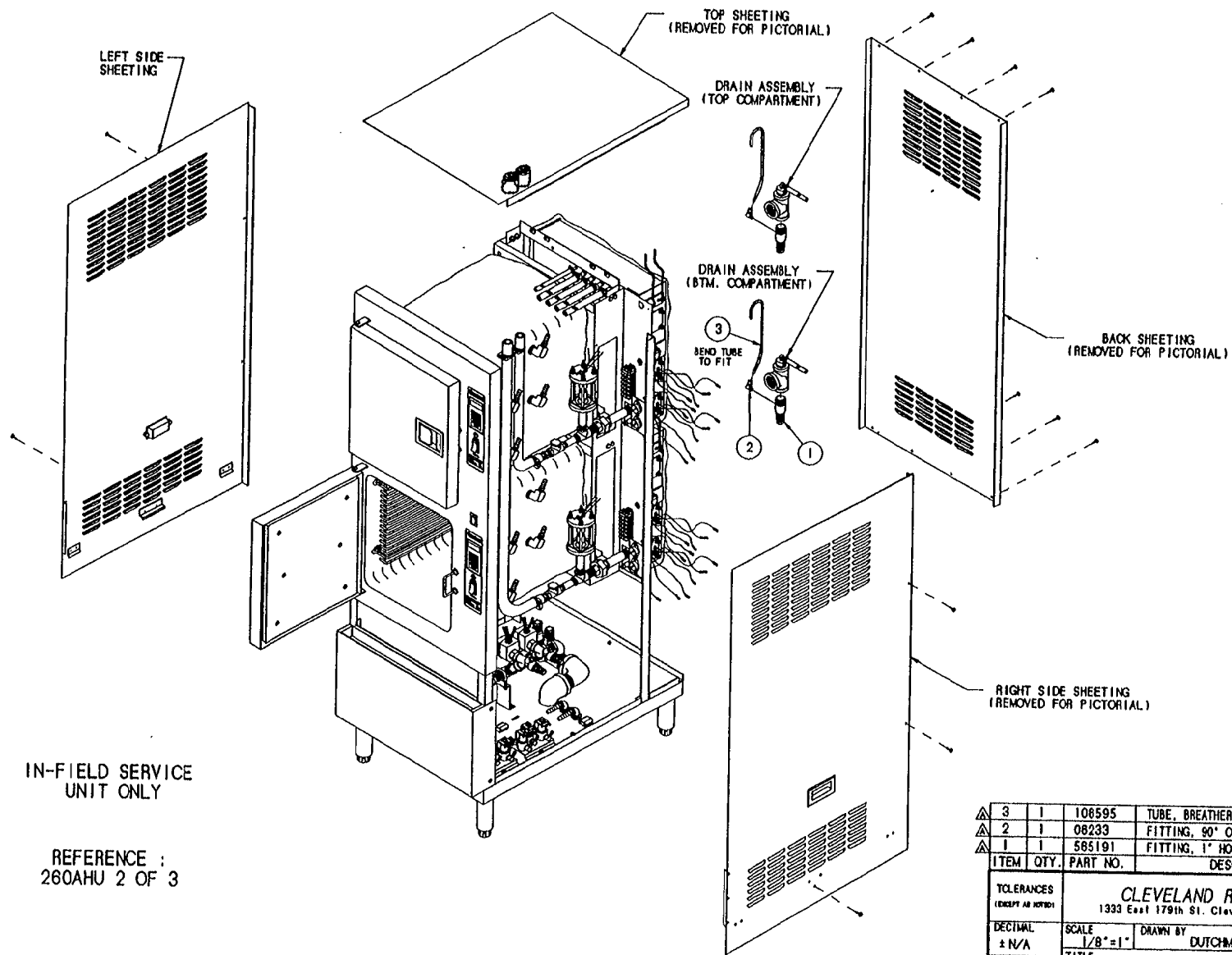

IN-FIELD SERVICE
UNIT ONLY

REFERENCE :
260AHU 2 OF 3

THIS DESIGN DESCRIBES A PROPRIETARY ITEM
AND IS THE PROPERTY OF CLEVELAND RANGE.
THIS DRAWING IS NOT TO BE COPIED OR USED
WITHOUT THE APPROVAL OF CLEVELAND RANGE.

ITEM	QTY.	PART NO.	DESCRIPTION
△ 3	1	106595	TUBE, BREATHER - FORMED
△ 2	1	08233	FITTING, 90° COMP., 3/8 T X 1/8 MPT
△ 1	1	585191	FITTING, 1" HOSE X 1" MPT, W-1/8 HOLE

TOLERANCES (EXCEPT AS NOTED)		CLEVELAND RANGE INC. 1333 East 179th St. Cleveland, Ohio 44110-2574	
DECIMAL ± N/A	SCALE 1/8" = 1"	DRAWN BY DUTCHMAN	APPROVED BY
ANGULAR ± N/A	TITLE KIT, BREATHER TUBE - RETROFIT STEAMCRAFT 10 (INSTALLATION)		
CK	DATE 07-02-93	DRAWING NO. C - 106597	REV. A

LET.	REVISIONS	DATE	BY
------	-----------	------	----

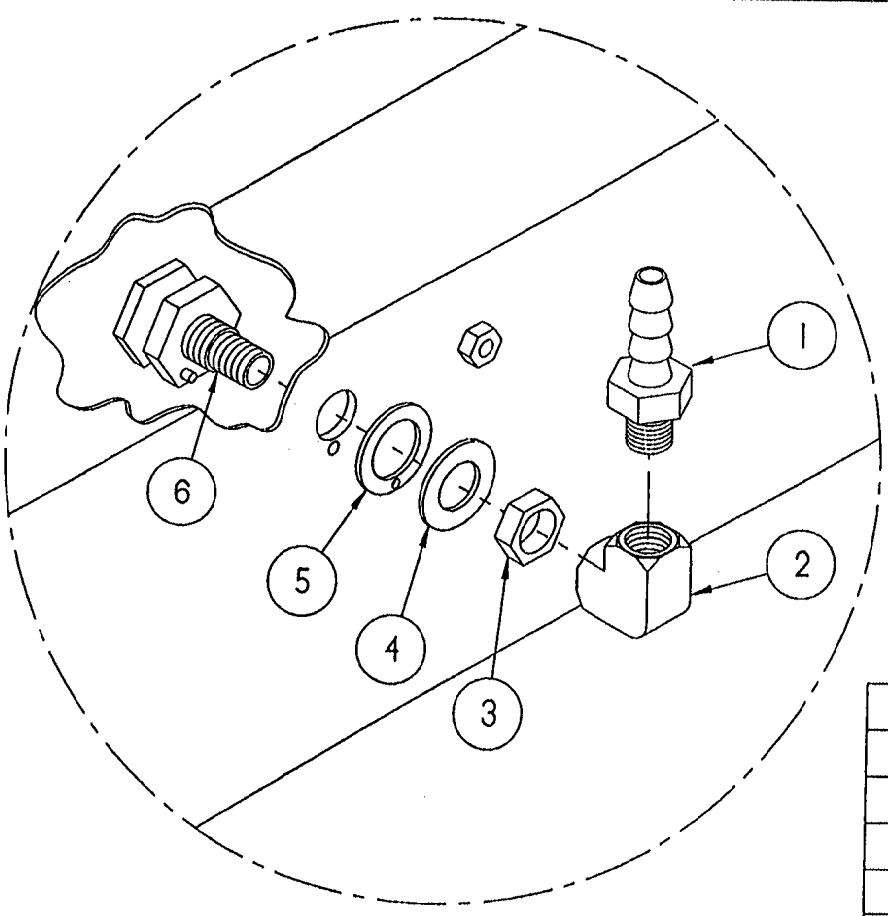

TYPICAL APPLICATION

ITEM	QTY.	PART NO.	DESCRIPTION
6	1	104009	FITTING, ASSY, STEAM SUPPLY
5	1	104082	GASKET, STEAM INJECTOR
4	1	104232	WASHER, FLAT S/S
3	1	104081	NUT, JAM 5/8-18, BRASS
2	1	05236	ELBOW, 1/4" X 90°, BRASS
1	1	104048	FITTING, HOSE 1/2 H X 1/4 MPT

TOLERANCES (EXCEPT AS NOTED)		CLEVELAND RANGE INC. 1333 East 179th St. Cleveland, Ohio 44110-2574	
DECIMAL ± .030	SCALE 1/2"	DRAWN BY DUTCHMAN	APPROVED BY THOMPSON
ANGULAR ± 1°	TITLE SPRAY NOZZLE ASSEMBLY STEAMCRAFT 3.1, 5.1 AND 10		
CK	DATE 02-12-93	DRAWING NO. A - 1062301	REV. -

THIS DESIGN DESCRIBES A PROPRIETARY ITEM AND IS THE PROPERTY OF CLEVELAND RANGE. THIS DRAWING IS NOT TO BE COPIED OR USED WITHOUT THE APPROVAL OF CLEVELAND RANGE.

- NOTES : 1.) USE LOCTITE #222 - LOW STRENGTH (#104146) ON ITEM 4
 2.) USE RTV (#00933) ON ITEM 8
 3.) ORIENT LONGER SIDE OF ITEM 5 TOWARD HANDLE

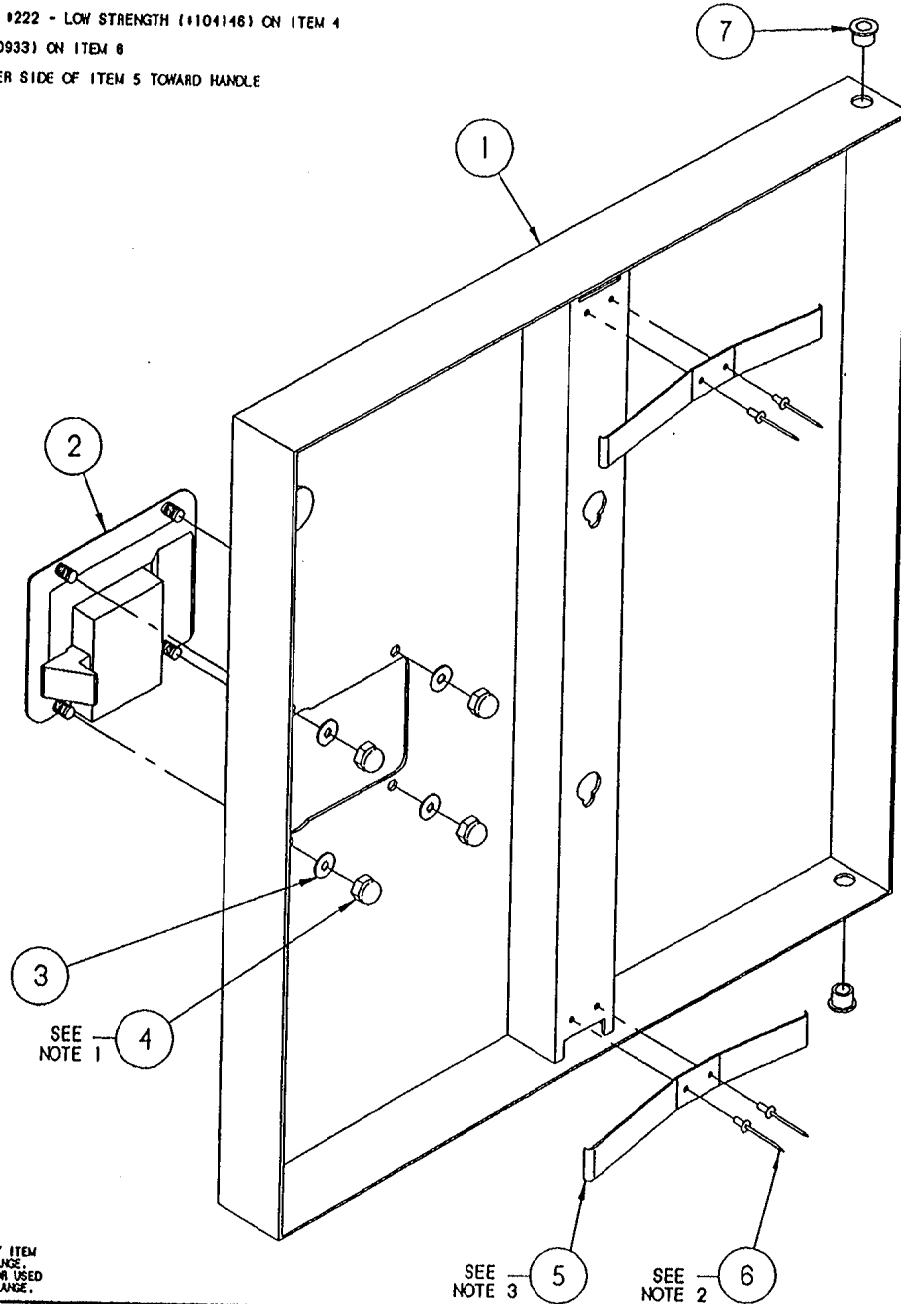

LET.	REVISIONS	DATE	BY
A	REDRAWN CADKEY, ADDED P/N'S 105901 NAMEPLATE AND 104987 TINNERMAN NUT, PICTORIAL CHANGE PER EO #C-2441R2	06-30-93	PJD
B	P/N'S 105901 & 104987 REF. ONLY PER E.O. #C-2441 R3	06-05-93	PJD
C	REMOVED P/N'S 105901 AND 104987 PER E.O. #C-2441 R8	06-07-94	PJD

SEE NOTE 1

SEE NOTE 3

SEE NOTE 2

THIS DESIGN DESCRIBES A PROPRIETARY ITEM AND IS THE PROPERTY OF CLEVELAND RANGE. THIS DRAWING IS NOT TO BE COPIED OR USED WITHOUT THE APPROVAL OF CLEVELAND RANGE.

ITEM	QTY.	PART NO.	DESCRIPTION
7	2	103841	BUSHING, BRONZE
6	4	18357	RIVET, 1/8" DIA. FLUSH BREAK, S/S
5	2	102228	SPRING, DOOR
4	4	14879	NUT, #10-24 ACORN, S/S
3	4	101855	WASHER, #10 FLAT, S/S
2	1	103843	LATCH, DOOR - PADDLE TYPE
1	1	1042072	DOOR, OUTER WELD ASSY, W/SCS TAB, S/C S.1, H.L.

TOLERANCES (EXCEPT AS NOTED)		CLEVELAND RANGE INC. 1333 East 179th St. Cleveland, Ohio 44110-2574	
DECIMAL ± N/A	SCALE 5/8=1	DRAWN BY JTW	APPROVED BY
ANGULAR ± N/A	TITLE DOOR, OUTER ASSEMBLY, H.L. SC 5.1 & SC 10 W-SWITCH ACTUATOR		
CK	DATE 02-04-93	DRAWING NO. C - 1042062	REV. C

NOTES:

- 1.) USE LOCKTITE #222 - LOW STRENGTH (104146) ON ITEM 4
- 2.) USE RTV (100933) ON ITEM 6
- 3.) ORIENT LONGER SIDE OF ITEM 5 TOWARD HANDLE

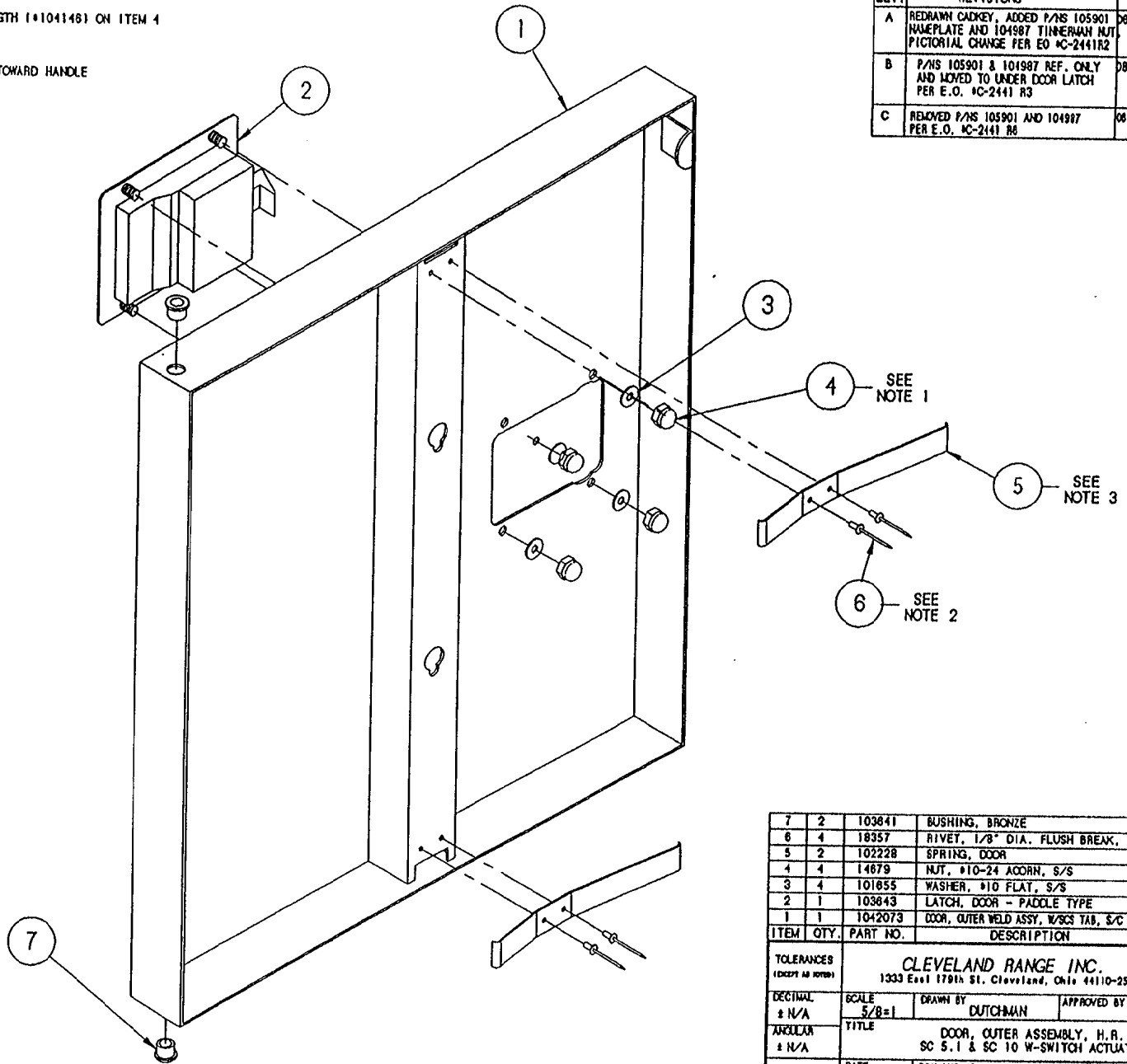

LET.	REVISIONS	DATE	BY
A	REDRAWN CADKEY, ADDED P/N'S 105901 NAMEPLATE AND 104987 TINNEMAN NUT. PICTORIAL CHANGE PER EO KC-2441R2	08-28-93	PJD
B	P/N'S 105901 & 104987 REF. ONLY AND MOVED TO UNDER DOOR LATCH PER E.O. KC-2441 R3	08-05-93	PJD
C	REMOVED P/N'S 105901 AND 104987 PER E.O. KC-2441 R6	08-07-94	PJD

ITEM	QTY.	PART NO.	DESCRIPTION
7	2	103841	BUSHING, BRONZE
6	4	18357	RIVET, 1/8" DIA. FLUSH BREAK, S/S
5	2	102228	SPRING, DOOR
4	4	14679	NUT, #10-24 ACORN, S/S
3	4	101855	WASHER, #10 FLAT, S/S
2	1	103843	LATCH, DOOR - PADDE TYPE
1	1	1042073	DOOR, OUTER WELD ASSY, W/SCS TAB, S/C S.1, H.R.

CLEVELAND RANGE INC. 1333 East 179th St. Cleveland, Ohio 44110-2574			
TOLERANCES <small>(EXCEPT AS NOTED)</small>		SCALE 5/8"=1"	
DECIMAL ± N/A		DRAWN BY DUTCHMAN	
ANGULAR ± N/A		APPROVED BY	
TITLE DOOR, OUTER ASSEMBLY, H.R. SC 5.1 & SC 10 W-SWITCH ACTUATOR			
DATE 08-30-93		DRAWING NO. C - 1042063	
CK		REV. C	

THIS DESIGN DESCRIBES A PROPRIETARY ITEM AND IS THE PROPERTY OF CLEVELAND RANGE. THIS DRAWING IS NOT TO BE COPIED OR USED WITHOUT THE APPROVAL OF CLEVELAND RANGE.

LET.	REVISIONS	DATE	BY
A	ADDED ITEMS 1 & 8, ITEM 2 WAS 104205	6/25/91	JPB

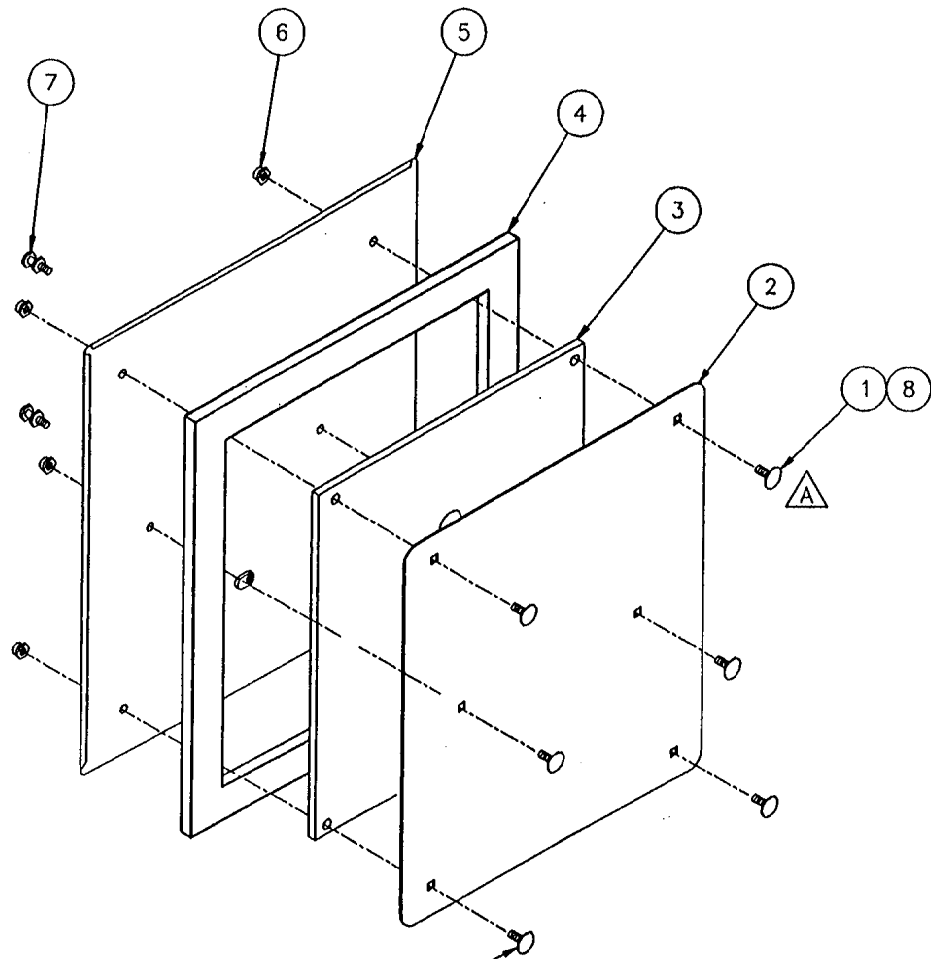

RTV APPLIED AROUND
SQ. ON BASE OF HEAD

ITEM	QTY	PART NO.	DESCRIPTION
8	A/R	00932	SEALANT, CLEAR RTV
7	2	66508	STUD, DOOR MOUNTING, INNER
6	6	14665	NUT, HEX LOCK, 1/4-20 S/S
5	1	104204	DOOR WELDMENT, INNER, S/C 5.1
4	1	104026	GASKET, DOOR S/C 5.1
3	1	104022	PLATE, INNER GASKET RETAINER, S/C 5.1
2	1	104021	PLATE, GASKET RETAINER, S/C 5.1
1	6	104719	BOLT, CARRIAGE 1/4-20 X 1.000"



TOLERANCES (EXCEPT AS NOTED)		CLEVELAND RANGE INC. 1333 East 179th St. Cleveland, Ohio 44110-2574	
DECIMAL ± -	SCALE NONE	DRAWN BY JPB	APPROVED BY
ANGULAR ± 1'	TITLE DOOR, INNER ASSY. STEAMCRAFT 5.1		
AC	DATE 6/25/91	DRAWING NO. B- 104202	REV A

THIS DESIGN DESCRIBES A PROPRIETARY ITEM AND IS THE PROPERTY OF CLEVELAND RANGE.
THIS DRAWING IS NOT TO BE COPIED OR USED WITHOUT THE APPROVAL OF CLEVELAND RANGE

LET.	REVISIONS	DATE	BY
A	ADDED P/N 106143 & P/N 18357 WAS QTY. OF 6 PER EO #C-2303	10/07/92	PD

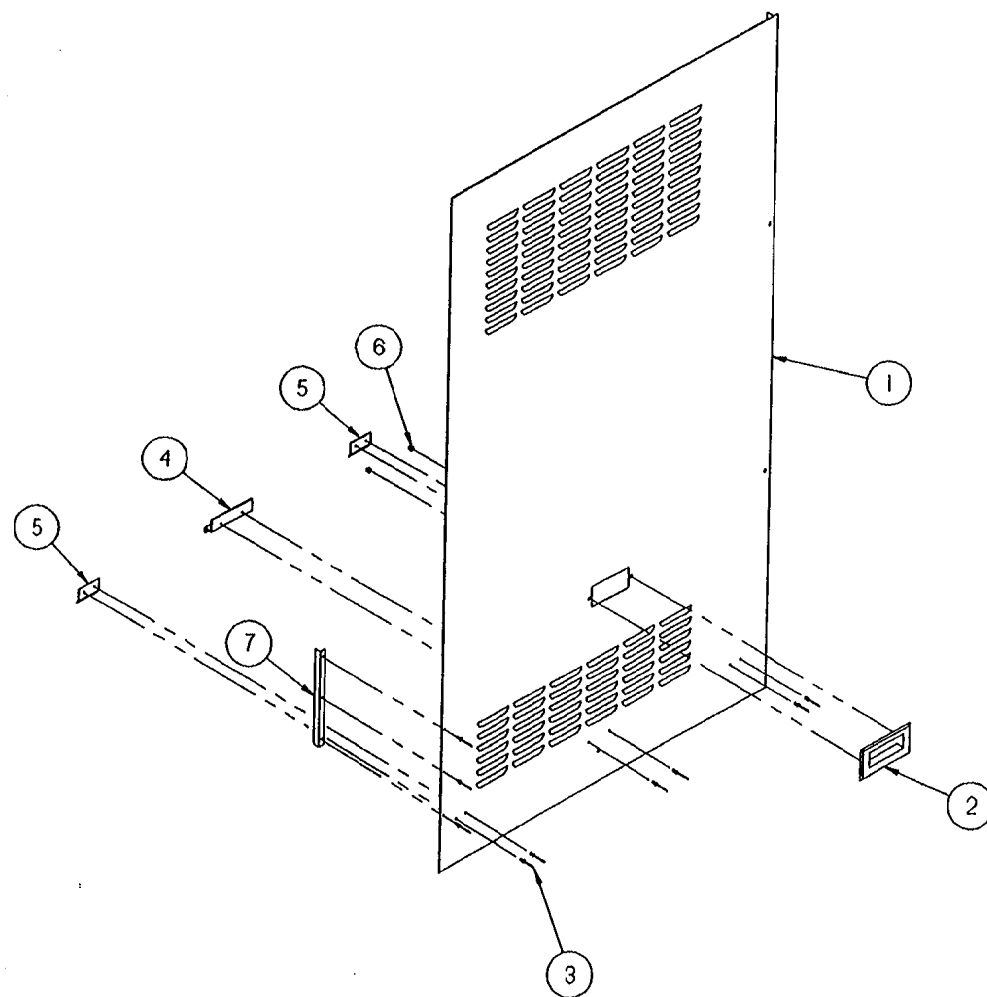

△	7	1	106143	ANGLE, REINFORCEMENT
	6	2	14676	NUT, ACORN 10-32 S/S
	5	2	106045	BRACKET, SIDE SUPPORT, SHT.
	4	1	106044	BRACKET, SIDE SUPPORT, LG.
△	3	9	18357	RIVET, FLUSH 1/8 S/S
	2	1	08108	HANDLE, DOOR, S/S
	1	1	105668	PANEL, SIDE, RIGHT, SC 10
	ITEM	QTY.	PART NO.	DESCRIPTION

TOLERANCES
(EXCEPT AS NOTED)

CLEVELAND RANGE INC.
1333 East 179th St. Cleveland, Ohio 44110-2574

DECIMAL ± N/A	SCALE 1/8 = 1	DRAWN BY DUTCHMAN	APPROVED BY BEDFORD
------------------	------------------	----------------------	------------------------

ANGULAR ± N/A	TITLE PANEL, SIDE, RIGHT, ASSY. STEAMCRAFT 10
------------------	---

CK	DATE 09-01-92	DRAWING NO. B - 106042	REV. A
----	------------------	---------------------------	-----------

THIS DESIGN DESCRIBES A PROPRIETARY ITEM
AND IS THE PROPERTY OF CLEVELAND RANGE.
THIS DRAWING IS NOT TO BE COPIED OR USED
WITHOUT THE APPROVAL OF CLEVELAND RANGE.

LET.	REVISIONS	DATE	BY
A	ADDED P/N 106143 & P/N 18357 WAS QTY. OF 6 PER EO #C-2303	10/07/92	PD

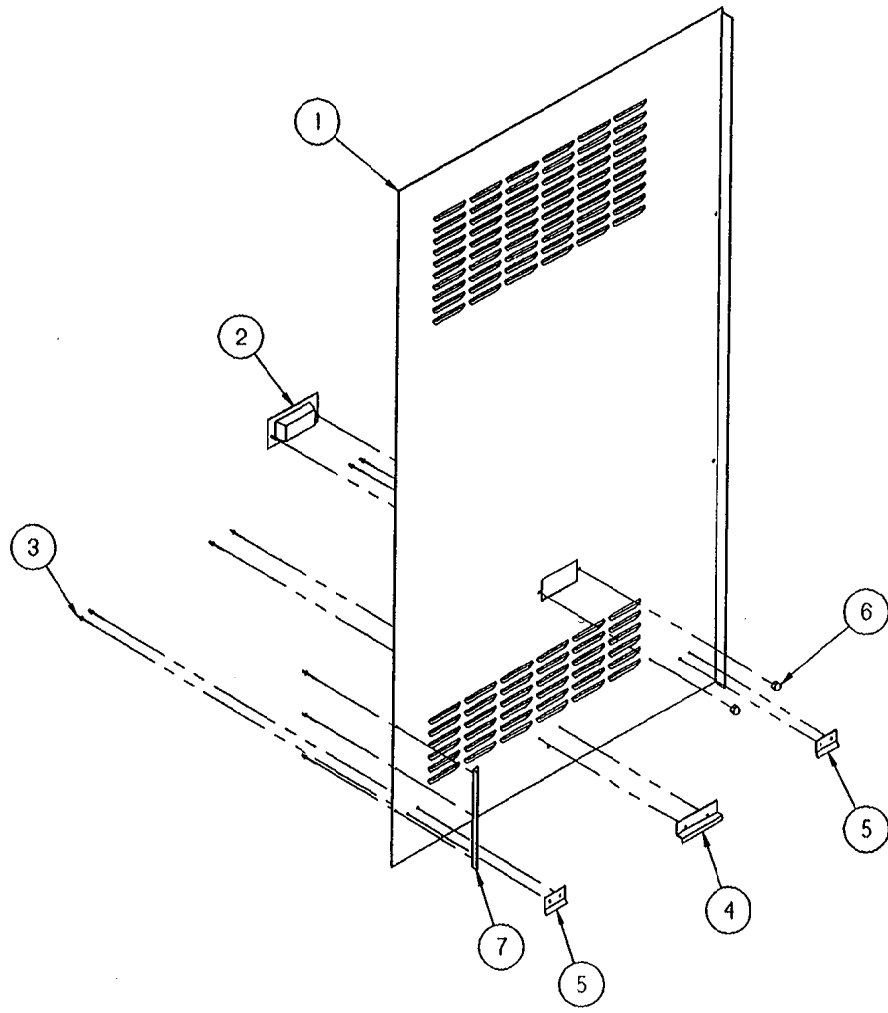

ITEM	QTY.	PART NO.	DESCRIPTION
7	1	106143	ANGLE, REINFORCEMENT
6	2	14676	NUT, ACORN 10-32, S/S
5	2	106045	BRACKET, SIDE SUPPORT, SHT.
4	1	106044	BRACKET, SIDE SUPPORT, LG.
3	9	18357	RIVET, FLUSH 1/8 S/S
2	1	08108	HANDLE, DOOR, S/S
1	1	105669	PANEL, SIDE, LEFT, SC 10

TOLERANCES (EXCEPT AS NOTED)		CLEVELAND RANGE INC. 1333 East 179th St. Cleveland, Ohio 44110-2574	
DECIMAL ± N/A	SCALE 1/8 = 1	DRAWN BY DUTCHMAN	APPROVED BY BEDFORD
ANGULAR ± N/A	TITLE PANEL, SIDE, LEFT, ASSY. STEAMCRAFT 10		
CK	DATE 09-01-92	DRAWING NO. B - 106043	REV. A

THIS DESIGN DESCRIBES A PROPRIETARY ITEM AND IS THE PROPERTY OF CLEVELAND RANGE. THIS DRAWING IS NOT TO BE COPIED OR USED WITHOUT THE APPROVAL OF CLEVELAND RANGE.

STEAMCRAFT 10 - ELECTRIC ELECTRONIC TIMER

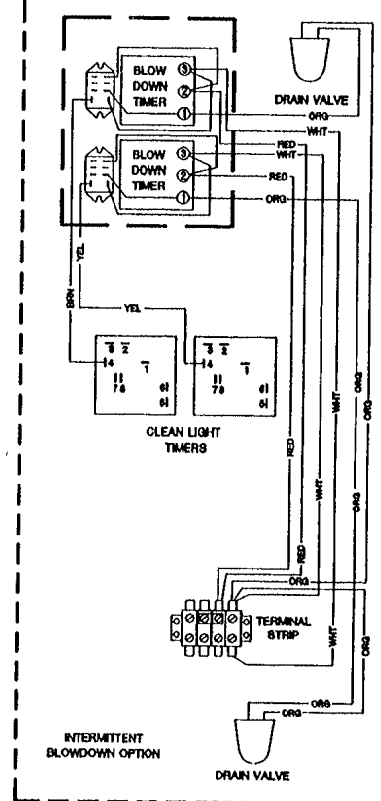
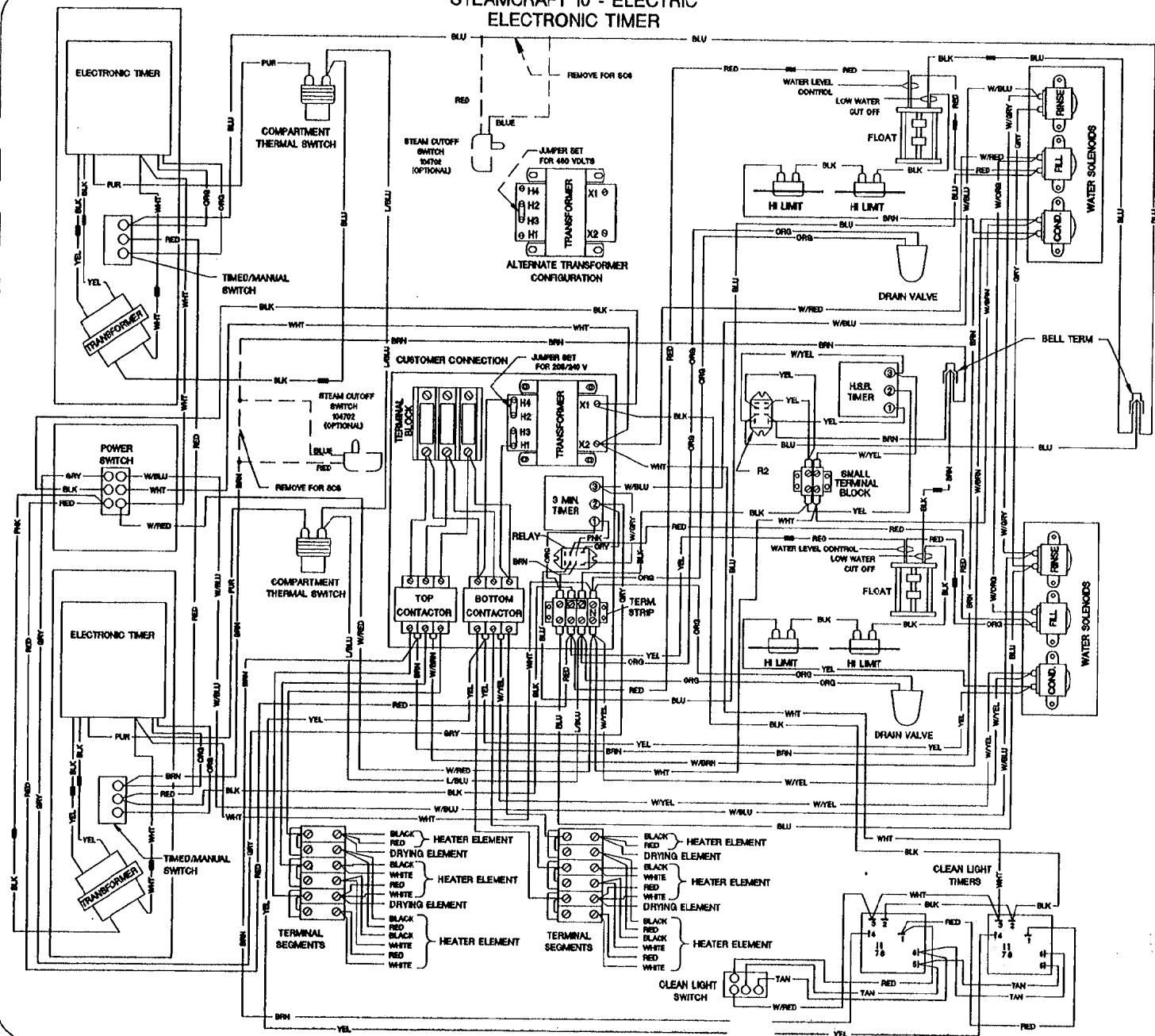

PARTS LIST

- POWER TRANSFORMER - 03549
- RELAYS - 105966
- TERMINAL BLOCK - 02193
- TERMINAL SEGMENT - 101641
- TERMINAL STRIP - 02192
- TIMER TRANSFORMER - 04390
- TIME/MANUAL SWITCH - 04224
- WATER SOLENOID - 22216
- INT. BLOWDOWN TIMER - 106541
- CLEAN LIGHT SWITCH - 19994
- CLEAN LIGHT TIMERS - 198911
- 3 MINUTE TIMER - 20478
- COMPARTMENT T'STAT - 19972
- CONTACTOR - 03549
- DRAIN VALVE - 22244
- ELECTRONIC TIMER - 104389
- FLOAT - 103728
- HI LIMIT - 105731
- PREHEAT THERMOSTAT - 105789
- POWER SWITCH - 19993
- H.S.B. TIMER - 106247
- BELL TERMINALS - 100847

STEAMCRAFT 10 - ELECTRIC MECHANICAL TIMER

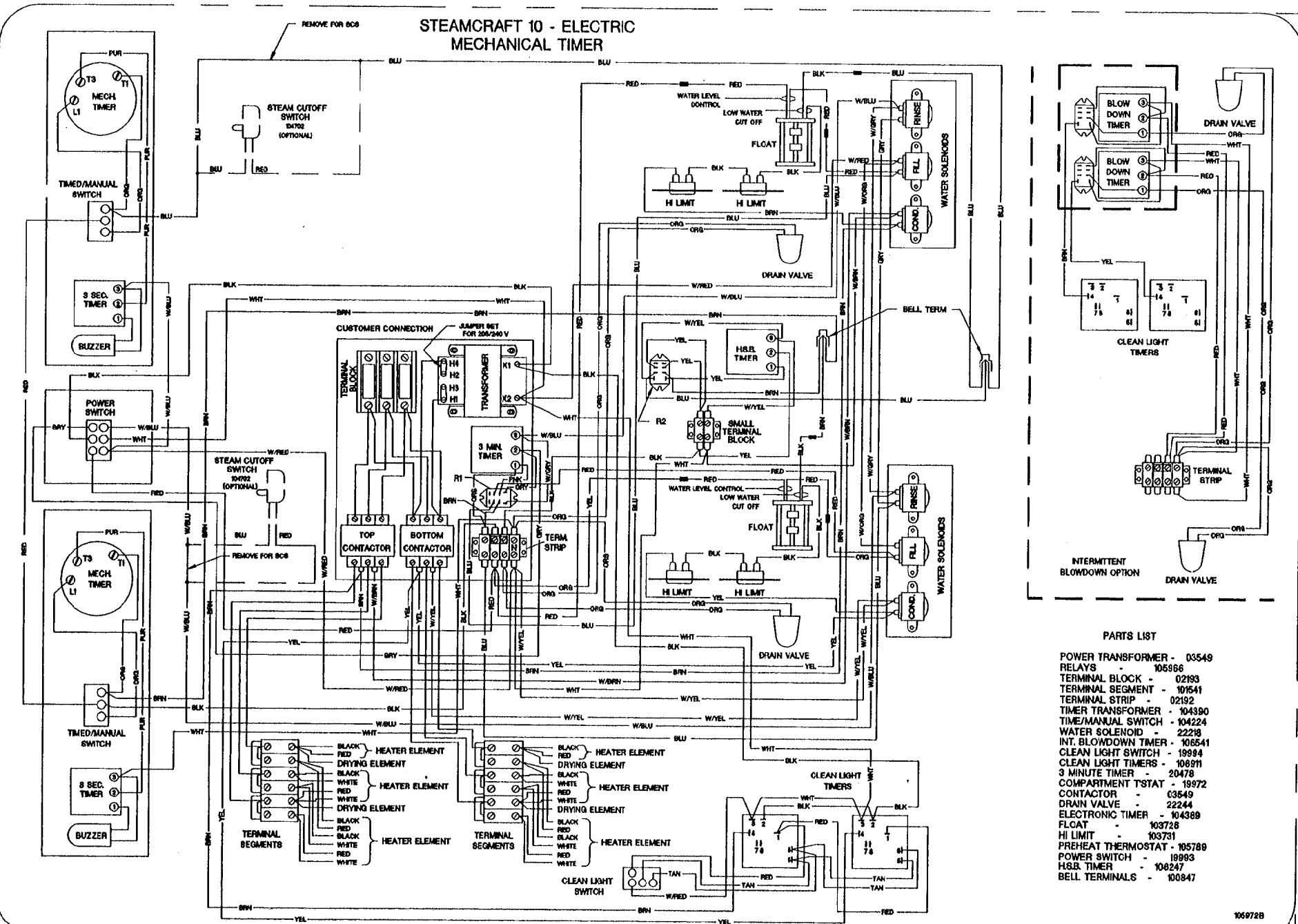

PARTS LIST

- POWER TRANSFORMER - 03549
- RELAYS - 105966
- TERMINAL BLOCK - 02193
- TERMINAL SEGMENT - 101541
- TERMINAL STRIP - 02192
- TIMER TRANSFORMER - 104390
- TIME/MANUAL SWITCH - 104224
- WATER SOLENOID - 22218
- INT. BLOWDOWN TIMER - 106541
- CLEAN LIGHT SWITCH - 19984
- CLEAN LIGHT TIMERS - 108911
- 3 MINUTE TIMER - 20478
- COMPARTMENT T'STAT - 19972
- CONTACTOR - 03549
- DRAIN VALVE - 22244
- ELECTRONIC TIMER - 404369
- FLOAT - 103738
- HI LIMIT - 103731
- PREHEAT THERMOSTAT - 105789
- POWER SWITCH - 18993
- HSB. TIMER - 108247
- BELL TERMINALS - 100847

STEAMCRAFT 10 - ELECTRIC ON/OFF SWITCH

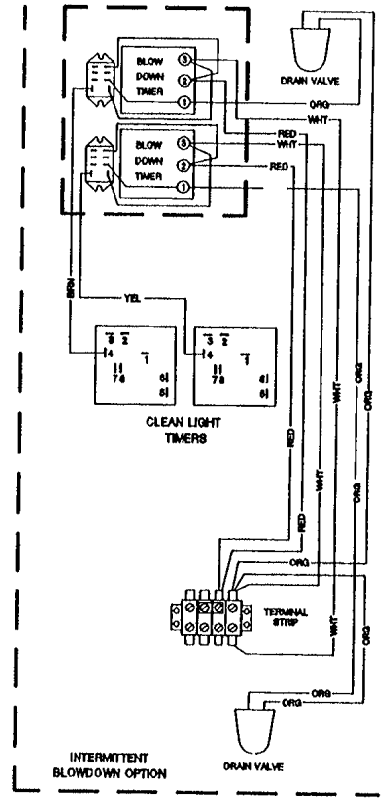
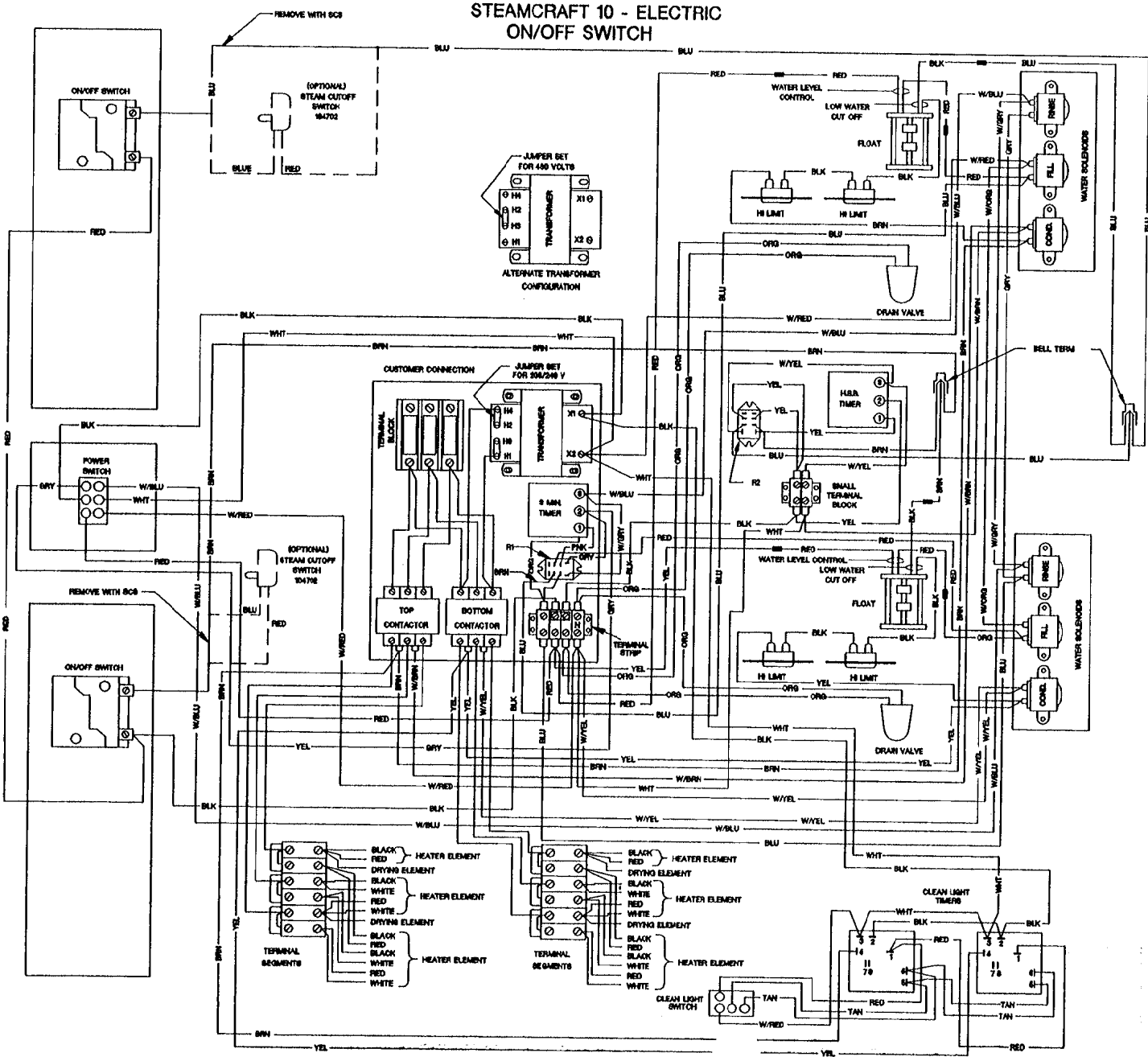

- PARTS LIST**
- POWER TRANSFORMER - 03549
 - RELAYS - 105988
 - TERMINAL BLOCK - 02193
 - TERMINAL SEGMENT - 101541
 - TERMINAL STRIP - 02192
 - TIMER TRANSFORMER - 104390
 - TIME/MANUAL SWITCH - 104224
 - WATER SOLENOID - 103541
 - INT. BLOWDOWN TIMER - 22216
 - CLEAN LIGHT SWITCH - 18984
 - CLEAN LIGHT TIMERS - 106911
 - 3 MINUTE TIMER - 20478
 - COMPARTMENT T'STAT - 18972
 - CONTACTOR - 03549
 - DRAIN VALVE - 22244
 - ELECTRONIC TIMER - 104389
 - FLOAT - 103726
 - HI LIMIT - 103731
 - PREHEAT THERMOSTAT - 105789
 - POWER SWITCH - 18993
 - H.S.B. TIMER - 106247
 - BELL TERMINALS - 100847

Statement of Responsibilities

This document is for use by experienced and trained Qualified Cleveland Range, LLC Authorized Service Representatives who are familiar with both the safety procedures, and equipment they service.

Cleveland Range, LLC assumes no liability for any death, injury, equipment damage, or property damage resulting from use of, improper use of, or failure to use the information contained in this document.

Cleveland Range, LLC has made every effort to provide accurate information in this document, but cannot guarantee that this document does not contain unintentional errors and omissions.

The information in this document may be subject to technical and technological changes, revisions, or updates.

Cleveland Range, LLC assumes no liability or responsibility regarding errata, changes, revisions, or updates.

Qualified Cleveland Range, LLC Authorized Service Representatives are obligated to follow industry standard safety procedures, including, but not limited to, OSHA regulations, and disconnect / lock out / tag out procedures for all utilities including steam, and disconnect / lock out / tag out procedures for gas, electric, and steam powered equipment and / or appliances

All utilities (gas, electric, water and steam) should be turned OFF to the equipment and locked out of operation according to OSHA approved practices during any servicing of Cleveland Range equipment

Qualified Cleveland Range, LLC Authorized Service Representatives are obligated to maintain up-to-date knowledge, skills, materials and equipment.

SteamCraft® Ultra 10

TWO COMPARTMENT FLOOR MODEL DESIGN
PRESSURELESS CONVECTION STEAMER
Twin Electric Steam Generators, 16 KW each

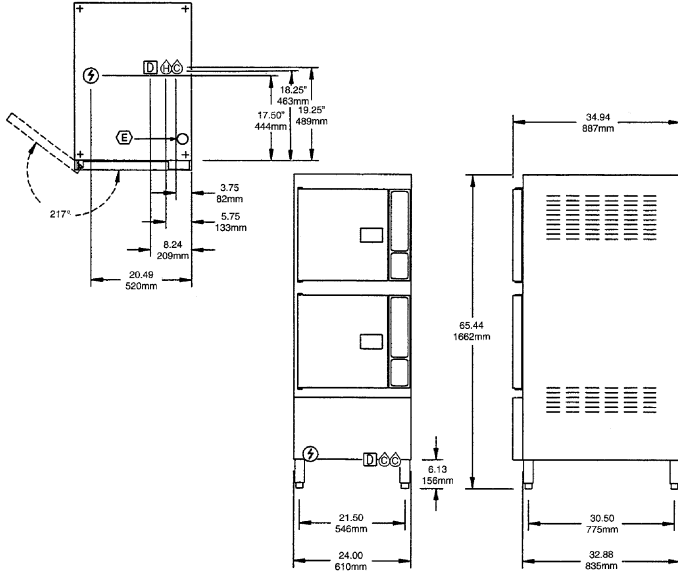

MODEL: 24-CEA-10

ITEM NUMBER _____

JOB NAME / NUMBER _____

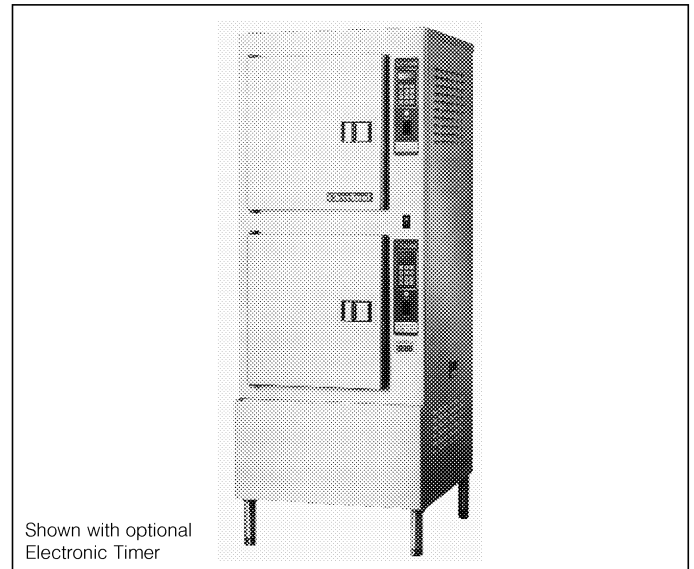

Shown with optional Electronic Timer

SHORT FORM SPECIFICATION

Shall be Two Compartments, Cleveland Convection Steamer series **SteamCraft® Ultra 10**, Model 24-CEA-10, Twin Electric Atmospheric Steam Generator, 32 KW input. Remote Probe Type Water Level Controls. Steam Generator with Automatic Water Fill on start up. Automatic Generator Blowdown, Two each 16.5 KW Fire Bar Heating Elements. Choice of Compartment Controls, Manual By Pass Operation Mode, Compensating Thermostat, Patented Cold Water Condenser design, Type 430 Stainless Steel exterior and cooking compartments.

UTILITY CONNECTIONS		
(A) Electrical Supply	(D) Drain: 1.50" (38mm) Dia.	
(B) Cold Water Supply for Condenser 3/8" Dia. IPS	(E) Inlet for Generator Delimiting Solution	
(C) Cold Water Supply for Generator and Water Injection. 3/8" Dia. IPS (for water treatment conn.) Unit comes with a 50 Mesh Water Strainer (installation required)		
TOTAL CAPACITY (2 Compartments)		
10 — 12" x 20" x 2 1/2" Cafeteria Pans or 20 — 12" x 20" x 1" Cafeteria Pans or 6 — 12" x 20" x 4" Cafeteria Pans		
ELECTRIC ⚡		COLD WATER Ⓒ
STANDARD ELECTRIC		35 psi minimum 60 psi maximum Ⓒ 3/8" Dia. IPS for Generator (for water treatment connection) Ⓒ 3/4" Dia. IPS for Condenser
VOLTS	KW	
208	32	
220	30	
240	36	
440	30	
480	36	
LOW WATTAGE OPTION		
VOLTS	KW	3PH AMPS
208	16.5	46
220	15	40
240	18	44
440	15	20
480	18	22
DRAINAGE (D)		CLEARANCE
1 1/2" Dia. Do not connect other units to this drain. Drain line must be vented. No PVC pipe for drain.		Right - 6.00" Left - 3.00" Rear - 3.00"

WATER QUALITY REQUIREMENT

The quality of water varies greatly from region to region. Steam equipment must be blown down daily and chemically descaled periodically to ensure proper operation. To minimize service problems caused by the accumulation of minerals and chemicals in water, review the following quality guidelines with a local water treatment specialist. Inlet water that is beyond these specified guidelines should be treated to achieve the acceptable limits.

TOTAL DISSOLVED SOLIDS	less than 60 parts per million
TOTAL ALKALINITY	less than 20 parts per million
SILICA	less than 13 parts per million
pH FACTOR	greater than 7.5
CHLORINE	less than 30 parts per million

A typical water quality analysis can be secured from your local water district. Water that is potable does not guarantee compatibility with steam equipment. Try **SteamerGard** for factory authorized water.

Cleveland Range reserves right of design improvement or modification, as warranted.

CLEVELAND RANGE 24CEA10
SEQUENCE OF OPERATIONS
Mechanical Timer

1. Supply power is sent to the primary of the main transformer.
 - 115 VAC is sent from the secondary of the main transformer to the on/off rocker,
2. To turn the unit on, depress the red on/off rocker switch.
 - 115 VAC is sent to the red indicator light.
 - 115 VAC is sent to both coils of the normally open drain valves closing them.
 - 115 VAC is sent to the H and N terminals of both water level boards.
3. With the water level board energized and no water in the generators
 - After a 5 second delay, 115 VAC is sent from the FILL terminals to the fill solenoids.
 - The fill solenoids open and the generators fill through the drain valves until the high probe is grounded (see step 4).
 - The water fills to the low probe in each probe assembly shorting it to ground
 - 115 VAC is sent from the HEAT terminals of the water level board to the timed manual switches.
 - 115 VAC is sent to the heat standby timer which will energize the R2 relay coil 3 seconds every 4 minutes
 - The normally open contacts of the R2 relay close bypassing the timed/manual switch to maintain heat while unit is idle
4. For each compartment, when the timed/manual switch is in the manual position or timed position with time on the timer
 - 115 VAC is sent from the timer to the coil of the R5 relay for the top compartment
 - The R5 relay energizes
 - R5B contacts close sending 115 VAC to the motor timer
 - R5A contacts close sending 115 VAC through the optional door switch to the normally closed contacts of the high limits
 - 115 VAC is then sent through the high limits to the coil of condensate solenoid and the coil of the contactor.
 - 115 VAC is sent to the clean light timer.
 - When the clean light timer times down 115 VAC is sent to the clean light switch.
 - When the clean light switch is depressed the timer is reset.
 - When the contactor is energized supply voltage is sent to both of the elements.
 - 115 VAC is sent from the timer to the coil of the R6 relay for the bottom compartment
 - The R6 relay energizes
 - R6B contacts close sending 115 VAC to the motor timer
 - R6A contacts close sending 115 VAC through the optional door switch to the normally closed contacts of the high limits
 - 115 VAC is then sent through the high limits to the coil of condensate solenoid and the coil of the contactor.

- 115 VAC is sent to the clean light timer.
 - When the clean light timer times down 115 VAC is sent to the clean light switch.
 - When the clean light switch is depressed the timer is reset.
 - When the contactor is energized supply voltage is sent to both of the elements.
 - When the mechanical timer times out 115 VAC is sent to the 3-second timer and then to the buzzer for 3 seconds.

- 5. When the water level reaches the high probe then 115 VAC is removed from the FILL terminal and the fill solenoid is turned off.

- 6. After the water level drops below the high probe for 5 seconds 115 VAC is sent to the FILL terminal again.

- 7. The red 115 VAC switch is depressed and the unit is turned off.
 - 115 VAC is removed from the timer and heat circuits.
 - 115 VAC is removed from the normally open drain valves allowing the steamer to drain.
 - 115 VAC is sent to the 3-minute timer and the R1 relay coil is energized.
 - The normally open contacts of the R1 relay will close
 - The fill solenoids are then energized for 3 minutes flushing the drains.

STEAMCRAFT-10 ELECTRIC MECHANICAL TIMER

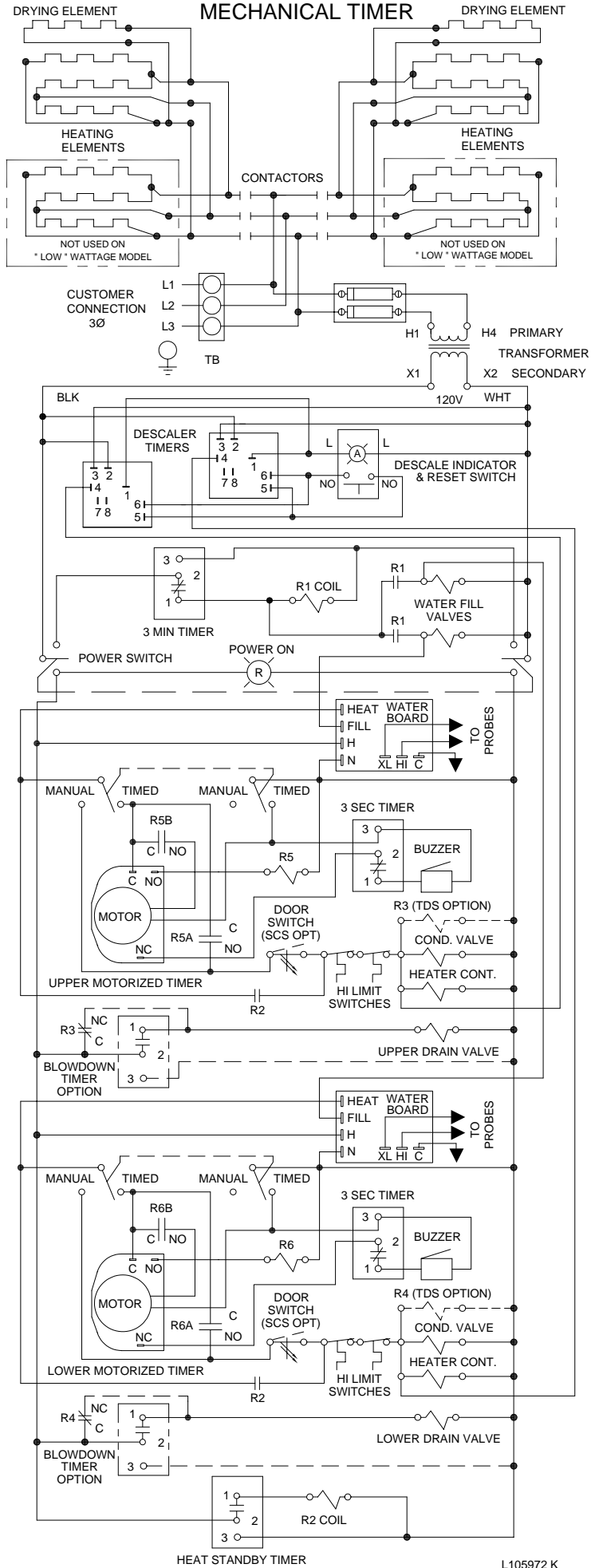

STEAMCRAFT 10 - ELECTRIC MECHANICAL TIMER

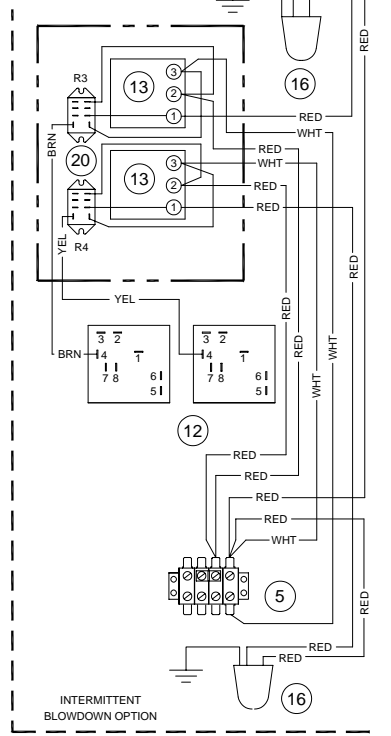
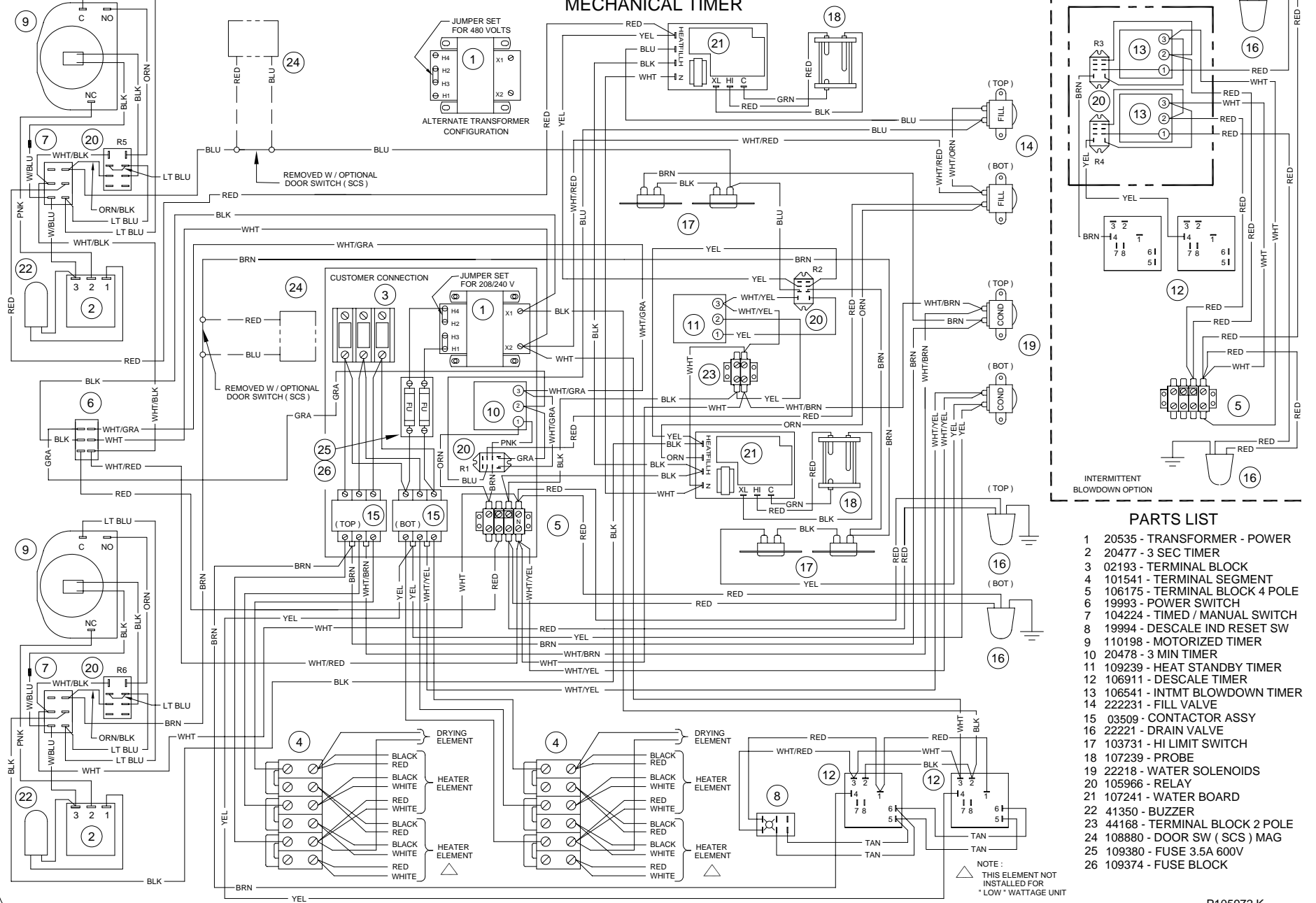

- ### PARTS LIST
- 1 20535 - TRANSFORMER - POWER
 - 2 20477 - 3 SEC TIMER
 - 3 02193 - TERMINAL BLOCK
 - 4 101541 - TERMINAL SEGMENT
 - 5 106175 - TERMINAL BLOCK 4 POLE
 - 6 19993 - POWER SWITCH
 - 7 104224 - TIMED / MANUAL SWITCH
 - 8 19994 - DESCALE IND RESET SW
 - 9 110198 - MOTORIZED TIMER
 - 10 20478 - 3 MIN TIMER
 - 11 109239 - HEAT STANDBY TIMER
 - 12 106911 - DESCALE TIMER
 - 13 106541 - INTMT BLOWDOWN TIMER
 - 14 222231 - FILL VALVE
 - 15 03509 - CONTACTOR ASSY
 - 16 22221 - DRAIN VALVE
 - 17 103731 - HI LIMIT SWITCH
 - 18 107239 - PROBE
 - 19 22218 - WATER SOLENOIDS
 - 20 105966 - RELAY
 - 21 107241 - WATER BOARD
 - 22 41350 - BUZZER
 - 23 44168 - TERMINAL BLOCK 2 POLE
 - 24 108880 - DOOR SW (SCS) MAG
 - 25 109380 - FUSE 3.5A 600V
 - 26 109374 - FUSE BLOCK

NOTE:
THIS ELEMENT NOT
INSTALLED FOR
"LOW" WATTAGE UNIT

**CLEVELAND RANGE 24CEA10
SEQUENCE OF OPERATIONS
Electronic Timer**

1. Supply power is sent to the primary of the main transformer.
 - 115 VAC is sent from the secondary of the main transformer to the on/off rocker,
2. To turn the unit on, depress the red on/off rocker switch.
 - 115 VAC is sent to the red indicator light.
 - 115 VAC is sent to normally open drain valves closing them.
 - 115 VAC is sent to the H and N terminals of both water level boards
 - 115 VAC is sent to both 24VAC transformers for the electronic timers.
 - “PAUS” and the set time are displayed on the timer.
 - 115 VAC is sent to the normally open compartment thermostat switches.
3. With the water level board energized and no water in the generator
 - After a 5 second delay 115 VAC is sent from the FILL terminals on the water boards to the fill solenoids.
 - The fill solenoids open and the generators fill through the drain valves until the high probe is grounded (see step 4).
 - The water fills to the low probe of each probe assembly shorting it to ground
 - 115 VAC is sent from the HEAT terminals of the water boards to the timed manual switches.
 - 115 VAC is sent to the heat standby timer, which will energize the R2 relay 3 seconds every 4 minutes.
 - The normally open contacts of the R2 relay will close to maintain heat while unit is idle
4. For each compartment, when the timed/manual switch is in the timed position and time is on the timer
 - 115 VAC is sent from the timer through the door switch to the normally closed contacts of the high limits
 - 115 VAC is then sent through the high limits to the coil of condensate solenoid and the coil of the contactor.
 - 115 VAC is sent to the clean light timer.
 - When the clean light timer times down 115 VAC is sent to the clean light switch.
 - When the clean light switch is depressed the timer is reset.
 - When the contactor is energized supply voltage is sent to both of the elements.
 - Steam is energized and sent to the cooking compartment.
 - When the cooking compartment reaches 193 degrees the compartment thermostat closes sending 115 VAC to the timer.
 - The timer will stop flashing “PAUS” then begin counting down.
 - When the timer times down a buzzer will sound and the timer will open removing 115 VAC from the heat circuit.

5. When the water level reaches the high probe then 115 VAC is removed from the FILL terminal and the fill solenoid is turned off.
6. After the water level drops below the high probe for 5 seconds 115 VAC is sent to the FILL terminal again.
7. The red 115 VAC switch is depressed and the unit is turned off.
 - 115 VAC is removed from the timer and heat circuit.
 - 115 VAC is removed from the normally open drain valves allowing the steamer to drain.
 - 115 VAC is sent to the 3-minute timer and the coil of the R1 relay is energized for 3 minutes.
 - The normally open contacts of the R1 relay close
 - The fill solenoids are energized for 3 minutes flushing the drain.

STEAMCRAFT-10 ELECTRIC ELECTRONIC TIMER

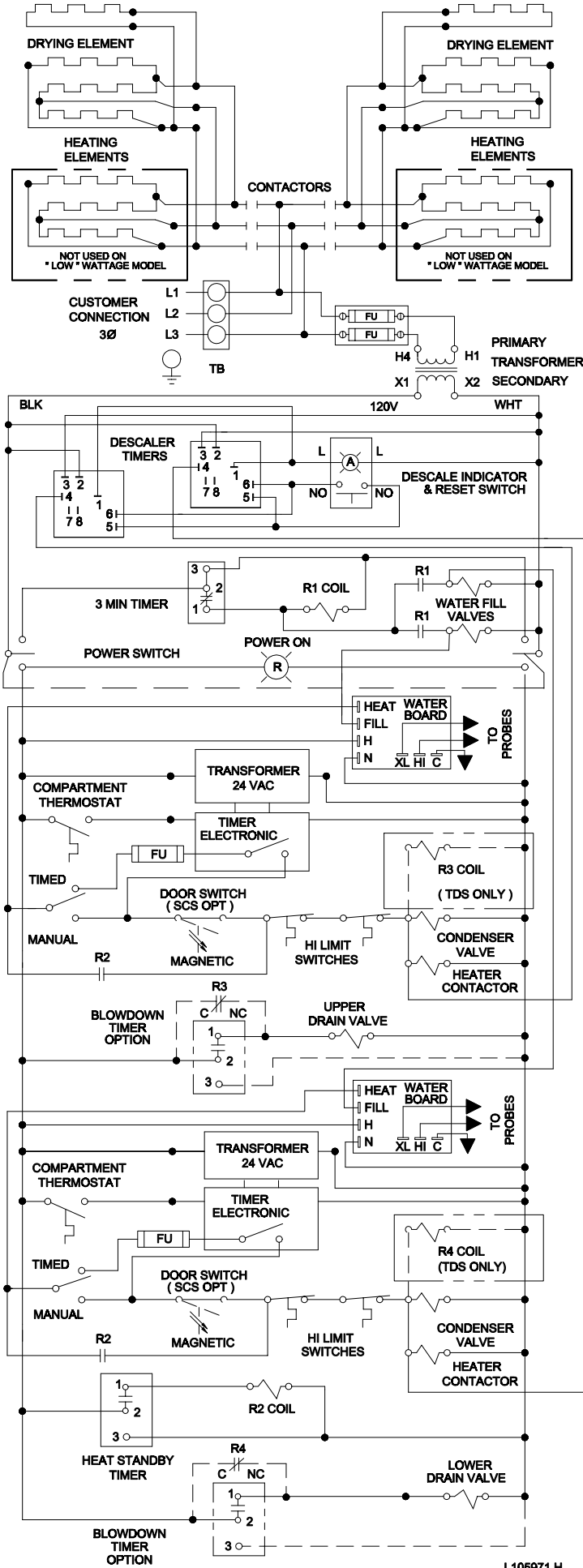

STEAMCRAFT 10 - ELECTRIC ELECTRONIC TIMER

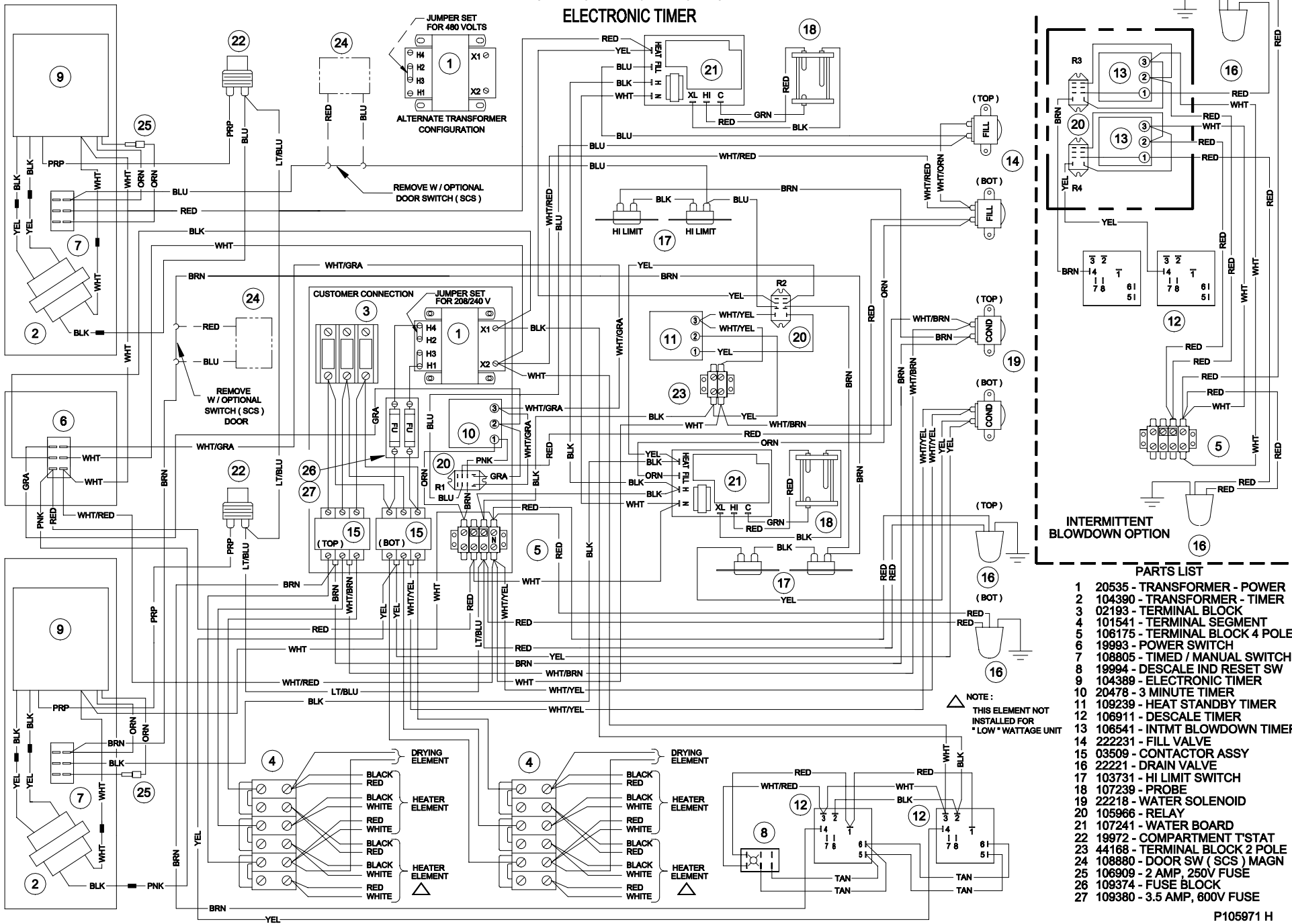

INTERMITTENT BLOWDOWN OPTION

PARTS LIST

- 1 20535 - TRANSFORMER - POWER
- 2 104390 - TRANSFORMER - TIMER
- 3 02193 - TERMINAL BLOCK
- 4 101541 - TERMINAL SEGMENT
- 5 106175 - TERMINAL BLOCK 4 POLE
- 6 19993 - POWER SWITCH
- 7 108805 - TIMED / MANUAL SWITCH
- 8 19994 - DESCALE IND RESET SW
- 9 104389 - ELECTRONIC TIMER
- 10 20478 - 3 MINUTE TIMER
- 11 109239 - HEAT STANDBY TIMER
- 12 106911 - DESCALE TIMER
- 13 106541 - INTMT BLOWDOWN TIMER
- 14 222231 - FILL VALVE
- 15 03509 - CONTACTOR ASSY
- 16 22221 - DRAIN VALVE
- 17 103731 - HI LIMIT SWITCH
- 18 107239 - PROBE
- 19 22218 - WATER SOLENOID
- 20 105966 - RELAY
- 21 107241 - WATER BOARD
- 22 19972 - COMPARTMENT T'STAT
- 23 44168 - TERMINAL BLOCK 2 POLE
- 24 108880 - DOOR SW (SCS) MAGN
- 25 106909 - 2 AMP, 250V FUSE
- 26 109374 - FUSE BLOCK
- 27 109380 - 3.5 AMP, 600V FUSE

NOTE:
THIS ELEMENT NOT
INSTALLED FOR
LOW WATTAGE UNIT

PROBLEM:
21CET8
21CET16
21CEA10
Steamer won't steam.

Steamer won't steam

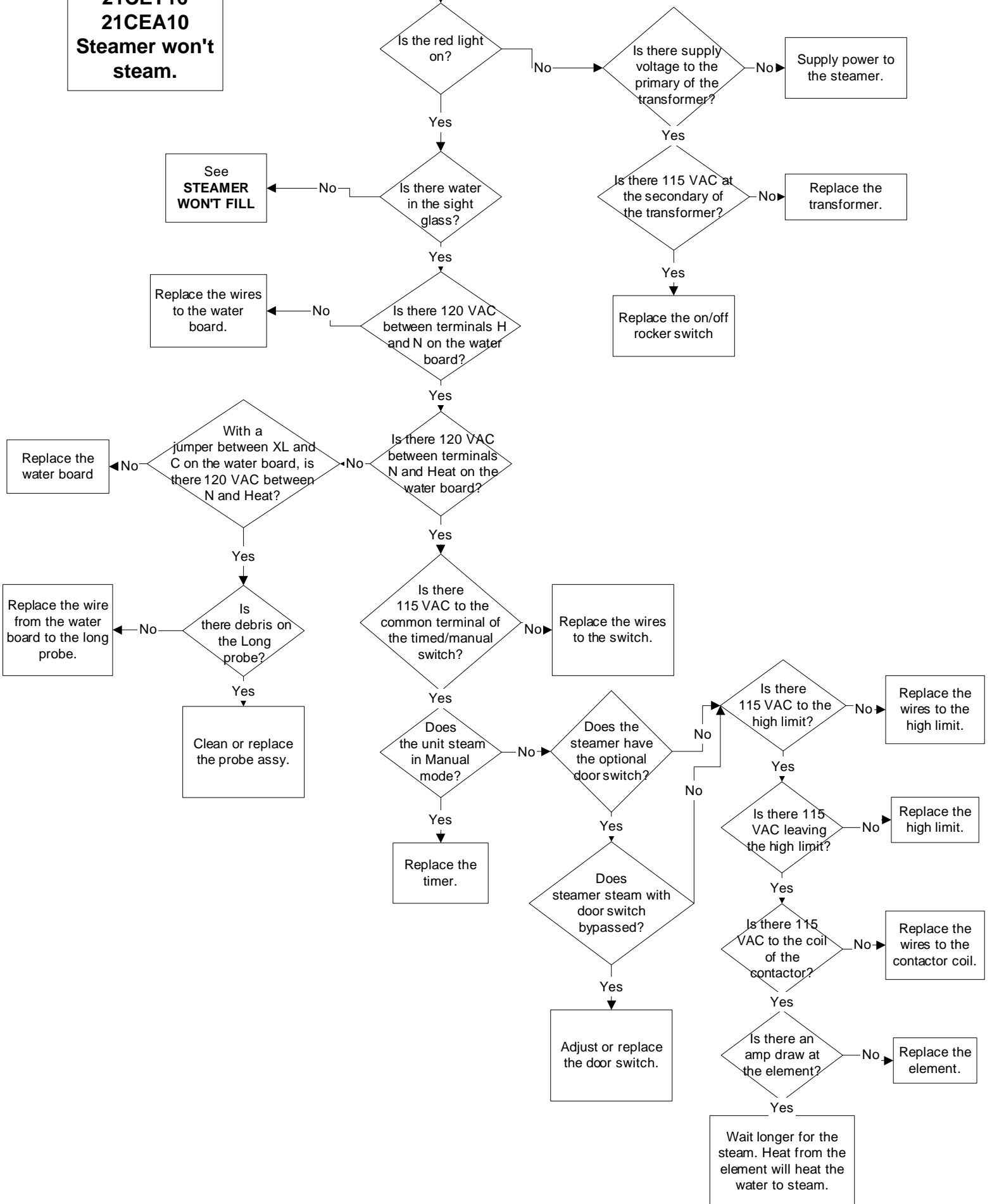

PROBLEM:
21CET8
21CET16
24CEA10
Steamer wont fill

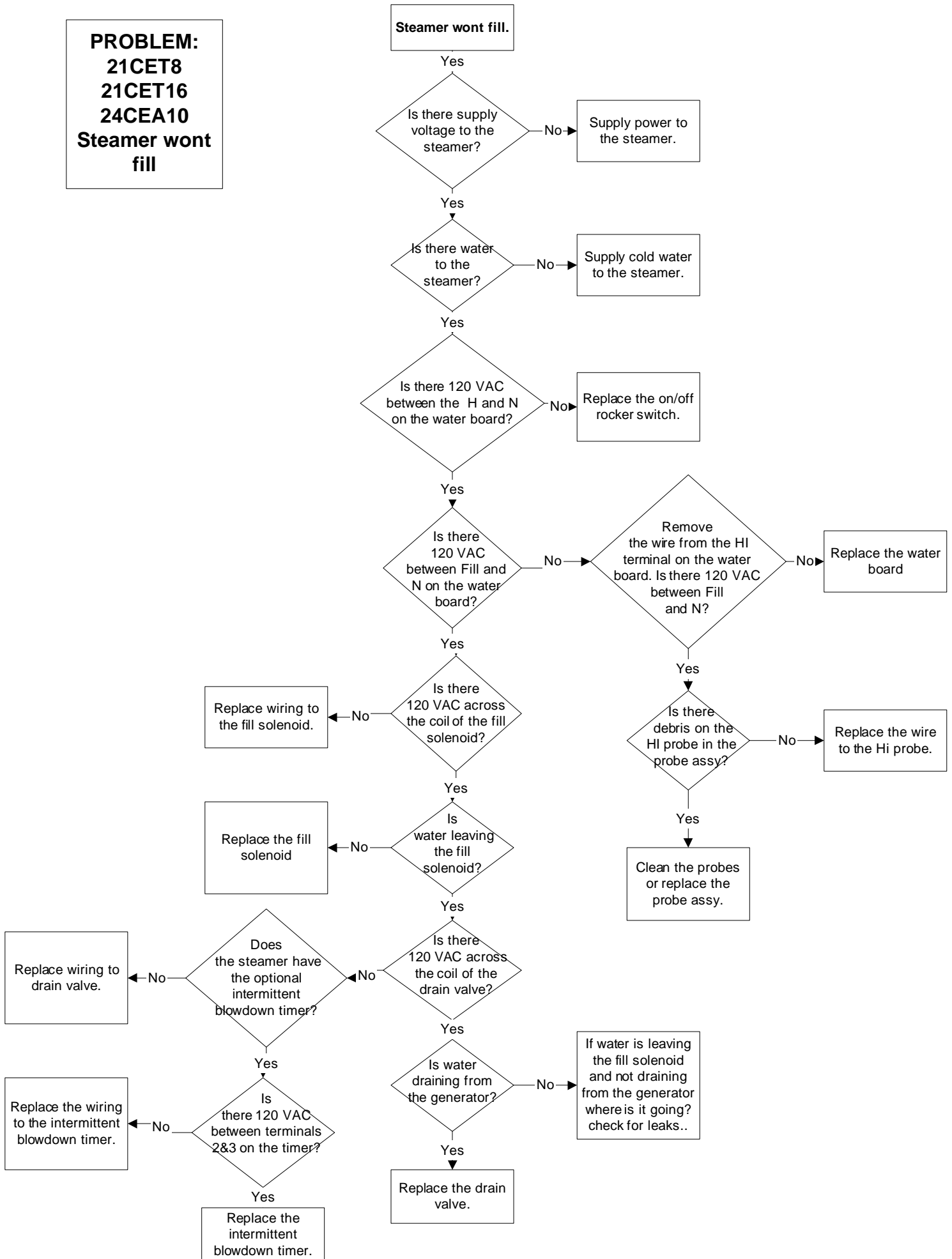

PROBLEM:
21CET8, 21CET16, 24CEA10
Electronic timer displays "PAUS" and won't count down

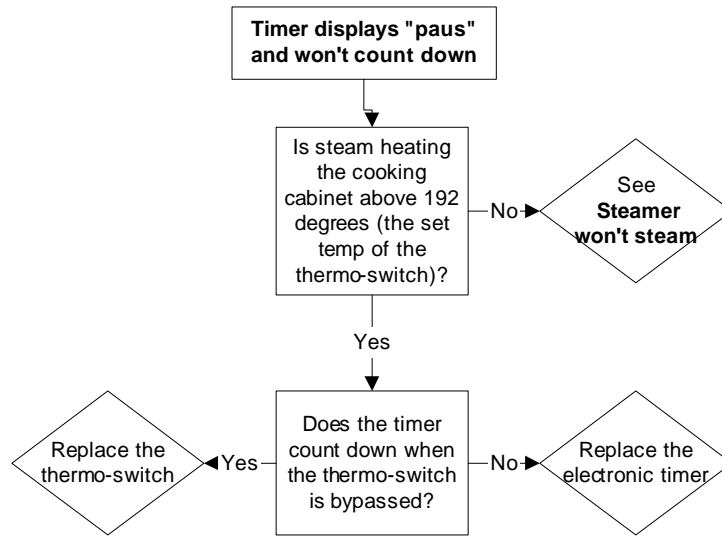

PROBLEM:
21CET8, 21CET16, 24CEA10
Steam leaks around the door.

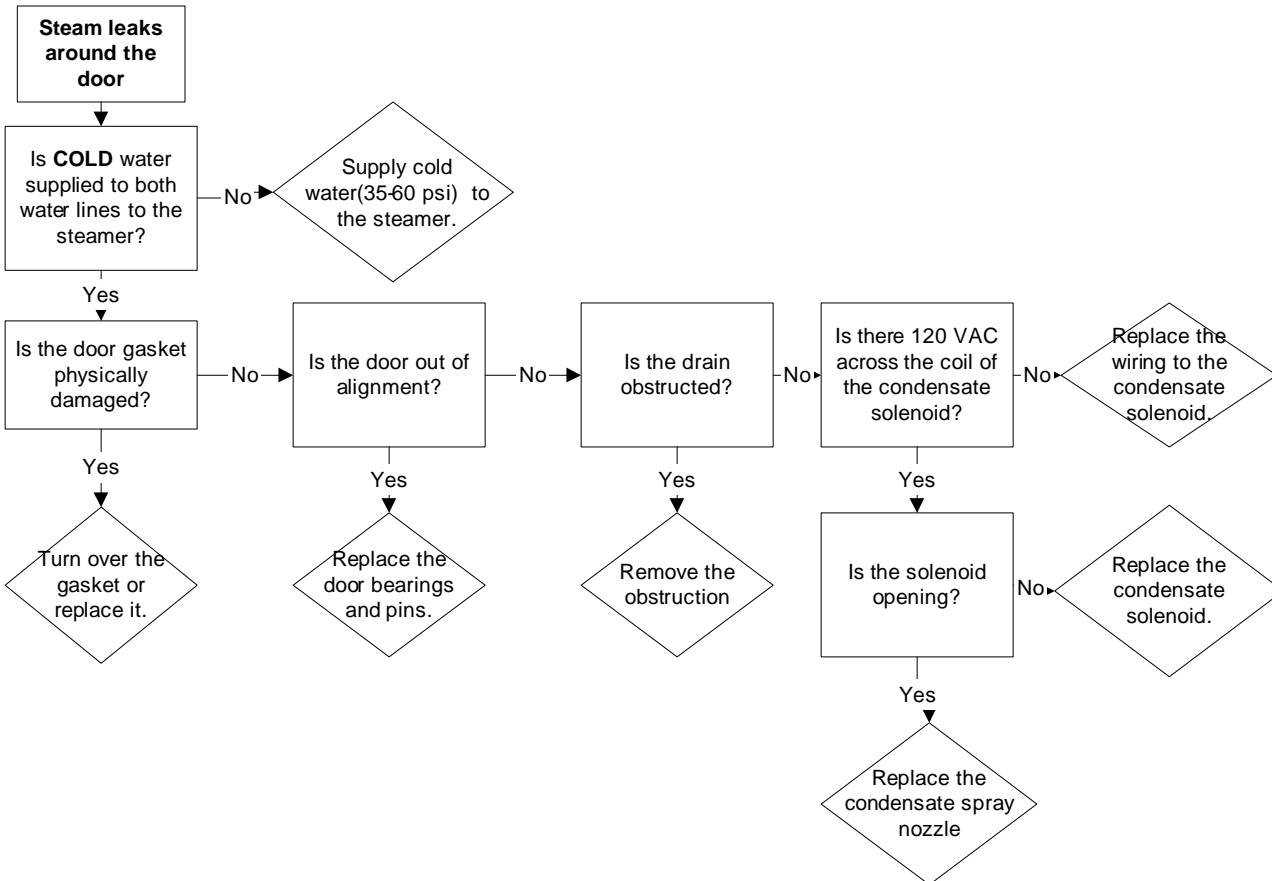

**PROBLEM:
21CET8
21CET16
24CEA10
Steamer overfills.
(Water sprays into cooking cabinet)**

**Steamer overfills
(Water sprays into the cooking cabinet)**

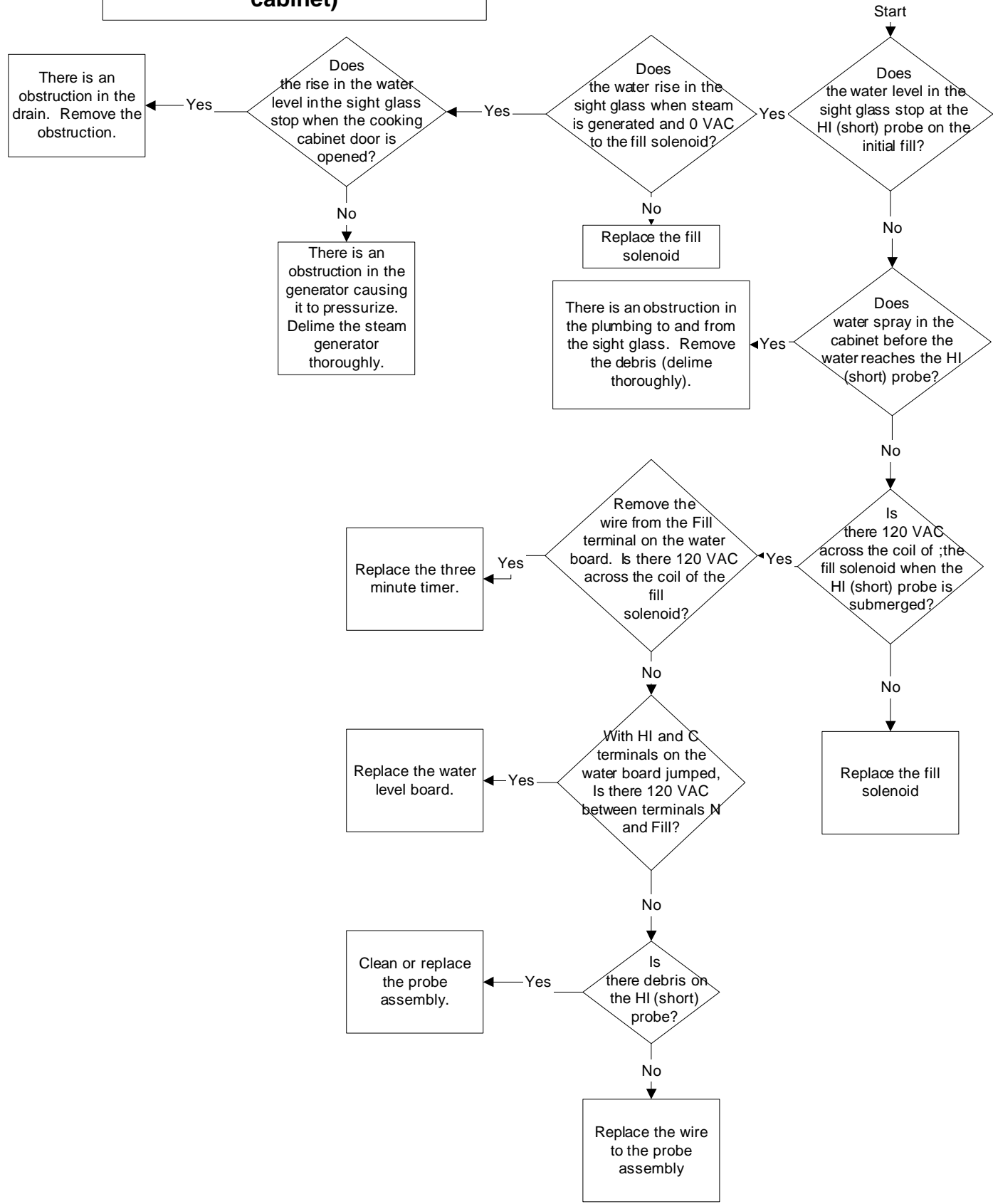

**PROBLEM:
21CET8
21CET16
24CEA10
Steamer won't stop steaming with
door open**

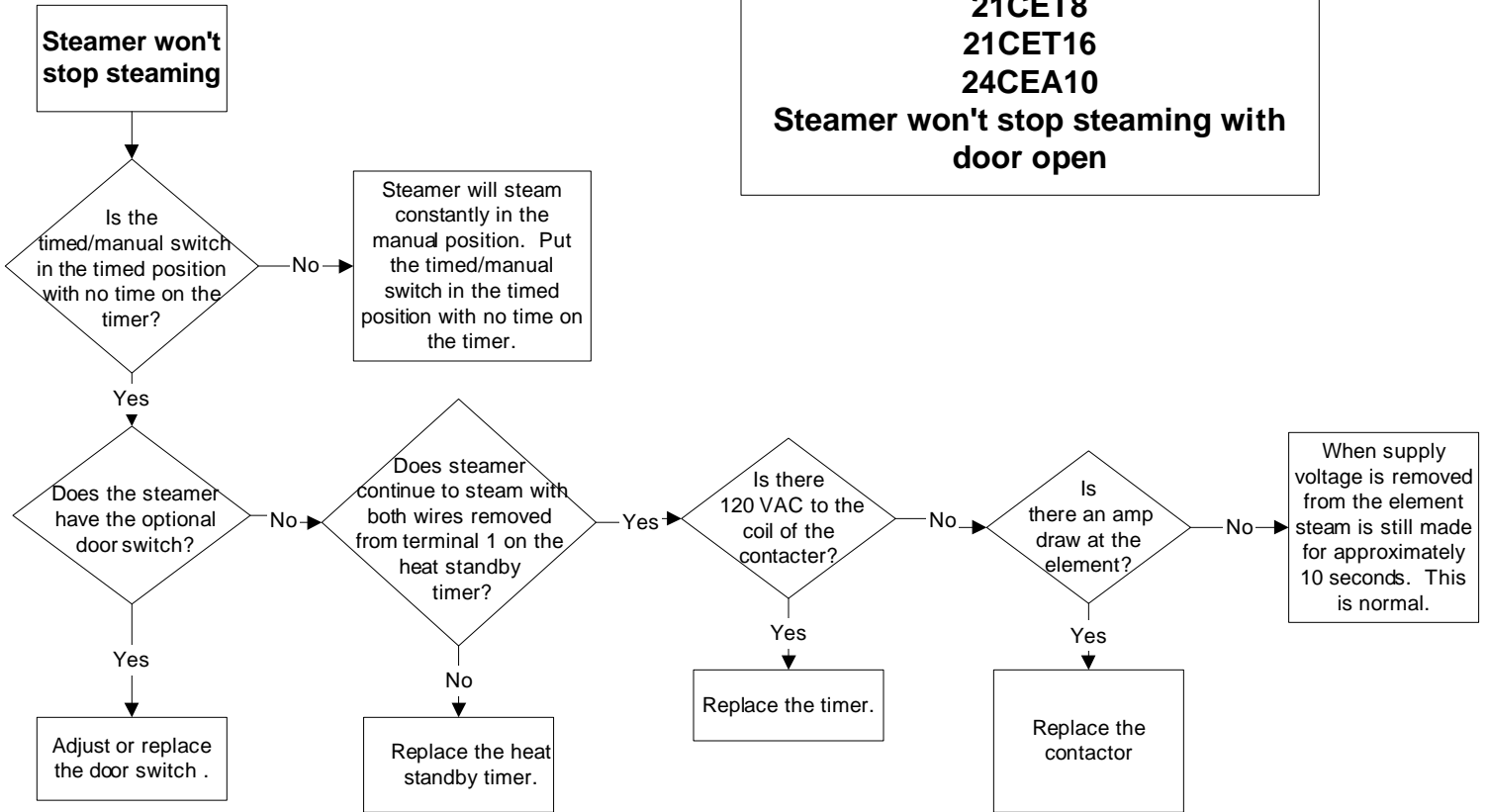

**Problem:
21CET8, 24CEA10
Steamer won't preheat**

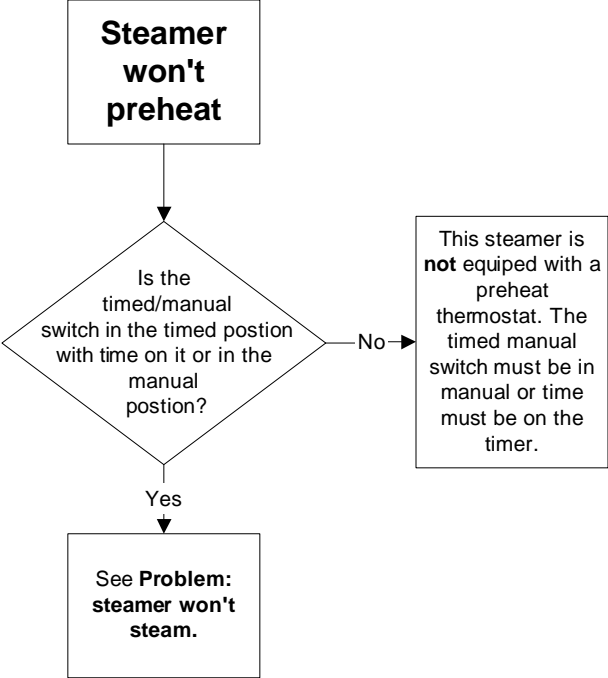

STEAMCRAFT-10 ELECTRIC MECHANICAL TIMER

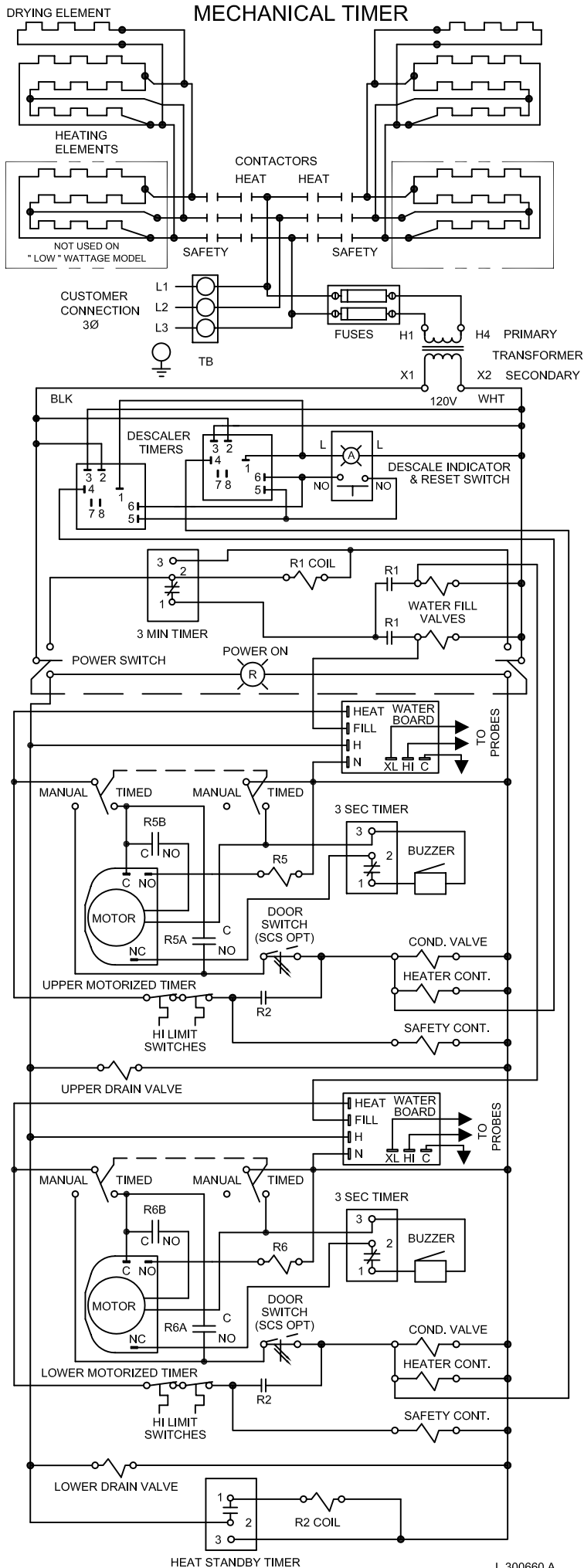



Cleveland

Descaling Procedure-SteamCraft Ultra and Gemini Series

How Much DISSOLVE to Use

Model	Dissolve
Ultra 3	1/2 Gallon
Ultra 5	1 Gallon
Ultra 10 (Elec.)	1 Gallon (ea.)
Ultra 10 (Gas)	1½ Gallon
Gemini 6 & 10	1 Gallon (ea.)

1. Turn the unit OFF and open the doors:

This will drain and rinse the generator for about 3 minutes.

2. Turn the unit power back On:

The generator will begin to refill with water.

3. Select Timed with the Timed/Manual switch:

DO NOT start the timer, since you do not want to heat the water during descaling. Leave the doors open.

4. Remove descaling port cap and add with the specified amount of DISSOLVE: (See chart above)

Do this while the unit is refilling. The generators can take-up to 8 minutes to refill.

5. After refill has stopped, add extra tap water into the descaling port until liquid is seen entering the cooking cabinet. Note: Ultra 10 gas will have liquid coming out of the drain,

Adding extra water when descaling will raise the descaling solution higher than the normal fill level, allowing the DISSOLVE to work on sensors and surfaces above the water line

Note: Some SteamCraft Ultra models (the electric powered Ultra 10 and Gemini 6 and 10, for example) have two generators and two descaling ports. Both units should be descaled at the same time, using this procedure

6. Let the descaler soak in generator for approximately one hour:

7. After one hour, turn the unit power Off: This will drain and rinse the generator for about 3 minutes.



8. After the 3-minute drain cycle completes, turn the unit back ON. After the filling has stopped, add water until liquid enters the cooking compartment (or drain for the ultra 10 gas), and then turn the unit OFF. This will drain and flush any residue from the water level control assembly. Replace descaling cap.

9. After the 3 minute drain cycle completes, Turn the unit ON and set the Timer for 20 minutes: Make sure the Time/Manual switch is in the timed setting and the doors are closed.

10. When the timer times out (after 20 minutes) turn the power Off:

This will drain and rinse the generator for about 3 minutes.

This ends the descaling procedure. You can now turn the unit back on and resume normal startup and cooking operations.