

# Cleveland

## Parts Manual

### PRESSURE STEAMERS



SERIES: PGM, PEM, PSM, PDM, PDL-2/3

## MODELS B, C, F, K PRESSURE STEAMERS DOOR AND DOOR ARM ASSEMBLY

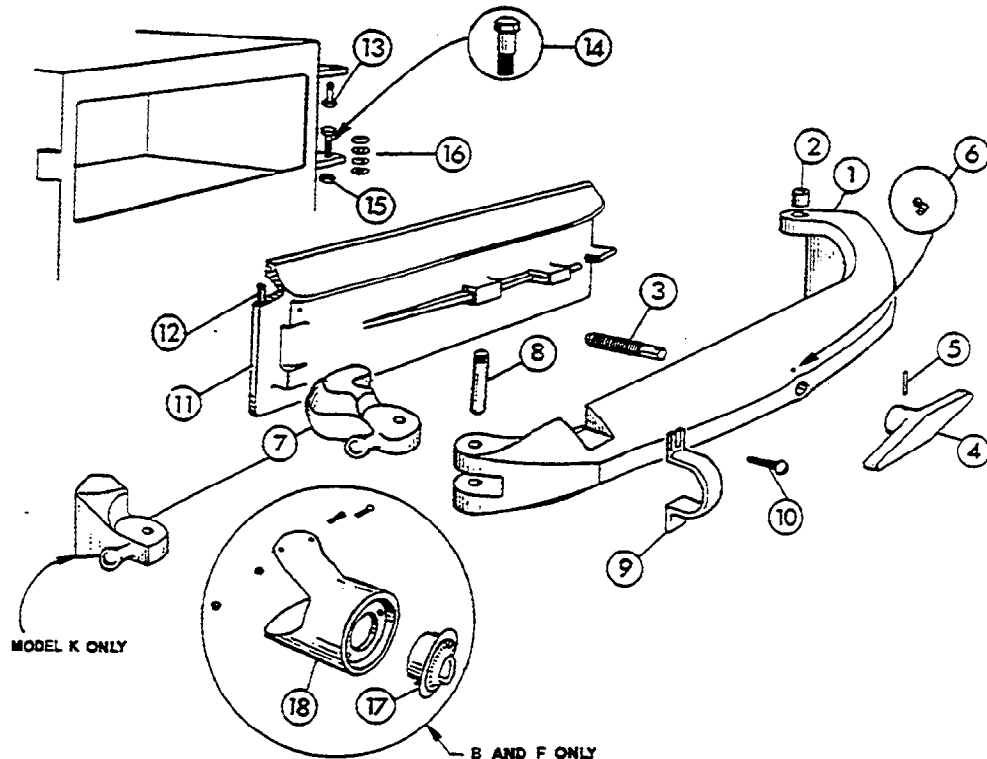

REFERENCE NUMBER	PART NUMBER	DESCRIPTION
1	25303	Door Arm With Bushings — Model B & C, Polished
	25304	Door Arm With Bushings — Model F & K, Polished
2	02568	Door Arm Hinge Bushing (2 Required)
3	41370	Standard Door Arm Screw With Ball (1" x 8 thread)
	41371	Oversize Door Arm Screw With Ball 1½" x 8 thread)
4	081001	Screw Handle Bar, Polished
5	16305	Pin
6	15250	Oil Cup
7	122011	Door Arm Latch — Model B, C, & F Chrome Plated
	122021	Door Arm Latch — Model K Chrome Plated
8	101018	Door Arm Latch Pin — Model B, C, F, & K Brass
	163101	Door Arm Latch Pin — Model B, C, F, & K Chrome Plated
9	081031	Door Retainer — Model B, C, F, & K Chrome Plated
10	<del>19291</del>	Screw
11	041631	Door, Model B Polished
	04164	Door, Model C Polished
	04165	Door, Model F & K Polished
12	07132	Door Gasket — Rubber, Model B
	07134	Door Gasket — Rubber, Model C, F, K
13	023001	Door Arm Hinge Post Bolt (Upper) — Concentric Type —
14	023061	Door Arm Hinge Post Bolt (Lower) — Eccentric Type —
15	14643	Nut, For Lower Hinge Post Bolt
16	23181	Shim Washer
17	40547	60 Minute Bell Timer Assembly
18	08601	Timer Housing — Model B & C Polished (Not Available)
	08606	Timer Housing — Model F Polished (Not Available)

CLEVELAND RANGE CO., 1333 EAST 179th ST., CLEVELAND, OHIO 44110

Manufacturer reserves right of design improvement or modification, as warranted.

## MODEL J DOOR AND DOOR ARM ASSEMBLY

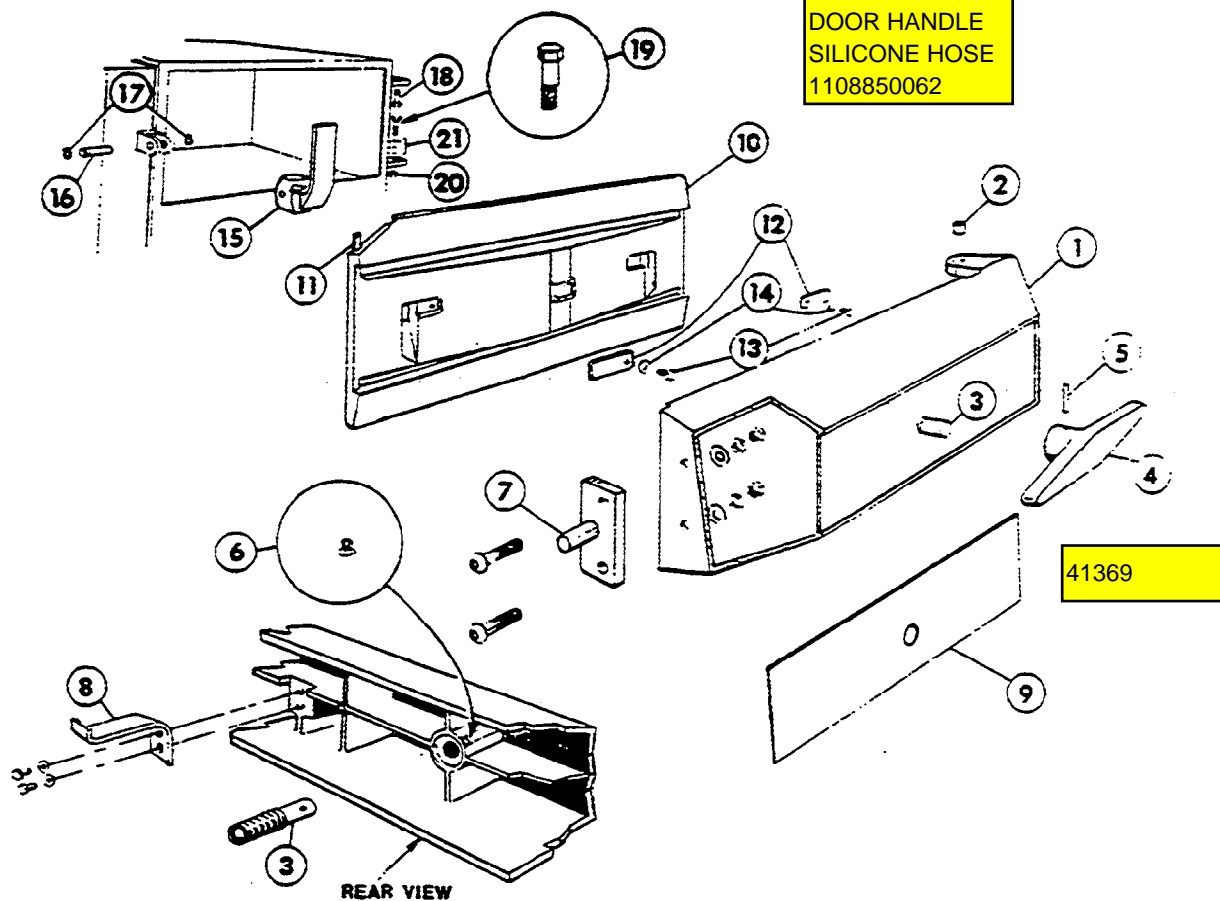

REFERENCE NUMBER	PART NUMBER	DESCRIPTION
1	253022 Door Arm Painted	
2	02568	Door Arm Hinge Bushing (2 Required)
3	41370	Standard Door Arm Screw With Ball (1" x 8 thread)
	41371	Oversize Door Arm Screw With Ball (1 1/32" x 8 thread)
4	081001	Screw Handle Bar, Polished
5	16305	Pin
6	15250	Oil Cup
7	41360	Striker Plate and Pin.
8	43723	Door Hanger w/Screws and Washers (2 Required)
9	53035	Door Arm Insert, Stainless
10	04162	Polished Aluminum Door, 041623 Door Painted
11	07136	Door Gasket — Rubber
12	68140	Retainer, Yoke Hanger (2 Required)
13	19228	Screw
14	23182	Washer
15	122001	Door Arm Latch, Chrome Plated
16	163141	Door Arm Latch Pin, Chrome Plated
17	18306	Retainer Clip, (2 Required)
18	023001	Door Arm Hinge Post Bolt (Upper) — Concentric Type —
19	023061	Door Arm Hinge Post Bolt (Lower) — Eccentric Type —
20	14643	Nut, For Lower Hinge Post Bolt
21	23181	Shim Washers

CLEVELAND RANGE CO., 1333 EAST 179th ST., CLEVELAND, OHIO 44110

Manufacturer reserves right of design improvement or modification, as warranted.

# MECHANICAL COMPARTMENT CONTROLS MODEL J PRESSURE STEAMERS—JAN. 1982 THRU PRESENT

LTHO IN USA. 0982

CLEVELAND RANGE CO., 1333 EAST 179th ST., CLEVELAND, OHIO 44110  
 Manufacturer reserves right of design improvement or modification, as warranted.

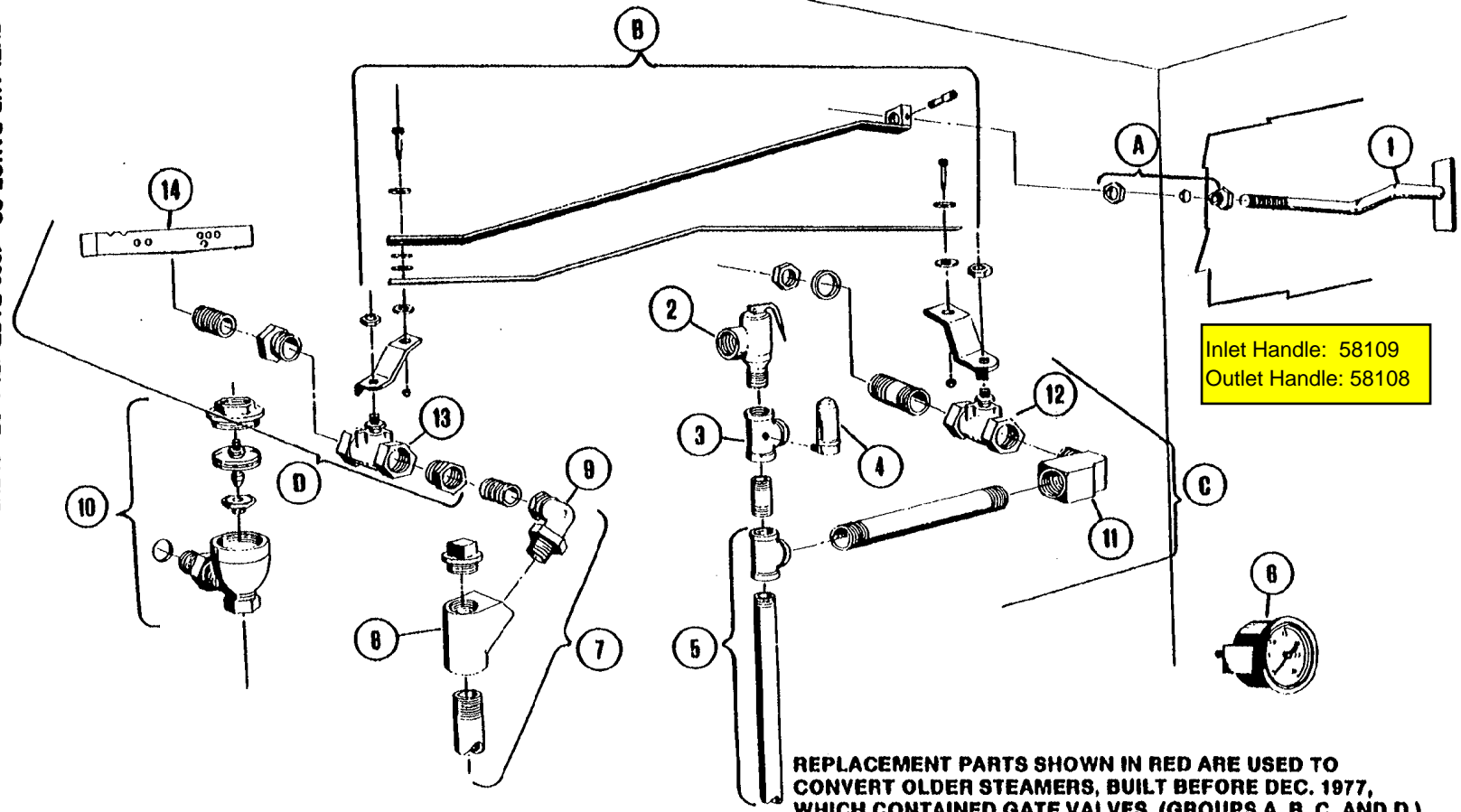

CLEVELAND RANGE CO., 1333 EAST 179th ST., CLEVELAND, OHIO 44110

Manufacturer reserves right of design improvement or modification, as warranted.

## MECHANICAL COMPARTMENT CONTROLS MODEL J PRESSURE STEAMERS—JAN. 1982 THRU PRESENT

REFERENCE NUMBER	PART NUMBER	DESCRIPTION
1	40850	Pull Rod Handle
2	22130	Valve, Safety, 8 PSI
3	70411	Tea, Special 3/4"
4	22140	Air Vent
5	42278	Inlet Manifold Ass'y.—2-Compt.—Mech. "J", Less Valves
	42277	Inlet Manifold Ass'y.—3-Compt.—Mech. "J", Less Valves
6	07173	Gauge, Pressure, Rear Mount, 0-30 PSI
7	42288	Exhaust Manifold Ass'y.—2-Compt., Model "J", Less Valves
	42289	Exhaust Manifold Ass'y.—3-Compt., Model "J", Less Valves
	02146	"Y" Bend
9	05263	Ell, 3/4" Radiator Union
10	20551	Thermostatic Trap—Plain End
11	05252	Ell, 1/2" Street
12	22212	Valve, 1/2" Ball, Inlet Steam
13	22213	Valve, 1" Butterfly, Exhaust Steam
14	41100	Drain Cover Screen
A	43765	Bushing Ass'y.
B	40879	Linkage Ass'y., Model "J"
C	42697	Conversion Kit, Inlet Valve—"J" Mech., Includes: 1/2" Inlet Steam Valve, 1/2" Street Elbow, 1/2" x 6" Nipple, 1/2" x 2 1/4" Special Nipple, (2) Locknuts, (2) Sealing Washers
D	40710	Conversion Kit, Exhaust Valve, Includes: 1" Exhaust Steam Valve, (2) 1" x 3/4" Bushings, 3/4" Close Nipple, Drain Cover Screen.

**NOTE: FOR SAFETY PURPOSES, DRAIN SCREEN COVER MUST BE IN PLACE WHEN OPERATING EQUIPMENT.**

**AUTOMATIC COMPARTMENT CONTROLS  
MODEL J PRESSURE STEAMERS—  
DEC. 1977 THRU PRESENT**

LTHO IN USA 1082

CLEVELAND RANGE CO., 1333 EAST 179th ST., CLEVELAND, OHIO 44110  
Manufacturer reserves right of design improvement or modification, as warranted.

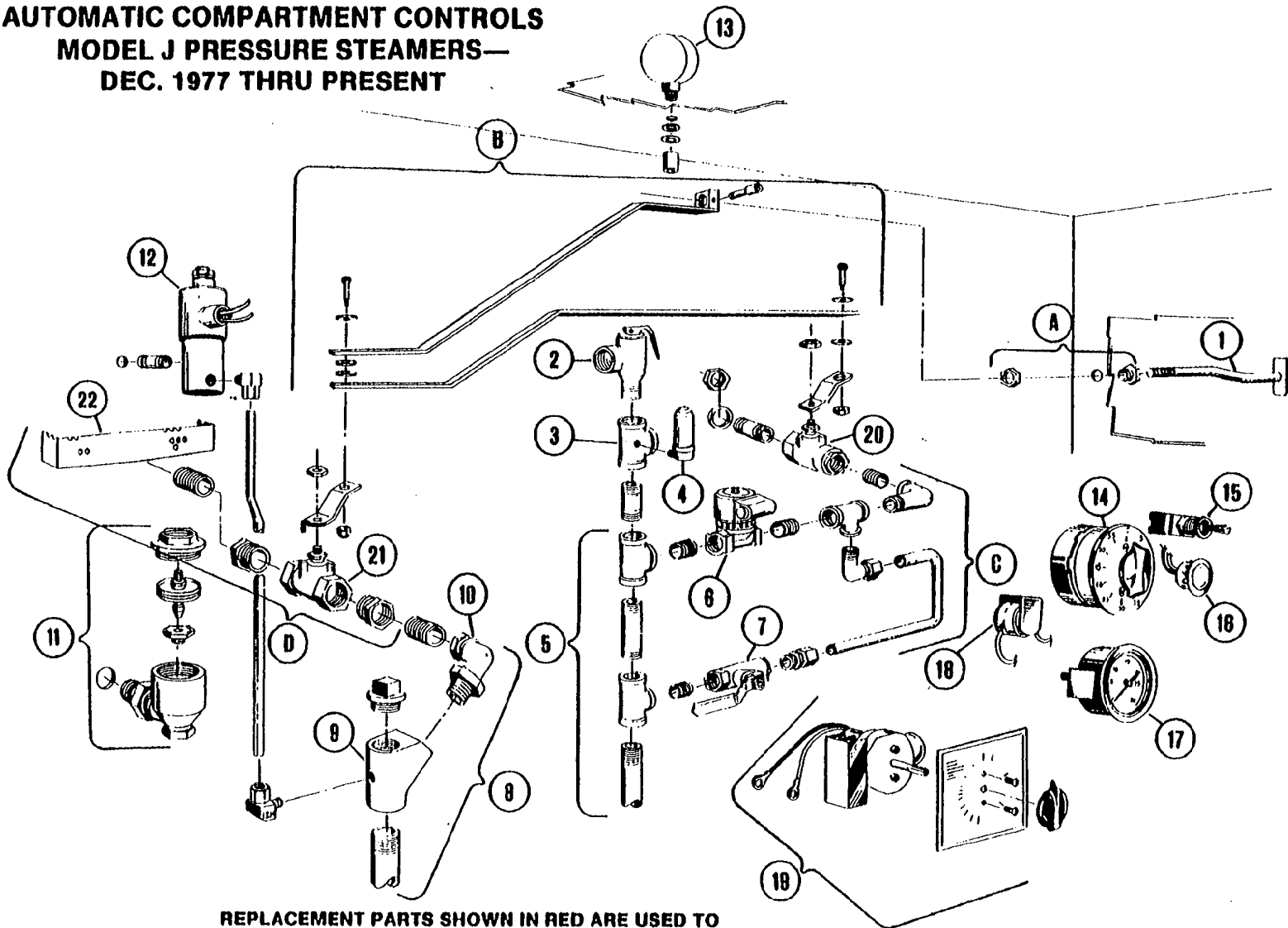

**REPLACEMENT PARTS SHOWN IN RED ARE USED TO  
CONVERT OLDER STEAMERS, BUILT BEFORE DEC. 1977,  
WHICH CONTAINED GATE VALVES. (GROUPS A, B, C, D.)**

CLEVELAND RANGE CO., 1333 EAST 179th ST., CLEVELAND, OHIO 44110  
 Manufacturer reserves right of design improvement or modification, as warranted.

## AUTOMATIC COMPARTMENT CONTROLS MODEL J PRESSURE STEAMERS—DEC. 1977 THRU PRESENT

REFERENCE NUMBER	PART NUMBER	DESCRIPTION
1	40850	Pull Rod Handle
2	22130	Valve, Safety, 8 PSI
3	70411	Tee, Special ¾"
4	22140	Air Vent
5	42286	Inlet Manifold Ass'y.—2-Compt.—Auto "J", Less Valves
	42297	Inlet Manifold Ass'y.—3-Compt.—Auto "J", Less Valves
6	22115	Valve, ½" Steam Inlet Solenoid
7	03278	Valve, Steam By-Pass
8	42288	Exhaust Manifold Ass'y.—2-Compt., Model "J", Less Valves
	42289	Exhaust Manifold Ass'y.—3-Compt., Model "J", Less Valves
9	43764	"Y" Bend—with ¼" Tapped Hole
10	05263	Elb, ¾" Radiator Union
11	20551	Thermostatic Trap—Plain End
12	22199	¼" Solenoid Valve, Auto Exhaust, 115 Volt, For Use With 40518 Timer
	22185	¼" Solenoid Valve, Auto Exhaust, 115 Volt, For Use With 40540 Timer
13	07172	Gauge, Pressure, Bottom Mount, 0-30 PSI
14	40518	Timer, 60 Min. Mechanical (Mfg. #70000)
15	19977	Switch—SPST
16	12161	Light, Signal
17	07173	Gauge, Pressure, Rear Mount, 0-30 PSI
18	41350	Buzzer
19	40540	Timer, 105 Min. (Mfg. 601)
20	22212	Valve, ½" Ball, Inlet Steam
21	22213	Valve, 1" Butterfly, Exhaust Steam
22	41100	Drain Cover Screen
A	43765	Bushing Ass'y.,
B	40879	Linkage Ass'y., Model "J"
C	40712	Conversion Kit, Inlet Valve—"J" Auto, Includes: ½" Inlet Steam Valve, ½" Street Elbow, ¾" Tube Fing., ¾" — 90° Tube Fing., (2) ½" Close Nipples, ½" x 2¼" Special Nipple, ½" x ½" x ¾" Tee, ¾" x 12" Tube, (2) Locknuts, (2) Sealing Washers
D	40710	Conversion Kit, Exhaust Valve, Includes: 1" Exhaust Steam Valve, (2) 1" x ¾" Bushings, ¾" Close Nipple, Drain Cover Screen.

**NOTE: FOR SAFETY PURPOSES, DRAIN SCREEN COVER MUST BE IN PLACE WHEN OPERATING EQUIPMENT**

## MODELS J AND K PRESSURE STEAMER SLIDE SETS

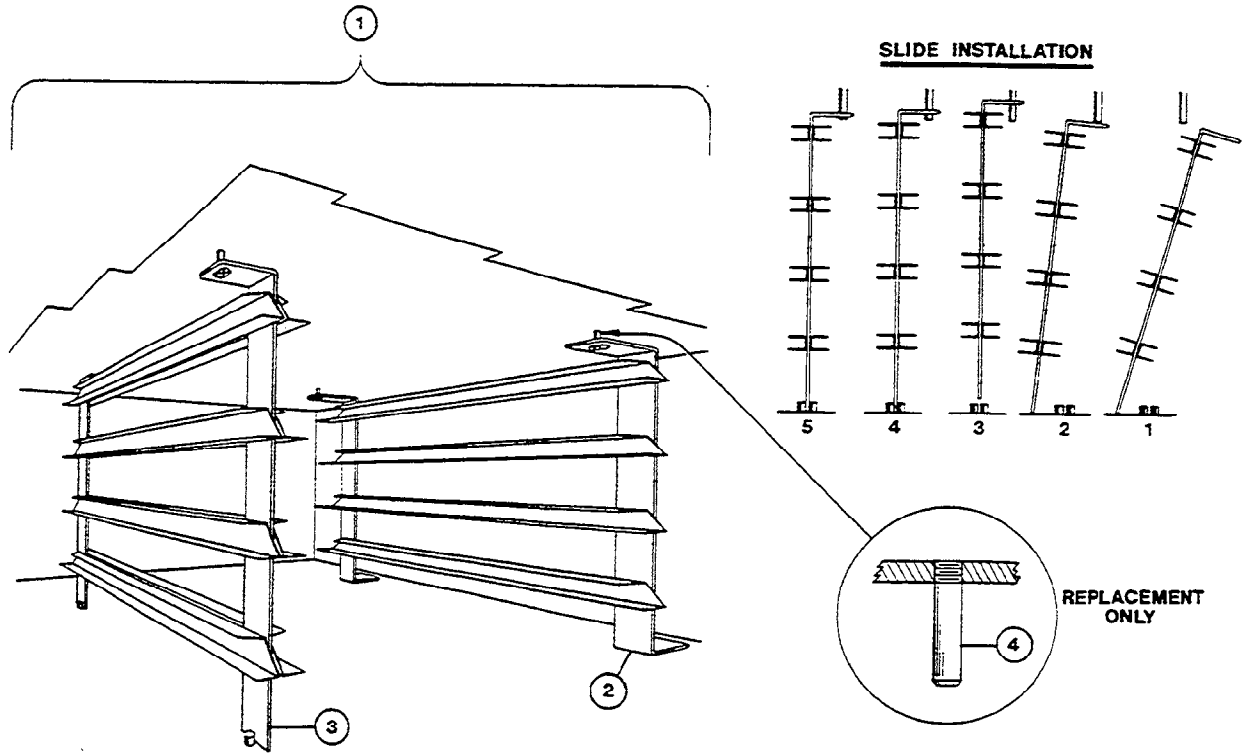

REFERENCE NUMBER	PART NUMBER	DESCRIPTION
1	41440	Pan Support Slide Set, Model J Complete
	41442	Pan Support Slide Set, Model K Complete
2	41430	Right or Left Side Slide Rack, 2 Per Compt Req'd, Model J
	41432	Right or Left Side Slide Rack, 2 Per Compt Req'd, Model K
3	41435	Center Slide Rack Model J, 1 Req'd Per Compt
	41437	Center Slide Rack Model K, 1 Req'd Per Compt
4	19909	Replacement Top Studs (Screw-In) J or K (Set of 6)

CLEVELAND RANGE, INC., 1333 EAST 179th ST., CLEVELAND, OHIO 44110

Manufacturer reserves right of design improvement or modification, as warranted.



LET.	REVISIONS	DATE	BY
A	ADDED P/N 108898, P/N 23110 WAS	05-23-94	EAG
-	QTY(18), P/N 108899 WAS 14685		
-	PER E.O. #C-2843		

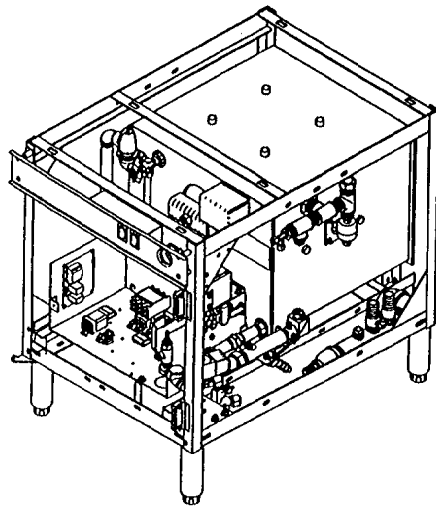

ASSEMBLED VIEW

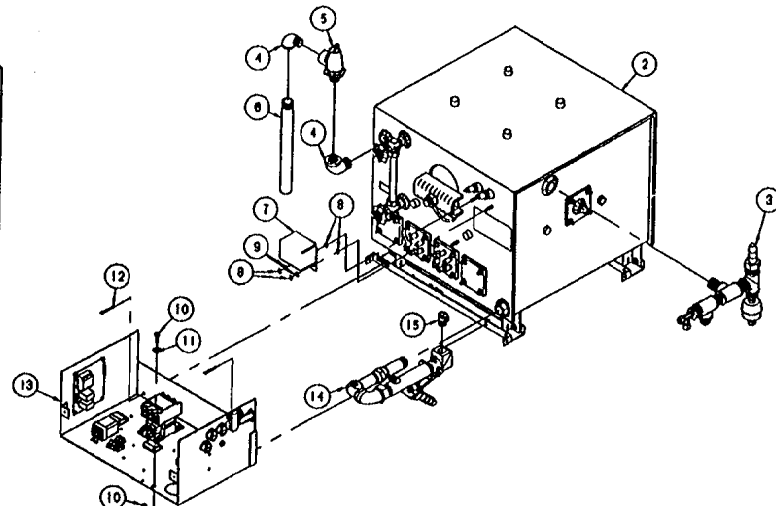

SEE DETAIL 'A'

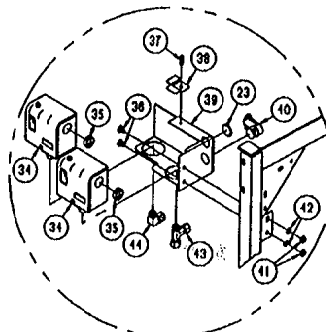
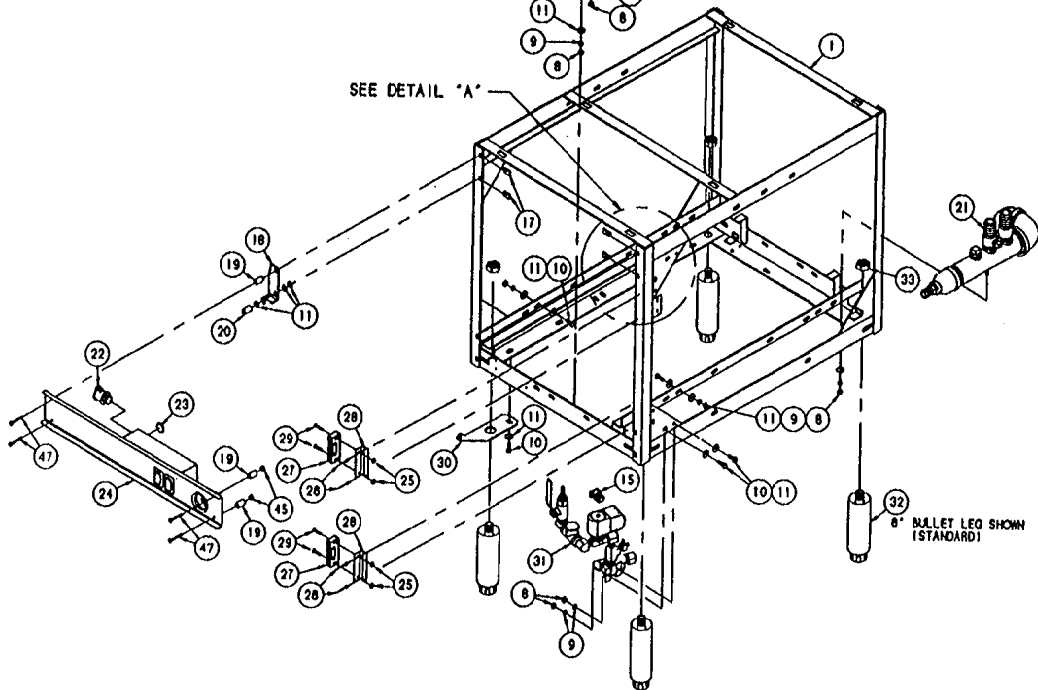

DETAIL A

THIS DESIGN DESCRIBES A PROPRIETARY ITEM AND IS THE PROPERTY OF CLEVELAND RANGE. THIS DRAWING IS NOT TO BE COPIED OR USED WITHOUT THE APPROVAL OF CLEVELAND RANGE.

NEXT ASS'Y: DFD0014

ITEM	QTY.	PART NO.	DESCRIPTION
47	4	108898	SCREW, TRUSS HD, P.H.P.S., 10-24 X 1-1/2
48	A/R	00934	SEALANT, RECTORSAL
45	2	19552	SPACER, .158 LONG
44	1	08196	FITTING, COMP, 3/8 X 1/4 IPT, 90°
43	1	100893	FITTING, COMP TEE 3/8 X 1/4 IPT X 3/4
42	2	23137	WASHER, LOCK INT. TOOTH, 1/4 5/8
41	2	14888	NUT, HEX JAM, 1/4-20, 5/8
40	1	105247	CONNECTOR, 1/2 X 90° SNAP-TITE
39	1	529241	BRACKET, PRESSURE SWITCH, GAS/ELECT
38	1	52499	BRACKET, PRESSURE SWITCH RETAINER
37	1	19146	SCREW, HEX WASHER HEAD, #10 X .5
36	2	19218	SCREW, HEX HEAD, 1/4-20 X .375 5/8
35	2	02599	BUSHING, INSULATING 3/8 X 1/2 HEYCO
34	2	19947	SWITCH, PRESSURE CONTROL
33	4	14888	NUT, HEX JAM 3/4-10 ZINC PLTD
32	4	08158	LEG, BULLET 8"
31	1	44070	WATER FEED ASSY, REV BEND GEN
30	1	1026892	HINGE, LOWER LEFT HINGE
29	4	19206	SCREW, RD. HEAD 8-32 X 1 ZINC PLTD
28	2	53274	CLIP, MAGNET CATCH 5/8
27	2	03100	CATCH, MAGNETIC
26	A/R	18358	RIVET, 1/8 DIA. FLUSH BREAK 5/8
25	4	14874	NUT, HEX 8-32 ZINC PLATED
24	1	1048073	CONSOLE ASSY, ROOM 2 SWITCH
23	2	19329	PLUG, SNAP-IN 1/2" FOR 1/8" HOLE
22	1	105218	CONNECTOR, GREENFIELD 1/2 STRAIGHT
21	1	42749	DRAIN ASSEMBLY
20	1	195512	SPACER
19	3	19553	SPACER
18	1	412182	BRACKET, ASS'Y, TOP HINGE, L.S.
17	4	108899	NUT, SLIP ON, 10-24, TINNEMAN
16	1	52529	BRACKET, MOUNTING, ELECTRIC BOX
15	2	105249	CONNECTOR, GREENFIELD 3/8 STRAIGHT
14	1	40889	BLOWDOWN ASSY, 24CEM, ELECTRIC 'J'
13	1	NFX001	ELECTRIC BOX ASSEMBLY
12	2	19292	SCREW, ROUND HEAD, SLTD 1/4-20 X 1"
11	12	23110	WASHER, FLAT 1/4 X 5/8 X .085
10	7	19280	SCREW, HEX HEAD, 1/4-20 X 3/4
9	9	23105	WASHER, LOCK 1/4 KATLINK STYLE
8	11	14818	NUT, HEX 1/4-20 5/8
7	1	52305	BOX, PROBE COVER, 2 PROBES, A.C.S.
6	1	14487	HIPPLE, T.O.E., 3/4" X 8", BLACK
5	1	22131	VALVE, SAFETY, 3/4" IS PBI, BRONZE
4	2	03259	ELBOW, STREET, 3/4", 90° BLACK
3	1	428124	STEAM OUTLET ASSEMBLY
-	-	408201W1	ELECT GENERATOR W/REF PARTS 4 HEATA
2	-	408201W3	ELECT GENERATOR W/REF PARTS 3 HEATA
-	-	408201W2	ELECT GENERATOR W/REF PARTS 2 HEATA
-	-	411121	BASE, WELDMENT, ROOM, A.C.S.
1	-	41112	BASE WELDMENT, ROOM, 3/3

ITEM	QTY.	PART NO.	DESCRIPTION
TOLERANCES (UNLESS AS NOTED)			
<b>CLEVELAND RANGE INC.</b>			
1339 East 179th St., Cleveland, Ohio 44110-3574			
DECIMAL	SCALE	DRAWN BY	APPROVED BY
± N/A	1/16"=1	E. GRIEYAS	M.T.
ANGULAR	TITLE	BASE ASSEMBLY, ELECTRIC GENERATOR	
± N/A		ROOM, 24XW/38XW/48XW	
CK	DATE	DRAWING NO.	REV.
	10-08-93	C - DFD0001	A

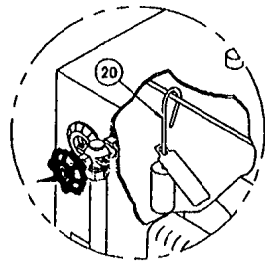
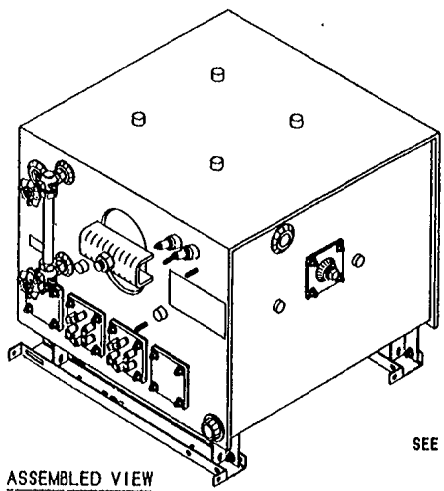

- NOTES:
1. CHANNEL SUPPORT SHOWN (P/N 89966) IS USED ON 800MM BASE. CHANNEL SUPPORT NOT SHOWN (P/N 89967) IS USED ON 900 & 1050MM BASES.
  2. 9KW HEATER IS RED LOBSTER UNITS ONLY.

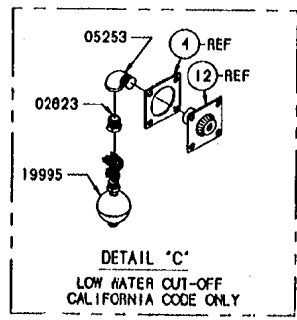
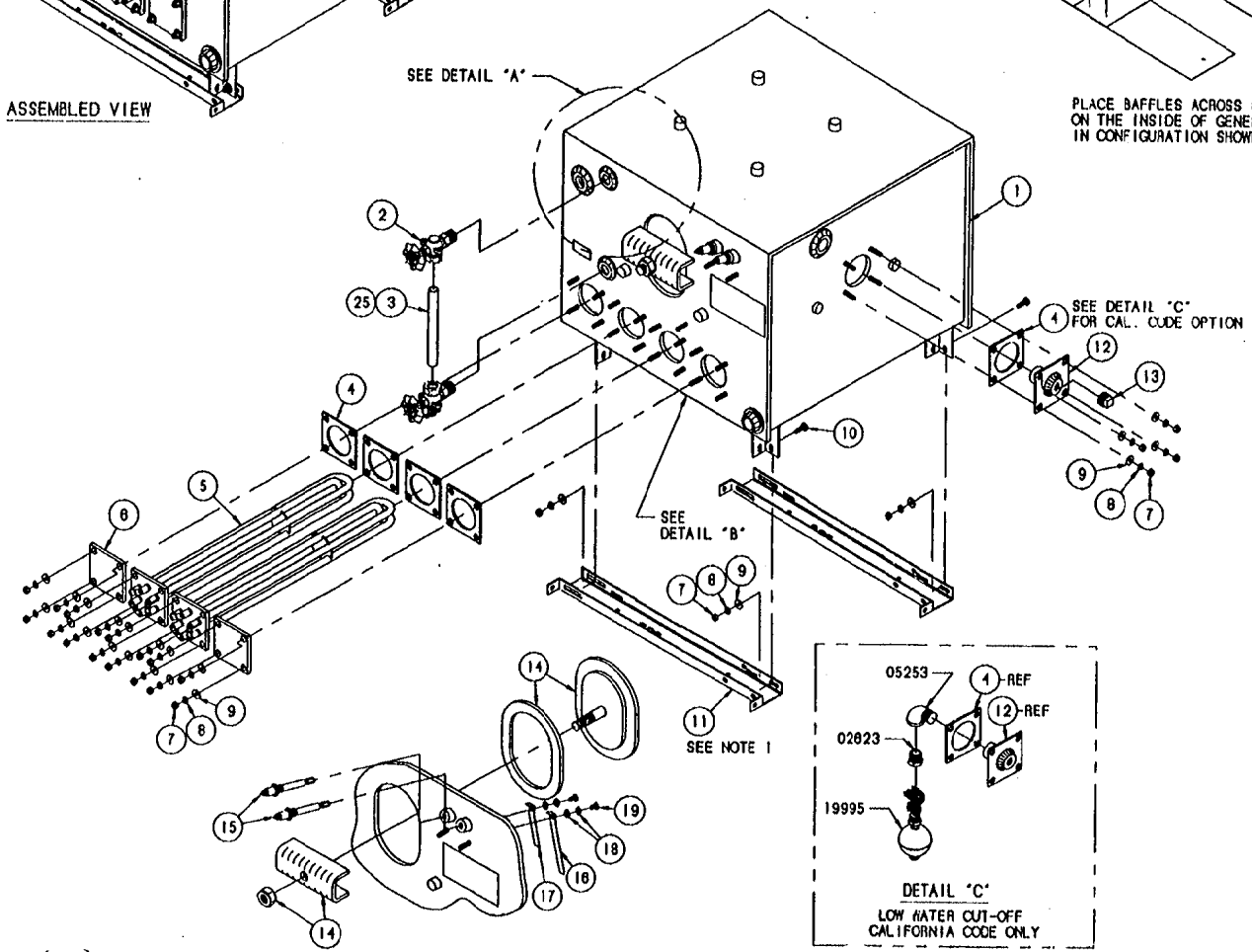
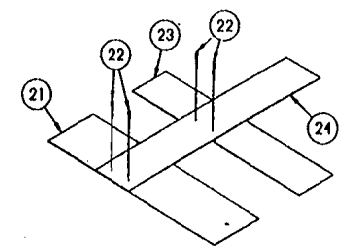

ITEM	QTY	PART NO.	DESCRIPTION
25	A/R	00934	SEALANT, RECTORSEAL
24	1	52165	BAFFLE, KEEPER, ELECTRIC BOILER
23	1	102384	BAFFLE, CENTER, ELECTRIC STEAM GEN
22	4	18328	PIN, COTTER, 1/16 X 1, BRASS
21	1	52165	BAFFLE, FRONT, ELECTRIC BOILER
20	1	43895	ANODE ASSM CORROSION PREVENTATIVE
19	2	19218	SCREW, HEX HEAD, 1/4-20 X 3/8 S/S
18	4	23151	WASHER, INTERNAL TOOTH LOCK, 1/4
17	1	82452	EXTENSION, WATER PROBE 1/2 X 3-1/8
16	1	82453	EXTENSION, WATER PROBE 1/2 X 4-5/8
15	2	18871	PROBE WARRICK, 4-5/16" LG
14	1	40421	HAND HOLD PLATE & BAR ASSEMBLY
13	1	18802	PLUG, SQUARE 1/2 PIPE, BLACK
12	1	41943	PLATE, MOUNTING
11	-	89966	SUPPORT, GEN MTG CHANNEL 800MM S/S
11	-	89967	SUPPORT, GEN MTG CHANNEL 900/1050MM
10	4	19288	SCREW, HEX HEAD, 1/4-20 X 3/4
9	24	23110	WASHER, FLAT, 1/4 S/S
8	24	23105	WASHER, LOCK MED. PAT., 1/4" S/S
7	24	14618	NUT, HEX, 1/4-20, S/S
6	2	16546	PLATE, BLOCK-OFF
2	2	08244	HEATER, 9 KW, 600 V, 1 PHASE
2	2	08243	HEATER, 9 KW, 440/480 V, 1 PHASE
2	2	08242	HEATER, 9 KW, 220/240 V, 1 PHASE
2	2	08241	HEATER, 9 KW, 208 V, 1 PHASE
2	2	08237	HEATER, 9 KW, 440/480 V, 3 PHASE
2	2	08236	HEATER, 9 KW, 220/240 V, 3 PHASE
2	2	08235	HEATER, 9 KW, 208 V, 3 PHASE
2	2	08234	HEATER, 9 KW, 600 V, 3 PHASE
2	2	08210	HEATER, 12 KW, 440/480 V, 1 PHASE
2	2	08215	HEATER, 12 KW, 230/240 V, 1 PHASE
2	2	08214	HEATER, 12 KW, 208/220 V, 1 PHASE
2	2	08197	HEATER, 12 KW, 220/380 V, 3 PHASE
2	2	08187	HEATER, 12 KW, 140, 480 V, 3 PHASE
2	2	08186	HEATER, 12 KW, 230/240 V, 3 PHASE
2	2	08185	HEATER, 12 KW, 208 V, 3 PHASE
2	2	08184	HEATER, 12 KW, 575 V, 3 PHASE
2	2	08183	HEATER, 12 KW, 600 V, 3 PHASE
2	2	08157	HEATER, 9 KW, 240/360 V, 3 PHASE
2	2	08156	HEATER, 9 KW, 240/415 V, 3 PHASE
2	2	08155	HEATER, 12 KW, 240/415 V, 3 PHASE
4	5	07128	GASKET, HEATER
3	1	07302	GAUGE, WATER, 5/8 X 8, GLASS
2	1	07176	GAUGE, FITTINGS, WATER, 1/2"
1	1	408201	GENERATOR, ASSY 2 PROBE ELECT

THIS DESIGN IS A PROPRIETARY ITEM OF CLEVELAND RANGE AND IS THE PROPERTY OF CLEVELAND RANGE. THIS DRAWING IS TO BE COPIED OR USED WITHOUT THE APPROVAL OF CLEVELAND RANGE.

DETAIL "B"

HT ASS'Y: DFD0001  
DFE0002  
DFP0003

TOLERANCES (EXCEPT AS NOTED)

SCALE: 3/16"=1"

DATE: 10-08-93

DRAWING NO.: C - 408201W2

REV: -

CLEVELAND RANGE INC.  
1533 East 179th St., Cleveland, Ohio 44110-2571

DRAWN BY: E. GRIVIN

APPROVED BY:

TITLE: ELECTRIC GENERATOR PROBE

SEMBLY

NOTES:

- CHANNEL SUPPORT SHOWN (P/N 89988) IS USED ON 600MM BASE. CHANNEL SUPPORT NOT SHOWN (P/N 89987) IS USED ON 900 & 1030MM BASES.

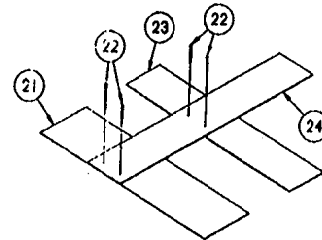

PLACE BAFFLES ACROSS RODS ON THE INSIDE OF GENERATOR IN CONFIGURATION SHOWN

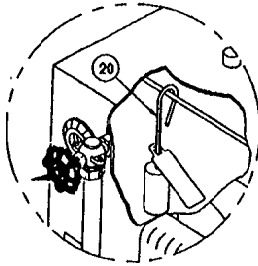

DETAIL "A"  
INSTALL ITEM 20 AS SHOWN  
INSIDE GENERATOR

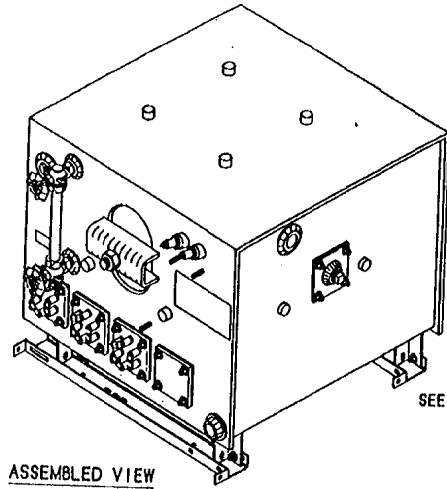

ASSEMBLED VIEW

SEE DETAIL "A"

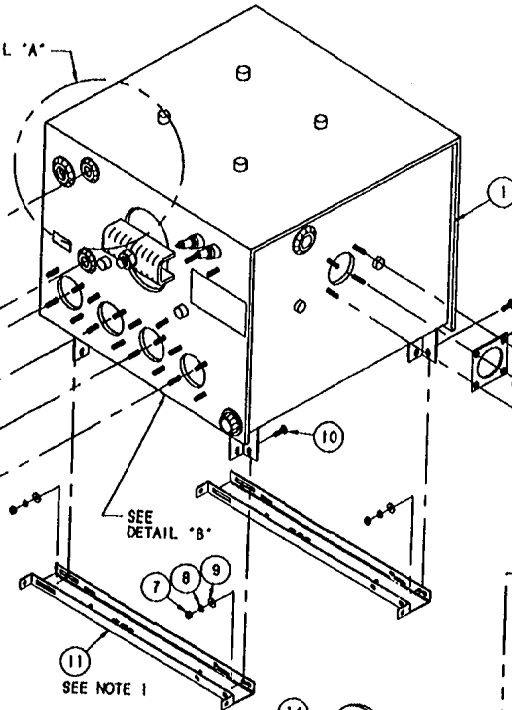

SEE DETAIL "B"

SEE NOTE 1

SEE DETAIL "C"  
FOR CAL. CODE OPTION

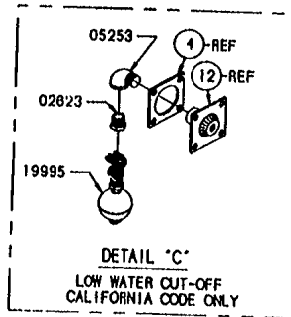

DETAIL "C"  
LOW WATER CUT-OFF  
CALIFORNIA CODE ONLY

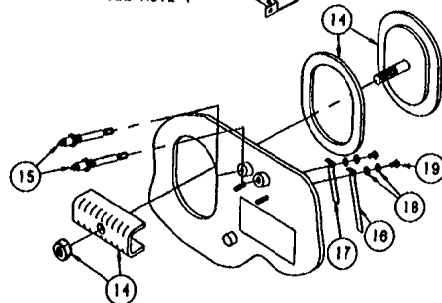

DETAIL "B"

ITEM	QTY	PART NO.	DESCRIPTION
25	1	00934	SEALANT, RECTORSEAL
24	1	52185	BAFFLE, KEEPER, ELECTRIC BOILER
23	1	102384	BAFFLE, CENTER, ELECTRIC STEAM GEN
22	4	18328	PIN, COTTER, 1/16 X 1, BRASS
21	1	52185	BAFFLE, FRONT, ELECTRIC BOILER
20	1	43895	ANODE ASSM CORROSION PREVENTATIVE
19	2	19218	SCREW, HEX HEAD, 1/4-20 X 3/8 S/S
18	4	23151	WASHER, INTERNAL TOOTH LOCK, 1/4
17	1	82452	EXTENSION, WATER PROBE 1/2 X 3-1/8
16	1	82453	EXTENSION, WATER PROBE 1/2 X 4-5/8
15	2	16871	PROBE WARRICK, 4-5/16" LG
14	1	40421	HAND HOLD PLATE & BAR ASSEMBLY
13	1	16802	PLUG, SQUARE 1/2 PIPE, BLACK
12	1	41943	PLATE, MOUNTING
11	-	89988	SUPPORT, GEN MTG CHANNEL 600MM S/S
10	-	89987	SUPPORT, GEN MTG CHANNEL 900/1030MM
9	4	19288	SCREW, HEX HEAD, 1/4-20 X 3/4
8	24	23116	WASHER, FLAT, 1/4 S/S
7	24	23105	WASHER, LOCK MED. PAT., 1/4" S/S
6	24	14818	NUT, HEX, 1/4-20, S/S
5	1	18546	PLATE, BLOCK-OFF
3	3	08197	HEATER, 12 KW, 220/380 V, 3 PHASE
3	3	08167	HEATER, 12 KW, 440,480 V, 3 PHASE
3	3	08188	HEATER, 12 KW, 230/240 V, 3 PHASE
3	3	08185	HEATER, 12 KW, 208 V, 3 PHASE
3	3	08183	HEATER, 12 KW, 600 V, 3 PHASE
3	3	08155	HEATER, 12 KW, 240/415 V, 3 PHASE
4	5	07128	GASKET, HEATER
3	1	07302	GAUGE, WATER, 5/8 X 1 1/8, GLASS
2	1	07176	GAUGE, FITTINGS, WATER, 1/2"
1	1	40820	GENERATOR, ASSY 2 PROBE ELECT

THIS DESIGN DESCRIBES A PROPRIETARY ITEM AND IS THE PROPERTY OF CLEVELAND RANGE. THIS DRAWING IS NOT TO BE COPIED OR USED WITHOUT THE APPROVAL OF CLEVELAND RANGE.

NEXT ASS'Y: DFD0001  
DFE0002  
DFF0003

TOLERANCES (UNLESS AS NOTED)		CLEVELAND RANGE INC. 1323 East 178th St. Cleveland, Ohio 44110-2374	
DECIMAL ± N/A	ANGLE 3/16±	DRAWN BY E. GRIVEAS	APPROVED BY
AREALAN ± N/A	TITLE ELECTRIC GENERATOR ASSEMBLY 2 PROBE, 3 HEATER	DATE 10-08-93	REV. C - 408201WR

NOTES:

- CHANNEL SUPPORT SHOWN (P/N 69986) IS USED ON 600MM BASE. CHANNEL SUPPORT NOT SHOWN (P/N 69987) IS USED ON 900 & 1050MM BASES.

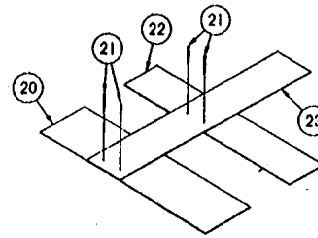

PLACE BAFFLES ACROSS RODS ON THE INSIDE OF GENERATOR IN CONFIGURATION SHOWN

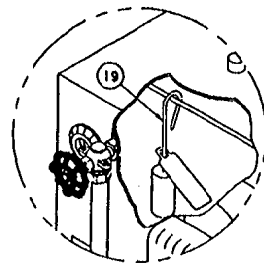

DETAIL 'A'  
INSTALL ITEM 20 AS SHOWN INSIDE GENERATOR

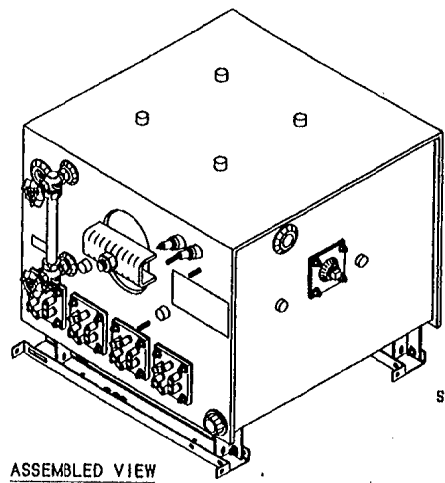

ASSEMBLED VIEW

SEE DETAIL 'A'

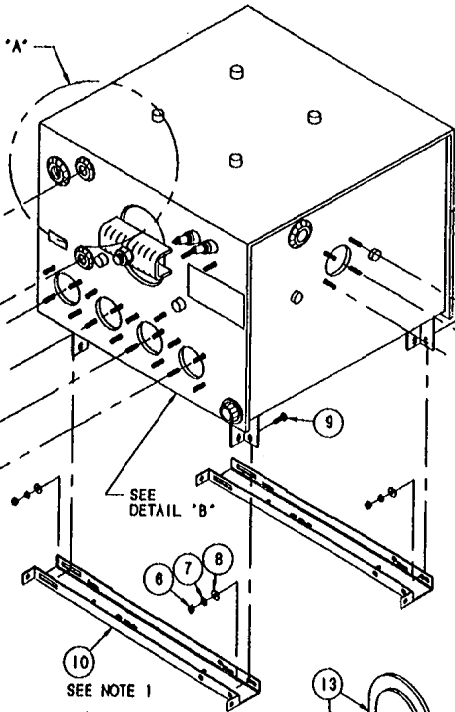

SEE DETAIL 'B'

SEE NOTE 1

SEE DETAIL 'C' FOR CAL. CODE OPTION

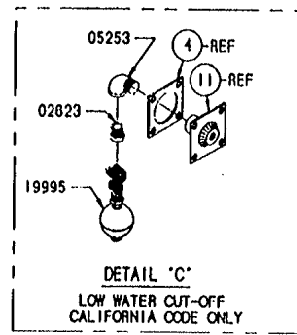

DETAIL 'C'  
LOW WATER CUT-OFF CALIFORNIA CODE ONLY

ITEM	QTY	PART NO.	DESCRIPTION
24	1	00934	SEALANT, RECTORSEAL
23	1	52165	BAFFLE, KEEPER, ELECTRIC BOILER
22	1	102384	BAFFLE, CENTER, ELECTRIC STEAM GEN
21	4	16328	PIN, COTTER, 1/16 X 1, BRASS
20	1	52165	BAFFLE, FRONT, ELECTRIC BOILER
19	1	43895	ANODE ASSM CORROSION PREVENTATIVE
18	2	19218	SCREW, HEX HEAD, 1/4-20 X 3/8 S/S
17	4	29151	WASHER, INTERNAL TOOTH LOCK, 1/4
16	1	02452	EXTENSION, WATER PROBE 1/2 X 3-1/8
15	1	02453	EXTENSION, WATER PROBE 1/2 X 4-5/8
14	2	16871	PROBE WARRICK, 4-5/16" LG
13	1	40421	HAND HOLD PLATE & BAR ASSEMBLY
12	1	16802	PLUG, SQUARE 1/2 PIPE, BLACK
11	1	41943	PLATE, MOUNTING
		69988	SUPPORT, GEN MTG CHANNEL 600MM S/S
10		69987	SUPPORT, GEN MTG CHANNEL 900/1050MM
9	4	19288	SCREW, HEX HEAD, 1/4-20 X 3/4
8	24	23116	WASHER, FLAT, 1/4 S/S
7	24	23105	WASHER, LOCK MED. PAT., 1/4" S/S
6	24	14818	NUT, HEX, 1/4-20, S/S
		08197	HEATER, 12 KW, 220/380 V, 3 PHASE
		08107	HEATER, 12 KW, 440/480 V, 3 PHASE
		08168	HEATER, 12 KW, 230/240 V, 3 PHASE
		08185	HEATER, 12 KW, 208 V, 3 PHASE
		08184	HEATER, 12 KW, 575 V, 3 PHASE
		08183	HEATER, 12 KW, 600 V, 3 PHASE
		08155	HEATER, 12 KW, 240/415 V, 3 PHASE
4	5	07128	GASKET, HEATER
3	1	07302	GAUGE, WATER, 5/8 X 6, GLASS
2	1	07178	GAUGE, FITTINGS, WATER, 1/2"
1	1	408201	GENERATOR, ASSY 2 PROBE ELECT

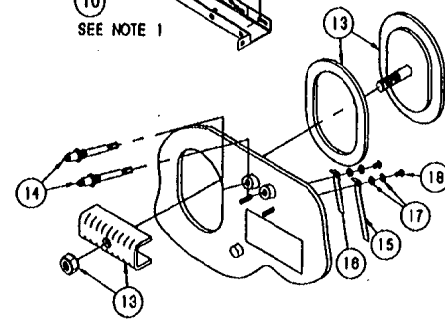

DETAIL 'B'

THIS DESIGN IS A PROPRIETARY ITEM AND IS THE PROPERTY OF CLEVELAND RANGE. THIS DRAWING IS NOT TO BE COPIED OR USED WITHOUT THE APPROVAL OF CLEVELAND RANGE.

NEXT ASS'Y: DFD0001  
DFE0002  
DFP0003

TOLERANCES (EXCEPT AS NOTED)			
<b>CLEVELAND RANGE INC.</b> 1333 East 179th St. Cleveland, Ohio 44110-2574			
DECIMAL	BOLE	DRAWN BY	APPROVED BY
± N/A	3/16±	E. GRIVEAS	
ARELLAN	TITLE	ELECTRIC GENERA	WPLY
± N/A		2 PROBE, 4 i	
DATE	DRAWING NO.		REV
10-06-93	C - 408201W4		

NOTE:

1. THIS DRAWING REFLECTS MOST COMMON CONFIGURATION OF ELECTRICAL BOX (24KW208V).
2. REFER TO DWG. NFX0002 FOR ELECTRIC BOX W/INTERMITTENT BLOWDOWN.

LET.	REVISIONS	DATE	BY
------	-----------	------	----

Cover 53577

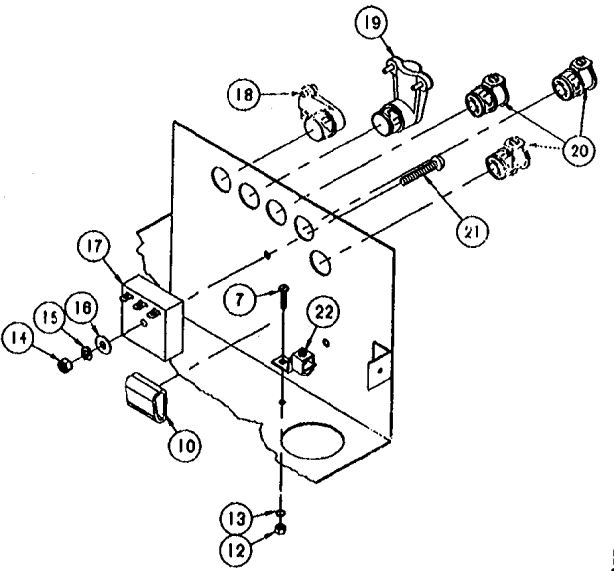
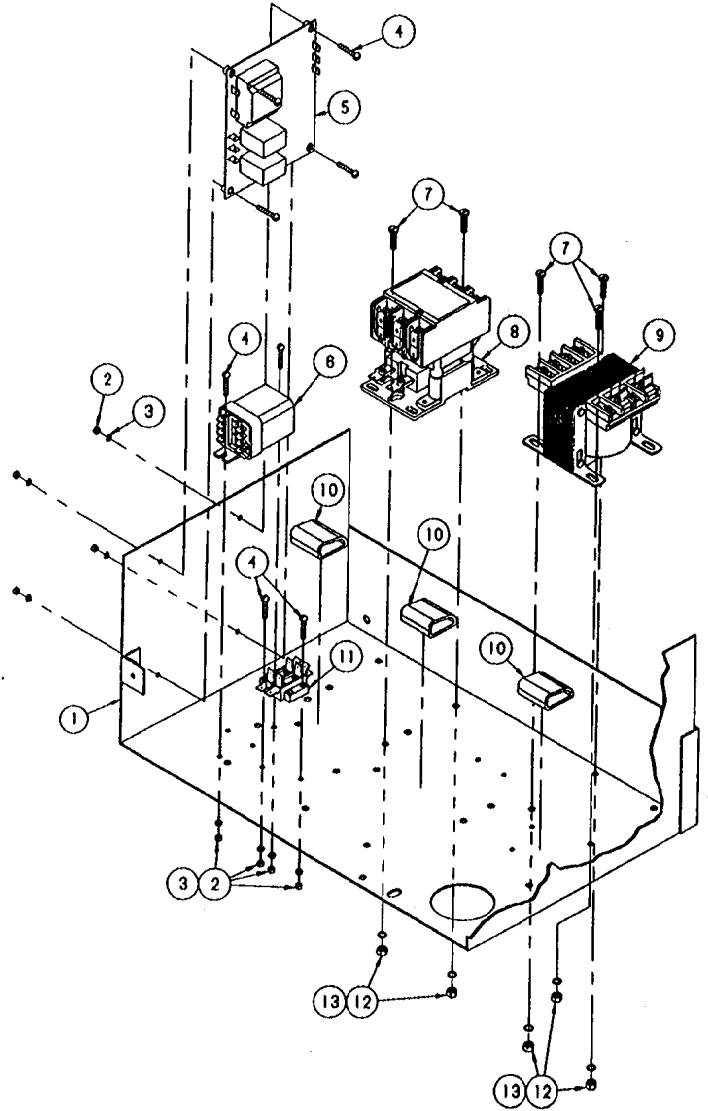
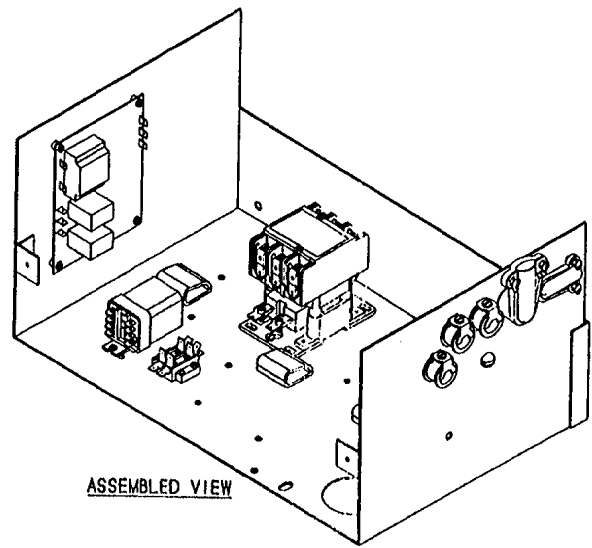

ITEM	QTY.	PART NO.	DESCRIPTION
22	1	12331	LUG, GROUND, SOLDERLESS, FOR 2-GA. WIRE
21	1	19285	SCREW, ROUND HEAD, 1/4-20 X 1-1/2, S/S
20	3	105243	CONNECTOR, GREENFIELD 3/8" STRAIGHT
19	1	105247	CONNECTOR, GREENFIELD 1/2 X 90°SNAPTITE
18	1	105245	CONNECTOR, GREENFIELD 3/8 X 90°SNAPTITE
17	1	20478	TIMER, SOLID STATE INTERVAL 3 MINUTE
16	1	23116	WASHER, FLAT, 1/4" ID X .085 THK
15	1	23137	WASHER, LOCK, INT. TOOTH, 1/4", S/S
14	1	14818	NUT, HEX, 1/4-20, S/S, FULL FINISHED
13	8	23114	WASHER, LOCK INT. TOOTH #10 TYPE A OR B
12	8	14854	NUT, HEX #10-24 STEEL
11	1	44188	TERMINAL BLOCK ASM. 2 POLE
10	4	23432	CLIP, MOUNTING, WIRE/CABLE, 1.25 X 1.50
9	1	20535	TRANSFORMER, 150VA
8	1	03508	CONTACTOR, 3 POLE, 75 AMP, 208/204V
7	5	19287	SCREW, PAN HEAD, 10-24 X .50", S/S
6	1	108581	RELAY, 120V, ELECTRIC GENERATOR
5	1	23198	CONTROL, WATER LEVEL
4	8	19163	SCREW, ROUND HEAD SLTD, 8-32 X .75
3	8	23111	WASHER, LOCK, INT. TOOTH #6 ZINC PLTD
2	8	14874	NUT, HEX, 8-32, ZINC PLTD
1	1	40937	BOX, WELDMENT, ELECTRIC

TOLERANCES (EXCEPT AS NOTED)		CLEVELAND RANGE INC. 1333 East 179th St. Cleveland, Ohio 44110-2574	
DECIMAL	SCALE	DRAWN BY	APPROVED BY
± N/A	3/8=1	E. GRIVEAS	NLT
ANGULAR	TITLE	ELECTRIC BOX ASSEMBLY ELECTRIC GENERATOR	
± N/A	DATE	DRAWING NO.	REV.
CK	02-10-94	C - NFX0001	

THIS DESIGN DESCRIBES A PROPRIETARY ITEM AND IS THE PROPERTY OF CLEVELAND RANGE. THIS DRAWING IS NOT TO BE COPIED OR USED WITHOUT THE APPROVAL OF CLEVELAND RANGE.

NEXT ASSY: DFD0001  
DFE0002  
DIF0003

NOTE:

1. THIS DRAWING REFLECTS MOST COMMON CONFIGURATION OF ELECTRICAL BOX (24KW208V).

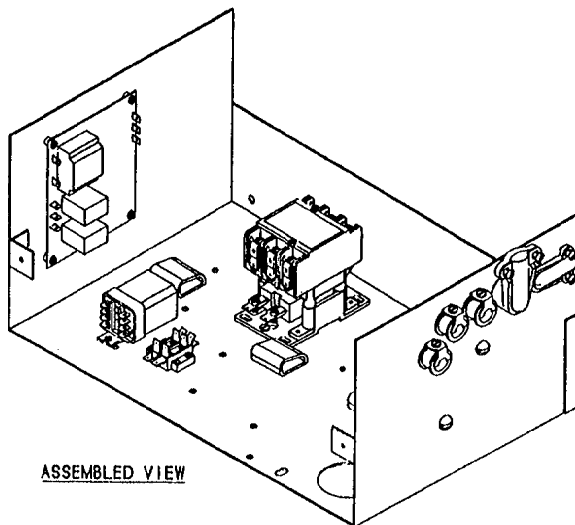

ASSEMBLED VIEW

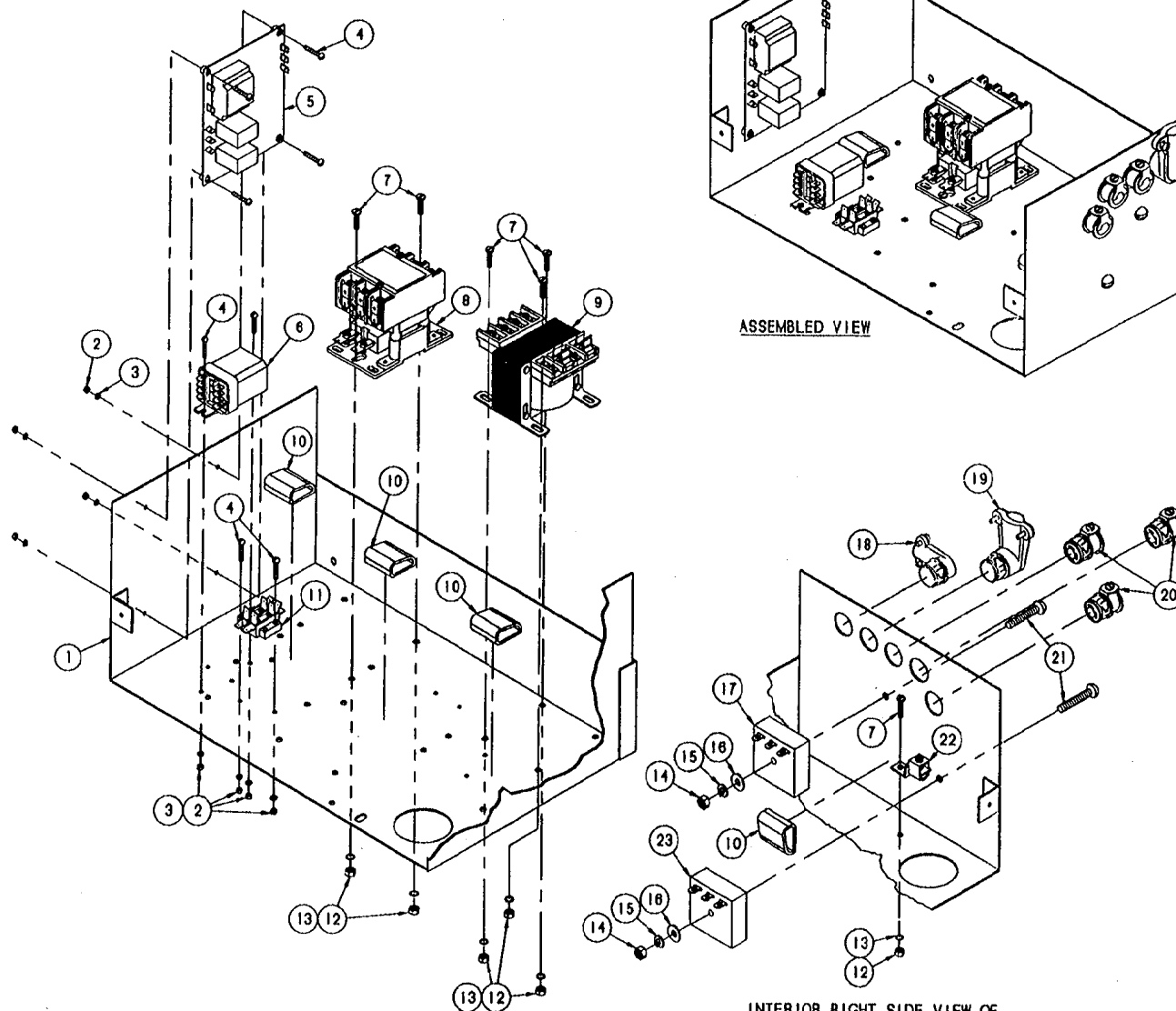

INTERIOR RIGHT SIDE VIEW OF ELECTRICAL BOX, ROTATED 90°

ITEM	QTY.	PART NO.	DESCRIPTION
23	1	104718	TIMER, RECYCLING, GENERATOR W/BLOWDOWN
22	1	12331	LUG, GROUND, SOLDERLESS, FOR 2-GA. WIRE
21	2	19285	SCREW, ROUND HEAD, 1/4-20 X 1-1/2, S/S
20	3	105249	CONNECTOR, GREENFIELD 3/8" STRAIGHT
19	1	105247	CONNECTOR, GREENFIELD 1/2 X 90°SNAPTITE
18	1	105245	CONNECTOR, GREENFIELD 3/8 X 90°SNAPTITE
17	1	20478	TIMER, SOLID STATE INTERVAL 3 MINUTE
16	2	23118	WASHER, FLAT, 1/4" ID X .065 THK
15	2	23137	WASHER, LOCK, INT. TOOTH, 1/4", S/S
14	2	14818	NUT, HEX, 1/4-20, S/S, FULL FINISHED
13	8	23114	WASHER, LOCK INT. TOOTH #10 TYPE A OR B
12	8	14854	NUT, HEX #10-24 STEEL
11	1	44168	TERMINAL BLOCK ASM. 2 POLE
10	4	23432	CLIP, MOUNTING, WIRE/CABLE, 1.25 X 1.50
9	1	20535	TRANSFORMER, 150VA
8	1	03508	CONTACTOR, 3 POLE, 75 AMP, 208/204V
7	5	19287	SCREW, PAN HEAD, 10-24 X .50", S/S
6	1	108581	RELAY, 120V, ELECTRIC GENERATOR
5	1	23198	CONTROL, WATER LEVEL
4	8	19183	SCREW, ROUND HEAD SLTD, 6-32 X .75
3	8	23111	WASHER, LOCK, INT. TOOTH #6 ZINC PLTD
2	8	14874	NUT, HEX, 6-32, ZINC PLTD
1	1	40937	BOX, WELDMENT, ELECTRIC

TOLERANCES (EXCEPT AS NOTED)		CLEVELAND RANGE INC. 1333 East 179th St. Cleveland, Ohio 44110-2574	
DECIMAL ± N/A	SCALE 3/8=1	DRAWN BY E. GRIVEAS	APPROVED BY NLT
ANGULAR ± N/A	TITLE ELECTRIC BOX ASSEMBLY W/INTERMITTENT BLOWDOWN, EL. GENERATOR		
CK	DATE 02-10-94	DRAWING NO. C - NFX0002	REV. -

THIS DESIGN / IS A PROPRIETARY ITEM AND IS THE P OF CLEVELAND RANGE. THIS DRAWING TO BE COPIED OR USED WITHOUT THE APPROVAL OF CLEVELAND RANGE.

OPTION FOR NEXT ASS'Y: DFD0001 DFE0002 DFF0003

NOTE: 1. MOUNT P/N 100064 TO LOWER RIGHT FRONT CUSSET (BASE FRAME).

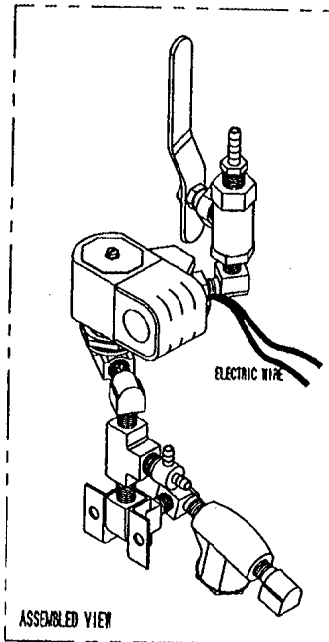
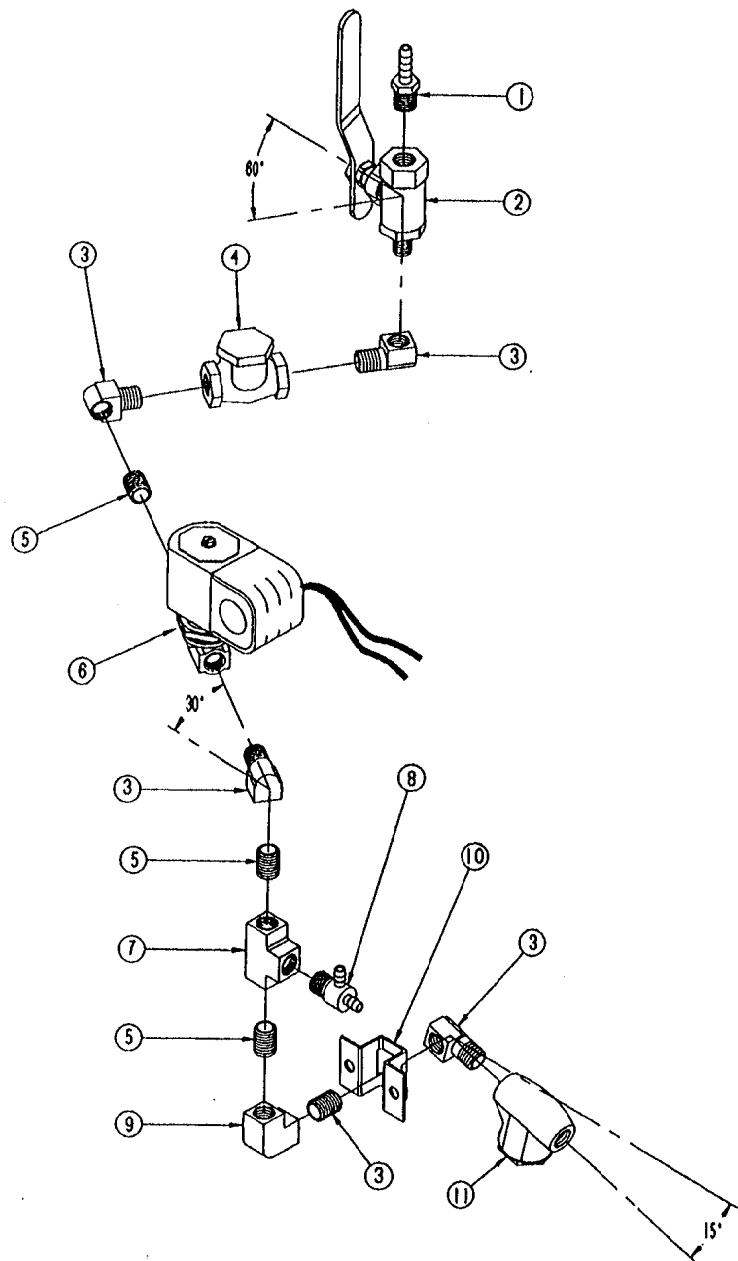

LET	REVISIONS	DATE	BY
G	ADDED 440702 PER E.O. C-1789	09-21-90	GS
H	P/N 08218 REMOVED FROM 440702 PER E.O. #C-1994	08-13-91	PJD
J	P/N 08195 REMOVED FROM 440702 PER E.O. #C-2082	11-28-91	SM
K	MOVED 440701 TO SEPERATE DRAWING	01-21-92	SM
L	NEW VALVE HOUSING ON P/N 22223 (PICTORIAL ONLY) E.O. #C-2221 R1	02-04-93	PJD
M	REMOVED ASSY 410702, P/N 104381 WAS 08218, P/N 108588 WAS 08195, PER E.O. #C-2448	08-22-93	EAG

SEE NOTE 1

- ▲▲
- ▲
- ▲▲

QTY.	ITEM	PART No.	DESCRIPTION
1	11	19870	STRAINER, "Y" 1/4"
1	10	100064	CLAMP, MOUNTING
1	9	05236	ELBOW, 1/4 90° BRASS
1	8	108588	TEE, 1/4" ROSE BARB
1	7	20199	TEE, 1/4 BRASS
1	6	22223	VALVE, SOLENOID 1/4 NPT (CP200)
4	4	14304	HIPPLE, CLOSE 1/4 BRASS
1	4	22102	VALVE, CHECK 1/4 NPT
4	3	05235	ELBOW, STREET 1/4-90° BRASS
1	2	09278	VALVE, BALL 1/4 NPT
1	1	104381	FITTING, ROSE 1/4 H X 1/4 NPT

- ▲▲▲

THIS DESIGN DESCRIBES A PROPRIETARY ITEM AND IS THE PROPERTY OF CLEVELAND RANGE. THIS DRAWING IS NOT TO BE COPIED OR USED WITHOUT THE APPROVAL OF CLEVELAND RANGE.

<b>TOLERANCES</b> <small>(EXCEPT AS NOTED)</small>			
<b>CLEVELAND RANGE INC.</b> 1339 East 179th St. Cleveland, Ohio 44110-2574			
DECIMAL ± N/A	SCALE 1/2	DRAWN BY ANDJ	APPROVED BY D.S.
ANGULAR ± 1°	TITLE PIPING ASSY., WATER FEED CONVECTION STEAMER ELECTRIC, AND GAS		
CK	DATE 09-14-90	DRAWING NO. C- 44070	REV. M

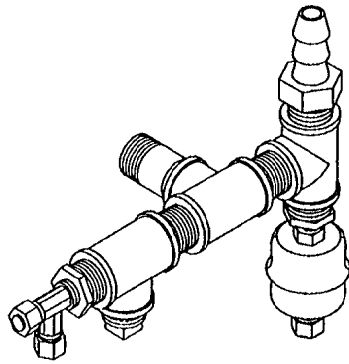

ASSEMBLED VIEW

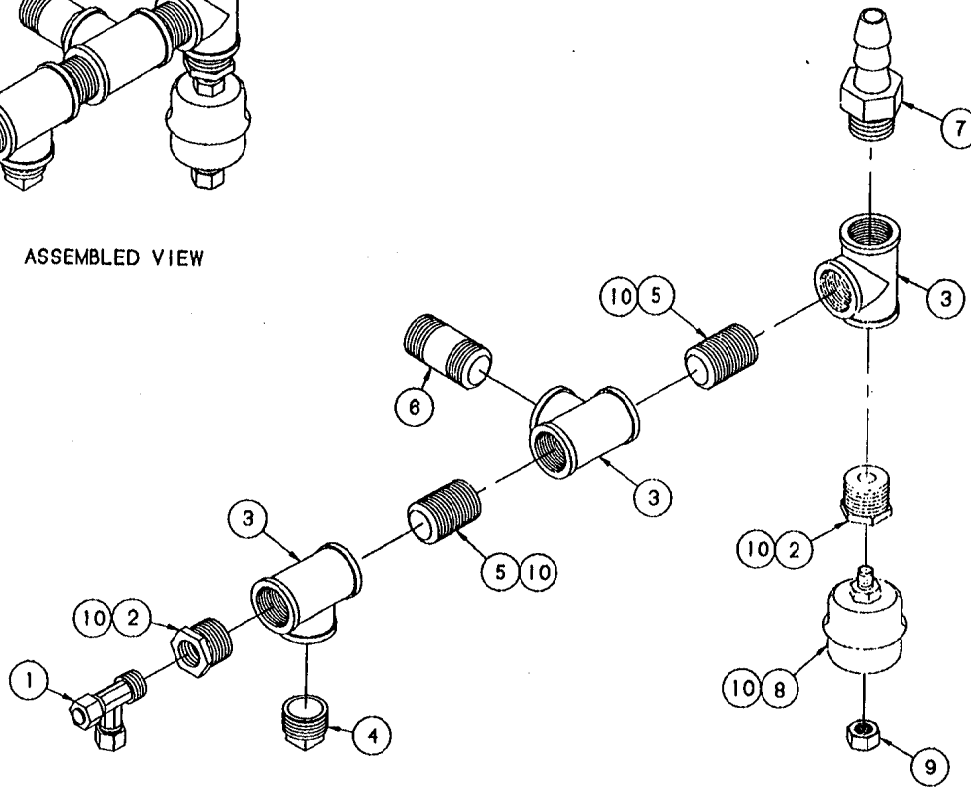

ITEM	QTY.	PART NO.	DESCRIPTION
10	A/R	00934	SEALANT, RECTORSEAL
9	1	14661	NUT, COMPRESSION, 1/4 TUBE, BRASS
8	1	101207	TRAP, THERMOSTATIC, 1/4" X 1/4"
7	1	08240	FITTING, HOSE BARB 3/4 HOSE X 3/4 NPT BRASS
6	1	14431	NIPPLE, 3/4 X 2, BRASS
5	2	14342	NIPPLE, 3/4 X CLOSE, BRASS
4	1	16607	PLUG, SQUARE HEAD, 3/4, BRASS
3	3	20208	TEE, 3/4 BRASS
2	2	02563	BUSHING, REDUCING, 3/4 X 1/4, BRASS
1	1	100883	FITTING, COMPR., TEE 3/8T X 3/8MPT X 3/8T

NEXT ASS'Y: DFE0002  
 DFF0003  
 DBE0005  
 DBF0008  
 DCE0007  
 DCF0008  
 DCE0009  
 DCF0010

THIS DESIGN DESCRIPTION IS THE PROPERTY OF CLEVELAND RANGE. THIS DRAWING IS UNLAWFULLY COPIED OR USED WITHOUT THE APPROVAL OF CLEVELAND RANGE.

PROPRIETARY ITEM  
 CLEVELAND RANGE.  
 COPIED OR USED  
 CLEVELAND RANGE.

TOLERANCES (EXCEPT AS NOTED)			
<b>CLEVELAND RANGE INC.</b> 1333 East 179th St. Cleveland, Ohio 44110-2574			
DECIMAL ± N/A	SCALE 1/2±1	DRAWN BY E. GRIVEAS	APPROVED BY NLT
ANGULAR ± N/A	TITLE STEAM OUTLET ASSEMBLY ELECTRIC GENERATOR		
CK	DATE 10-07-93	DRAWING NO. C - 428124	REV -



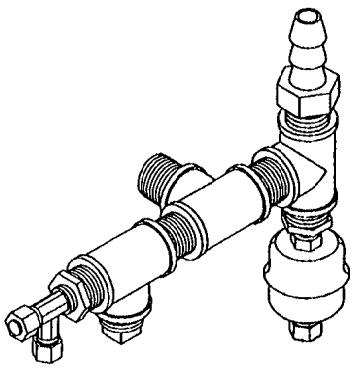

ASSEMBLED VIEW

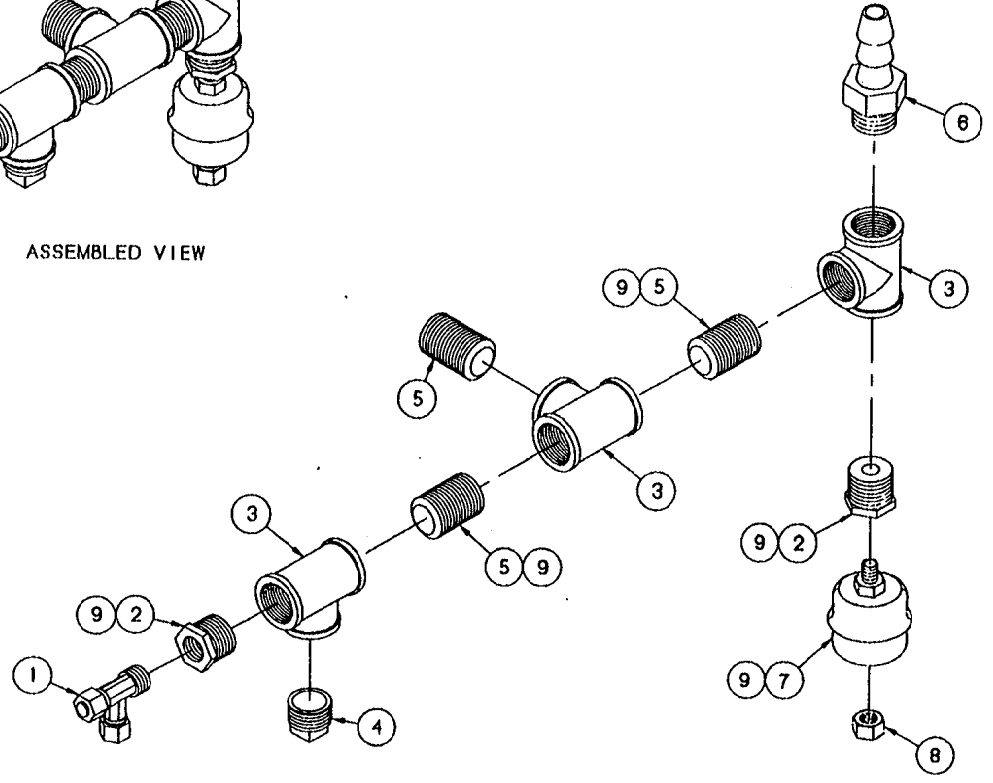

ITEM	QTY.	PART NO.	DESCRIPTION
9	A/R	00934	SEALANT, RECTORS SEAL
8	1	14661	NUT, COMPRESSION, 1/4 TUBE, BRASS
7	1	101207	TRAP, THERMOSTATIC, W/POL SEAT
6	1	08240	FITTING, HOSE BARB 3/4 HOSE X 3/4 MPT BRASS
5	3	14342	NIPPLE, 3/4 X CLOSE, BRASS
4	1	18807	PLUG, SQUARE HEAD, 3/4, BRASS
3	3	20206	TEE, 3/4 BRASS
2	2	02563	BUSHING, REDUCING, 3/4 X 1/4, BRASS
1	1	100883	FITTING, COMPR., TEE 3/8T X 3/8MPT X 3/8T

<b>TOLERANCES</b> <small>(UNLESS AS NOTED)</small>			
<b>CLEVELAND RANGE INC.</b> 1333 East 179th St. Cleveland, Ohio 44110-2574			
DECIMAL ± N/A	SCALE 1/2=1	DRAWN BY E. GRIVEAS	APPROVED BY NLT
ANGULAR ± N/A	TITLE STEAM OUTLET ASSEMBLY REV. BEND GEN., ELECTRIC		
CK	DATE 10-08-93	DRAWING NO. C - 428124	REV. -

THIS DESIGN DESCRIBES A PROPRIETARY ITEM AND IS THE PROPERTY OF CLEVELAND RANGE. THIS DRAWING IS NOT TO BE COPIED OR USED WITHOUT THE APPROVAL OF CLEVELAND RANGE.

NEXT ASS'Y: Df'D0001

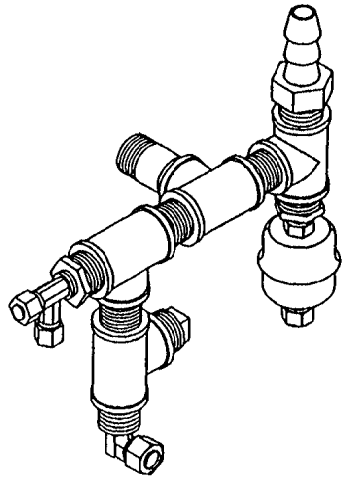

ASSEMBLED VIEW

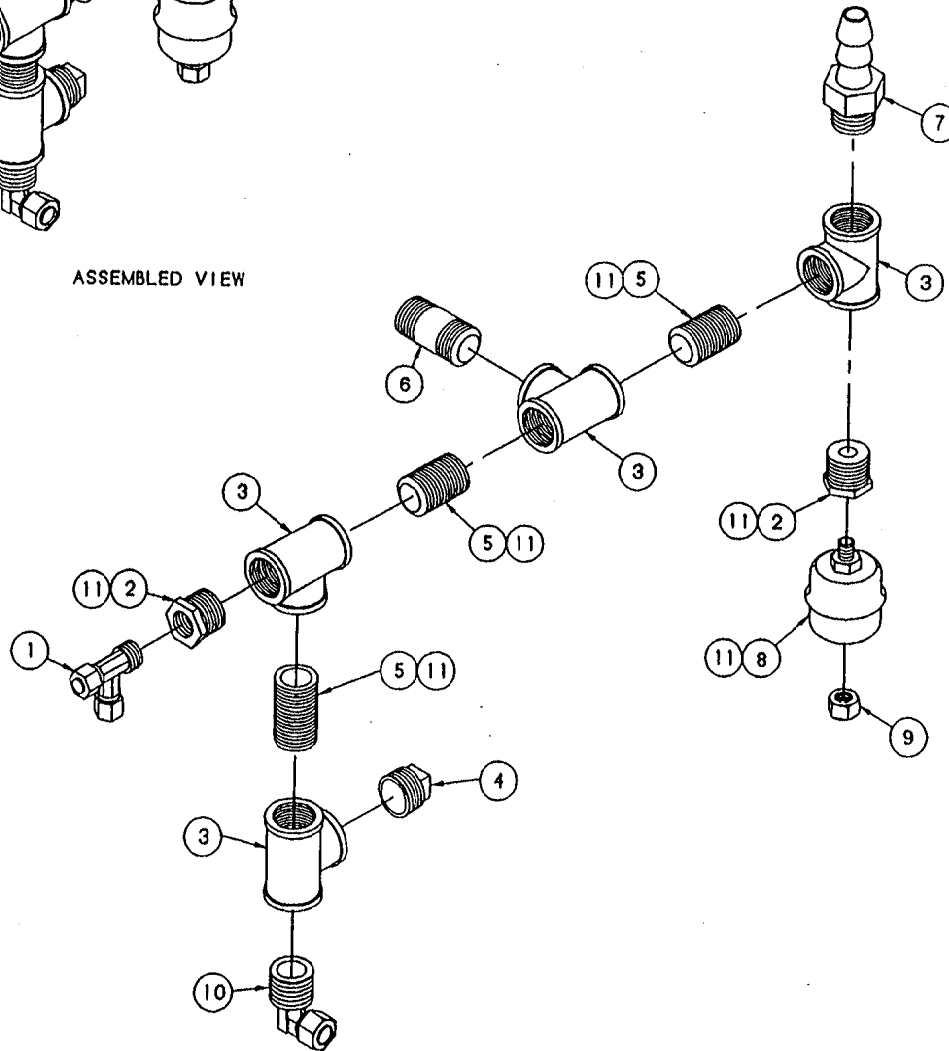

ITEM	QTY.	PART NO.	DESCRIPTION
11	A/R	00934	SEALANT, RECTORSEAL
10	1	08187	FITTING, COMPR., 90 DEG. 1/2T X 3/4MPT
9	1	14861	MUT. COMPRESSION, 1/4 TUBE, BRASS
8	1	101207	TRAP, THERMOSTATIC, 1/4" X 1/4"
7	1	06240	FITTING, HOSE BARB 3/4 HOSE X 3/4 MPT BRASS
6	1	14431	NIPLLE, 3/4 X 2, BRASS
5	3	14342	NIPLLE, 3/4 X CLOSE, BRASS
4	1	18807	PLUG, SQUARE HEAD, 3/4, BRASS
3	4	20206	TEE, 3/4 BRASS
2	2	02589	BUSHING, REDUCING, 3/4 X 1/4, BRASS
1	1	100893	FITTING, COMPR., TEE 3/8T X 3/8MPT X 3/8T

TOLERANCES (EXCEPT AS NOTED)			
<b>CLEVELAND RANGE INC.</b> 1333 East 179th St., Cleveland, Ohio 44110-2574			
DECIMAL ± N/A	SCALE 1/2=1	DRAWN BY D. DODSON	APPROVED BY NLT
ANGULAR ± N/A	TITLE STEAM OUTLET ASSY., 420KEM/420KGM REV. BEND GENERATOR		
CK	DATE 2-03-94	DRAWING NO. C - 42 - 26	REV. -

THIS DESIGN DESCRIBES A PROPRIETARY ITEM AND IS THE PROPERTY OF CLEVELAND RANGE. THIS DRAWING IS NOT TO BE COPIED OR USED WITHOUT THE WRITTEN APPROVAL OF CLEVELAND RANGE.

LET.	REVISIONS	DATE	BY
------	-----------	------	----

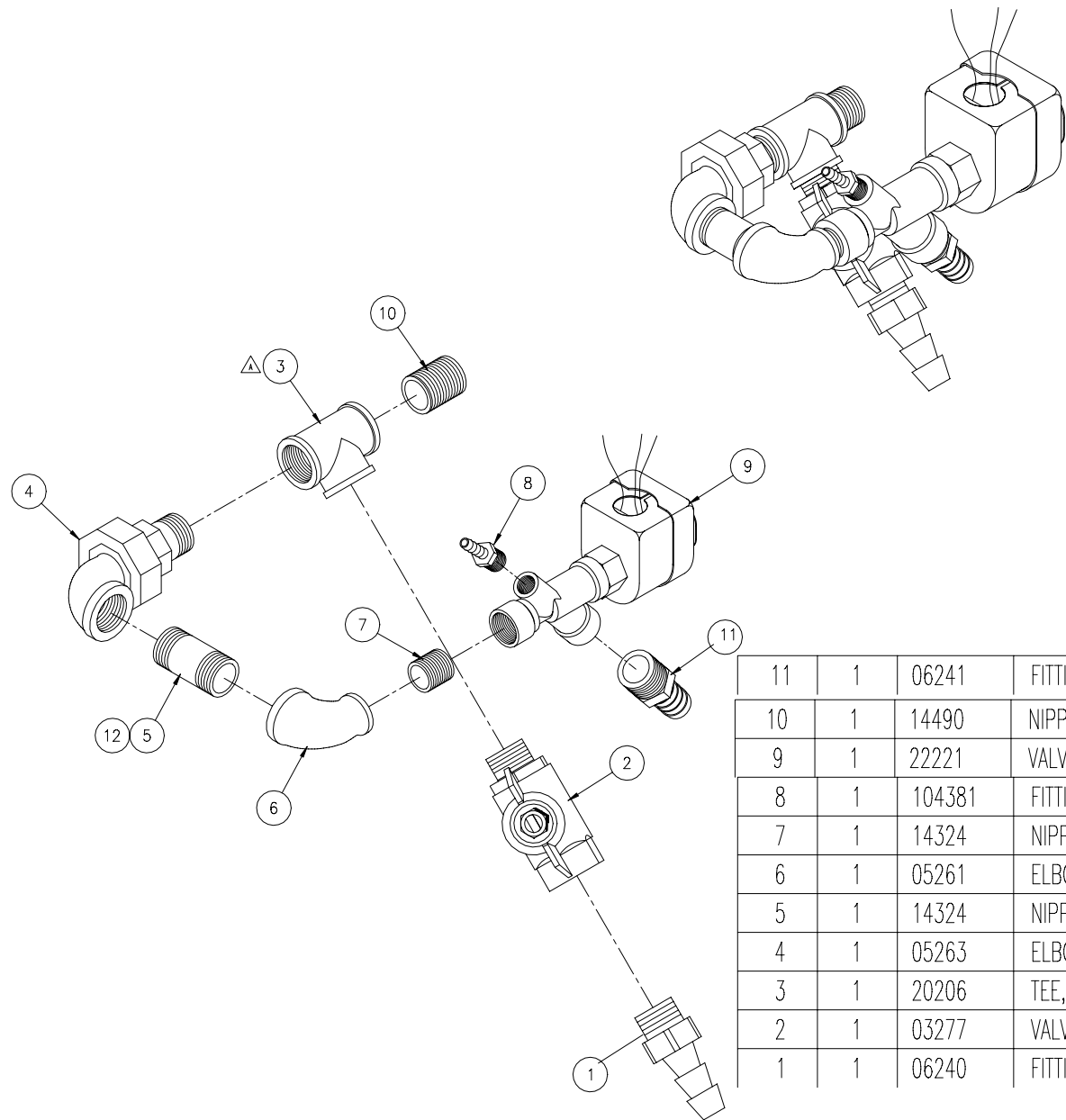

11	1	06241	FITTING, HOSE BARB, 3/4"H x 1/2"MPT
10	1	14490	NIPPLE, 3/4" x CLOSE, S/S
9	1	22221	VALVE, ASCO HV220649
8	1	104381	FITTING, HOSE BARB, 1/4"H x 1/4" NPT
7	1	14324	NIPPLE, 1/2" x CLOSE, BRASS
6	1	05261	ELBOW, 3/4" x 1/2" x 90°
5	1	14324	NIPPLE, 3/4" x 2", BRASS
4	1	05263	ELBOW, 90° RADIATOR, 3/4"
3	1	20206	TEE, 3/4", BRASS
2	1	03277	VALVE, BALL, 3/4" (W/OUT HANDLE)
1	1	06240	FITTING, HOSE BARB, 3/4"H x 3/4" MPT

ITEM	QTY	PART NO.	DESCRIPTION
<b>CLEVELAND RANGE, LLC</b>			
1333 East 179th St., Cleveland, Ohio 44110-2574			
<small>THIS DESIGN DESCRIBES A PROPRIETARY ITEM AND IS THE PROPERTY OF CLEVELAND RANGE. THIS DRAWING IS NOT TO BE COPIED OR USED WITHOUT THE APPROVAL OF CLEVELAND RANGE.</small>			
TOLERANCES (UNLESS OTHERWISE NOTED)	DO NOT SCALE PRINTED DRAWING	DRAWN BY S.MILEWSKI	DATE 7-18-91
DECIMAL ±.030	TITLE PIPING ASSEMBLY, BLOWDOWN 600 MM, GAS		
ANGULAR ± 1°	SIZE C	DRAWING NO. 40811	SHEET 1 OF 1 REV J

NOTE: ROTATE VALVE ABOUT 45° FOR J PRESUURE BASES.

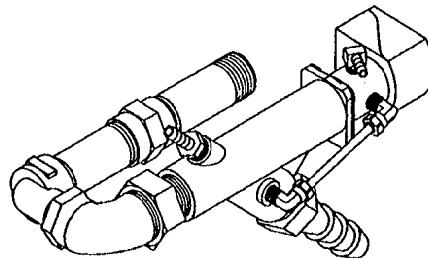
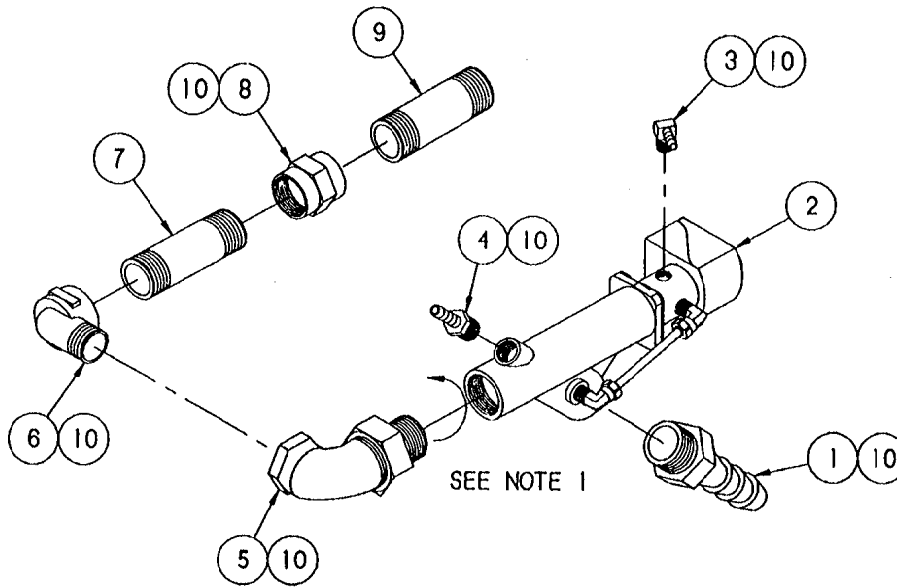

LET.	REVISIONS	DATE	BY
A	REMOVED P/N'S 03851, 14329 (2), 05284 ADDED 08241	3-27-92	SM
B	P/N 08240 WAS 08241, P/N 22244 WAS 22221, P/N 104381 WAS 08218, P/NS 105787, 14348 & 03812 ADDED, P/NS 14324, 02588, 20208, 14342, 03277 & 08323 OMITTED PER E.O. #C-2148	08-18-93	PJD

NO.	QTY.	PART NO.	DESCRIPTION
10		00934	SEALANT, RECTORSEAL
9	1	14495	NIPPLE, 3/4 NPT X 3", S/S
⚠ 8	1	03812	COUPLING, FULL, 3/4, BRASS
⚠ 7	1	14348	NIPPLE, 3/4 X 3, BRASS
6	1	05291	ELBOW, STREET, 3/4 X 90°, FORGED BRASS
5	1	05283	ELBOW, UNION RADIATOR, 3/4 X 90°
⚠ 4	1	104381	FITTING, HOSE BARB, 1/4 H X 1/4 MPT
⚠ 3	1	105787	FITTING, HOSE BARB, 1/4 H X 1/8 MPT 90°
⚠ 2	1	22244	VALVE, SOLENOID, 1/2", 15 PSI
⚠ 1	1	08240	FITTING, HOSE BARB, 3/4 H X 3/4 MPT

TOLERANCES (EXCEPT AS NOTED)		CLEVELAND RANGE INC.	
DECIMAL	SCALE	1333 East 179th St. Cleveland, Ohio 44110-2574	
± N/A	1/2±1	DRAWN BY	APPROVED BY
ANGULAR		S. MILEWSKI	MLT
± N/A		TITLE	
		PIPING ASSEMBLY, BLOWDOWN 24CEM, ELECTRIC "J's"	
CK	DATE	DRAWING NO.	REV.
	03-28-92	C - 40889	8

THIS DESIGN DESCRIBES A PROPRIETARY ITEM AND IS THE PROPERTY OF CLEVELAND RANGE. THIS DRAWING IS NOT TO BE COPIED OR USED WITHOUT THE APPROVAL OF CLEVELAND RANGE.

LET.	REVISIONS	DATE	BY
A	ADDED P/N'S 03818 & 08240	3-27-92	SM
B	ADDED P/N 19917 EO #C-2267	8-16-92	SM
C	P/N 18808 WAS 08208 PER E.O. #C-2448	8-22-93	PD

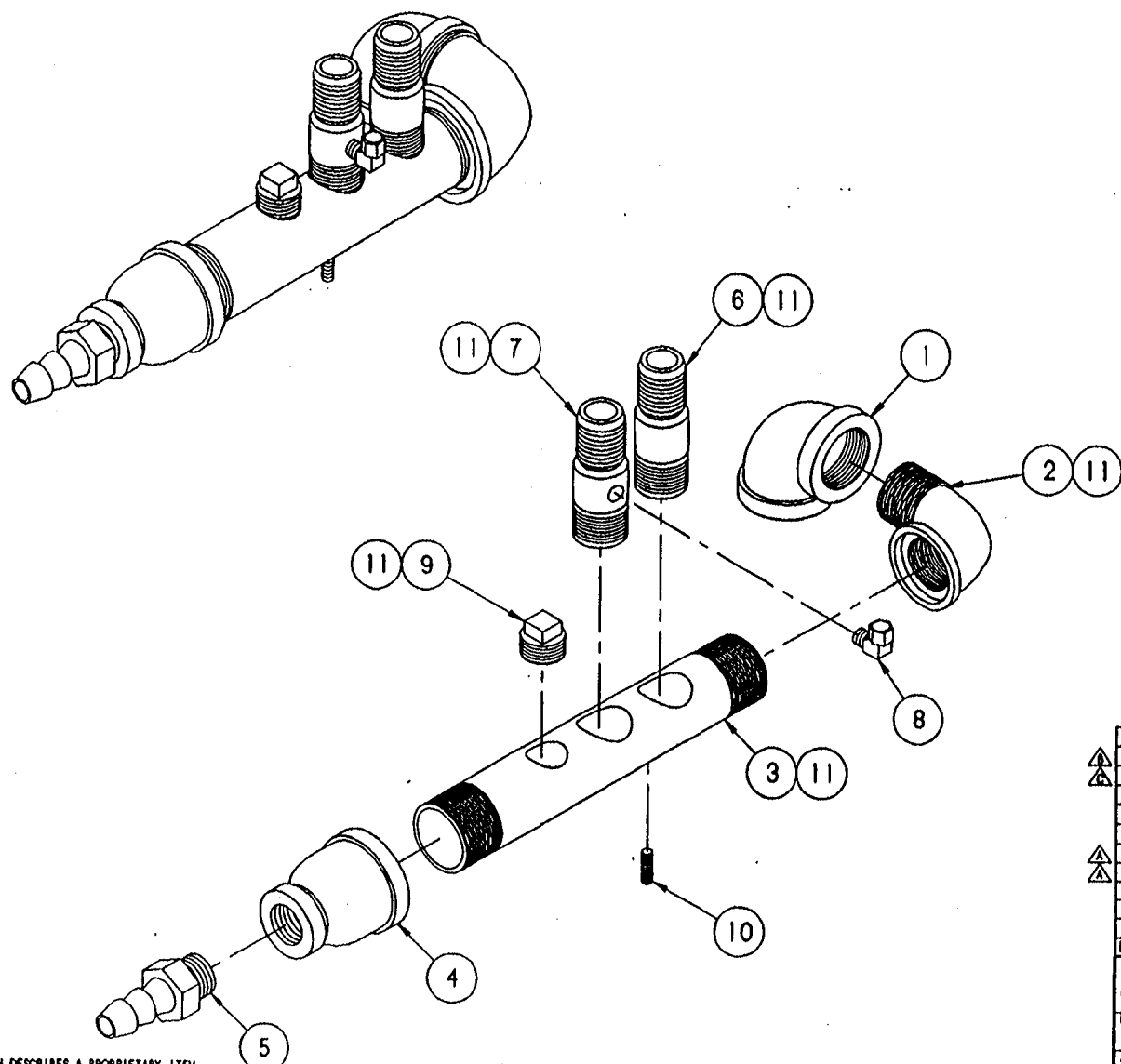

THIS DESIGN DESCRIBES A PROPRIETARY ITEM AND IS THE PROPERTY OF CLEVELAND RANGE. THIS DRAWING IS NOT TO BE COPIED OR USED WITHOUT THE APPROVAL OF CLEVELAND RANGE.

11	A/R	00934	SEALANT, RECTORSEAL
10	I	19917	STUD, ARC WELD, 1/4-20 x .875, S/S
9	I	18808	PLUG, SQUARE HEAD, 3/4" PIPE, BLACK
8	I	08192	FITTING, COMP, 1/4 T x 1/8 MPT, 90°
7	I	585191	FITTING, HOSE BARB, 1" w/ 1/8" HOLE
6	I	14481	FITTING, HOSE BARB, 1" H x 1" NPT
5	I	08240	FITTING, HOSE BARB, 3/4 H x 3/4 MPT
4	I	03818	COUPLING, REDUC., 1-1/2 x 3/4, BLK
3	I	13252	MANIFOLD, DRAIN, 1-1/2, BLACK
2	I	05292	ELBOW, STREET, 1-1/2, 90°, BLACK
1	I	05238	ELBOW, 1-1/2 NPT, 90°, BLACK
ITEM	QTY.	PART NO.	DESCRIPTION
TOLERANCES			<b>CLEVELAND RANGE INC.</b> 1333 East 179th St., Cleveland, Ohio 44110-2574
FRACTIONS AS SHOWN			
DECIMAL	SCALE	DRAWN BY	APPROVED BY
± N/A	9/16=1	S. MILEWSKI	
ANGULAR	TITLE	DRAIN MANIFOLD ASSEMBLY	
± N/A		24CEM	
CK	DATE	DRAWING NO.	REV.
	03-28-92	C - 42749	C

LET.	REVISIONS	DATE	BY
-	PRODUCTION RELEASE E.O. 1C-1994	08-23-91	P.J.D.
A	P/N 14347 & 20205 OMITTED AND P/N 08240 WAS QTY. OF 2 PER E.O. 1C-2448	08-22-93	P.J.D.

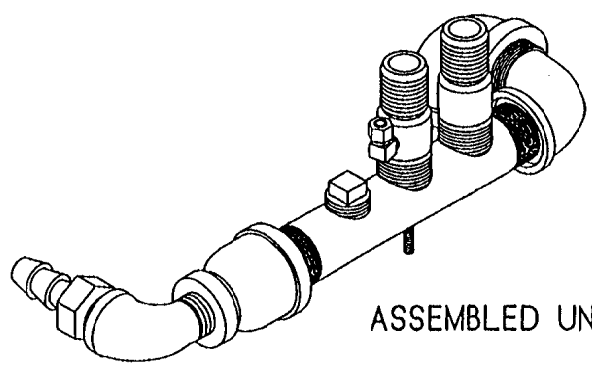
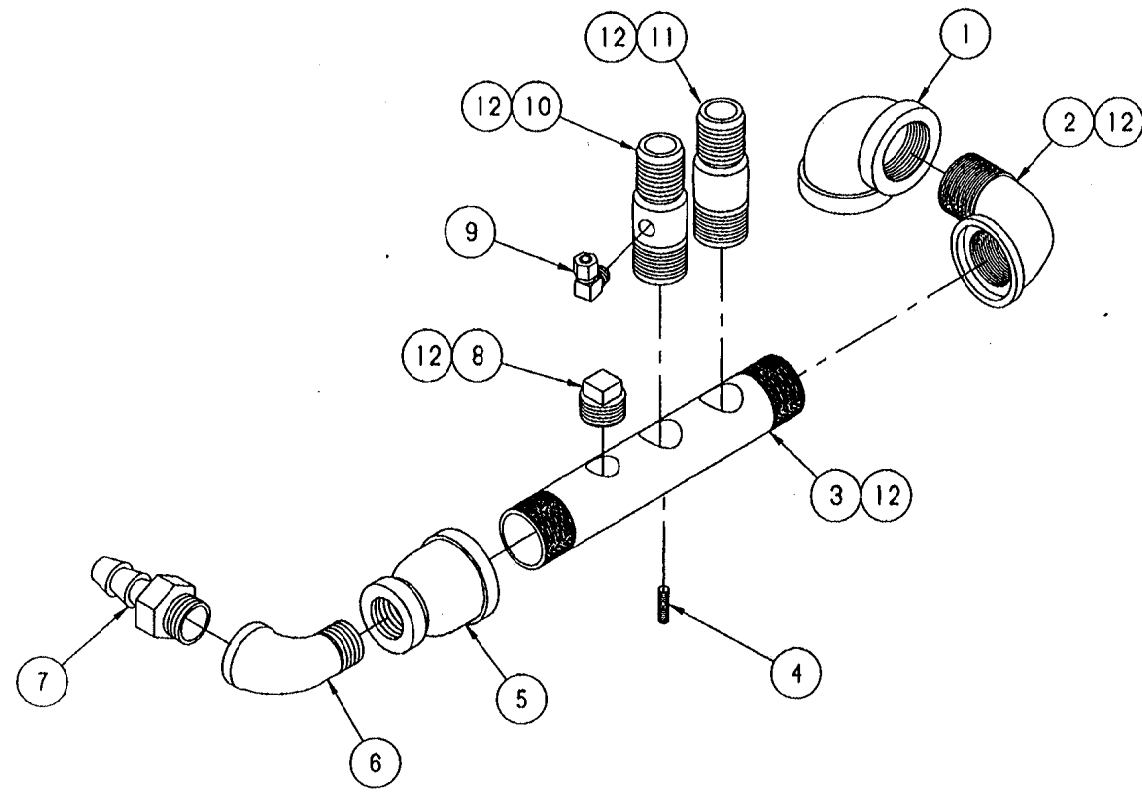

ASSEMBLED UNIT

ITEM	QTY.	PART NO.	DESCRIPTION
12	A/R	00934	SEALANT, RECTORSEAL
11	1	14481	FITTING, BARB 1" H X 1" MPT S/S
10	1	585191	FITTING, HOSE, DRAIN MANIFOLD W/ 1/8 HOLE
9	1	08192	FITTING, COMP. 1/4 T X 1/8 MPT 90°
8	1	18808	PLUG, SQ. HEAD, 3/4" PIPE, BLACK
7	1	08240	FITTING, HOSE BARB 3/4 H X 3/4 MPT
6	1	05259	ELBOW, STREET 3/4 X 90°, BLACK
5	1	03818	COUPLING, RED. 1-1/2 X 3/4, BLACK
4	1	19917	STUD, WELD 1/4-20 X 7/8, S/S
3	1	13252	MANIFOLD, DRAIN 1-1/2 NPT, BLACK
2	1	05292	ELBOW, STREET 1-1/2 NPT X 90° BLACK
1	1	05238	ELBOW, 1-1/2 NPT X 90°, BLACK

TOLERANCES (EXCEPT AS NOTED)		<b>CLEVELAND RANGE INC.</b> 1333 East 179th St. Cleveland, Ohio 44110-2574	
DECIMAL ± N/A	SCALE 1/2"	DRAWN BY P.J.D.	APPROVED BY
ANGULAR ± N/A	TITLE PIPING ASSEMBLY, DRAIN 38CGM/SM, 38CGM/LG, 38CEM, 24CSM, 38CSM		
CK	DATE 08-13-91	DRAWING NO. C - 42751	REV. A

THIS DESIGN DESCRIBES A PROPRIETARY ITEM AND IS THE PROPERTY OF CLEVELAND RANGE. THIS DRAWING IS NOT TO BE COPIED OR USED WITHOUT THE APPROVAL OF CLEVELAND RANGE.