



**Oil Conserving Fryer (OCCF30)<sup>TM</sup>**  
**GAS FRYERS**  
**Service & Parts Manual**



**FRYMASTER<sup>®</sup>**



Frymaster, a member of the Commercial Food Equipment Service Association, recommends using CFESA Certified Technicians.

**24-Hour Service Hotline 1-800-551-8633**

**02/2020**

[www.frymaster.com](http://www.frymaster.com)

E-mail: [fryservice@welbilt.com](mailto:fryservice@welbilt.com)



8 1 9 6 6 8 8

**NOTICE**

IF, DURING THE WARRANTY PERIOD, THE CUSTOMER USES A PART FOR THIS FRYMASTER EQUIPMENT OTHER THAN AN UNMODIFIED NEW OR RECYCLED PART PURCHASED DIRECTLY FROM FRYMASTER DEAN, OR ANY OF ITS FACTORY AUTHORIZED SERVICERS, AND/OR THE PART BEING USED IS MODIFIED FROM ITS ORIGINAL CONFIGURATION, THIS WARRANTY WILL BE VOID. FURTHER, FRYMASTER DEAN AND ITS AFFILIATES WILL NOT BE LIABLE FOR ANY CLAIMS, DAMAGES OR EXPENSES INCURRED BY THE CUSTOMER WHICH ARISE DIRECTLY OR INDIRECTLY, IN WHOLE OR IN PART, DUE TO THE INSTALLATION OF ANY MODIFIED PART AND/OR PART RECEIVED FROM AN UNAUTHORIZED SERVICE CENTER.

**NOTICE**

This appliance is intended for professional use only and is to be operated by qualified personnel only. A Frymaster Factory Authorized Servicer (FAS) or other qualified professional should perform installation, maintenance, and repairs. Installation, maintenance, or repairs by unqualified personnel may void the manufacturer's warranty. See Chapter 1 of this manual for definitions of qualified personnel.

**NOTICE**

This equipment must be installed in accordance with the appropriate national and local codes of the country and/or region in which the appliance is installed. See NATIONAL CODE REQUIREMENTS in Chapter 2 of this manual for specifics.

**NOTICE TO U.S. CUSTOMERS**

This equipment is to be installed in compliance with the basic plumbing code of the Building Officials and Code Administrators International, Inc. (BOCA) and the Food Service Sanitation Manual of the U.S. Food and Drug Administration.

**NOTICE**

Drawings and photos used in this manual are intended to illustrate operational, cleaning and technical procedures and may not conform to onsite management operational procedures.

**NOTICE TO OWNERS OF UNITS EQUIPPED WITH COMPUTERS**

**U.S.**

This device complies with Part 15 of the FCC rules. Operation is subject to the following two conditions: 1) This device may not cause harmful interference, and 2) This device must accept any interference received, including interference that may cause undesired operation. While this device is a verified Class A device, it has been shown to meet the Class B limits.

**CANADA**

This digital apparatus does not exceed the Class A or B limits for radio noise emissions as set out by the ICES-003 standard of the Canadian Department of Communications.

Cet appareil numérique n'émet pas de bruits radioélectriques dépassant les limites de classe A et B prescrites dans la norme NMB-003 édictée par le Ministre des Communications du Canada.

** DANGER**

Improper installation, adjustment, maintenance or service, and unauthorized alterations or modifications can cause property damage, injury, or death. Read the installation, operating, and service instructions thoroughly before installing or servicing this equipment. Only qualified service personnel may convert this appliance to use a gas other than that for which it was originally configured.

**⚠ DANGER**

No structural material on the fryer should be altered or removed to accommodate placement of the fryer under a hood. Questions? Call the Frymaster Dean Service Hotline at 1-800-551-8633.

**⚠ DANGER**

Adequate means must be provided to limit the movement of this appliance without depending upon the gas line connection. Single fryers equipped with legs must be stabilized by installing anchor straps. All fryers equipped with casters must be stabilized by installing restraining chains. If a flexible gas line is used, an additional restraining cable must be connected at all times when the fryer is in use.

**⚠ DANGER**

The front ledge of the fryer is not a step! Do not stand on the fryer. Serious injury can result from slips or contact with the hot oil.

**⚠ DANGER**

Do not store or use gasoline or other flammable liquids or vapors in the vicinity of this or any other appliance.

**⚠ DANGER**

Instructions to be followed in the event the operator smells gas or otherwise detects a gas leak must be posted in a prominent location. This information can be obtained from the local gas company or gas supplier.

**⚠ DANGER**

This product contains chemicals known to the state of California to cause cancer and/or birth defects or other reproductive harm.

Operation, installation, and servicing of this product could expose you to airborne particles of glasswool or ceramic fibers, crystalline silica, and/or carbon monoxide. Inhalation of airborne particles of glasswool or ceramic fibers is known to the State of California to cause cancer. Inhalation of carbon monoxide is known to the State of California to cause birth defects or other reproductive harm.

**⚠ DANGER**

The crumb tray in fryers equipped with a filter system must be emptied into a fireproof container at the end of frying operations each day. Some food particles can spontaneously combust if left soaking in certain shortening material.

**⚠ WARNING**

Do not bang fry baskets or other utensils on the fryer's joiner strip. The strip is present to seal the joint between the fry vessels. Banging fry baskets on the strip to dislodge shortening will distort the strip, adversely affecting its fit. It is designed for a tight fit and should only be removed for cleaning.

**NOTICE**

The Commonwealth of Massachusetts requires any and all gas products to be installed by a licensed plumber or pipe fitter.

# OCF30™ SERIES GAS FRYERS

## TABLE OF CONTENTS

<b>CAUTIONARY STATEMENTS</b> .....	i
<b>CHAPTER 1: Service Procedures</b>	
1.1 Functional Description .....	1-1
1.2 The Electronic Ignition System .....	1-1
1.3 Interface Board .....	1-2
1.4 Thermostats .....	1-4
1.5 Accessing Fryers for Servicing.....	1-4
1.6 Cleaning the Gas Valve Vent Tube .....	1-5
1.7 Checking the Burner Manifold Gas Pressure .....	1-5
1.8 Measuring Flame Current.....	1-6
1.9 Replacing Fryer Components .....	1-7
1.9.1 Replacing the Controller or the Controller Wiring Harness.....	1-7
1.9.2 Replacing the Temperature Probe or High-Limit Thermostat .....	1-7
1.9.3 Replacing the Interface Board.....	1-8
1.9.4 Replacing an Ignition Module.....	1-8
1.9.5 Replacing an Ignitor Assembly .....	1-8
1.9.6 Replacing or Cleaning a Combustion Air Blower.....	1-9
1.9.7 Adjusting the Air/Gas Mixture.....	1-10
1.9.8 Replacing a Gas Valve .....	1-11
1.9.9 Replacing a Burner Assembly .....	1-12
1.9.10 Replacing the Filter Motor, Filter Pump, or Filter Pump Solenoid Valve .....	1-13
1.9.11 Replacing the Frypot .....	1-13
1.9.12 Replacing Frypot Insulation and/or Upper Burner Rails.....	1-14
1.10 Troubleshooting and Problem Isolation .....	1-17
1.10.1 Ignition Failure.....	1-18
1.10.2 Improper Burner Function.....	1-18
1.10.3 Improper Temperature Control .....	1-20
1.10.4 Computer Malfunction .....	1-20
1.10.5 Filtration Malfunction .....	1-20
1.10.6 Leakage .....	1-21
1.10.7 Basket Lift Malfunction .....	1-21
1.11 Troubleshooting Guides .....	1-23
1.11.1 Troubleshooting the 24 VAC Circuit.....	1-23
1.11.2 Troubleshooting the Gas Valve.....	1-26
1.11.3 Troubleshooting the Temperature Probe .....	1-27
1.11.4 Replacing the Transformer, Reset Switch or Filter Relay.....	1-27
1.12 Probe Resistance Chart.....	1-28
1.13 ATO (Automatic Top-Off) Service Procedures .....	1-28
1.13.1 ATO (Automatic Top-Off) Troubleshooting.....	1-28
1.13.2 ATO (Automatic Top-Off) Board Positions and Harnesses.....	1-31
1.13.3 Replacing the ATO Board, Pump Relay or Transformer .....	1-32
1.13.4 Replacing the ATO Pump .....	1-32
1.13.5 Replacing the ATO Solenoid .....	1-32
1.13.6 Control Power Reset.....	1-33
1.13.7 Testing ATO RTD Probes.....	1-33
1.13.8 Replacing ATO Probe .....	1-33
1.14 3000 Computer Service Procedures .....	1-33
1.14.1 3000 Computer Troubleshooting .....	1-33
1.14.2 3000 Useful Codes and Passwords.....	1-36

**OCF30™ SERIES GAS FRYERS**  
**TABLE OF CONTENTS cont.**

---

1.14.3	Service required Errors.....	1-36
1.14.4	Error Log Codes .....	1-37
1.14.5	3000 Menu Summary Tree.....	1-38
1.14.6	3000 Controller Pin Positions and Harnesses.....	1-39
1.15	Loading and Updating Software Procedures .....	1-40
1.16	Principal Wiring Connections .....	1-41
1.17	Wiring Diagrams .....	1-42
1.17.1	FPGL230/430 Wiring 120V, CE and Export .....	1-42
1.17.1.2	FPGL230/430 Wiring 250V Australia .....	1-43
1.17.2	FPGL330 Wiring 120V, CE and Export .....	1-44
1.17.2.2	FPGL330 Wiring 120V, CE Australia .....	1-45
1.17.3	FPGL430 Wiring.....	1-46
1.17.4	Modular Basket Lift (100/120V).....	1-47
1.17.5	Modular Basket Lift (208/250V).....	1-48
1.17.6	Basket Lift Interface Wiring .....	1-49
1.18	Simplified Wiring Diagrams .....	1-50
1.18.1	FPGL30 Full-Vat Dual-Spark Module .....	1-50
1.18.2	FPGL30 Full-Vat Single-Spark Module .....	1-51
1.18.3	FPGL30 Dual-Vat Single-Spark Module .....	1-52
1.18.4	FPGL30 Series Simplified Wiring .....	1-53
1.18.5	FPGL30 Series Data Network Flowchart.....	1-54
1.18.6	Shortening Melting Unit Wiring Diagram prior to Mar 2012.....	1-55
1.18.6.2	Shortening Melting Unit Wiring Diagram after to Mar 2012 .....	1-56
1.18.7	Bulk Oil Wiring Diagram 120V, CE and Export .....	1-57
1.18.7.1	FPGL230/430 Wiring 120V, CE and Export Bulk Oil .....	1-57
1.18.7.2	FPGL230/430 Wiring 250V Australia Bulk Oil .....	1-58
1.18.7.3	FPGL330 Wiring 120V, CE and Export Bulk Oil .....	1-59
1.18.7.4	FPGL330 Wiring 250V Australia Bulk Oil .....	1-60
1.18.8	Bulk Oil Box Wiring Diagram .....	1-61
1.19	Capable Controls Ignition Module Wiring Diagrams .....	1-62

**CHAPTER 2: Parts List**

2.1	Accessories .....	2-1
2.2	Basket Lift Assemblies and Associated Parts.....	2-2
2.3	Doors, Sides, Flue Caps, Top Caps and Casters.....	2-4
2.4	Drain System Components .....	2-5
2.4.1	Drain Valves and Associated Parts .....	2-5
2.4.2	Drain Tube Sections and Associated Parts.....	2-6
2.5	Electronics and Electrical Components.....	2-7
2.5.1	Computers and Associated Components .....	2-7
2.5.2	Component Boxes .....	2-8
2.5.3	Transformer Boxes.....	2-10
2.6	Wiring.....	2-12
2.6.1	Main Wiring Harnesses.....	2-12
2.6.2	3000 and ATO Wiring Harnesses .....	2-13
2.7	Frypots and Associated Components .....	2-14
2.7.1	Full-Vat Frypot Components .....	2-14
2.7.2	Dual-Vat Frypot Components .....	2-16
2.7.3	Frypot Probes and Thermostats.....	2-18
2.8	Gas Valves, Supply and Combustion System Components .....	2-19
2.9	Filtration System Components .....	2-21

2.10	Filter Pump, Motor and Associated Components.....	2-22
2.11	Frypot Assemblies and Associated Components.....	2-23
2.12	Oil Return System Components .....	2-24
2.13	ATO (Auto Top-Off) Components.....	2-25
2.13.1	ATO Box Assembly .....	2-25
2.13.2	JIB (Jug In Box) Cradle, JIB Cap and Pick Up Assembly .....	2-25
2.13.3	ATO (Automatic Top-Off) Pump Assembly .....	2-26
2.13.4	ATO Top off Manifolds and Components.....	2-27
2.13.5	Shortening Melting Unit.....	2-28
2.13.6	Bulk Oil Relay Box and Switch .....	2-29
2.13.7	Bulk Oil Plumbing.....	2-30
2.13.8	Bulk Oil Dispose Waste Valve.....	2-31
2.14	Wiring Connectors, Pin Terminals, and Tools .....	2-32
2.15	Fasteners .....	2-33

# OCF30™ SERIES GAS FRYER

## CHAPTER 1: SERVICE PROCEDURES

### 1.1 Functional Description

OCF30™ series gas fryers contain a welded stainless steel frypot that is directly heated by a high efficiency infrared burner system, requiring approximately 43% less energy than conventional burners to cook the same volume.

Self-contained combustion chambers (referred to as “burners”) are fitted into rails attached to the sides of the frypot, one on each side. Each combustion chamber is fitted with special ceramic tiles that are heated by the burning of a forced air/gas mixture. The tiles transfer heat to the frypot by means of infrared radiation, providing much more constant and uniform heat dispersion over the surface of the frypot than do conventional burners. Because less heat is lost to the atmosphere in the process, compared to “open-burner” designs, less fuel is required to achieve and maintain a given frypot temperature.

In full-vat units, gas flow to both of the burners is regulated by one electromechanical gas valve. All fryers in this series are equipped with 24 VAC gas valve systems, and all are configured with electronic ignition.

### 1.2 The Electronic Ignition System

An ignition module mounted below the component box (located behind the control panel) is connected to an ignitor assembly at the burner. The ignition module performs five important functions: it provides fuse protection for the 24-volt circuit, provides an ignition spark, supplies voltage to the gas valve, provides the alarm circuit (24V) to the controller and proofs the burner flame. The module contains a four second time delay circuit and a coil that activates the gas valve. Three types are in use. A closed-box design is used in most fryers, but in some fryers built for export, the module resembles an interface board. A single dual-spark module is used on current production full-vat fryers.

The ignitor assembly consists of a spark plug, an enrichment tube, and a flame sensor.

At start-up, the power switch is placed in the ON position, supplying approximately 12-volts DC to the heat-control circuitry in the controller and to one side of the heat relay coils on the interface board. If resistance in the temperature probe indicates the temperature in the frypot is below 180°F (82°C), the current flows through a melt cycle circuit where a timer switch alternately closes for six seconds and opens for 24 seconds. If the temperature is 180°F (82°C) or above, the current flows through a heat circuit, bypassing the timer switch. In either case, ground is supplied to the other leg of the heat relay coils, which closes electronic switches in the 24 VAC circuit to provide current to the ignition module. Circuitry in the ignition module sends 24 VAC to the gas valve via a normally closed high-limit switch and a normally closed drain safety switch. Simultaneously, the module causes the ignitor to spark for four seconds to light the burner. A flame sensor verifies the burner ignition by measuring the flow of microamps through the flame. If the burner does not light (or is extinguished), current to the ignition module is cut, the gas valve closes, and the ignition module “locks out” until the power switch is turned off and then back on. A probe monitors the temperature in the frypot. When the programmed setpoint temperature is reached, resistance in the probe causes the heat cycle circuitry in the controller to cut off current flow through the heat relay. This in turn cuts off the 24 VAC to the ignition module, causing the gas valve to close.

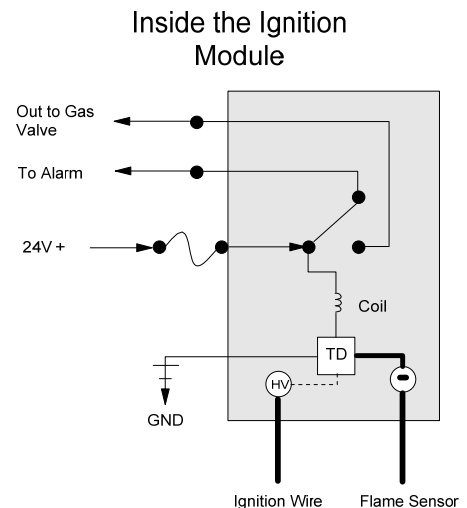

### 1.3 Interface Board

All fryers in this series have an interface board located in the component box behind the control panel. The interface board provides a link between the controller and the fryer's individual components without requiring excessive wiring, and allows the controller to execute commands from one central point.

K2 and K3 are double-pole-double throw (DPDT) relays that supply 24VAC to the ignition and gas valve circuits, as well as 120VAC to the blower motor. The relays on this board plug into sockets. If a relay fails, that relay can be replaced.

LEDs (labeled D1 through D7) are arrayed around the board to assist in troubleshooting.

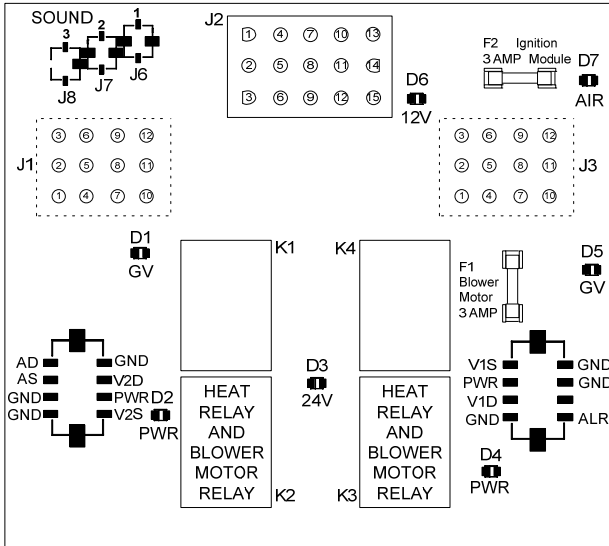

SMT INTERFACE BOARD KIT 826-2264 (106-6706)

INTERFACE BOARD LED DIAGNOSTIC LIGHTS	
D1	24 VAC to left gas valve (dual vat only)
D2	24 VAC to left ignition module (dual vat only)
D3	24 VAC from transformer
D4	24 VAC to right ignition module
D5	24 VAC to gas valve (right valve if dual vat)
D6	12 VAC from transformer
D7	CE and Japanese units only: air switch closed

**NOTE:** In full-vat fryers, the relay for the left side (K2) may not be present.

The chart on the following page illustrates current flow through the board, and the table at the top of page 1-4 identifies frequently used test points.



# INTERFACE BOARD

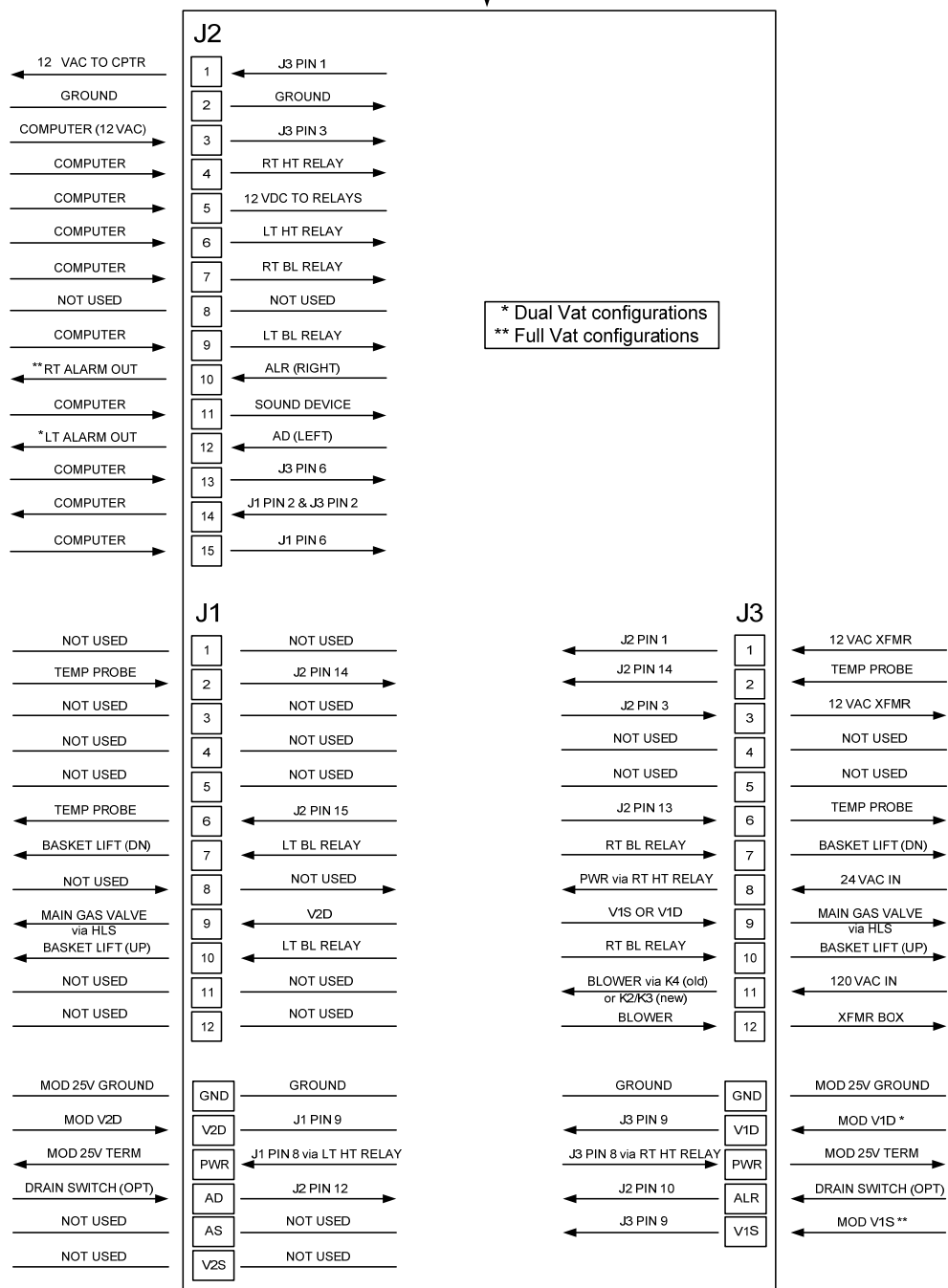

LEFT VAT

FULL OR RIGHT VAT

## CURRENT FLOW THROUGH INTERFACE BOARD 106-6706 (SMT HE SERIES APPLICATION)

## FREQUENTLY USED TEST POINTS FOR INTERFACE BOARD 106-6706

TEST	METER SETTING	PINS	RESULTS
12VAC Power to Controller	50VAC Scale	1 and 3 on J3 or J2	12-18
24VAC Power to Right Module	50VAC Scale	8 on J3 and GROUND	22-28
120 VAC Power	250VAC Scale	11 on J3 and GROUND	110-125
120 VAC Power to Blowers	250VAC Scale	12 on J3 and GROUND	110-125
24VAC Power to Full or Right vat High-Limit	50VAC Scale	9 on J3 and GROUND	22-28
24VAC Power to Left High-Limit (if present)	50VAC Scale	9 on J1 and GROUND	22-28
Probe Resistance (Full or Right Vat) *	R x 1000 OHMS	2 and 6 on J3 or 13 and 14 on J2	**
Probe Resistance (Left - if present) *	R x 1000 OHMS	2 and 6 on J1 or 14 and 15 on J2	**
Probe Isolation	R x 1000 OHMS	6 on J1 or J3 and GROUND	***
High-Limit Continuity (Full or Right Vat)	R x 1 OHM	9 on J3 and Wire 13C on Gas Valve	0
High-Limit Continuity (Left - if present)	R x 1 OHM	9 on J1 and Wire 12C on Gas Valve	0
<p>* <b>Disconnect 15-pin harness from controller before testing probe circuit.</b></p> <p>** <b>See Probe Resistance Chart on page 1-28.</b></p> <p>*** <b>5 mega-Ohms or greater.</b></p>			

### 1.4 Thermostats

OCF30™ series gas fryers have *temperature probes* located on the front centerline of each frypot. In this type of thermostat, the probe resistance varies directly with the temperature. That is, as the temperature rises, so does resistance, at a rate of approximately 2 ohms for every 1° F. Circuitry in the controller monitors the probe resistance and controls burner firing when the resistance exceeds or falls below programmed temperatures (setpoints).

OCF30™ series gas fryers are also equipped with a *high-limit thermostat*. In the event that the fryer fails to properly control the oil temperature, the high-limit thermostat prevents the fryer from overheating to the flash point. The high-limit thermostat acts as a normally closed power switch that opens when exposed to temperatures above 425°F to 450°F (218°C to 232°C). The different types of thermostats have different part numbers for CE and Non-CE models, and are not interchangeable.

### 1.5 Accessing Fryers for Servicing

#### DANGER

**Moving a fryer filled with oil may cause spilling or splattering of the hot liquid. Follow the draining instructions in Chapter 5 of the OCF30™ Series Gas Fryer Installation and Operation Manual (P/N 819-6687) before attempting to relocate a fryer for servicing.**

1. Shut off the gas supply to the unit. Unplug the power cords. Disconnect the unit from the gas supply.
2. Remove any attached restraining devices and relocate the fryer for service accessibility.
3. After servicing is complete, reconnect the unit to the gas supply, reattach restraining devices, and plug in the electrical cords.

## 1.6 Cleaning the Gas Valve Vent Tube

1. Set the fryer power switch and the gas valve to the OFF position.
2. Carefully unscrew the vent tube from the gas valve. **NOTE:** The vent tube may be straightened for ease of removal.
3. Pass a piece of ordinary binding wire (.052 inch diameter) through the tube to remove any obstruction.
4. Remove the wire and blow through the tube to ensure it is clear.
5. Reinstall the tube and bend it so that the opening is pointing downward.

## 1.7 Checking the Burner Manifold Gas Pressure

1. **On non-CE fryers only** ensure that the gas valve knob is in the OFF position.

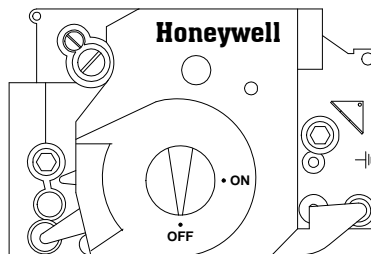

2. Remove the pressure tap plug from the gas valve assembly.

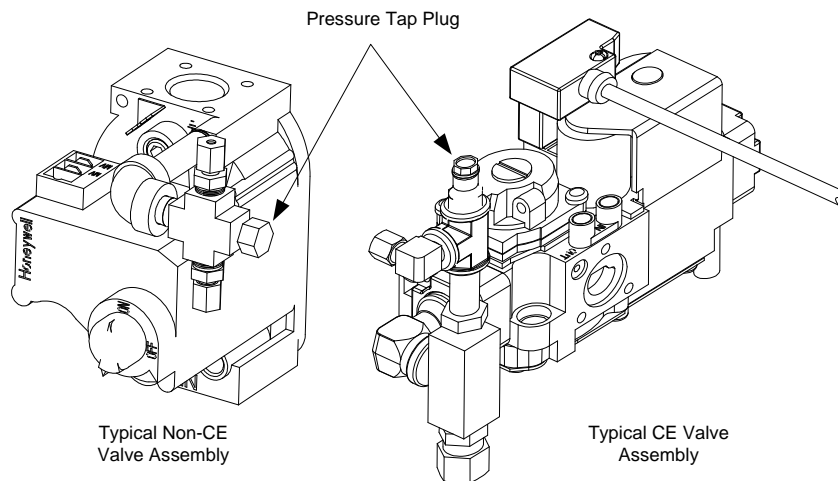

3. Insert the fitting for a gas pressure-measuring device into the pressure tap hole.
4. **On non-CE fryers only**, place the gas valve in the ON position.
5. Place the fryer power switch in the ON position. When the burner has lit and burned steadily for at least one minute, compare the gas pressure reading to the pressure for the corresponding gas in the appropriate table on the following page. The tables list the burner manifold gas pressures for each of the gas types that can be used with this equipment.

CE Standard Burner Manifold Gas Pressures	
Gas	Pressure (mbar)
	Single Vat
Natural Gas Lacq (G20) under 20 mbar	7
Natural Gas Gronique * (G25) under 25 mbar	10
Natural Gas Gronique (G25) under 20 mbar	10
Butane/Propane (G30) at 28/30 or 50 mbar	17
Propane (G31) under 37 or 50 mbar	20

\* Belgian G25 = 7,0 mbar

Non-CE Standard Burner Manifold Gas Pressures	
Gas	Pressure
Natural	3" W.C. 0.73 kPa
Propane	8.25" W.C. 2.5 kPa

6. To adjust the burner gas pressure, remove the cap from the gas valve regulator and adjust to the correct pressure.

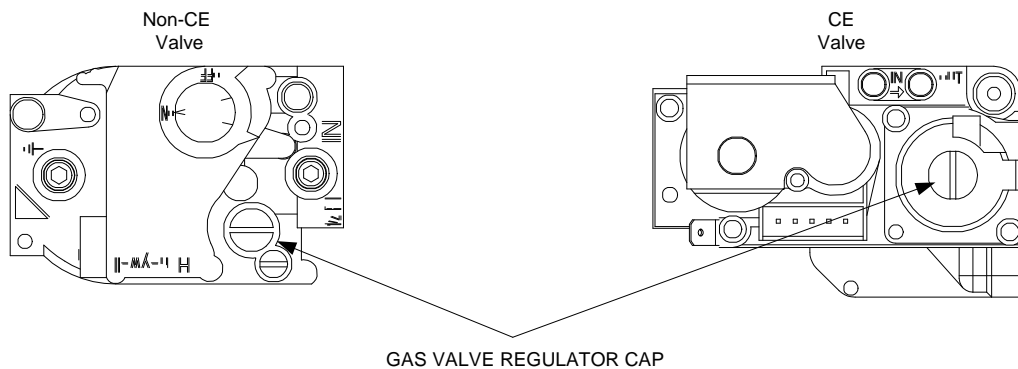

7. Place the fryer power switch (and the gas valve in non-CE fryers) in the OFF position. Remove the fitting from the pressure tap hole and reinstall the pressure tap plug.

## 1.8 Measuring Flame Current

When the burner flame is properly adjusted, it will produce a current between 2.5  $\mu\text{A}$  and 3.5  $\mu\text{A}$ . Flame current is measured by placing a *microamp* (not milliamp) meter in series with the sensing wire on the ignitor. This is accomplished as follows:

1. Place the fryer power switch in the OFF position.

2. Disconnect the sensing wire from one of the burner ignitors and connect it to the positive lead of the meter. Connect the negative lead of the meter to the terminal from which the sensing wire was removed.

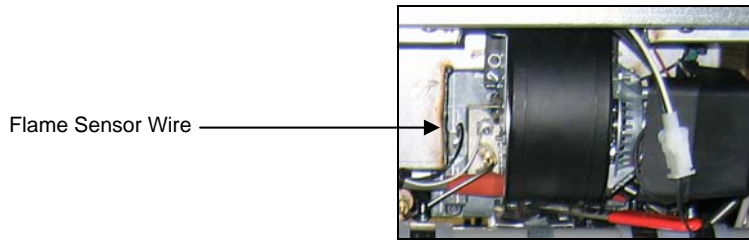

3. Place the fryer power switch in the ON position to light the burners. After the frypot temperature reaches 200°F (93°C), wait at least one minute before checking the reading. **NOTE:** The closer the unit is to normal operating temperature, the more accurate the reading will be.

## 1.9 Replacing Fryer Components

### 1.9.1 Replacing the Controller or the Controller Wiring Harnesses

1. Disconnect the fryer from the electrical power supply.
2. Open the control panel by removing the screws on the bottom of the bezel. Carefully lower the bezel.
3. Remove the two screws from the upper corners of the controller. The controller is hinged at the bottom and will swing open from the top.
4. Unplug the wiring harnesses from the connectors on the back of the controller marking their position for reassembly and disconnect the grounding wires from the terminals. Remove the controller by lifting it from the hinged slots in the control panel frame.

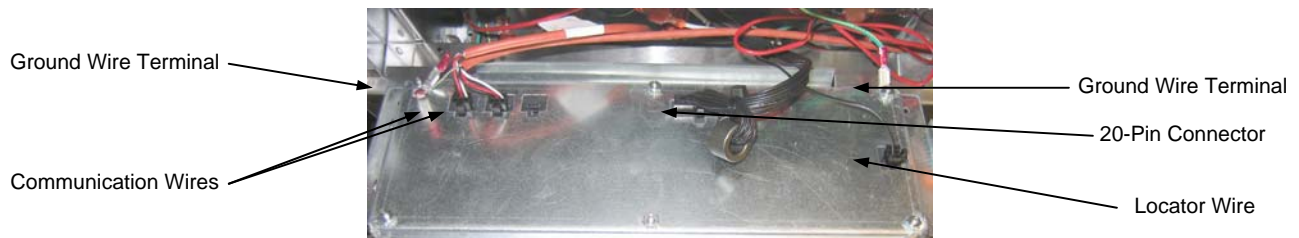

3000 controller illustrated. CM3.5 not illustrated.

5. Install the replacement controller. Reverse steps 1 thru 4.
6. Setup the 3000 controller following the instructions on page 4-3 in the Installation and Operation manual. Setup **MUST** be performed after replacement. See Frymaster Controller Manual 819-5871 for CM3.5 setup.
7. Once setup is complete on all replaced controllers, reset all control power following the instructions in section 1.13.6 on page 1-33 to readdress the new 3000 controller. Check software version and if necessary update the software. If a software update was necessary, follow the instructions to update the software in section 1.15 on page 1-40.

### 1.9.2 Replacing the Temperature Probe, ATO Probe or High-Limit Thermostat

1. Disconnect the fryer from the electrical supply.
2. Drain cooking oil below the level of the probe or thermostat.
3. Remove the screws on the bottom of the bezel. Carefully lower the bezel.
4. Remove the top two screws in the upper corners of the controller.
5. Swing the controller out from the top and allow it to rest on its hinge tabs.
6. Disconnect the controller wiring harness(es) and ground wire from the back of the controller and remove the controller by lifting it from the hinge slots in the control panel frame.
7. Disconnect the ignition cables from the ignitors by grasping the boots and gently pulling toward you.
8. Disconnect the flame sensor wires from the flame sensors.
9. Disconnect the sound device lead from the interface board.

10. If working on the left frypot, cut the wire tie on the wiring bundle and disconnect the main wiring harness 15-pin connector.
11. Remove the component box mounting screws.
12. Rotate the top of the component box out of the frame and carefully pull it out enough to disconnect the wiring harness plug from the back of the box. This will leave one set of wires, enclosed in spiral wrap, connected to the component box.
13. Remove the box and set it atop the fryer to expose the temperature probe and high-limit thermostat.
14. Unscrew the probe or thermostat from the frypot.
15. Apply Loctite® PST56765 pipe thread sealant or equivalent to the replacement part threads and screw the replacement part into the frypot, torquing to 180 inch-pounds.
16. If replacing the ATO probe, disconnect the harness from the ATO board or extension harness. Ensure when replacing the new probe that it does not extend past the wall of the frypot before tightening the ferrule.
17. Connect the wires from the new component as follows:
  - a. If replacing the temperature probe, use a pin pusher to disconnect (one at a time) the red and white leads from the connector and insert the corresponding leads from the new probe into the plug..
  - b. If replacing the high-limit thermostat, use a pin pusher to disconnect the lead running to the connector and insert the corresponding lead from the new thermostat.
  - c. Disconnect the other lead from the drain safety switch and connect the remaining lead from the new thermostat.
18. Reverse steps 1 through 13 to complete the procedure.

### 1.9.3 Replacing the Interface Board

1. Perform steps 1 through 4 from section 1.9.1.
2. Disconnect the wires attached to the interface board, marking or making a note of the wires and terminals to facilitate reconnection.
3. Remove the nuts at each corner of the interface board and carefully pull it from the studs far enough to allow the connector on the back of the board to be disconnected, then remove the board from the box. When removing the board, be careful not to lose the spacers that fit over the studs behind the board.
4. Recover the relay(s) from the failed interface board and install on the replacement board.
5. Reverse the procedure to install the replacement board, being sure that the spacers behind the board are in place and the computer locator ground wire is attached to a stud.

### 1.9.4 Replacing an Ignition Module

1. Disconnect the fryer from the electrical supply.
2. Remove the screws on the bottom of the bezel. Carefully lower the bezel.
3. Remove the top two screws in the upper corners of the controller.
4. Swing the controller out from the top and allow it to rest on its hinge tabs.
5. Loosen the nuts attached to the screws of the module. Slide the module towards the rear of the component box until the nuts drop through the keyholes.
6. Carefully rotate the module and pull forward. On some units it may be necessary to remove the blower.
7. Disconnect the wires from the ignition module, marking or making a note of the wires and terminals to facilitate reconnection.
8. Remove the screws from the module.
9. Move the screws and spacers to the new module.
10. Reverse the procedure to install the replacement module.

### 1.9.5 Replacing an Ignitor Assembly



**Drain the frypot or remove the handle from the drain valve before proceeding further.**

1. Disconnect the fryer from the electrical supply.

2. Disconnect the flame sensor wire by carefully pulling its push-on terminal from the terminal strip on the ignitor. Disconnect the gas enrichment tube at the ignitor-end compression fitting. Disconnect the ignition cable from the ignitor by grasping its boot and gently pulling toward you. (See photo below)

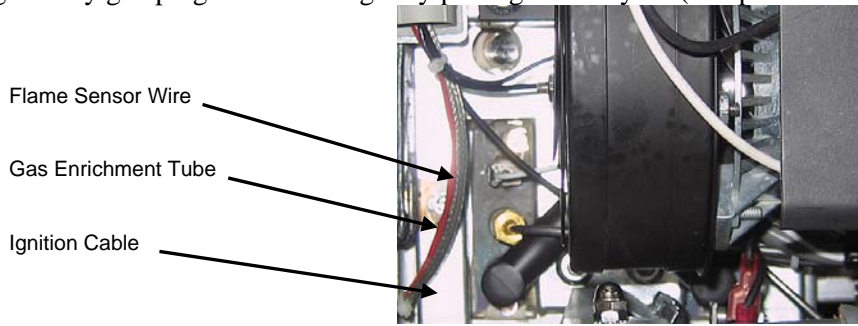

3. Remove the sheet metal screws securing the ignitor to the mounting plate and pull the ignitor from the fryer.
4. Reverse the procedure to install the replacement ignitor.

### 1.9.6 Replacing or Cleaning a Combustion Air Blower

1. Disconnect the blower wiring harness, remove the blower assembly mounting nuts, and remove the blower assembly from the fryer. If cleaning the motor, continue with Step 2; otherwise, install the replacement blower, reconnect the wiring harness, and then go to Step 6.

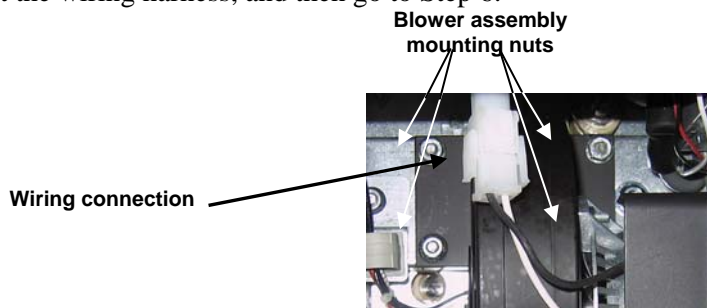

2. Remove the blower motor shield and separate the blower motor from the housing as shown in the illustration below.

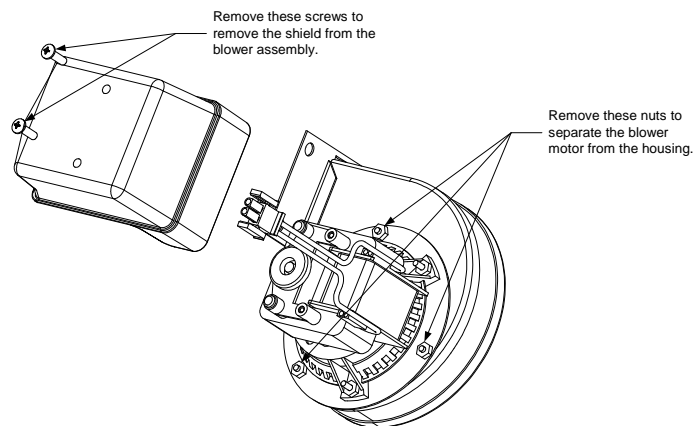

3. Wrap the motor with plastic wrap to prevent water from entering it. Spray degreaser or detergent on the blower wheel and the blower housing. Allow it to soak for five minutes. Rinse the wheel and housing with hot tap water, then dry with a clean cloth.

**NOTICE- Australia Only**  
**The air pressure switch on the combustion blower should read: Full Vat units-122pa (0.5 inches W.C.) and for Split Vat units-180pa (0.72 inches W.C.).**

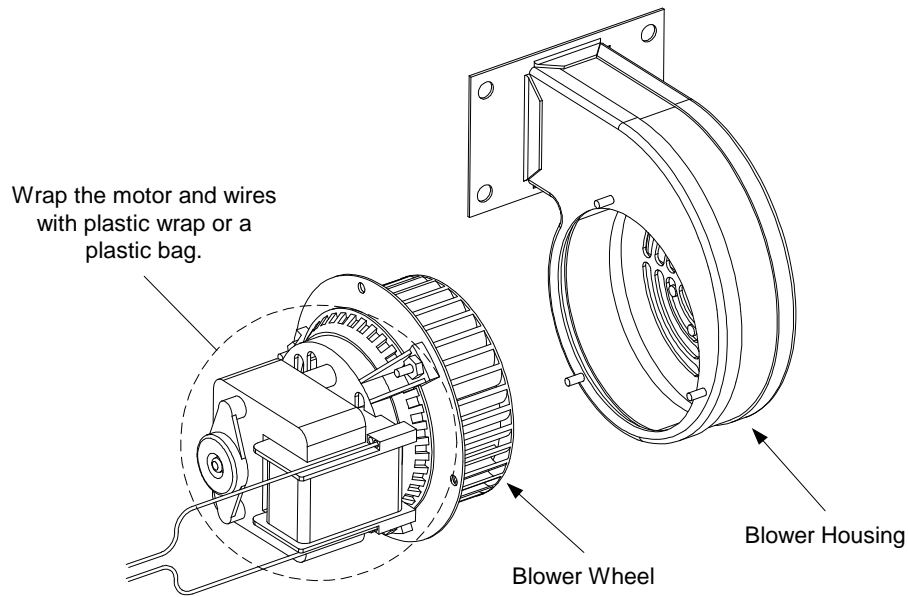

4. Remove the plastic wrap from the blower motor assembly. Reassemble the blower motor assembly and blower housing. Reinstall the blower shield.
5. Reinstall the blower assembly in the fryer and reconnect the wiring disconnected in Step 1.
6. Light the fryer in accordance with the procedure described in Chapter 3, Section 3.2.2 of the OCF30™ Series Gas Fryer Installation and Operation Manual (P/N 819-6687).
7. After the burners have been lit for at least 90 seconds, observe the flames through the burner viewing ports located on each side of the combustion air blower.

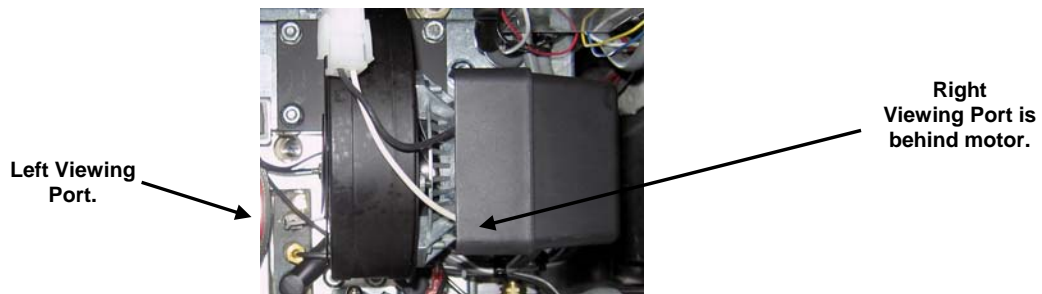

The air/gas mixture is properly adjusted when the burner manifold pressure is in accordance with the applicable table on page 1-6 and the burners display a bright orange-red glow. If a blue flame is observed or if there are dark spots on a burner face, the air/gas mixture requires adjustment. **NOTE: Opening the air shutter too much may result in whistling. It should not be more than 1/3 open.**

### 1.9.7 Adjusting the Air/Gas Mixture

On the side of the blower housing opposite the motor is a shutter plate with a locking nut. Loosen the nut enough to allow the shutter to be moved, then adjust the position of the shutter to open or close the air intake opening until a bright orange-red glow is obtained. Carefully hold the shutter in position and tighten the locking nut (see illustration on the following page).



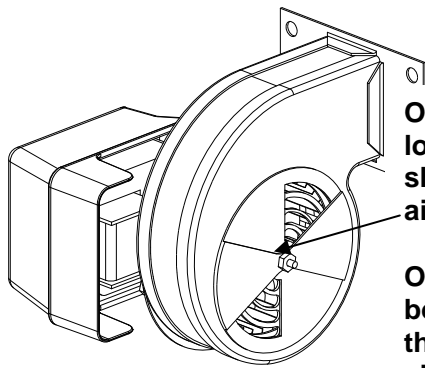

On non-CE blowers loosen this nut and rotate shutter to open or close air intake.

On CE blowers loosen both wing nuts and slide the shutter to adjust the air intake.

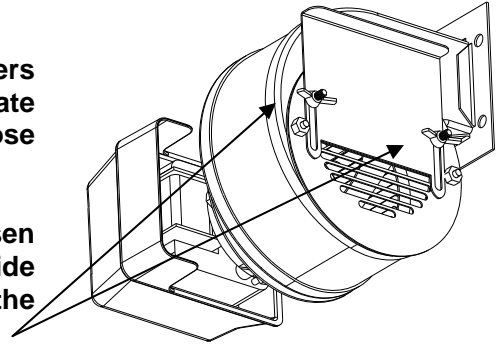

### 1.9.8 Replacing a Gas Valve

1. Disconnect fryer from electrical and gas supplies.
2. Disconnect the drain safety and high-limit thermostat wires from the gas valve. Mark each wire to facilitate reconnection.
3. Remove the vent tube (on non-CE fryers) and the enrichment tube fitting from the valve. Disconnect the flexible gas line(s).

**If replacing the left-most valve on any configuration, or the right valve on a two-fryer battery, follow the instructions below. If replacing valves in other positions, skip to “ALL OTHER VALVES.”**

- A. Remove the filter pan from the unit. Remove the door adjacent to the valve being replaced.
- B. Remove the screws that attach the pan rails adjacent to the valve being replaced.
- C. Uncouple the pipe union and remove the gas valve and associated piping from the unit.
- D. Remove the fittings and associated piping from the failed valve and install them on the replacement valve using Loctite® PST56765 or equivalent pipe thread sealant.
- E. Reconnect the gas valve assembly to the fryer using Loctite® PST56765 or equivalent pipe thread sealant, and reattach the flexible gas line(s), enrichment tube(s), and the vent tube (on non-CE units). Reconnect the high-limit thermostat wires and drain safety wires to the valve.
- F. Reconnect the fryer to the gas supply and open the cut off valve. Apply a thick soapy solution of water around each connection to check for gas leaks and ensure there are no bubbles. Eliminate any that are found. There should be no smell of gas.
- G. Position the pan rail assembly beneath the fryer and rest the rear end of the rail on the cabinet frame. Install the two nuts and bolts behind the front face of the rail, but do not tighten them. Install the nut and bolt at the rear end of the filter rail and tighten securely.
- H. Reattach the screws for the pan rails. Install the filter pan in the unit to make sure that all components are properly aligned.
- I. Reconnect the fryer to the electrical power supply and check for proper operation. When proper operation has been verified, reinstall the door removed in Step A.

### ALL OTHER VALVES

4. Carefully unscrew the valve from the manifold. **NOTE:** Some models may have the valve attached to the manifold by means of a pipe union. In such cases, remove the valve by uncoupling the union.
5. Remove all fittings from the old gas valve and install them on the replacement valve, using Loctite® PST56765 or equivalent pipe thread sealant.
6. Reconnect the gas valve assembly to the fryer using Loctite® PST56765 or equivalent pipe thread sealant, and reattach the flexible gas line(s), enrichment tube(s), and the vent tube (on non-CE units). Reconnect the high-limit thermostat wires and drain safety wires to the valve.
7. Reconnect the fryer to the gas supply and open the cut off valve. Apply a thick soapy solution of water around each connection to check for gas leaks and ensure there are no bubbles. Eliminate any that are found. There should be no smell of gas.
8. Reconnect the fryer to the electrical power supply and check for proper operation.

## 1.9.9 Replacing a Burner Assembly

1. Disconnect the unit from the electrical and gas supplies.
2. Remove the gas line and enrichment tube using a 7/16" and 5/8" wrench from the front of the burner.
3. Remove the elbow and tee off the bottom of the burner to ensure easier removal of the burner.
4. Remove the fryer back.
5. Remove the screws attaching the flue cap to the brace.
6. Remove the top cross brace in the back.
7. Remove the flue by removing the two screws in the rear and one screw in the front of the flue.



Figure 1

8. Remove all the screws on the flue collector and bend back the tabs and remove the collector.
9. Remove four screws on the collector insulation plate (see Figure 1).
10. Remove the four nuts and cover of the lower insulation retaining cover (see Figure 2).
11. Carefully remove the insulation.
12. Grasp the burner firmly and slide the burner out the rear of the fryer. Pull it toward you until it clears the burner channels, taking care not to damage the ceramic tiles in the process.

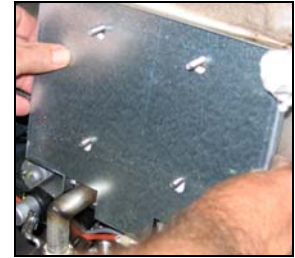

Figure 2

13. Slide the burner out the rear of the fryer.
14. Clean all debris from the burner channels and combustion area.
15. Inspect the upper and lower burner rails for cracked or burned out welds.
  - a. If the welds in the lower rail are cracked or burned out, the frypot must be replaced. Refer to Section 1.9.11 for procedure.
  - b. If the welds in the upper rail are cracked or burned out, the upper rail must be replaced. Refer to Section 1.9.12 for procedure.



Figure 3

16. Wrap a new insulating strip along the top, rear, and bottom edge of the burner.  
**NOTE:** Use P/N 826-0931 for full-vat frypots and P/N 826-0932 for dual-vat frypots.
17. Carefully slide the replacement burner into the rails starting at the top and lifting slightly up on the bottom (see Figure 3). Ensure that the insulation is not torn or damaged.
18. In reverse order, reassemble insulation and holding plates.
19. Install flue collector.
20. Install the flue.
21. Install the cross brace, ensuring the flue cap is secured to the brace.
22. Replace the fryer back.
23. Reattach the elbow, gas line and enrichment tubes to the front of the burner.
24. Fill the frypot with oil. Turn the fryer on; turn off or bypass the melt cycle and operate the unit for at least 10 minutes.
25. Examine the burner flame. The color and intensity on both sides should be the same.
26. Use an inspection mirror to check for leaks in areas that cannot be directly observed.
27. If a leak is detected, tighten all the lower insulation retainer nuts, allow the frypot to heat for five additional minutes, and repeat steps 25 and 26.
28. If a leak persists, use a rubber hammer and a small block of wood to tap the corners of the lower combustion chamber insulation retainers. Repeat steps 25 through 27. **Repeat this step until no leakage is detected.**

### 1.9.10 Replacing the Filter Motor, Filter Pump, or Filter Pump Solenoid Valve

1. Disconnect the unit from the electrical power supply.
2. Remove the filter pan from the unit.
3. Position a container beneath the oil return fitting at the front of the cabinet. Disconnect the flexible oil lines from the fittings, allowing any residual oil to drain into the container.
4. At the rear of the fryer, unplug the left connector (as viewed from the rear of the fryer) from the transformer box.
5. Remove the four nuts and bolts attaching the motor mount to the rear motor mount support.
6. At the front of the fryer, remove the cover plate from the front of the motor and disconnect the motor wires.
7. Place a 1-foot (30.5-cm) length of wood (or similar support) beneath the motor mount near the front of the unit and remove the two remaining nuts and bolts attaching the motor mount to the front cabinet cross-brace.
8. Carefully remove the support and lower the motor mount to the floor, allowing the rear of the mount to slide forward and off the rear motor mount support.
9. Disconnect the return flexline from the pump. The motor and pump assembly can now be pulled from beneath the fryer and the failed component can be removed and replaced.
10. Position the replacement motor and pump assembly beneath the fryer and reconnect the oil return flexline to the pump. Lift the rear of the motor mount up and onto the rear motor mount support.
11. Lift the front of the motor mount up and support it with a 1-foot (30.5-cm) piece of wood or a similar support. Install but do not tighten the two nuts and bolts that attach the motor mount to the front cabinet cross-brace.
12. Install and tighten the four nuts and bolts that secure the motor mount to the rear motor mount support.
13. At the front of the fryer, tighten the two nuts and bolts at the front of the motor mount. Reconnect the motor power wires and reinstall the wiring cover plate.
14. Reconnect the oil return flexline and reinstall the filter pan.
15. Reconnect the unit to the electrical power supply, fill the frypots with oil and check for proper operation.

### 1.9.11 Replacing the Frypot

1. Disconnect the fryer from the electrical and gas supplies.
2. Remove the filter pan from the unit and drain one frypot at a time into a Shortening Disposal Unit (SDU) or other appropriate metal container.



**DO NOT attempt to drain more than one full frypot into the SDU at one time.**

3. Open the control panel by removing the two screws on the bottom of the bezel. Carefully lower the bezel.
4. Remove the top screws in the upper corners of the controller.
5. Grasp the upper edge of each controller and swing the controller downward. Unplug the controller wiring harness and grounding wire from the back of each controller.
6. Remove the controllers by lifting them from the hinge slots in the control panel frame.
7. Disconnect the sound device wire from the interface board.
8. Disconnect the flame sensor wires by carefully pulling the push-on terminals from the terminal strips on the ignitors. Disconnect the gas enrichment tube at the ignitor-end compression fitting. Disconnect the ignition cables from the ignitors by grasping the boots and gently pulling toward you.
9. Dismount the topcap by removing the screws on the bottom of each front corner and lifting the topcap straight up.
10. Remove the two mounting screws on each side of the component box and rotate the top of the box out of the frame. Carefully pull it out enough to disconnect the wiring harness connector from the back of the box. Cut any ties that prevent the box from being pulled out of the control panel frame.
11. Carefully pull the box clear of the frame and rest it on top of the fryer.
12. Using a pin pusher, remove the temperature probe, high-limit thermostat wires and RTD probe wires from the plugs or terminals, marking each wire to facilitate re-assembly.
13. Remove the cover from the safety drain switch. Disconnect the wires from the switch.
14. Disconnect any auto top-off sensors if equipped and wiring.
15. Remove the section(s) of drain from the drain valve(s) of the frypot to be removed.

16. Disconnect the gas lines from the burner orifices and ignitor assemblies.
17. Remove the frypot hold down bracket.
18. Remove the screws in the back panel and inside the flue cap at each end that secure the flue cap to the fryer and lift it clear of the fryer.
19. Disconnect the oil return line(s) from the frypot to be removed.
20. Carefully lift the frypot from the fryer cabinet.
21. Remove the drain valve(s), temperature probe(s), high-limit thermostat(s), RTD probes, auto top-off sensors if equipped and ignitor assemblies. Inspect each of these components carefully and install them in the replacement frypot if they are in serviceable condition. Use Loctite® PST56765 sealant or equivalent on component threads.  
**NOTE:** Some servicers, based upon their experience, recommend that probes and thermostats be replaced whenever a frypot is replaced; however, this remains the customer's decision.
20. Reverse steps 1-19 to reassemble fryer.  
**NOTE:** Care should be taken not to over-torque nuts on frypots made of 400-series stainless steel, as this could tear the material. One turn past hand-tight is sufficient torque.
21. Perform steps 14 through 18 of Section 1.9.9 to ensure that there are no leaks in the burner insulation.

 **CAUTION**

**Before installing temperature probe, high-limit thermostat, RTD probe and drain valve on replacement frypot, clean the threads and apply Loctite® PST56765 thread sealant or equivalent.**

### 1.9.12 Replacing Frypot Insulation and/or Upper Burner Rails

**NOTE:** Replacing the burner rails requires completely tearing down the frypot and installing new frypot insulation. Refer to the frypot exploded view below for component identification.

1. Remove the frypot per Section 1.9.11.
2. Remove the burner assemblies (1).
3. Remove insulation retainers and blanket insulation (2).
4. Remove the upper oil zone insulation bracket and upper oil zone insulation (3).
5. Remove the plenum (4).
6. Remove the front lower combustion chamber insulation retainer and insulation (5) and the front lower combustion chamber inner insulation retainer and insulation (6). **NOTE:** Full-vat units have two-piece insulation retainer and insulation components. Dual-vat units have one-piece components.
7. Remove the upper combustion chamber insulation retainer and insulation (7).
8. Remove the inner upper combustion chamber insulation retainer and insulation (8).
9. Remove the rear lower combustion chamber retainers, back, and insulation (9). **NOTE:** Full-vat units have two-piece backs and four retainers. Dual-vat units have one-piece backs and two retainers.
10. Remove the flue assembly (10).

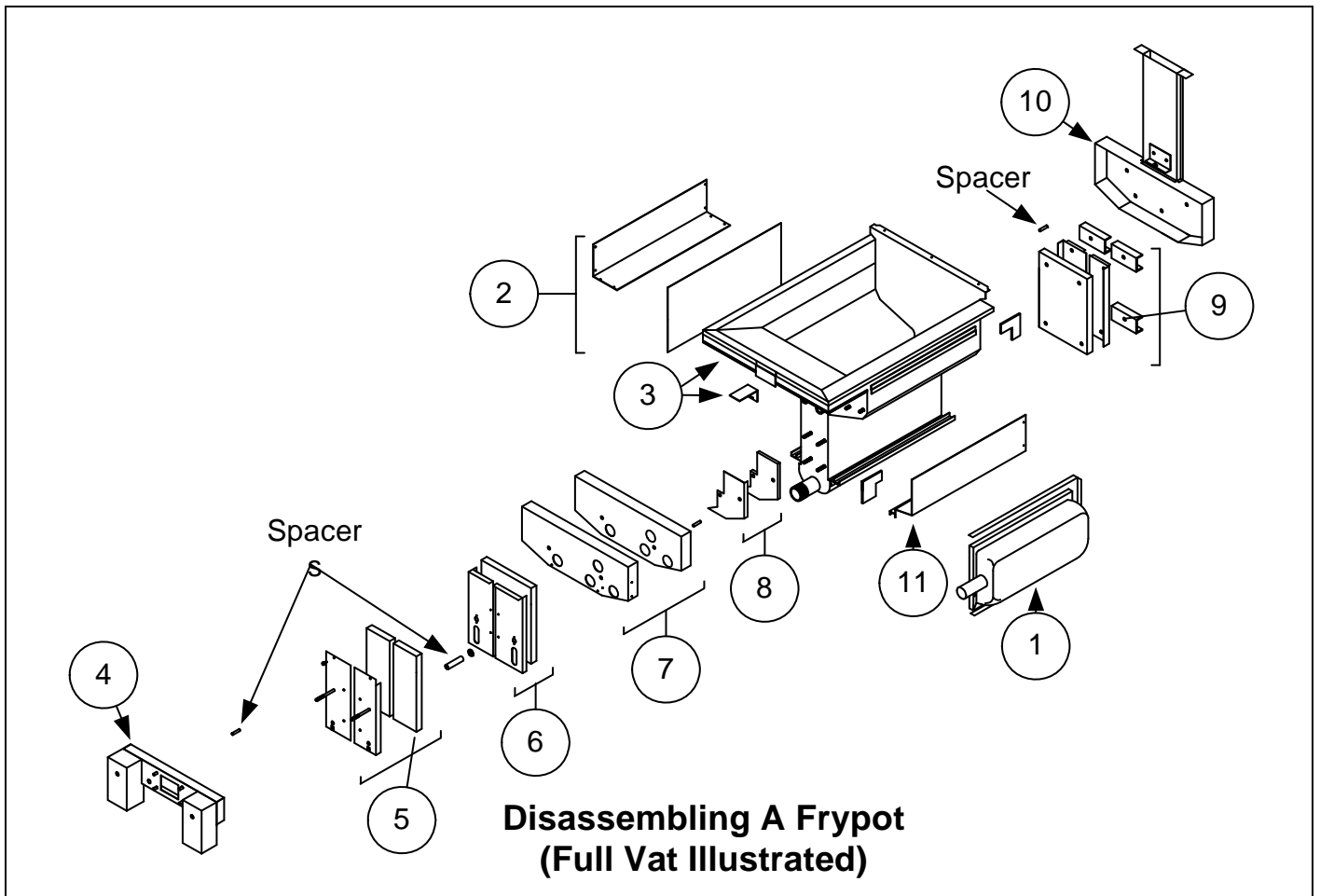

See page 1-17 for reassembly illustration.

11. Remove the upper burner rails (11). **NOTE:** For the following steps, refer to the frypot exploded view on page 1-16 for component identification.
12. Remove any residual insulation, sealant, and/or oil from the exterior of the frypot.
13. Place the “L” shaped pieces of the combustion chamber insulation (1) in the front and rear corners of both upper rail-retaining slots. (See page 1-17).
14. Using a mallet and short piece of wood, tap the corner tabs of the combustion chamber over the insulation to ensure a solid seal of the burner.
15. Install the upper burner rails (2) with the heat deflectors slanting toward the rear of the frypot. The rails will cover the “L” shaped pieces of combustion chamber insulation previously installed.
16. Place the upper inner combustion chamber insulation and insulation retainers (3) on the top two studs on each side of the front of the frypot and secure with ¼”-20 washer-nuts. *It is normal for the retainers to slice off the overhanging insulation.*
17. Place the lower rear combustion chamber insulation (4) on the lower four studs at the rear of the frypot.
18. Place one 1.625-inch tubular spacer (5) on each of the flue assembly (upper) studs at the rear of the frypot. **NOTE:** There are three different sizes of spacers. Verify the size to ensure the correct spacers are installed.
19. Press the flue assembly (6) over the burner rails. It may be necessary to use a rubber mallet or screwdriver to align the components. Use four ¼”-20 washer nuts to secure the flue assembly. **Do not tighten the retainer nuts at this point. They should be finger-tight only.** **NOTE:** The flue edge will cover one to two inches of the lower insulation.
20. Install the lower rear combustion chamber back(s) and retainer(s) (7) with the flanged edge(s) against the flue. Secure with ¼”-20 washer nuts. **NOTE:** Full-vat units have two-piece backs and four retainers. Dual-vat units come with one-piece backs and only two retainers.

21. Insert the burners (9) into the rails to ensure the rail spacing and alignments are correct. The burner should slide freely into and out of the rails. The upper rail can be bent slightly to increase or decrease tension on the burner and the edges of the slot can be closed or opened slightly to best fit the burner frame.
22. Carefully wrap a strip of burner insulation (8) tightly around the rear and sides of the burner frame (9), with the glass-tape side of the strip on the outside. **Do not use duct tape or adhesive to secure the strip to the burner frame.**
23. Align the burner to the burner rails while maintaining tension on the insulation strip. Insert the burner at a slight angle and begin pushing the burner slowly into the rails until it contacts the rear combustion chamber. The fit should be snug, but not excessively tight.
24. Verify that the burners are flush with the front edge of the burner rails. Remove the excess burner insulation by cutting with a knife or diagonal pliers. **Do not try to tear the insulation!**
25. Insert the upper front insulation (10) into its retainer (11), making sure that the holes in each piece are aligned with one another. Install the assembly with the insulation side toward the frypot and secure with ¼"-20 washer-nuts. **Do not over tighten.**
26. Place a washer on each of the four lower studs on the front of the frypot. Install the lower inner front insulation (12) with the rectangular openings toward the drain valve nipple. Install the lower inner front insulation retainer(s) (13). **NOTE:** Full-vat units have a two-piece insulation retainer. Dual-vat units have a one-piece retainer.
27. If necessary, replace the sight-glasses and insulation (14).
28. Place one washer and one 1.888-inch spacer (15) on each stud. **NOTE:** There are three different sizes of spacers. Verify the size to ensure the correct spacers are installed.
29. Insert the front lower insulation (16) into the front lower insulation retainer(s) (17) and install assembly on frypot. Secure with ¼"-20 washer-nuts. If frypot uses two retainers, connect them together with two ¼" self-tapping screws. **NOTE:** Full-vat units have a two-piece insulation retainer and two pieces of insulation. Dual-vat units have one-piece components.
30. Return to the rear of the frypot and fully tighten all washer-nuts.
31. Remove and replace the plenum gaskets (18).
32. Place a 0.938-inch spacer (19) on the plenum-mounting studs, and mount the plenum (20). Ensure the gaskets are clear of the burner tubes by pulling the plenum back slightly. Place a washer on each stud and secure plenum with ¼"-20 lock-nuts.
33. Install the upper oil-zone insulation (21) by pressing it under the upper combustion chamber metalwork. Secure the insulation with the bracket (22) and ¼" self-tapping screws.
34. Install the upper burner rail blanket insulation (23). Position any excess insulation toward the top of the frypot. Avoid overhang past the bottom of the upper burner rail. Overhang in this area will make future burner replacement more difficult.
35. Cover the insulation with the insulation retainer (24), and secure with ¼" self-tapping screws.
36. Reinstall probes, drain valves, high-limit thermostats, and other pipe fittings using Loctite® PST56765 sealant or equivalent on the threads.

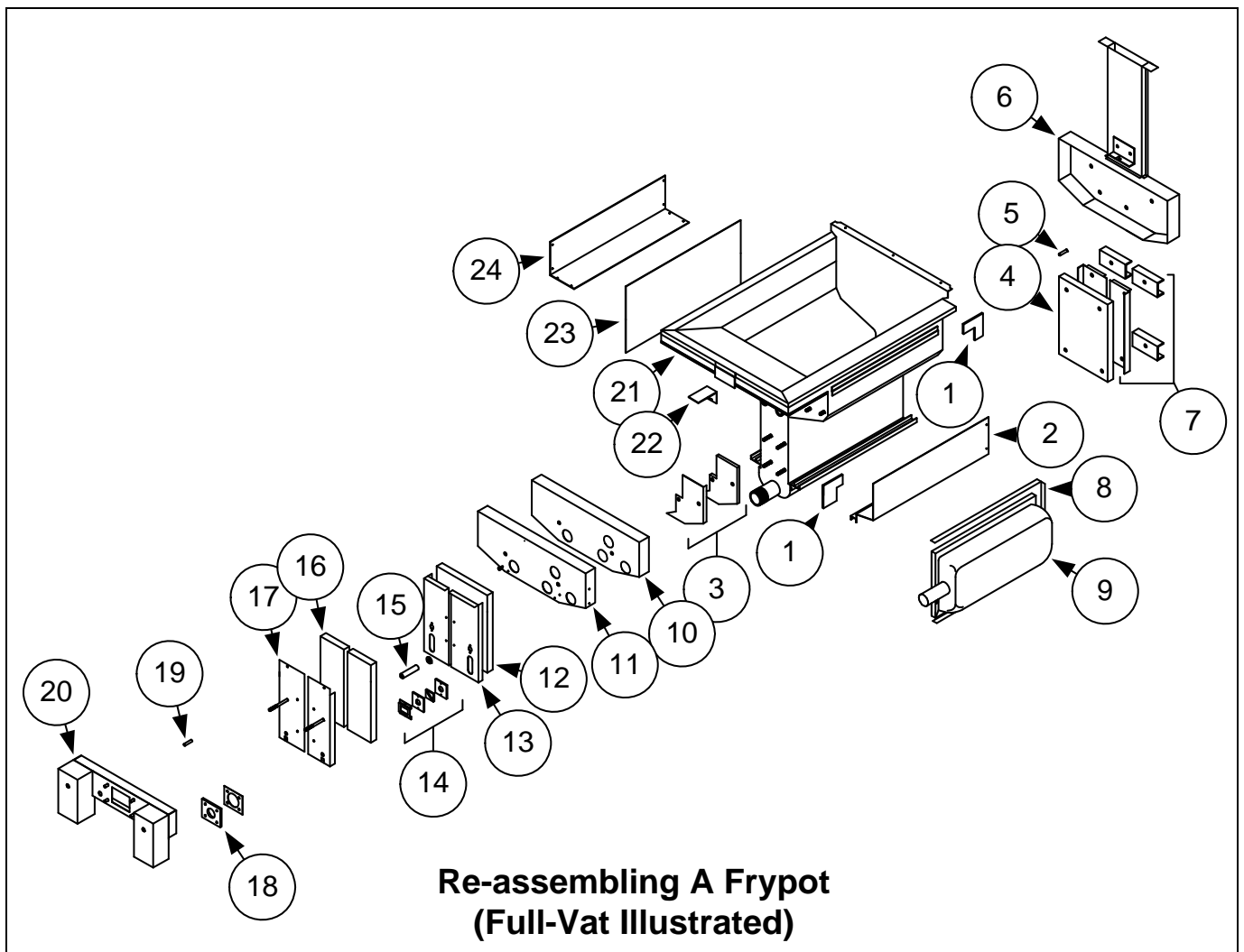

## 1.10 Troubleshooting and Problem Isolation

Because it is not feasible to attempt to include in this manual every conceivable problem or trouble condition that might be encountered, this section is intended to provide technicians with a general knowledge of the broad problem categories associated with this equipment, and the probable causes of each. With this knowledge, the technician should be able to isolate and correct any problem encountered.

Problems you are likely to encounter can be grouped into six categories:

1. Ignition failure
2. Improper burner function
3. Improper temperature control
4. Controller malfunctions
5. Filtration malfunctions
6. Leakage

The probable causes of each category are discussed in the following sections. A series of Troubleshooting Guides is also included at the end of the chapter to assist in solving some of the more common problems.

### 1.10.1 Heating (Ignition) Failure

Heating (ignition) failure occurs when the ignition module fails to sense a flame within the 4-second time delay period and locks out. When this happens, the module sends 24 VAC through the interface board alarm circuit to the controller.

3000 controllers display “**HEATING FAILURE.**”

The three primary reasons for ignition failure, listed in order of probability, are problems related to:

1. Gas and/or electrical power supplies
2. Electronic circuits
3. Gas valve.

#### PROBLEMS RELATED TO THE GAS AND/OR ELECTRICAL POWER SUPPLIES

The main indicators of this are that an entire battery of fryers fails to light and/or there are no indicator lights illuminated on the fryer experiencing ignition failure. Verify that the quick disconnect fitting is properly connected, the fryer is plugged in with connector twisted and locked, the main gas supply valve is open, and the circuit breaker for the fryer electrical supply is not tripped.

#### PROBLEMS RELATED TO THE ELECTRONIC CIRCUITS

If gas and electrical power are being supplied to the fryer, the next most likely cause of ignition failure is a problem in the 24 VAC circuit. Verify that the drain valve is fully closed. The valve is attached to a microswitch that must be closed for power to reach the gas valve (often, although the valve handle appears to be in the closed position, the microswitch is still open). If the valve is fully closed, refer to Section 1.11.1, **TROUBLESHOOTING THE 24 VAC CIRCUIT.**

Some typical causes of heating failure in this category include a defective sensing wire in the ignitor assembly, a defective module, a defective ignition wire, and a defective ignitor.

Occasionally, a heating failure occurs in which all components appear to be serviceable and the microamp reading is within specification, but the unit nevertheless goes into ignition failure. The probable cause in this case is an intermittent failure of an ignition module. When the unit is opened up for troubleshooting, the module cools down enough to operate correctly; however, when the unit is again closed up and placed back into service the module heats up and fails.

#### PROBLEMS RELATED TO THE GAS VALVE

If the problem is not in the 24 VAC circuit, it is most likely in the gas valve, itself. Before replacing the gas valve, refer to Section 1.11.2 **TROUBLESHOOTING THE GAS VALVE.**

### 1.10.2 Improper Burner Function

With problems in this category, the burner ignites but exhibits abnormal characteristics such as “popping,” dark spots on the burner ceramics, fluctuating flame intensity, and flames shooting out of the flue.

“**Popping**” indicates delayed ignition. In this condition, the main gas valve is opening but the burner is not immediately lighting. When ignition does take place, the excess gas “explodes” into flame, rather than smoothly igniting.

The primary causes of popping are:

- Incorrect or fluctuating gas pressure
- Defective or incorrectly adjusted combustion air blower
- Inadequate make-up air
- Heat-damaged computer or ignition module
- Cracked ignitor or broken ignition wire
- Defective ignition module
- Cracked burner tile (typically causes a very loud pop).



If popping occurs only during peak operating hours, the problem may be incorrect or fluctuating gas pressure. Verify that the incoming gas pressure (pressure to the gas valve) is in accordance with the appropriate CE or Non-CE Standard found in Section 2.3 page 2-4 of the OCF30™ Series Gas Fryer Installation and Operation Manual (PN 819-6687), and that the pressure remains constant throughout all hours of usage. Refer to Section 1.7, **Checking the Burner Manifold Gas Pressure** in this manual for the procedure for checking the pressure of gas supplied to the burner.

If popping is consistent during all hours of operation, the most likely cause is an insufficient air supply. Check for “negative pressure” conditions in the kitchen area. If air is flowing into the kitchen area, this indicates that more air is being exhausted than is being replenished and the burners may be starved for air.

If the fryer’s gas and air supplies are correct, the problem is most likely with one of the electrical components. Examine the ignition module and controller for signs of melting, distortion, and/or discoloration due to excessive heat build-up in the fryer (this condition usually indicates improper flue performance). A melted or distorted ignition module is automatically suspect and should be replaced; however, unless the condition causing excessive heat is corrected, the problem is likely to recur.

Verify that the ignition wire is tightly connected at both ends and free of obvious signs of damage. Again, if damage is due to excessive heat in the fryer, that problem must also be corrected. Check for proper operation by disconnecting the wire from the ignitor (spark plug), inserting the tip of a screw driver into the terminal. With the insulated handle of the screwdriver, hold the shaft near the frame of the fryer as the power switch is placed in the ON position. A strong, blue spark should be generated for at least four seconds.



**Make sure you are holding the insulated handle of the screwdriver and not the blade. The sparking charge is approximately 25,000 volts.**

Examine the ignitor (spark plug) for any signs of cracking. A cracked ignitor must be replaced.

If all other causes have been ruled out, examine the burner tiles for any signs of cracking. If cracking is found, the burner must be replaced.

**Fluctuating flame intensity** is normally caused by either improper or fluctuating incoming gas pressure, but may also be the result of variations in the kitchen atmosphere. Verify incoming gas pressure in the same way as for “popping,” discussed in the preceding paragraphs. Variations in the kitchen atmosphere are usually caused by air conditioning and/or ventilation units starting and stopping during the day. As they start and stop, the pressure in the kitchen may change from positive or neutral to negative, or vice versa. They may also cause changes in airflow patterns that may affect flame intensity.

**Dark spots on the burner tiles** are the result of an improper air/gas mixture. Adjust the combustion air blower to reduce the amount of air in the mixture to correct this problem

**Flames shooting out of the flue** are usually an indication of negative pressure in the kitchen. Air is being sucked out of the burner enclosure and the flames are literally following the air. If negative pressure is not the cause, check for high burner manifold gas pressure in accordance with the procedures in Section 1.7.

An **excessively noisy burner**, especially with **flames visible above the flue opening**, may indicate that the gas pressure is too high, or it may simply be that the gas valve vent tube is blocked. If the incoming gas pressure is correct and the vent tube is unobstructed, the gas valve regulator is probably defective.

Occasionally a burner may apparently be operating correctly, but nevertheless the fryer has a **slow recovery rate** (the length of time required for the fryer to increase the oil temperature from 250°F to 300°F (121°C to 149°C)). The primary causes of this include an over-filled frypot, a dirty or out-of-adjustment combustion air blower, low burner manifold pressure, and/or damaged burner tiles. Adding oil to the frypot during the recovery process will also cause a slow recovery rate.

If these causes are ruled out, the probable cause is a misadjusted gas valve regulator. Refer to Section 1.7, **Checking the Burner Manifold Gas Pressure**, for the gas valve adjustment procedure.

### 1.10.3 Improper Temperature Control

Temperature control, including the melt cycle, is a function of several interrelated components, each of which must operate correctly. The principle component is the temperature probe. Other components include the interface board, the controller itself, and the ignition module.

Improper temperature control problems can be categorized into melt cycle problems and failure to control at setpoint problems.

### MELT CYCLE PROBLEMS

Initiation of the melt cycle with 3000 controllers is automatic. Problems may originate from the controller itself, the temperature probe, or a malfunctioning heat relay on the interface board.

### FAILURE TO CONTROL AT SETPOINT

Problems in this category may be caused by the temperature probe, the interface board, or the controller.

### 1.10.4 Controller Malfunctions

#### RECOVERY TIME

*Recovery time* – is a method of measuring a fryer’s performance. Put simply, it is the time required for the fryer to increase the oil temperature from 250°F to 300°F (121°C to 149°C). This range is used as a standard since ambient kitchen temperatures can affect the test if lower ranges are used.

The 3000 controller performs the recovery test each time the fryer warms up. An operator can view the results of the test any time the fryer is above the 325°F (163°C) point by pressing the INFO button once when the fryer is on. The test results will be displayed in the controller’s LED panel in minutes and seconds. The maximum acceptable recovery time for OCF30™ series gas fryers is two minutes and twenty-five seconds (2:25).

### 1.10.5 Filtration Malfunctions

The majority of filtration problems arise from operator error. One of the most common errors is placing the filter pad on the bottom of the filter pan rather than over the filter screen.

Whenever the complaint is “the pump is running, but no oil is being filtered,” check the installation of the filter pad, including that the correct size is being used. While you are checking the filter paper/pad, verify that the O-rings on the filter pan suction tube are present and in good condition. Missing or worn O-rings will allow the pump to suck air and decrease its efficiency.

If the pump motor overheats, its thermal overload will trip and the motor will not start until it is reset. If the pump motor does not start, press the red reset switch located on the front of the motor. If the pump then starts, something caused the motor to overheat. It may be that several frypots in a large battery of fryers were being filtered one after the other and the pump became hot. Letting the pump cool down for at least a half-hour is all that is required in this case. More often, the pump overheated for one of the following reasons:

- Shortening that remained in the pan, after previous filtering, solidified in the suction tube recess in the bottom of the pan or the suction tube, itself. Adding hot oil to the pan and waiting a few minutes will usually correct this problem. A flexible wire can be used to clean out the suction tube and the recess in the bottom of the pan. **NEVER** use compressed air to blow solidified shortening out of the suction tube!

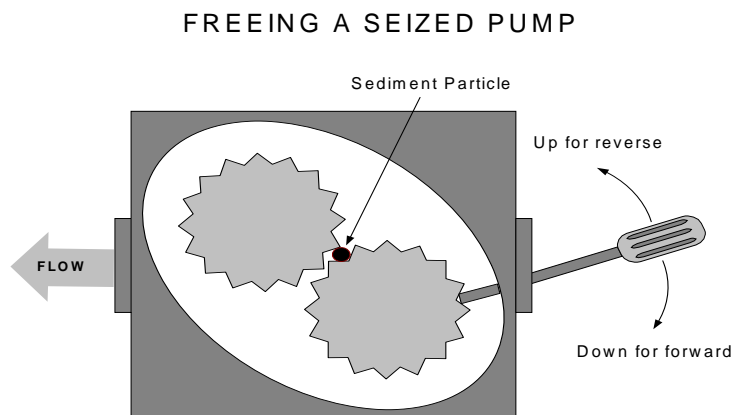

- The operator attempted to filter oil that was not heated. Cold oil is thicker and causes the pump motor to work harder and overheat.

If the motor hums but the pump does not rotate, there is a blockage in the pump. Incorrectly sized or installed paper will allow food particles and sediment to pass through the filter pan and into the pump. When sediment enters the pump, the gears can bind up and cause the motor to overload, tripping the thermal overload. Solidified shortening in the pump will also cause it to seize, with similar results.

A pump seized by debris or hard shortening can usually be freed by manually moving the gears with a screwdriver or other instrument as illustrated on the following page. **Make sure power to the pump motor is off before trying this.**

1. Disconnect power to the filter system.
  2. Remove the input plumbing from the pump.
  3. Use a screwdriver to manually turn the gears.
- Turning the pump gears backwards will release a hard particle and allow its removal.
  - Turning the pump gears forward will push softer objects and solid shortening through the pump and allow free movement of the gears.

Filter paper/pads that are installed incorrectly will also allow food particles and sediment to pass through and clog the suction tube recess on the bottom of the filter pan or the suction tube, itself. Particles large enough to block the suction tube recess or the suction tube may indicate that the crumb tray is not being used.

### 1.10.6 Leakage

Leakage of the frypot will usually be due to improperly sealed high-limit thermostats, RTD's, temperature probes, and drain fittings. When installed or replaced, each of these components must be sealed with Loctite® PST56765 sealant or equivalent to prevent leakage. In very rare cases, a leak may develop along one of the welded edges of the frypot. When this occurs, the frypot must be replaced.

If the sides or ends of the frypot are coated with oil, the most likely cause is spillage over the top of the frypot rather than leakage.

The clamps on the rubber boots that hold the drain tube sections together may loosen over time as the tubes expand and contract with heating and cooling during use. Also, the boot itself may be damaged. If the section of drain tube connected to the drain valve is removed for any reason, ensure that its rubber and clamps are in good condition and properly fitted around the drain tube when it is reinstalled. Also, check to ensure that the drain tube runs downward from the drain along its whole length and has no low points where oil may accumulate.

### 1.10.7 Basket Lift Malfunctions

OCF30™ series gas fryers may be optionally equipped with automatic basket lifts to ensure uniform cooking times. Basket lifts will always come in pairs, although each operates independently of the other. A modular basket lift consists of a toothed rod to which the basket lift arm is attached, a reversible-drive gear motor, and a pair of roller-activated microswitches. A gear on the motor shaft engages teeth in the rod. Depending upon the direction of motor rotation, the gear drives the rod up or down.

Timing circuitry in the controller initiates and stops operation of the basket lift depending upon the variables programmed by the operator. When a product button is pressed, the timing circuitry activates a coil to supply power to the motor, which lowers the basket into the frypot.

When the rod contacts and closes the lower microswitch, power to the motor is cut and the direction of current flow is reversed; this reverses the direction of motor rotation. When the programmed cooking time

has elapsed, power is again supplied to the motor. The motor raises the basket from the frypot until the rod loses contact with the upper microswitch, cutting power to the motor and again reversing the direction of current flow.

Problems with the basket lift can be grouped into three categories:

- Binds and jams
- Motors and gears
- Electronics.

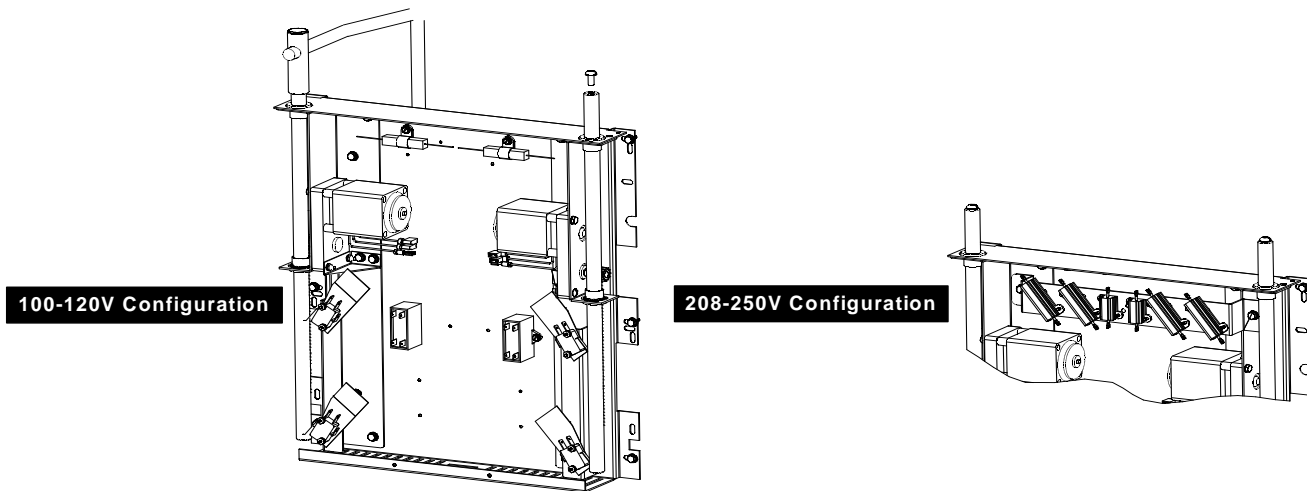

## Binding and Jamming Issues

Noisy, jerky or erratic movement of the lifts is usually due to lack of lubrication of the rods and bushings. Apply a light coat of Lubriplate<sup>®</sup> or similar lightweight white grease to the rod and bushings to correct the problem.

Another possible cause of binding is improper positioning of the motor, which prevents the gear from correctly engaging the teeth in the rod. To correct the problem, loosen the screws that hold the motor in place and move it forward or backward until the rod has just enough slack to be rotated slightly.

## Motor and Gear Issues

The most likely problem to be encountered in this category is erratic motion of the lift due to a worn drive gear. Failure to keep the lift rod and bushings properly lubricated will cause unnecessary wear of the gear. Correct the problem by replacing the worn gear.

If the lift cycles correctly but fails to remain in the up position (i.e., goes up, but then slowly settles back down into the frypot), the problem is a failed motor brake. This cannot be repaired and the motor must be replaced.

If power is reaching the motor but the motor fails to run, it is burned out and must be replaced.

## Electronic Issues

Within this category are problems associated with the relays, microswitches, capacitors, resistors, interface board, wiring, and controls. The most common problem in this category is a lift that continuously travels up and down. This is usually caused by a microswitch that is out of adjustment.

Troubleshooting the electronics of the basket lift is the process of verifying current flow through the individual components up to and including the motor. Using a multimeter set to the 250 VAC range, check the connections on both sides of the component for the presence of the applied line voltage. The wiring diagram on the pages 1-44 and 45 identifies the components and wiring connection points.

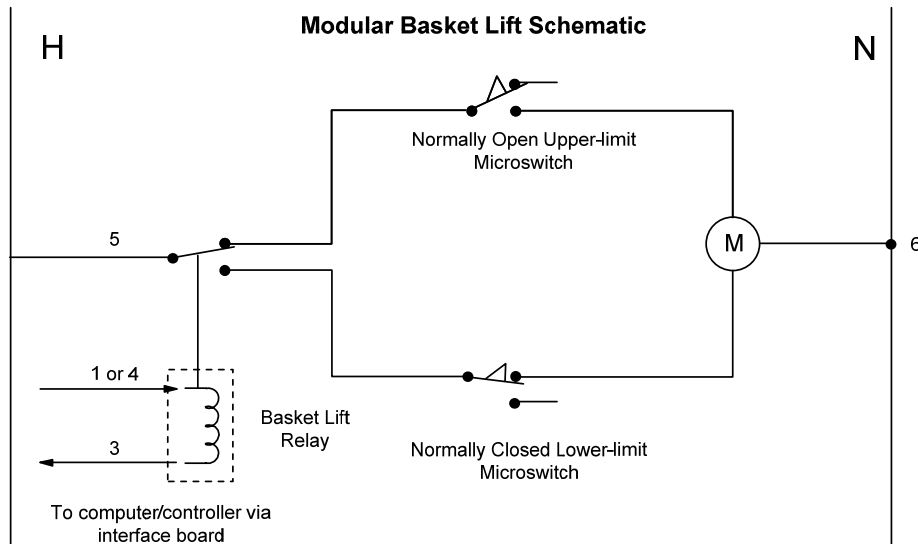

## 1.11 Troubleshooting Guides

The troubleshooting guides on the following pages are intended to assist service technicians in quickly isolating the probable causes of equipment malfunctions by following a logical, systematic process. An additional set of operator troubleshooting guides are contained in Chapter 7 of the OCF30 Series Installation and Operation Manual. It is suggested that service technicians thoroughly familiarize themselves with both sets.

### 1.11.1 Troubleshooting the 24 VAC Circuit

Prior to checking for problems associated with the 24 VAC circuit, ensure that the unit is connected to a power supply, the drain valve is fully closed, and the controller is on and is calling for heat (green dot appears under heat indicator and display toggles between **LOW TEMP**).

**NOTE:** All voltage measurements must be made within **4 seconds** of the unit calling for heat. If unit does not fire within **4 seconds**, ignition modules will lock out and controller must be turned off, then on to reset.

The following processes will assist you in troubleshooting the 24 VAC circuit and ruling it out as a probable cause:

- **24 VAC is not present on the interface board J3 pin 9 (LED 5 (GV)).**
  1. If LED 3 *is not* continually lit, the probable causes are a failed 24 VAC transformer or failed wiring between the transformer and interface board.
  2. If LED 3 *is* continually lit, check the right PWR terminal (LED 4) for 24 VAC. On dual units, also check the left PWR terminal (LED 2) for 24 VAC. Verify that the F2 fuse is not blown.
    - a. If 24 VAC *is not* present, the probable cause is a failed interface board, blown fuse or a defective heat relay.
    - b. If 24 VAC *is* present, check for 24 VAC on V1S (or V1D and V2D, if dual unit)..
      - i. If 24 VAC *is not* present, check the fuses. If they are good, the probable causes are failed ignition module(s) or a failed interface board. Replace the questionable ignition module with one known to be good to isolate the cause.

ii. If 24 VAC is present, the probable cause is a failed interface board.

- **24 VAC is present on interface board J3 pin 9 (LED 5 (GV)) and, on dual units, on J1 pin 9 (LED 1 (GV)).**

1. If 24 VAC is not present across the gas valve main coil (MV terminals), probable causes are an open high-limit thermostat or a failed wire between the interface board and gas valve. Be sure to check both valves on dual units.
  - a. Check continuity of high-limit thermostat and drain safety switch. If both are zero, problem is in wiring.
2. If 24 VAC is present across the gas valve main coil (MV terminals), the 24 VAC circuit is working and the problem may be with the gas valve. Be sure to check both valves on dual vat units.

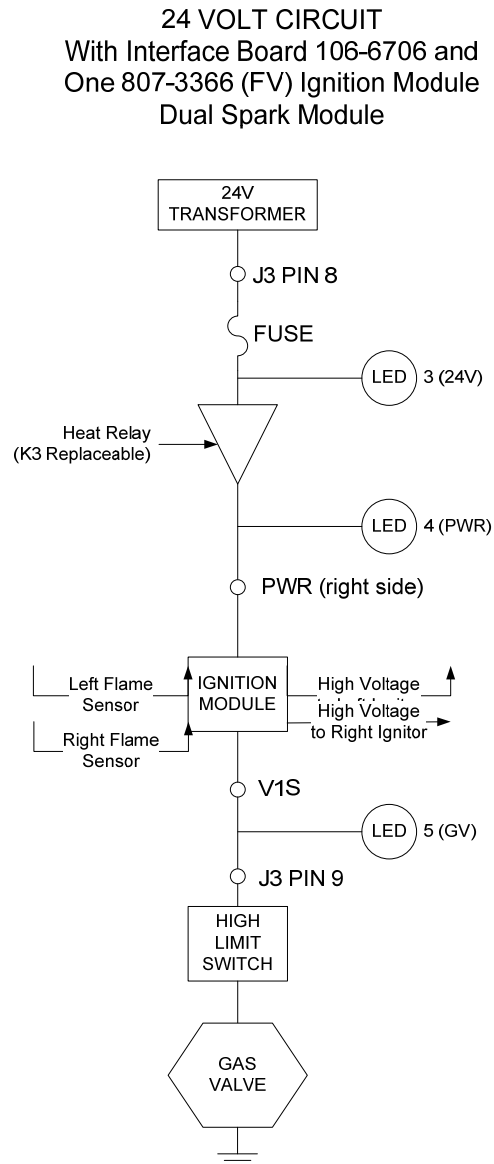
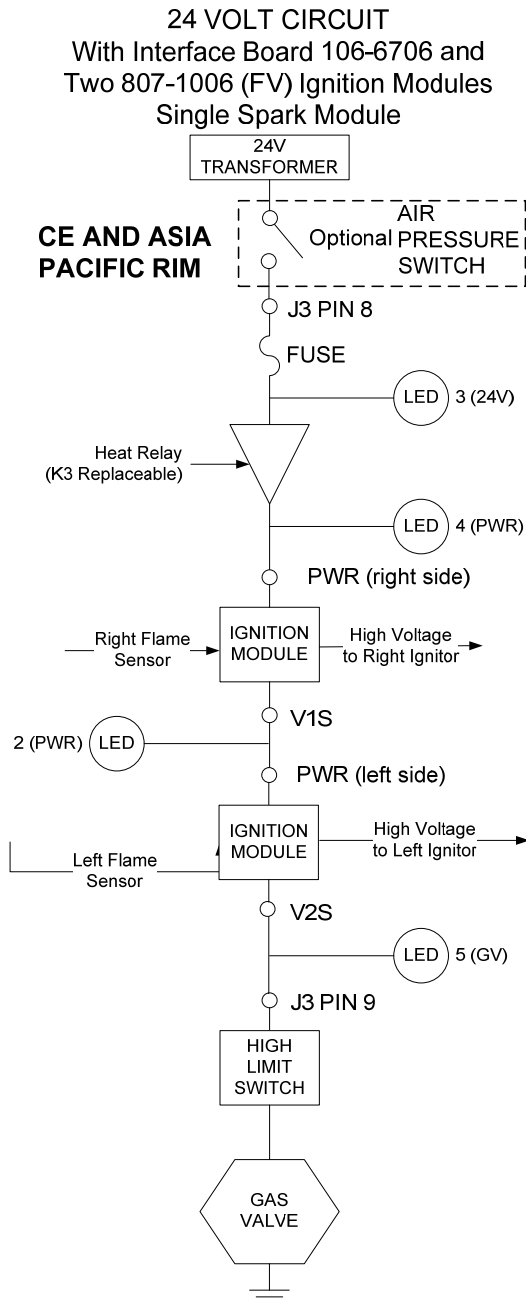

## 24 VOLT CIRCUIT With Interface Board 106-6706 and Two 807-3365 (DV) Ignition Modules

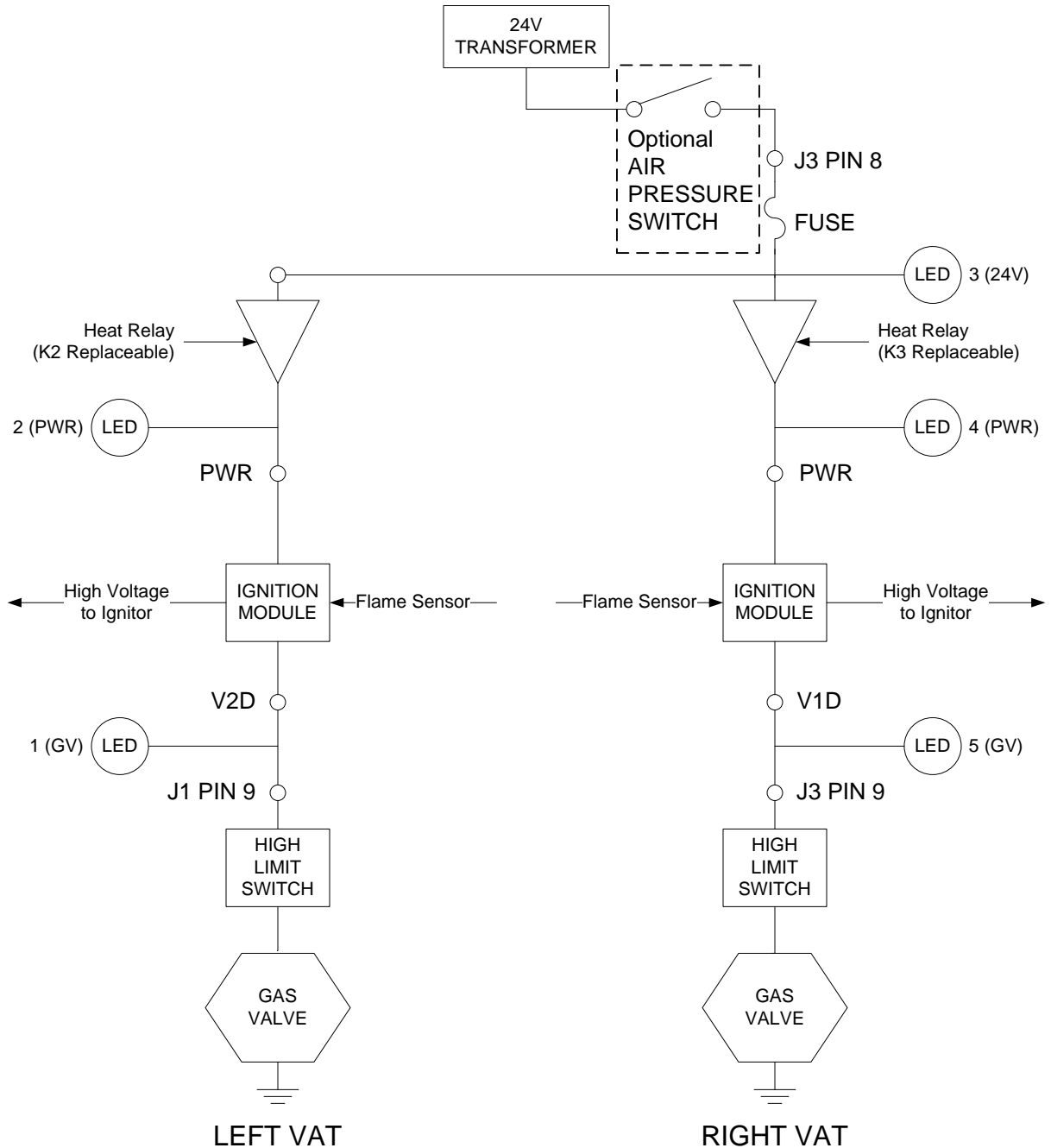

### 1.11.2 Troubleshooting the Gas Valve

Prior to checking for problems associated with the gas valve, ensure that the unit is calling for heat. Also, for non-CE units, verify that the gas valve is in the ON position.

The following processes will assist you in troubleshooting the gas valve and ruling it out as a probable cause:

- If 24 VAC is not present across gas valve main coil, the probable cause is the 24 VAC circuit. Refer to the 24 VAC circuit troubleshooting guide.

- If 24 VAC is present across gas valve main coil, check the incoming gas pressure and compare to the tables on page 2-4 of the Installation and Operation manual.
  1. If incoming gas pressure *is not* correct, the probable cause is a problem with the gas supply to fryer.
  2. If incoming gas pressure *is* correct, check the burner manifold gas pressure and compare it to the tables on page 2-7 of the Installation and Operation manual.
    - a. If burner manifold gas pressure *is not* correct, the probable cause is an improperly adjusted or failed gas valve. Adjust the valve by following the procedure “Check Burner Manifold Pressure” in Section 1.7 of this manual. If the valve cannot be adjusted, replace it.
    - b. If outgoing gas pressure *is* correct, the gas valve is okay.

### 1.11.3 Troubleshooting the Temperature Probe

**⚠ CAUTION**

**Disconnect the 3000 controller before testing temperature probe resistances to avoid invalid readings**

Prior to checking for problems associated with the temperature probe, inspect the probe body for damage while it is still in the frypot. Remove and replace the probe if it is bent, dented, or cracked. Also, inspect leads for fraying, burning, breaks, and/or kinks. If found, replace the probe.

The following processes will assist you in troubleshooting the temperature probe and ruling it out as a probable cause:

*Before testing the probe, determine the temperature of the cooking oil using another thermometer or pyrometer placed at the tip of the questionable probe.*

- **If resistance through J3 pins 2 and 6 (J1 pins 2 and 6 for left side of dual unit) is not approximately equal to that given in the Probe Resistance Chart for the corresponding temperature, the probe has failed and must be replaced.**
- **If resistance through J3 pins 2 and 6 (J1 pins 2 and 6 for left side of dual unit) is approximately equal to that given in the Probe Resistance Chart for the corresponding temperature, measure the resistance through each of the previously tested pins to ground.**
  1. If resistance *is not* 5 mega-Ohms or greater in each pin, the probe has failed and must be replaced.
  2. If resistance *is* 5 mega-Ohms or greater in each pin, the probe is okay.

### 1.11.4 Replacing the Transformer, Reset Switch or Filter Relay

Disconnect the fryer from the electrical power supply. Remove the cover from the transformer box in the rear of the fryer to expose the interior of the transformer box. Replace the transformer or filter relay marking the wires to ease reassembly. Once replaced, reconnect the power. When replacing a filter relay in the transformer, ensure the 24VAC relay (8070012) is used.

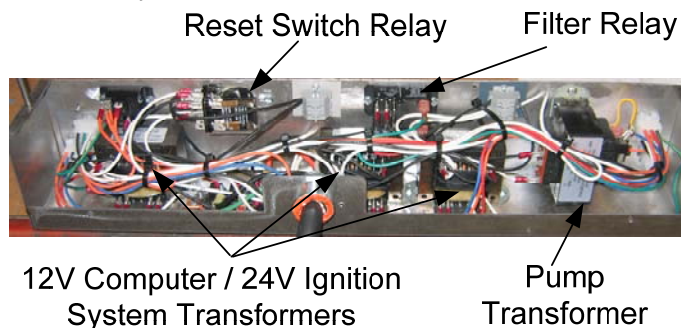



## 1.12 Probe Resistance Chart

<h3 style="text-align: center;">Probe Resistance Chart</h3> <p style="text-align: center;"><i>For use with OCF30™ Series fryers manufactured with Minco Thermistor probes only.</i></p>																	
F	OHMS	C	F	OHMS	C	F	OHMS	C	F	OHMS	C	F	OHMS	C			
60	1059	16	130	1204	54	200	1350	93	270	1493	132	340	1634	171			
65	1070	18	135	1216	57	205	1361	96	275	1503	135	345	1644	174			
70	1080	21	140	1226	60	210	1371	99	280	1514	138	350	1654	177			
75	1091	24	145	1237	63	215	1381	102	285	1524	141	355	1664	179			
80	1101	27	150	1247	66	220	1391	104	290	1534	143	360	1674	182			
85	1112	29	155	1258	68	225	1402	107	295	1544	146	365	1684	185			
90	1122	32	160	1268	71	230	1412	110	300	1554	149	370	1694	188			
95	1133	35	165	1278	74	235	1422	113	305	1564	152	375	1704	191			
100	1143	38	170	1289	77	240	1432	116	310	1574	154	380	1714	193			
105	1154	41	175	1299	79	245	1442	118	315	1584	157	385	1724	196			
110	1164	43	180	1309	82	250	1453	121	320	1594	160	390	1734	199			
115	1174	46	185	1320	85	255	1463	124	325	1604	163	395	1744	202			
120	1185	49	190	1330	88	260	1473	127	330	1614	166	400	1754	204			
125	1195	52	195	1340	91	265	1483	129	335	1624	168	405	1764	207			

## 1.13 ATO (Automatic Top-Off) Service Procedures

The automatic top-off system is activated when the oil level falls below a sensor in the rear of the frypot. A signal is sent to the ATO board to engage the solenoid to the frypot and turn on the ATO pump. The pump draws oil from the JIB (Jug In Box) to a port in the rear of the frypot. Once the oil level has satisfied the sensor, the pump and solenoid turn off.

The ATO board is located inside the box, behind the JIB (see Figure 1). The power for the ATO board is supplied from the transformer box. The power passes through the transformer inside the ATO box to the board.

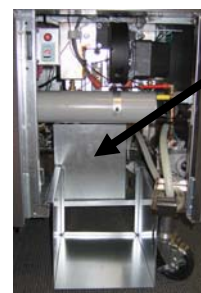

Figure 1 ATO Box

### 1.13.1 ATO (Automatic Top-Off) Troubleshooting

Problem	Probable Causes	Corrective Action
<b>Controller displays TOPOFF OIL EMPTY/CONFIRM</b>	Top off system out of oil.	Fill top off system with oil and press the ▲ (CONFIRM) button.
<b>No power to ATO board</b>	A. J5 connection unplugged B. Fuse blown. C. Transformer malfunction	A. Check to ensure J5 on front of ATO board is fully locked into connector. B. Ensure fuse located on right side of ATO box is not blown. C. Check that proper voltage is present at transformer. See table in section 1.13.2.
<b>Incorrect vat tops off.</b>	A. Wired incorrectly. B. Flexlines connected to wrong vat.	A. Check wiring. B. Switch flexlines to correct vat.
<b>One vat doesn't top off.</b>	A. RTD, solenoid issue, wire connection or ATO board issue.	A. Check RTD, solenoid, wire connections or ATO board.
<b>Frypot tops off cold.</b>	Incorrect setpoint	Ensure setpoint is correct.

Problem	Probable Causes	Corrective Action
<b>Frypots won't top off.</b>	<ul style="list-style-type: none"> <li>A. JIB out of oil</li> <li>B. Supply line from JIB is clogged.</li> <li>C. Probe temperature lower than setpoint.</li> <li>D. Temperature in supply line or JIB is too low.</li> <li>E. Crumb build up around sensor</li> <li>F. ATO board power loss</li> <li>G. Failed solenoid.</li> <li>H. ATO pump failed or over tightened.</li> <li>I. Failed transformer/harness.</li> <li>J. Failed ATO board.</li> <li>K. Top-off manifold solenoid failed closed.</li> <li>L. Jumper missing in ATO board 4 and 5 battery units</li> </ul>	<ul style="list-style-type: none"> <li>A. Ensure the JIB is not out of oil and supply line is in the JIB. Replace JIB and press the ▲ button when prompted to reset top off system.</li> <li>B. Remove supply line from pump and blow air through line towards JIB.</li> <li>C. Check to see that fryer is heating. Fryer temperature must be at least 300°F (149°C). Check probe resistance. If probe is bad, replace the probe.</li> <li>D. Ensure oil is above 70°F (21°C).</li> <li>E. Clean crumbs from opening surrounding sensor.</li> <li>F. Power to the ATO board has been cut off. Restore power to the board and switch all controllers off and on again to readdress system.</li> <li>G. Check solenoid to see if functioning properly.</li> <li>H. Ensure pump is operational. Check voltage to pump. Replace the pump if defective.</li> <li>I. Ensure transformer in ATO box is functioning properly. Check power from transformer to ATO board. Ensure all harnesses are plugged securely into place.</li> <li>J. Check for proper voltages using the pin position chart found on page 1-31. If ATO found defective, replace ATO board.</li> <li>K. A pressure switch opens in the pump with excessive pressure in the top-off manifold, shutting down the pump. Clear or replace solenoid.</li> <li>L. Jumper in J4/J5 missing on ATO #2 board in pins 7 &amp; 8.</li> </ul>
<b>One vat tops off but other vats fail to top off.</b>	<ul style="list-style-type: none"> <li>A. Failed solenoid</li> <li>B. Loose wire connection.</li> </ul>	<ul style="list-style-type: none"> <li>A. Check power to the pump. A hot pump suggests a failed solenoid.</li> <li>B. Ensure all wiring harnesses are securely connected to ATO board and solenoids.</li> </ul>

Problem	Probable Causes	Corrective Action
<p style="text-align: center;"><b>3000 displays SERVICE REQUIRED – ATO BOARD</b></p>	<p>A. Loose or bad fuse B. Bad Connection C. ATO Board power loss</p>	<p>A. Ensure fuse on right side of ATO box is secure and good. If the controller above the ATO box is missing power, check the fuse below the component box.</p> <p>B. With the controller OFF, press TEMP button and ensure the ATO software version appears. If not, the connection between the controller and the ATO board may be bad. Ensure the 6-pin CAN connectors are tight between controller (J6 and J7) and ATO (J9 or J10) boards.</p> <p>C. Power to the ATO board has been cut off. Ensure there is correct voltage to the ATO transformer. Restore power to the board and clear any service required errors.</p>

### 1.13.2 ATO (Automatic Top-Off) Board Pin Positions and Harnesses

Connector	From/To	Harness #	Pin #	Function	Voltage	Wire Color
J8	Solenoids	8075161 8075162- (4 or 5 battery)	1	Output DV - Vat #1	Ground	Green
			2	Output FV - Vat #1		Red
			3	Output DV - Vat #2		Green
			4	Output FV - Vat #2		Red
			5	Output DV - Vat #3		Green
			6	Output FV - Vat #3		Red
	Top Off Pump Relay		7	Top Off Pump	12VDC	Red
	JIB Reset Switch		8	JIB Reset	16VDC	Red
	Solenoids	8075161 8075162- (4 or 5 battery)	9	24VAC DV - Vat #1	24VAC	White
			10	24VAC FV - Vat #1		Black
			11	24VAC DV - Vat #2		White
			12	24VAC FV - Vat #2		Black
			13	24VAC DV - Vat #3		White
			14	24VAC FV - Vat #3		Black
	Top Off Pump Relay		15	Ground	12VDC	Black
	JIB Reset Switch		16	Ground	16VDC	Black
J4 (Rear) / J5 (Front)	Transformer	8074553	1	24VAC Ret	24VAC	Orange
			2	24VAC		Blue
			3			
			4			
			5	12VAC Ret	12VAC	Red
			6	12VAC		Brown
	ATO 4 and 5 Battery Jumper	8075163	7	Jumper	Ohm	Black
			8	Jumper		Black
J3 - Vat 5&6 J2 - Vat 3&4 J1 - Vat 1&2	ATO RTD	1080501 (FV) 1080502 (DV)	1	DV - Probe Ground	Ohm	White
			2	DV - Probe		Red
			3	FV - Probe Ground		White
			4	FV - Probe		Red
J6			1			
			2			
J10	Network Resistor (pins 2 & 3) or to next ATO Board (4 & 5 vat units)	8074552	1	Ground		Black
			2	CAN Lo		Red
			3	CAN Hi		White
			4	5VDC+	5VDC	Black
			5	24VDC	24VDC	Red
			6	Ground		White
J9	3000 J7	8074646	1	Ground		Black
			2	CAN Lo		Red
			3	CAN Hi		White
			4	5VDC+	5VDC	Black
			5	24VDC	24VDC	Red
			6	Ground		White

### 1.13.3 Replacing the ATO Board, ATO Pump Relay or Transformer

Disconnect the fryer from the electrical power supply. Locate the ATO box (see Figure 1 on page 1-28), behind the JIB (Jug In Box). Remove the cover to expose the transformer and ATO board (see Figure 2). Mark and unplug any wires or harnesses. Replace the defective component and reattach all wires or harnesses. Replace the cover. Once replaced, reconnect the power. **CYCLE POWER TO ENTIRE FRYER SYSTEM.** See section 1.13.6 on page 1-32 to reset control power. Check software version and if necessary update the software. If a software update is necessary, follow the instructions to update the software in section 1.15.

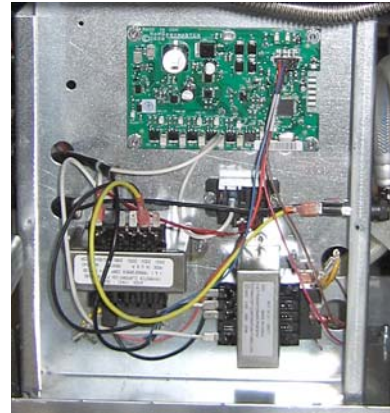

Figure 2

Remove and restore power to ALL controllers after power has been restored to the ATO board. Press the TEMP button on one of the 3000 controllers, with the controller in the OFF position, to verify software version of the ATO. If the version is not visible, the ATO may not be connected properly.

### 1.13.4 Replacing the ATO Pump

Disconnect the fryer from the electrical power supply. Locate the ATO pump (see Figure 3), behind the ATO box. Mark and unplug any wires or harnesses. Press up from the bottom on the quick disconnects to release the plumbing (see Figure 4). The plumbing can be pulled from the pump. Loosen the four nuts attaching the pump to the pump tray. Replace the defective component and reverse above steps. Once replaced, reconnect the power.



Figure 3



Figure 4

### 1.13.5 Replacing the ATO Solenoids

Disconnect the fryer from the electrical power supply. Locate the top off manifold in the rear of the fryer. The top off manifold is the smaller of the two manifolds. The solenoids are attached to the manifold (see Figure 5). Mark and unplug any wires. Replace the defective component and reattach all wires or harnesses. Once replaced, reconnect the power.

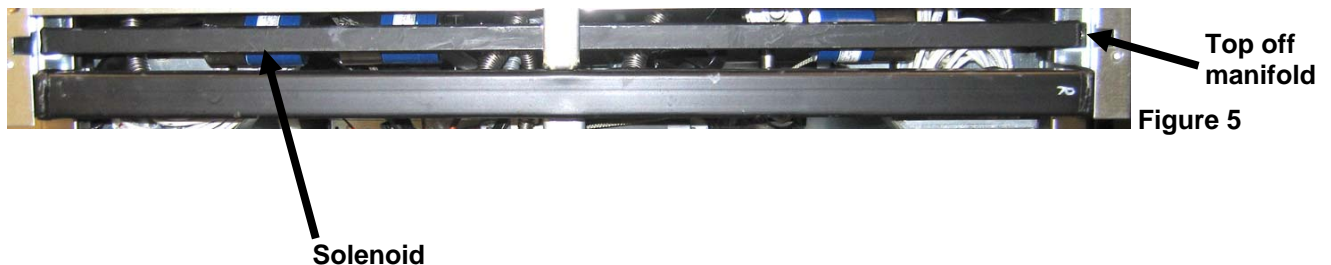

Figure 5

### 1.13.6 Control Power Reset Switch

The control power reset switch, is a momentary rocker switch located below the left control box (see Figures 6), that resets all power to all the controllers and boards in the fryer. It is necessary to reset all power after replacing any controller or board. Press and hold the switch for at least ten seconds when resetting the control power to ensure power has sufficiently drained from boards.



Figure 6

### 1.13.7 Testing ATO RTD Probes.

The controller features a quick way to compare the temperature of the ATO RTD to the vat temperature. This is useful for diagnosing ATO issues.

With the controller OFF, press and hold the TEMP button. The controller will display AIF and ----- followed by ATO and current resistance temperature. Ignore the AIF display. It shows ---- if not installed. Compare the resistance of the ATO probe against the controller reading. If the values differ greatly a harness issue may exist.

### 1.13.8 Replacing ATO Probe

See steps 1.9.2 on page 1-8.

## 1.14 Controller Service Procedures

### 1.14.1 Controller Troubleshooting

Problem	Probable Causes	Corrective Action
<b>No Display on Controller.</b>	<ul style="list-style-type: none"> <li>A. Controller not turned on.</li> <li>B. No power to the fryer.</li> <li>C. Controller has failed.</li> <li>D. Damaged controller wiring harness.</li> <li>E. Power supply component or interface board has failed.</li> </ul>	<ul style="list-style-type: none"> <li>A. Press the ON/OFF switch to turn the controller on.</li> <li>B. Verify controller power cord is plugged in and that circuit breaker is not tripped.</li> <li>C. Swap the controller with a controller known to be good. If controller functions, replace the controller.</li> <li>D. Swap with a harness known to be good. If controller functions, replace the harness.</li> <li>E. If any component in the power supply system (including the transformer and interface board) fail, power will not be supplied to the controller and it will not function.</li> </ul>
<b>Controller displays FILTER BUSY.</b>	<ul style="list-style-type: none"> <li>A. Another filtration cycle is still in process.</li> </ul>	<ul style="list-style-type: none"> <li>A. Wait until the previous filtration cycle ends to start another filtration cycle. This may take up to one minute. If filter busy is still displayed with no activity, remove and restore <b>ALL</b> power to the fryer.</li> </ul>

<b>Problem</b>	<b>Probable Causes</b>	<b>Corrective Action</b>
<b>Controller displays CALL TECH</b>	Typically shown during software update. Also may be that parameter data has been corrupted or lost.	Press the FILTER button to bypass and continue.
<b>Controller displays RECOVERY FAULT.</b>	Recovery time exceeded maximum time limit for two or more cycles.	Silence the alarm by pressing the ▲ button. Check that fryer is heating properly. Maximum recovery for a gas fryer is 2:25.
<b>Controller displays SERVICE REQUIRED followed by the error .</b>	An error has occurred.	Press YES to silence alarm. The error is displayed three times. See list of issues in section 1.14.4. Fix issue. The controller displays <b>SYSTEM ERROR FIXED? YES/NO.</b> Press YES. Pressing NO will allow the fryer to cook but the error will be redisplayed every 15 minutes.
<b>Controller displays CHANGE FILTER PAPER?</b>	Daily filter paper change prompt has occurred.	Press ▲ (YES), follow prompts and change the filter paper.
<b>Controller display is in wrong temperature scale (Fahrenheit or Celsius).</b>	Incorrect display option programmed.	Fryers using the 3000 controller can toggle between F° to C° by pressing the ✓ button until Main Menu changing to Product setup is displayed. Press ► to scroll to Tech Mode and press ✓. Enter 1658. Press the scan button. The controller displays <b>OFF.</b> Turn the controller on to check temperature. If the desired scale is not displayed, repeat. Fryers using the CM3.5 should refer to the separate Fryer Controllers User's Manual.
<b>Controller displays HOT-HI-1.</b>	Frypot temperature is more than 410°F (210°C) or, in CE countries, 395°F (202°C).	This is an indication of a malfunction in the temperature control circuitry, including a failure of the high-limit thermostat.
<b>Controller displays HI-LIMIT.</b>	Controller in high-limit test mode.	This is displayed only during a test of the high-limit circuit and indicates that the high-limit has opened properly.
<b>Controller displays LOW TEMP alternating with temperature.</b>	Frypot temperature is between 180°F (82°C) and 315°F (157°C).	This display is normal when the fryer is heating and out of melt cycle until the temperature reaches ±2° of setpoint.
<b>Controller displays LO or LOW TEMP.</b>	Frypot temperature has dropped more than 21°F (12°C) for CM3.5 or 40°F (17°C) for 3000 controllers below setpoint in idle mode or 45°F (25°C) in cook mode.	This display is normal for a short while if a large batch of frozen product is added to the frypot or if the fryer is not heating properly.
<b>Controller displays LOW TEMP, heating indicator cycles on and off normally but fryer does not heat.</b>	A. Failed controller. B. Damaged controller wiring harness.	A. Replace controller. B. Replace controller wiring harness.

<b>Problem</b>	<b>Probable Causes</b>	<b>Corrective Action</b>
<b>Controller displays CLOSE DRAIN VALVE.</b>	Drain valve is open or switch is out of adjustment or failed.	Ensure all drain valves are completely closed and that microswitches are adjusted and working.
<b>Controller displays ERROR RM SDCRD</b>	Defective SD Card	Replace card with another card.
<b>Controller displays TEMP PROBE FAILURE.</b>	Problem with the temperature measuring circuitry including the probe.	This indicates a problem within the temperature probe circuitry. Check resistance of probe. If faulty, replace probe.
<b>Controller displays PROBE FAILURE with alarm sounding.</b>	Damaged controller wiring harness or connector.	Swap the controller wiring harness with one known to be good. If problem is corrected replace the harness.
<b>Controller displays HEATING FAILURE.</b>	Open drain valve, failed controller, failed interface board, open high-limit thermostat.	Is displayed if the fryer loses its ability to heat oil. It is also displayed when the oil temperature is above 450°F (232°C) and the high-limit thermostat has opened, halting the heating of the oil.
<b>Controller will not go into program mode or some buttons do not actuate.</b>	Failed controller.	Replace controller
<b>Controller displays LOW TEMP, heating indicator cycles on and off normally but fryer does not heat.</b>	A. Failed controller. B. Damaged controller wiring harness.	A. Replace controller. B. Replace controller wiring harness.
<b>Controller displays HEATING FAILURE with alarm sounding. Heating indicator is on, but fryer is not heating.</b>	Drain valve not fully closed.	Ensure all drains are fully closed. Using the ON/OFF switch, turn the controller OFF and then ON again.
<b>Controller displays HEATING FAILURE and alarm sounds, but fryer operates normally (false alarm).</b>	Failed controller.	Replace controller.
<b>Controller displays HI 2 BAD.</b>	Controller in high-limit test mode.	This is displayed only during a test of the high-limit circuit and indicates that the high-limit has failed.
<b>Controller displays software for only 3000 or ATO board.</b>	Loose or damaged harness	Check that all harnesses between 3000's and ATO are secure and no pins are pushed out or broken.



### 1.14.2 3000 Controller Useful Codes

To enter any of the following codes: Press and hold the ✓ button until *MAIN MENU* changing to *PRODUCT SETUP* is displayed. Press ► to scroll to *TECH MODE* and press *TECH MODE ENTER CODE* is displayed. Press the ✓ button. Enter a code number below:

- **Change Fryer Type, CE/Non-CE, Fresh Oil Setup, Waste Oil Setup and Energy Type – Enter 7628.**
- **Clear E-Log, Clear Passwords, Change Lane Count, Adjust Max Cook Temp and Perform High Limit Test, – Enter 3000.**
- **Reset Factory Menu - Enter 3322.** The controller display flashes and quickly counts from 1-40 and switches to *OFF*. (**NOTE:** This will delete any hand-entered menu items).
- **Reset *BADCRC* Message -** Disconnect board locator plug (J3). Reinsert plug. Enter **9988**. Controller display switches to *OFF*. Remove and then restore power to the controller using the 20-pin plug.
- **Change from F° to C° - Enter 1658.** The controller displays *OFF*. Turn the controller on and check temperature to see the temperature scale. If the desired scale is not displayed, repeat.
- **Reset *RECOVERY FAULT CALL SERVICE* – Enter 0042.**

### PASSWORDS

**Product Setup Mode:** Press and hold the ✓ button until *MAIN MENU* changing to *PRODUCT SETUP* is displayed. Press the ✓ button. *ENTER CODE* is displayed. Enter **1650**.

**Vat Setup Mode:** Press and hold the ✓ button. *MAIN MENU* changing to *PRODUCT SETUP* is displayed. Press ► to scroll to *VAT SETUP* and press ✓. *ENTER CODE* is displayed. Enter **1656**.

**Tech Mode:** Press and hold the ✓ button until *MAIN MENU* changing to *PRODUCT SETUP* is displayed. Press ► to scroll to *TECH MODE* and press ✓. *TECH MODE* is displayed. Press the ✓ button. *ENTER CODE* is displayed. Enter **3000** or a code from above.

### 1.14.3 Service Required Errors

A **SERVICE REQUIRED** error alternating with **YES** displays on the controller. After **YES** is pressed the alarm is silenced. The controller displays an error message from the list below three times with the location of the error. Then the controller displays **SYSTEM ERROR FIXED? YES/NO**. Press **YES** if fixed. If **NO** is chosen the system returns to cook mode for 15 minutes then redisplay error until issue is fixed.

#### 1.14.4 Error Log Codes

Code	ERROR MESSAGE	EXPLANATION
E03	ERROR TEMP PROBE FAILURE	TEMP Probe reading out of range
E04	HI 2 BAD	High limit reading is out of range.
E05	HOT HI 1	High limit temperature is past 410°F (210°C), or in CE countries, 395°F (202°C)
E06	HEATING FAILURE	A component has failed in the high limit circuit such as controller, interface board, contactor or open-high limit.
E08	ERROR ATO BOARD	ATO board connection lost; ATO board failure
E17	ERROR ATO PROBE	ATO RTD reading out of range
E20	INVALID CODE LOCATION	SD card removed during update
E21	FILTER PAPER PROCEDURE ERROR (Change Filter Paper)	25-hour or customer-set timer has expired.
E22	OIL IN PAN ERROR	Oil may be present in the filter pan.
E25	RECOVERY FAULT	Recovery time exceeded maximum time limit. Recovery time should not exceed 1:40 for electric.
E27	LOW TEMP ALARM	Oil temperature has dropped 40°F (17°C) below setpoint temperature in idle mode or 45°F (25°C) in cook mode. (This message may appear if a product is dropped and the start cook button is not pressed immediately or if too large of cook loads are dropped.)

## 1.14.5 3000 Controller Menu Summary Tree

Reflected below are the major programming sections in the 3000 and the order in which submenu headings will be found under the sections in the 3000 Operation Manual (819-6985).

### Adding New Product Menu Items

See section 4.6-4.8

Filter Menu .....	1.9
[With computer ON, press and hold FILTER button]	
Filter	
Clean and Filter	
Dispose	
Fill Vat From Bulk (Bulk option only)	
Boil Out [With computer OFF, press and hold FILTER button]	
Info Mode .....	1.5
[Press and hold ✓(check) button]	
Last Dispose Stats	
Daily Stats	
Selected Period Stats	
Last Load Stats	
Main Menu and Tech Modes	
[With computer OFF, press and hold ✓(check) button 10 seconds, displays Main Menu - Product Setup]	
Product Setup .....	1.6-1.8
[Enter 1650]	
Select Product	
Long Name	
Short Name	
Cooking Mode	
1 Time	
1 Tempr	
1 Sensitivity	
1 Alarm Time (Shake)	
1 Alarm Name (Shake)	
1 Alarm Mode (Shake)	
1 Alarm Tone (Shake)	
2 Alarm Time (Shake) Time entered here, produces a 3 <sup>rd</sup> alarm time.	
Filter Prompt	
Instant On	
Hold Time	
Load Standard (Load Default Product Menu)	
Vat Setup .....	1.4
[Enter 1656]	
System .....	1.4
Language	
2 <sup>nd</sup> Language	
Locale (CE or Non-CE)	
Energy (Gas or Elec)	
Type (Vat)	
System Volume (Sound Level)	
Tempr Format (F or C)	
Exit Melt Tempr	
Cool Mode Tempr	
Cool Mode Default	
Fresh Oil	
Waste	
Drain Switch	
Recovery Alarm	
Basket Lift	
Hold Time	
Is Vat Full?	
Time/Date .....	1.4
DST(Daylight Savings Time) Setup.....	1.4
Filter .....	1.4
Cooks til Filter	
Filter Lockout	
EOD Filter Timer	
EOD Filter Time	
Flushing Timer	
Boil Out Timer	
1 Polish Timer	
1 Polish Prompt Time	
1 Polish Duration	
1 Polish Start Tempr	
E-Log List of last 10 error codes .....	1.4
Change Password .....	1.4
Tech Mode	
[Enter 3000]	
Clear E-Log	
Clear Passwords	
Lane Count	
Hold Mode	
Max Cook Tempr	
Hi-Limit Test	
Enable Filters	
Enable Cooks	

**NOTE:** Items in gray are associated with the optional COOKS and FILTERS modes of the computer. If these modes are disabled, the steps shown in gray will not appear in the programming steps.

**NOTE:** Three alarm times are programmable. The steps for programming the 2<sup>nd</sup> alarm are just like the first. A third alarm prompt follows completion of the 2<sup>nd</sup>.

**NOTE: If the lane count doesn't change, set the basket lift to disabled in Vat Setup.**

**NOTE: A programming option is available in TECH MODE called "Hold Mode" that will either allow the product's hold time to count down in the background or count down in the foreground.**

### 1.14.6 3000 Controller Pin Positions and Harnesses

Connector	From/To	Harness PN	Pin #	Function	Voltage	Wire Color	
J2	Interface Board to Controller	8075165 SMT Controller to Interface Board Harness	1	12VAC In	12VAC	Orange	
			2	Ground			
			3	12VAC In	12VAC		
			4	FV Heat Demand			
			5	V Relay	12VDC		
			6	DV Heat Demand			
			7	R/H B/L	12VDC		
			8	Analog Ground			
			9	L/H B/L	12VDC		
			10	ALARM			
			11	Sound Device	5VDC		
			12	ALARM			
			13	FV Probe			
			14	Common Probes			
			15	DV Probe			
			16				
			17				
			18				
			19	Blower Relay	12VDC	Orange	
			20				
J3	Locator Harness Interface Board Ground to Controller	1080485	1	Vat #1		Black	
		1080486	2	Vat #2			
		1080487	3	Vat #3			
		1080488	4	Vat #4			
		1080489	5	Vat #5			
			6				
J4	Drain Switch	8075159 (FV) 8075160 (DV)	1	FV Drain		Black	
			2	FV Drain		Red	
			3	DV Drain		Black	
			4	DV Drain		Red	
J6	Previous 3000 J7 or Network Resistor	8074546 Controller Communication Harness	1	Ground		Black	
			2	CAN Lo		Red	
			3	CAN Hi		White	
			4				
			5				
			6				
J7	ATO J1 or Next 3000 J6	8074646 Controller Communication Harness	1	Ground		Black	
			2	CAN Lo		Red	
			3	CAN Hi		White	
			4				
			5				
			6				

## 1.15 Loading and Updating Software Procedures

Updating the software takes approximately 30 minutes. The software only needs to be loaded in **ONE** controller or the far left controller in a battery and it will update **all** the controllers and boards in the system. Press the TEMP button to check current 3000 and ATO software version. Remove the bezel by removing the screws under the bottom of the bezel. Remove the two screws securing the controller allow it to swing down. Remove the two screws on the left side cover plate of the 3000 controller or far left controller in a battery.

To update the software, follow these steps carefully:

Left Display	Right Display	Action
OFF	OFF	With the controller folded down, insert the SD card, with the contacts facing down and the notch on the bottom right (see Figure 7 and 8), into the slot on the left side of the 3000 controller. <b>ENSURE THE CARD IS FULLY INSERTED INTO THE SD CARD SLOT.</b>
UPGRADE IN PROGRESS	WAIT	None required.
CC UPDATING	PERCENTAGE COMPLETE	None required.
BOOT	BLANK	None required.
CALL	TECH	If this message is displayed, press the FILTER button and the software load will continue.
UPGRADE IN PROGRESS	WAIT	None required.
IF_COOK HEXand IF_ATO HEX	PERCENTAGE COMPLETE	None required.
REMOVE SD CARD	100	Remove the SD card using the fingernail slot on the top of the SD card.
CYCLE POWER.	BLANK	Cycle the control power using the hidden reset switch under the far left control box. <b>ENSURE THE SWITCH IS HELD FOR 10 SECONDS.</b>
BOARD ID	Zero or a number from 1-4	Press the IO (Power) button.
SYSTEM TYPE	OCF30	Press the ▼ or ▲ to choose correct fryer type. OCF30 (Frymaster)
SYSTEM TYPE	OCF30	Press ►. Ensure correct fryer type is displayed.
TYPE	GL30	Press the ▼ or ▲ to select proper fryer model. One of several fryer models may be displayed.
TYPE	GL30	Once proper fryer model is displayed, press ►.
EXIT	EXIT	Press the ✓ (check) button.
OFF	OFF	<b>With the controller displaying OFF, VERIFY software update by pressing the TEMP button to check updated 3000 version on each controller. 3000 should display software version 40.0159.03 for 3000 and 35.0157.00 for ATO.</b>
OFF	OFF	Once the software has been updated and the versions are correct, replace the cover and screws covering the SD card slot. Replace the screws attaching the controller and replace the bezel and screws.
OFF	OFF	Using the instruction sheet 819-6806, perform tech mode setup and vat setup.
OFF	OFF	Set the current date and time using instructions 819-6806.



1-39 Figure 7



Figure 8

# 1.16 Principal Wiring Connections

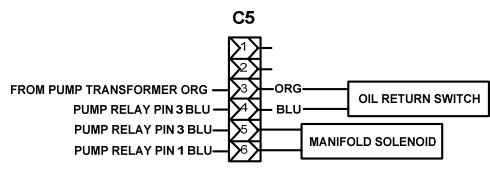
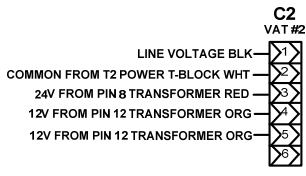
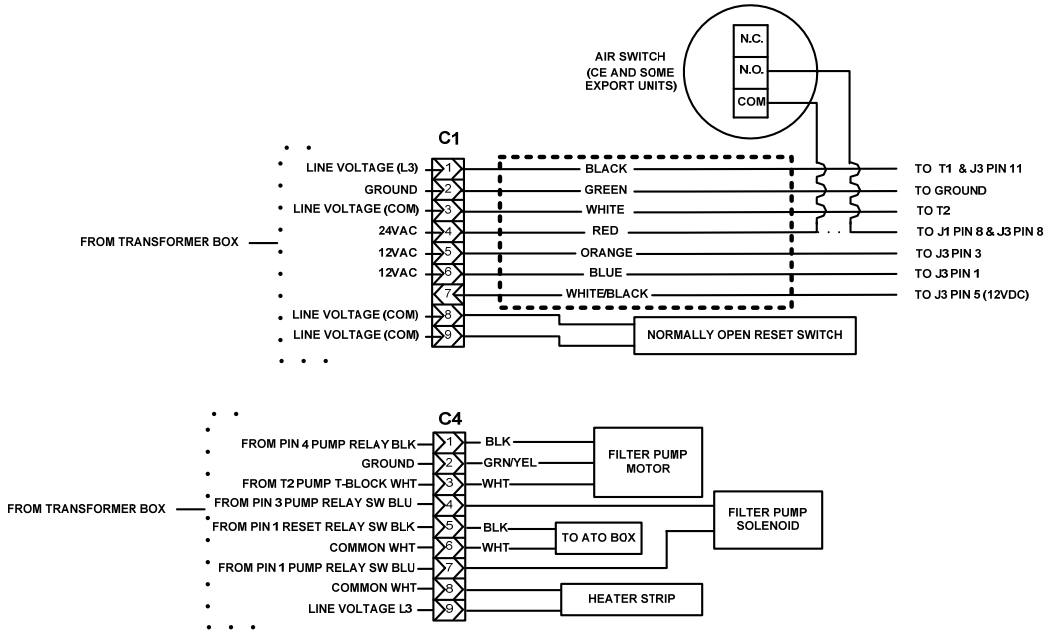
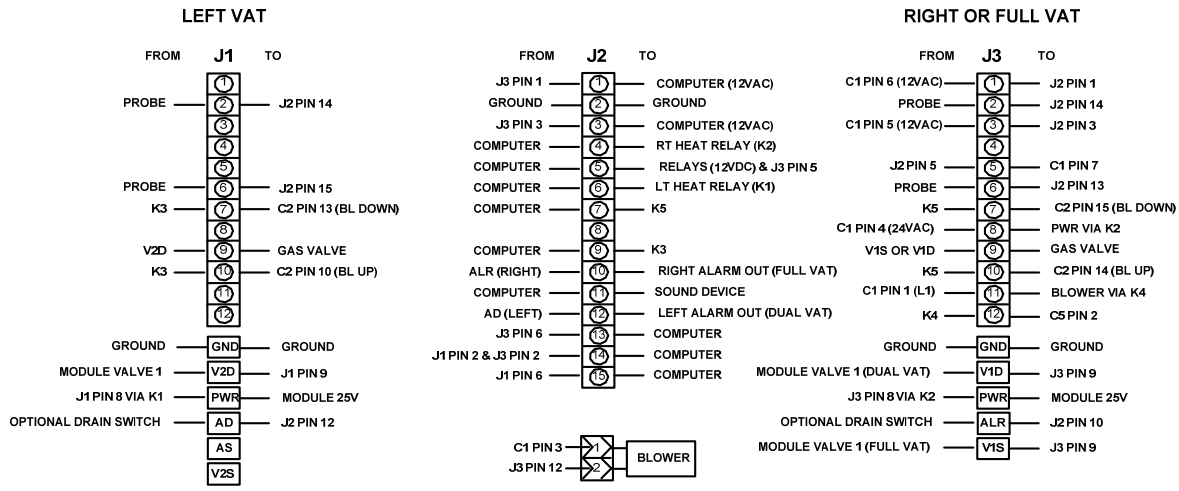

# 1.17 Wiring Diagrams

## 1.17.1 FPG230/430 Wiring 120V, CE and Export

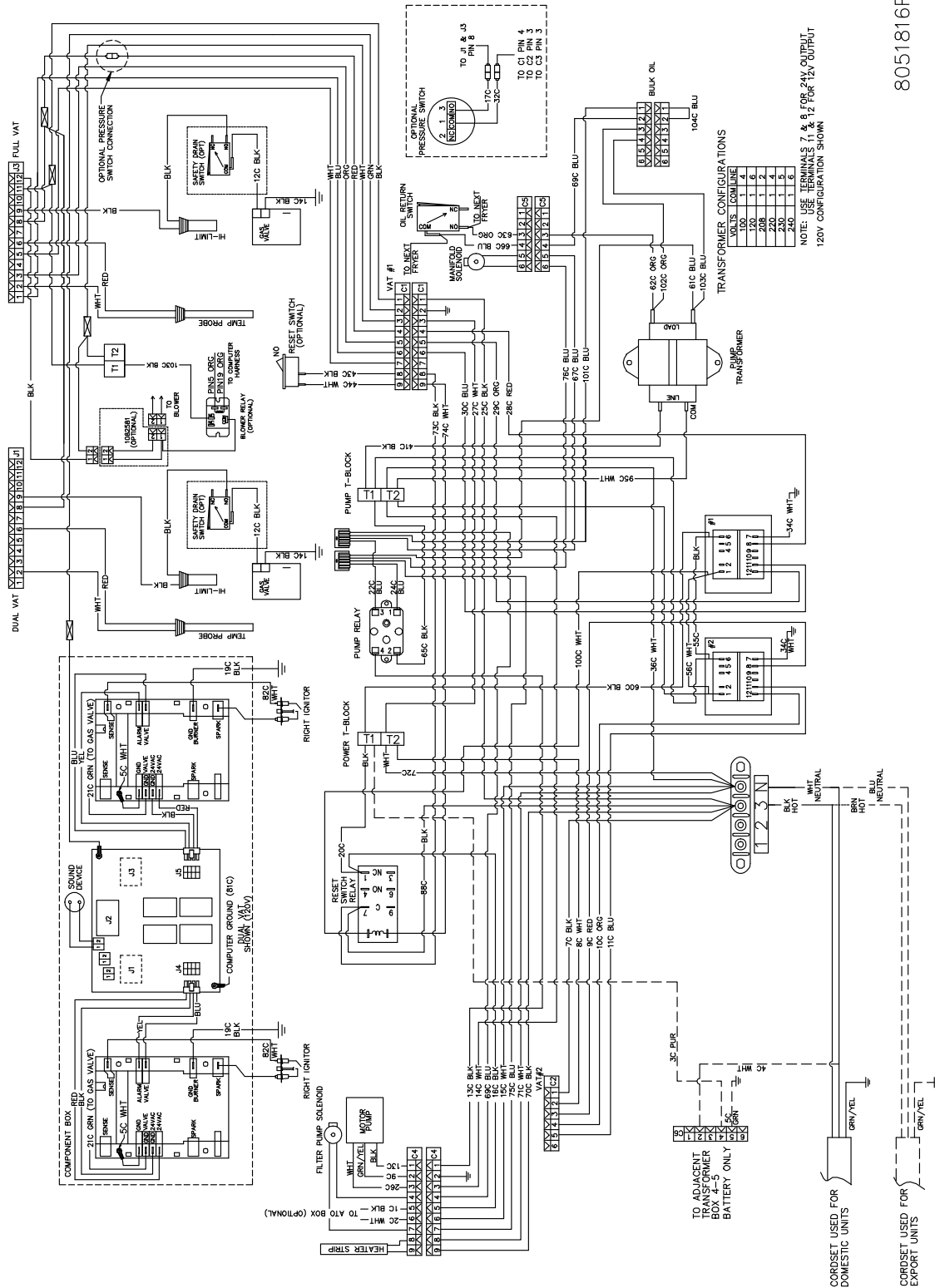

8051816F

# 1.17.1.2 FPGL230/430 Wiring 250V Australia

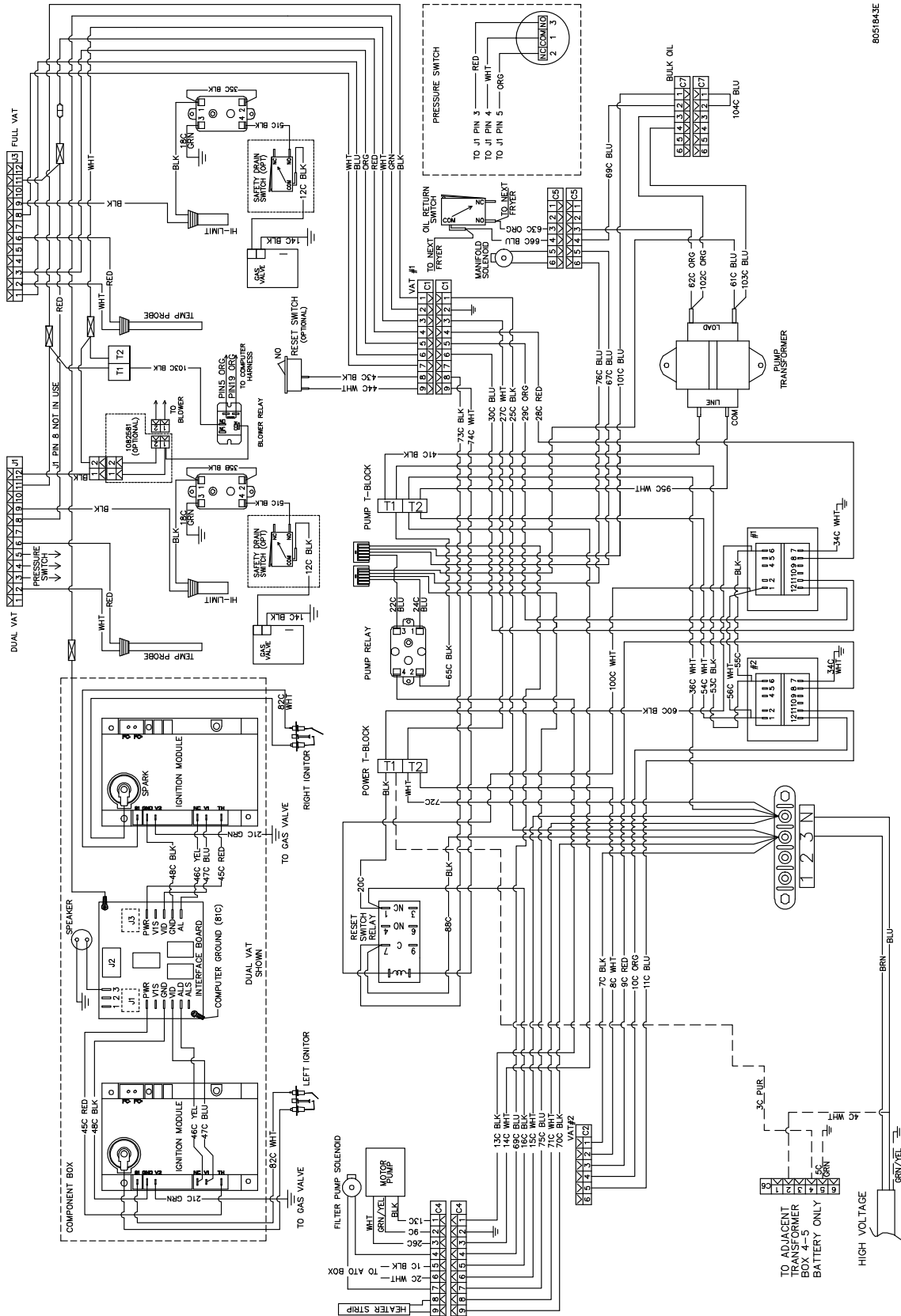

8051843E



# 1.17.2 FPG1330 Wiring 120V, CE and Export

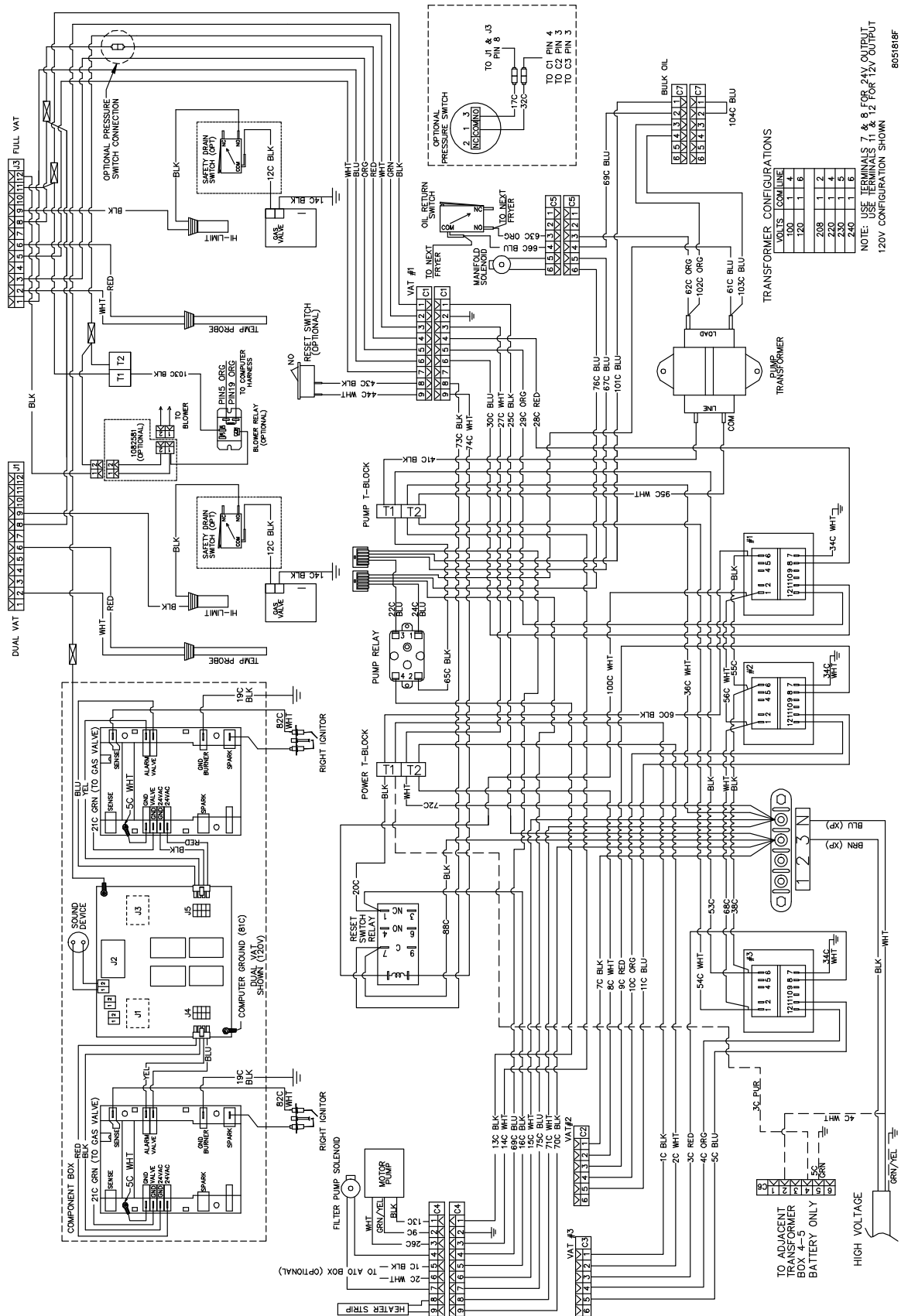

8051818F

1.17.2.2

FPGL330 Wiring 250V Australia

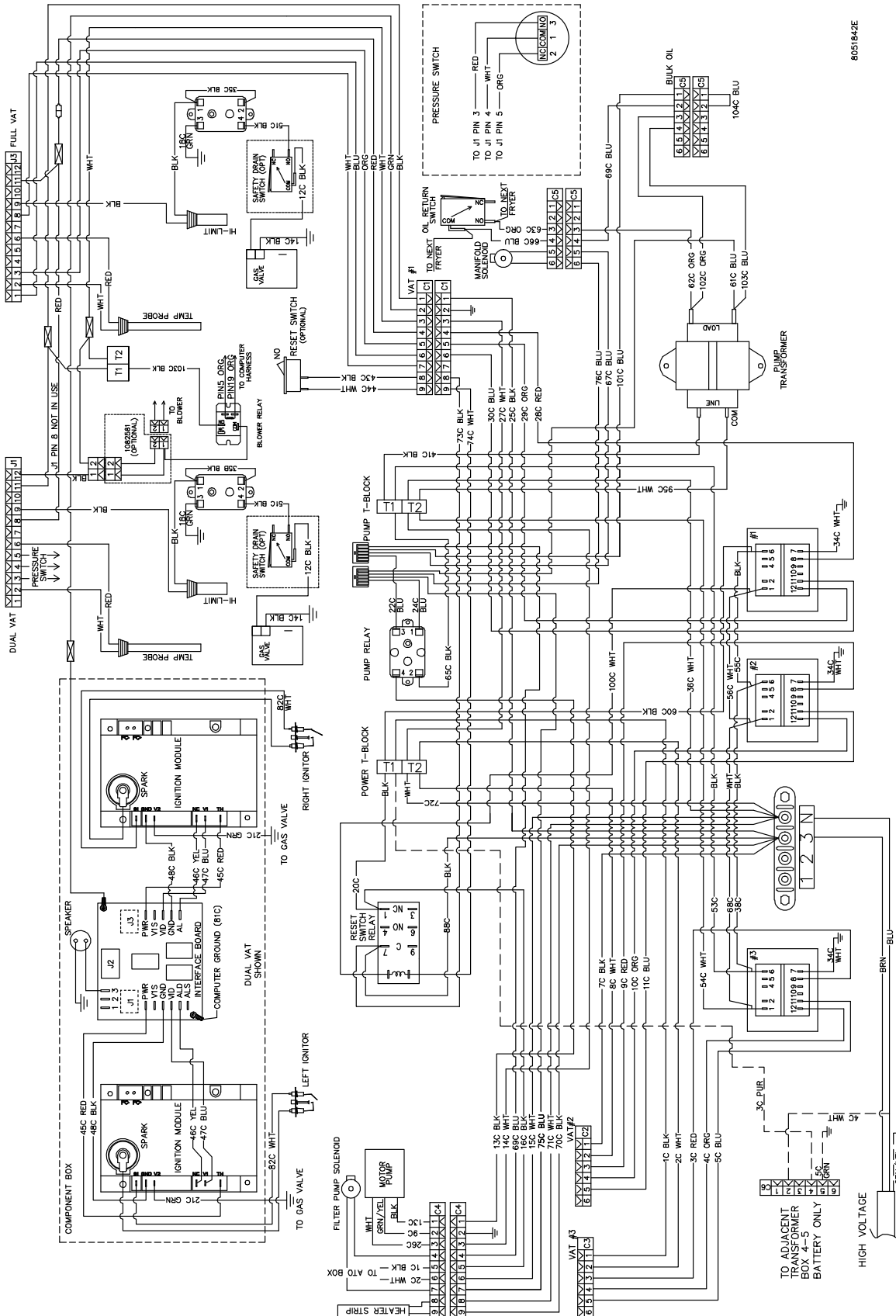

8051842E

### 1.17.3 FPGL430 Extra Transformer Box Wiring

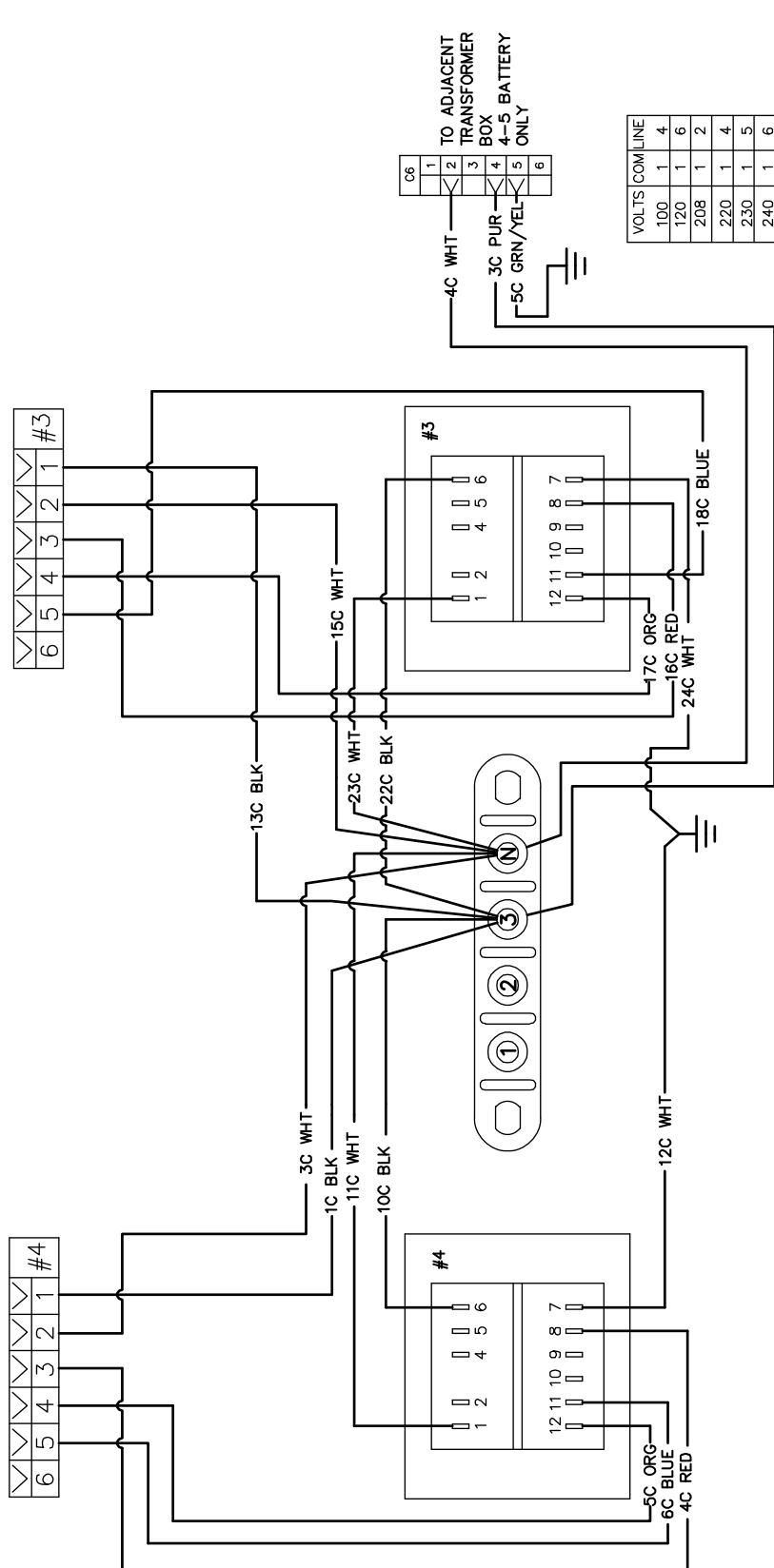

**120V CONFIGURATION SHOWN**  
**8051819A**

NOTE: USE TERMINALS 7 AND 8 FOR 24V OUTPUT.  
 USE TERMINALS 11 AND 12 FOR 12V OUTPUT.

### 1.17.4 Modular Basket Lift (100/120V)

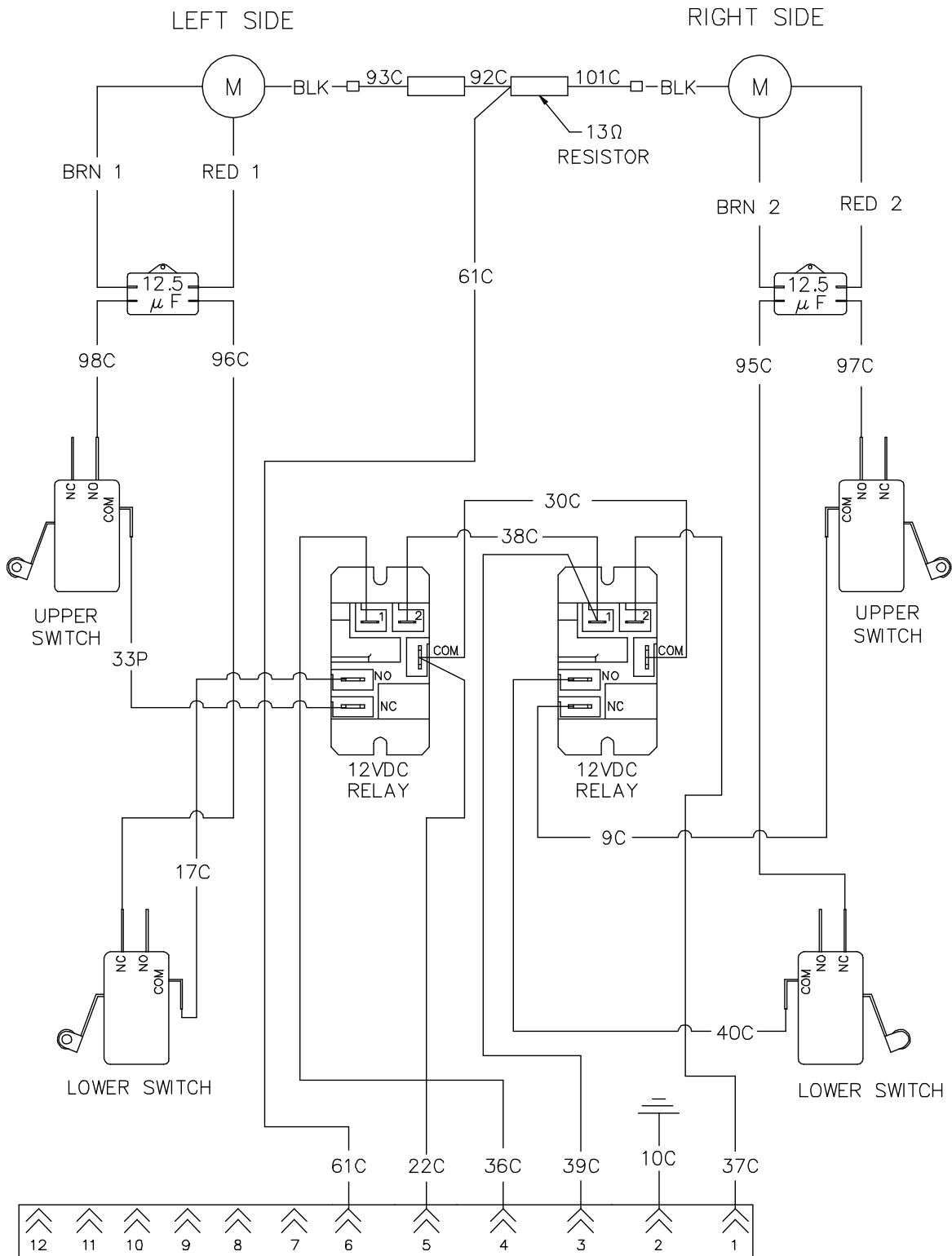

REFERENCES TO LEFT & RIGHT ARE  
FROM THE REAR OF THE FRYER

8050555E

# 1.17.5 Modular Basket Lift (208/250V)

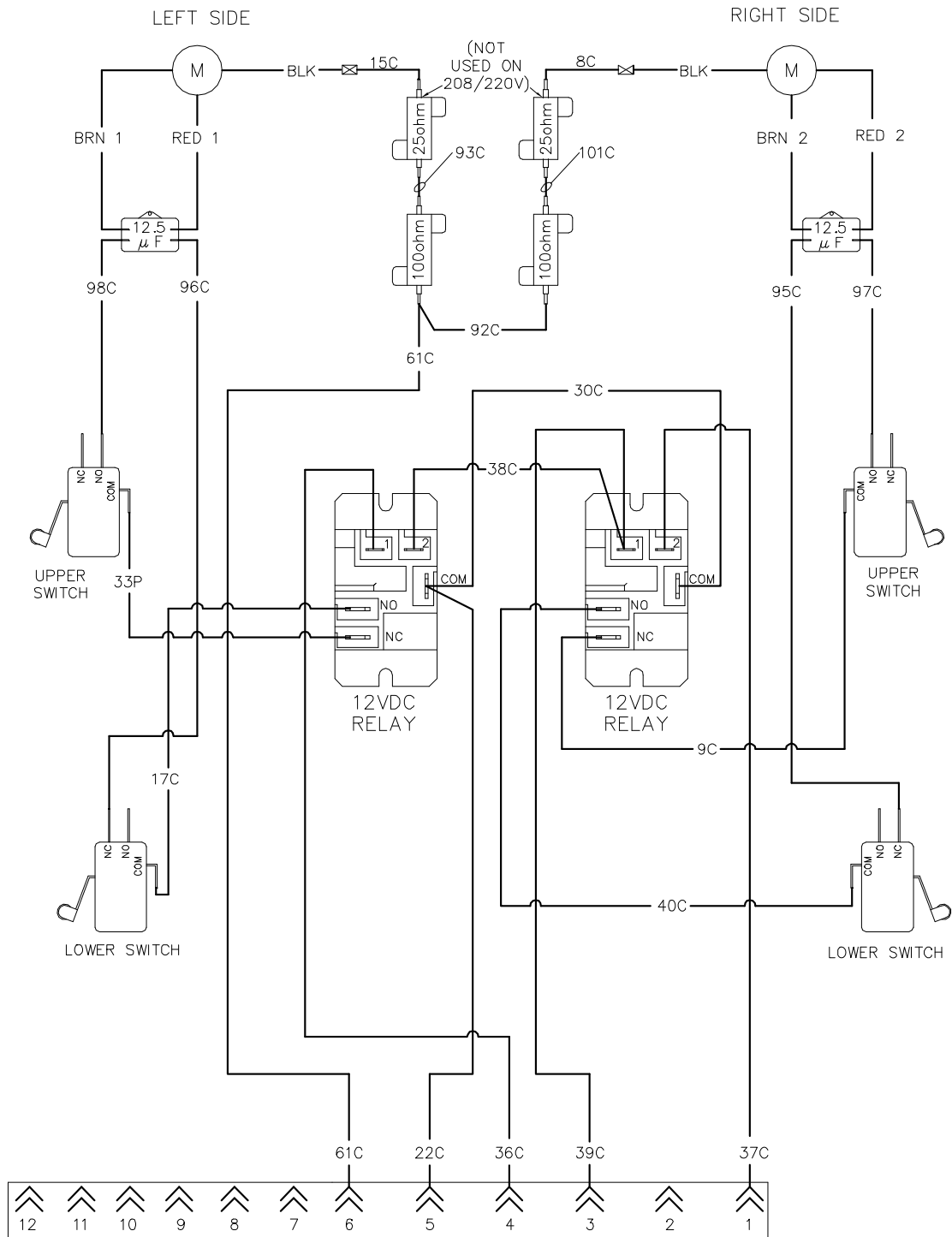

REFERENCES TO LEFT & RIGHT ARE FROM THE REAR OF THE FRYER

8050888D

### 1.17.6 Basket Lift Interface Harness

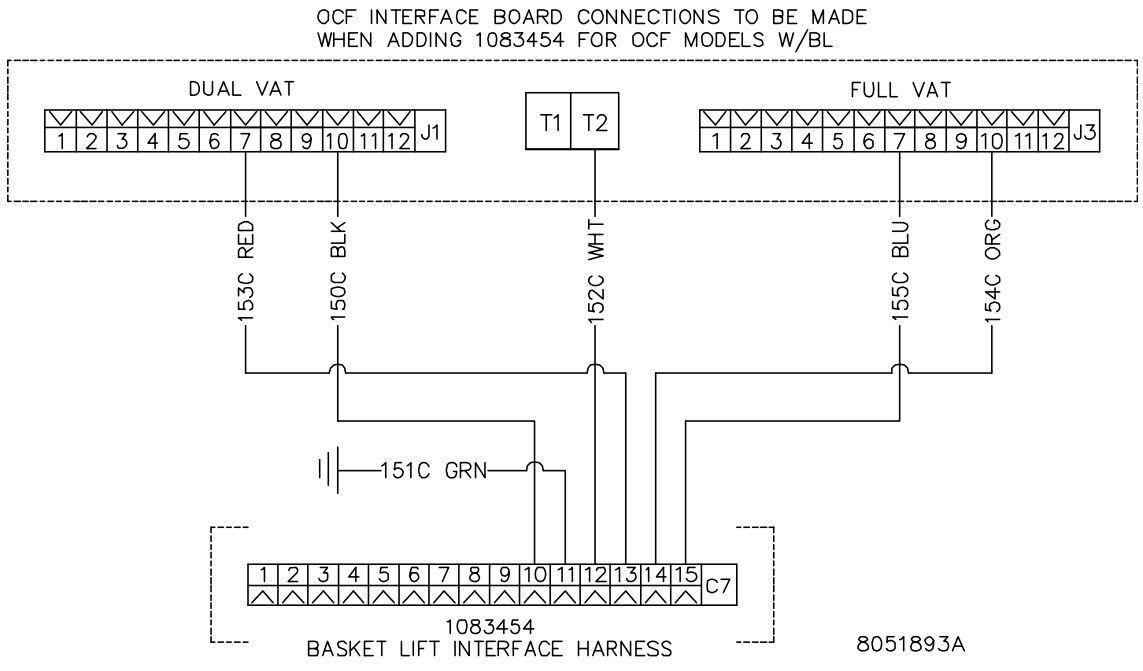

1.18 Simplified Wiring Diagrams  
 1.18.1 FPGL30 Series Full Vat with Dual Spark Module

**FPGL30 SERIES – FULL-VAT WITH ONE DUAL-SPARK IGNITION MODULE**  
 (ONE DUAL FUNCTION HEAT/BLOWER RELAY (K3))

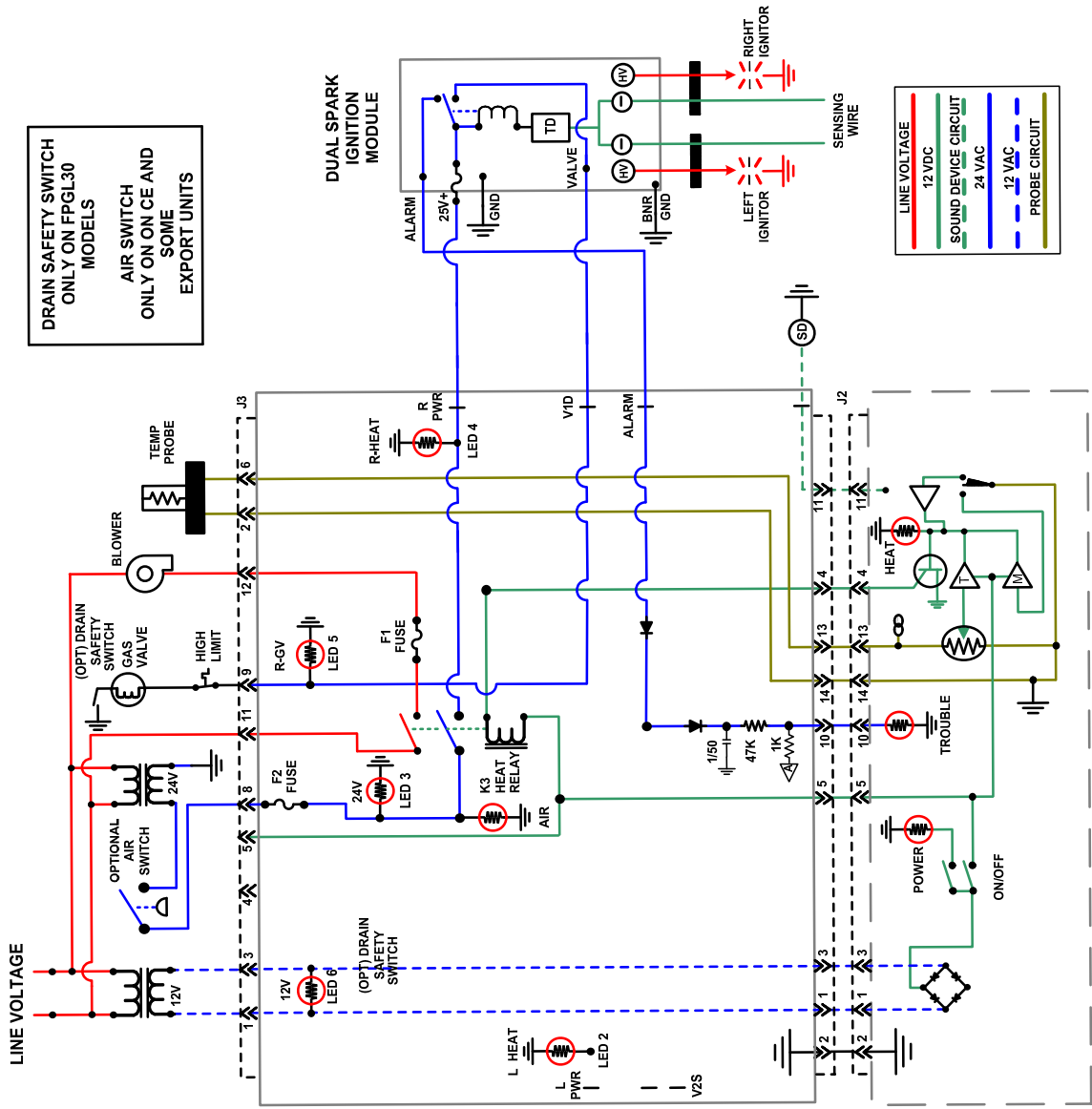

1.18.2 FPGL30 Series Full Vat Single Spark Module excluding Australia

FPGL30 SERIES – FULL-VAT – SINGLE SPARK MODULES

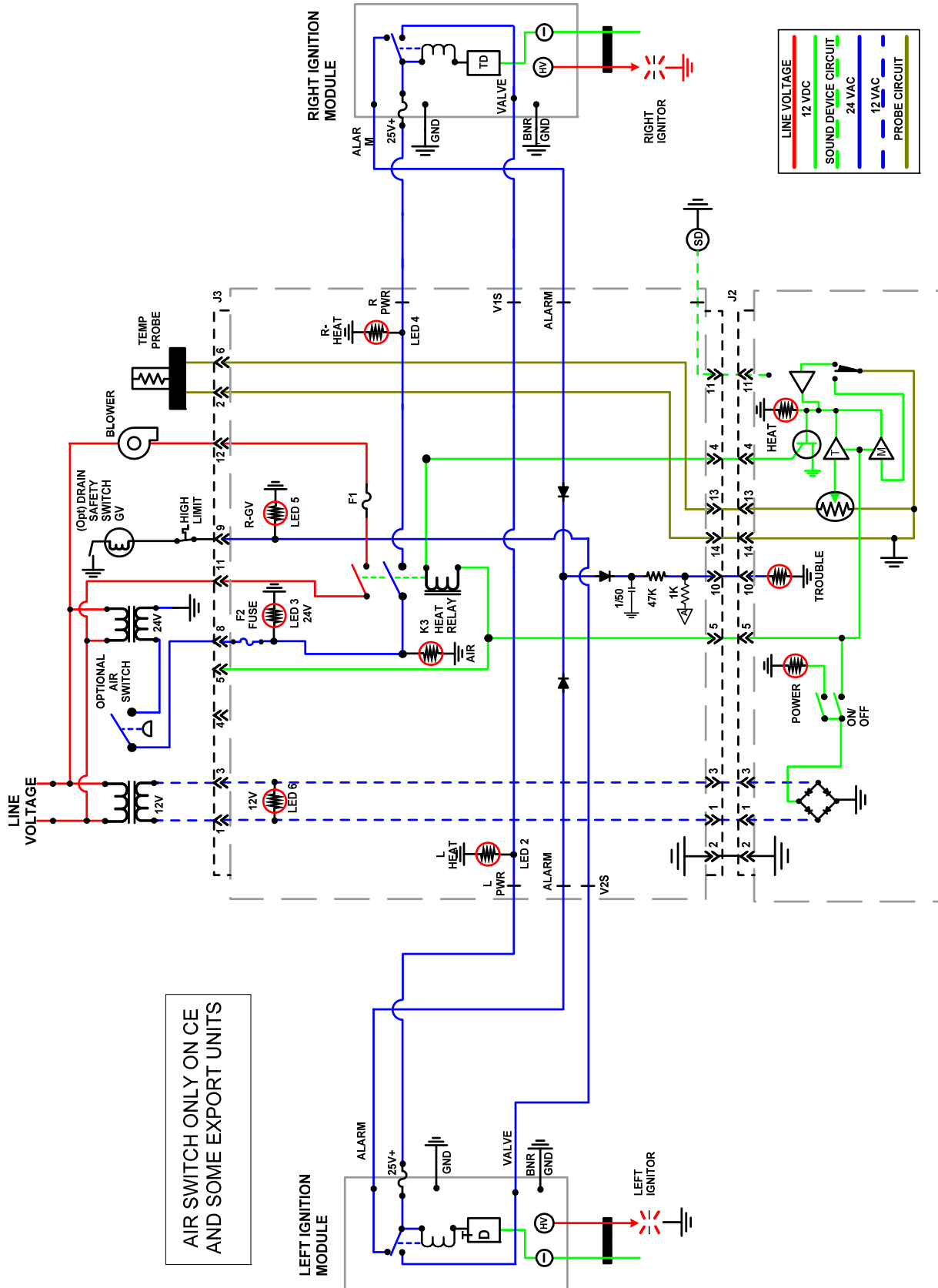



### 1.18.3 FPGL30 Series Dual Vat Single Spark Module excluding Australia

## FPGL30 SERIES – DUAL VAT

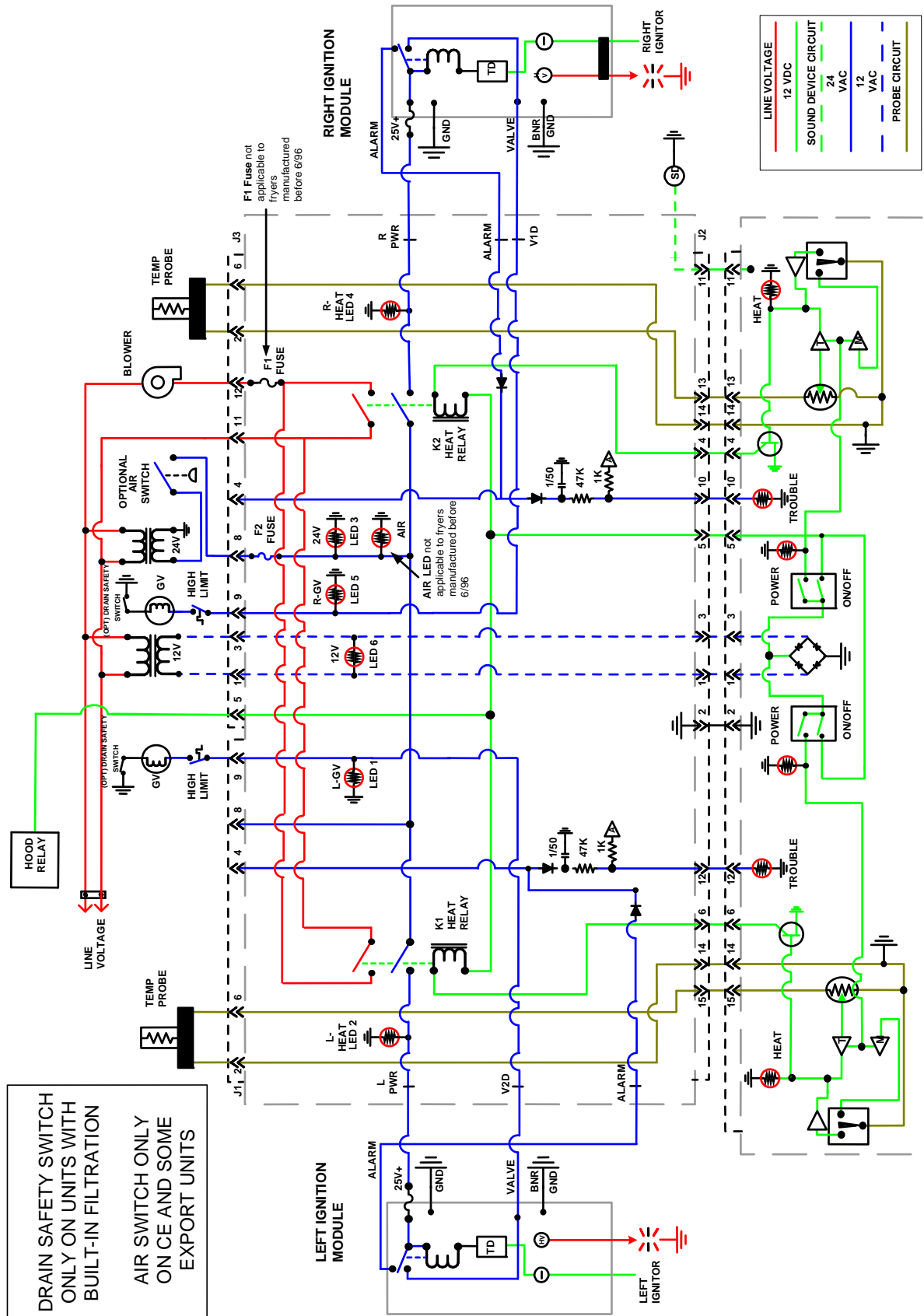

# 1.18.4 FPGL30 Series Simplified Wiring with 3000 Controller

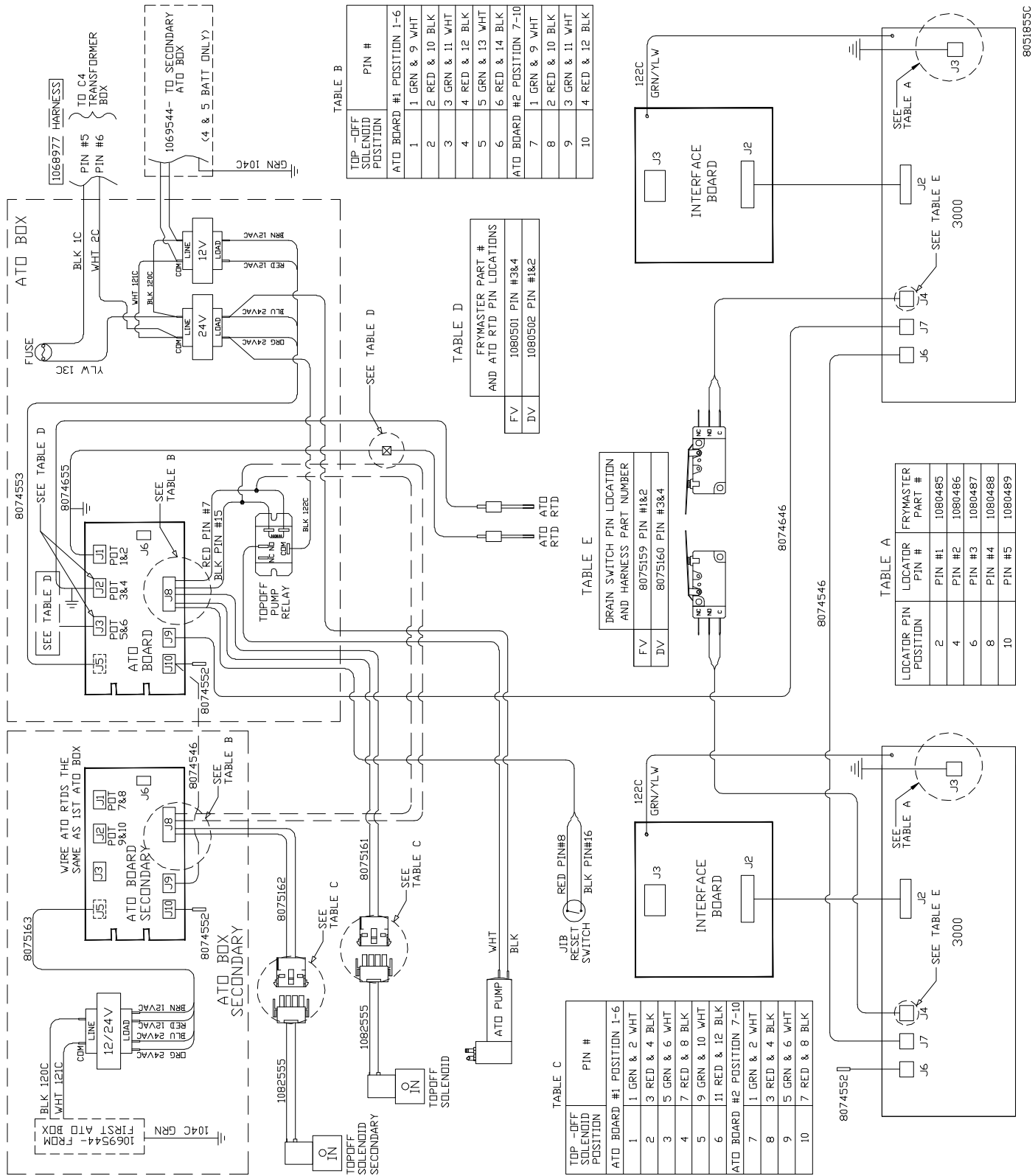

8051855C

### 1.18.5 FPGL30 Series Data Network Flowchart

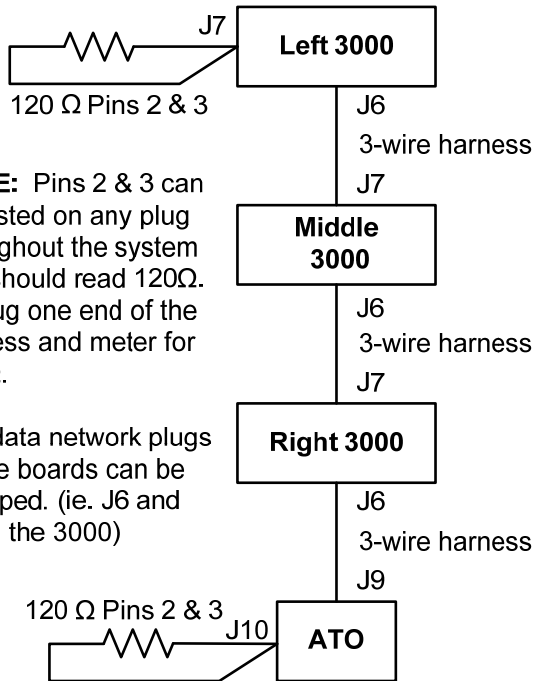

**NOTE:** Pins 2 & 3 can be tested on any plug throughout the system and should read 120Ω. Unplug one end of the harness and meter for 120Ω.

The data network plugs on the boards can be swapped. (ie. J6 and J7 on the 3000)

Harness	Pin #	Function	Voltage	Wire Color
3-wire harness	1	Ground		Black
	2	CAN Lo		Red
	3	CAN Hi		White
	4	NOT USED		
	5			
	6			

**Turn each computer to OFF. Press the TEMP button on each computer and verify ALL software versions are present (3000 and ATO). A missing version may indicate an open connection.**

### 1.18.6 Shortening Melting Unit Wiring Diagram prior to Mar 2012

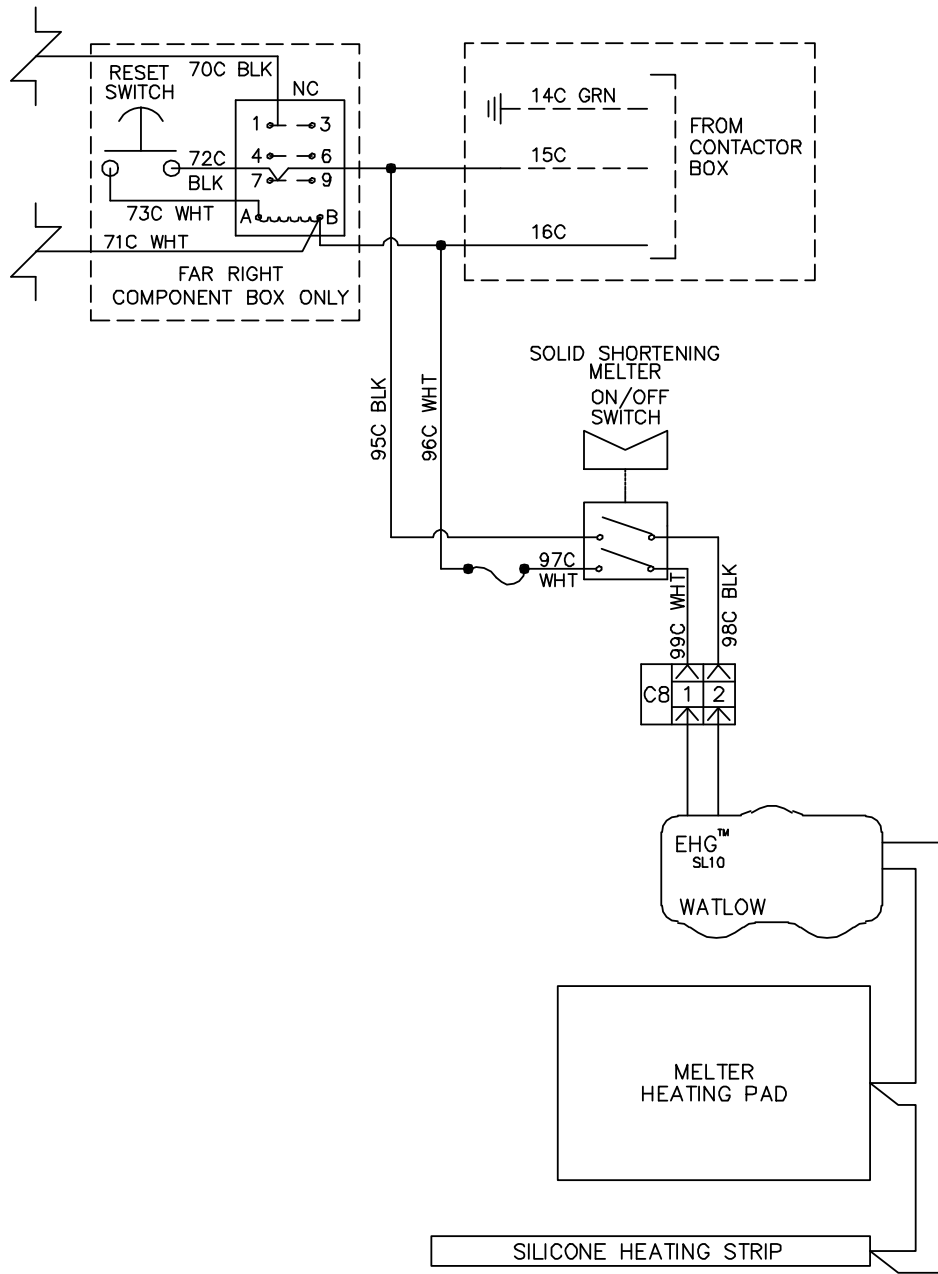

8051889B

### 1.18.6.2 Shortening Melting Unit Wiring Diagram after Mar 2012

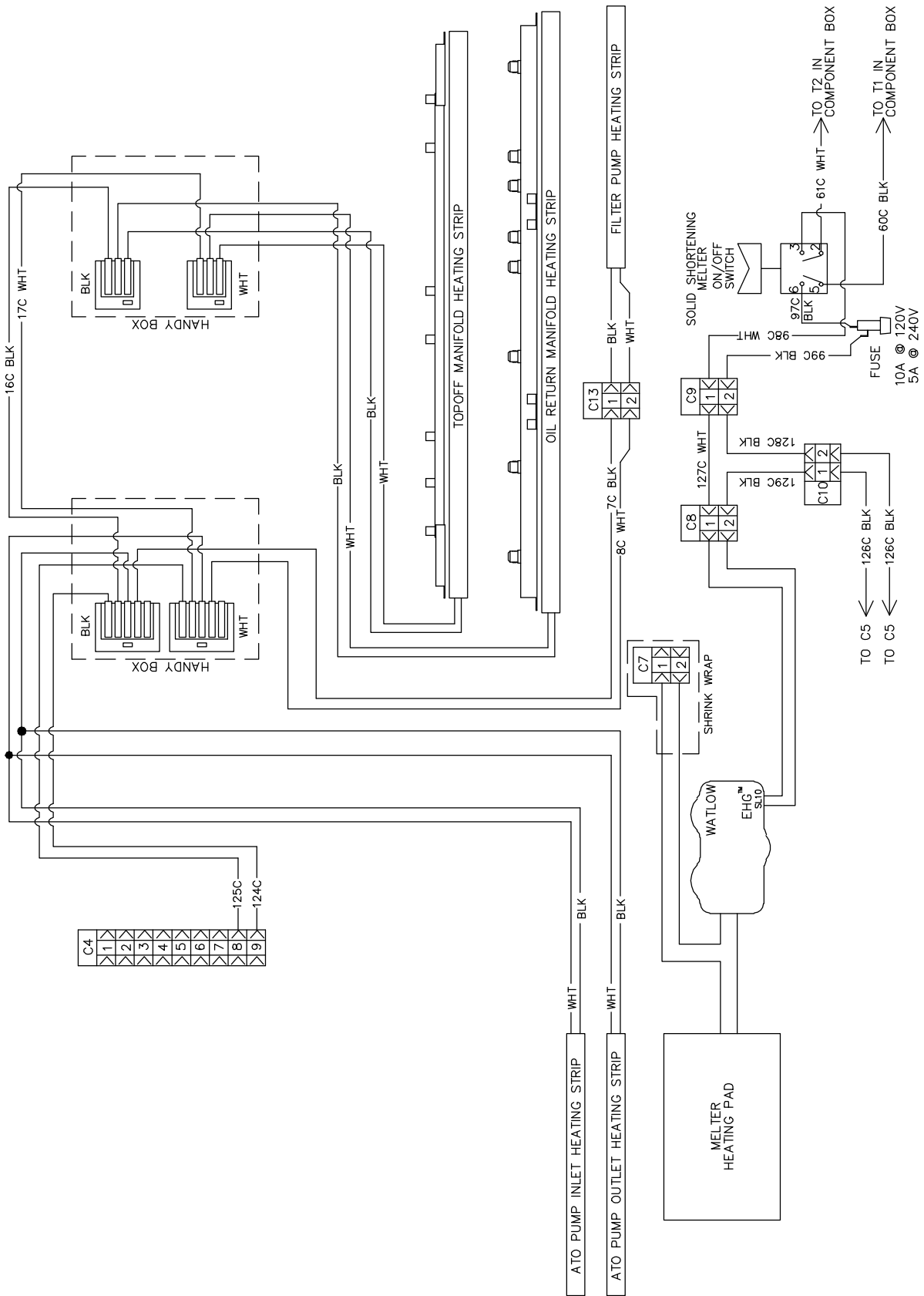

8051923D

# 1.18.7 Bulk Oil Wiring

## 1.18.7.1 FPGL230/430 Wiring 120V, CE and Export Bulk Oil

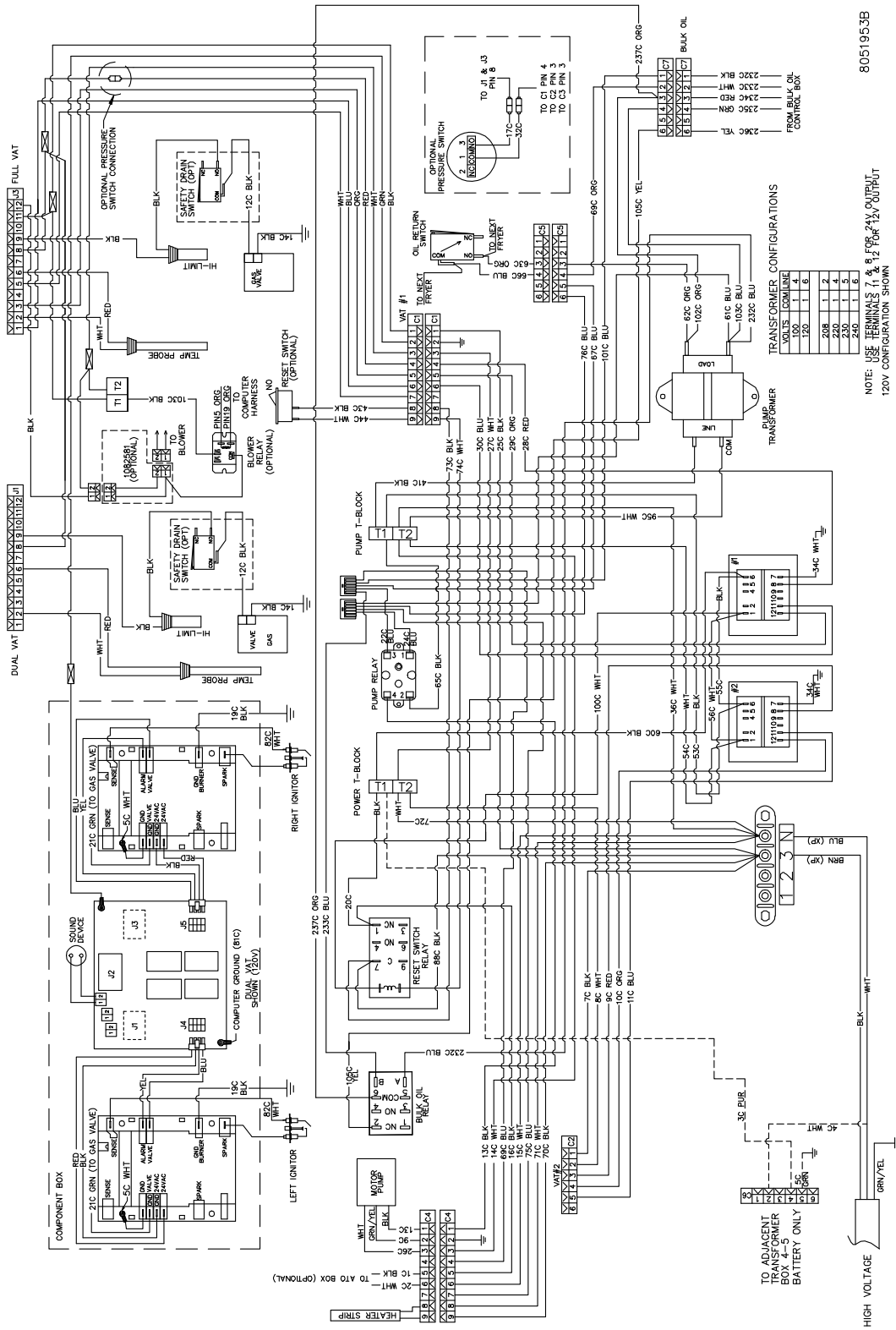

8051953B

1.18.7.2

FPGL230/430 Wiring 250V Australia Bulk Oil

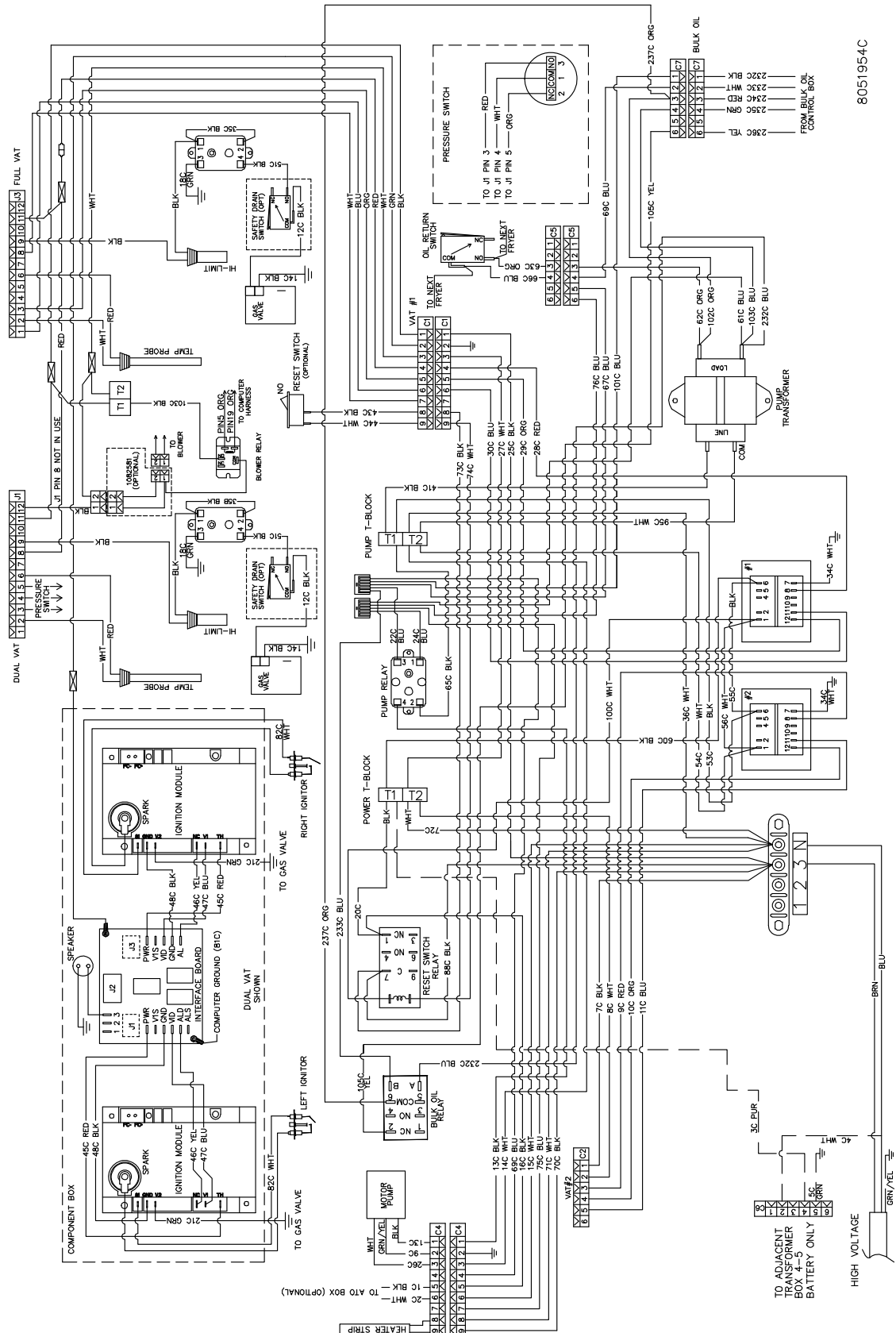

8051954C

# 1.18.7.3 FPGL330 Wiring 120V, CE and Export Bulk Oil

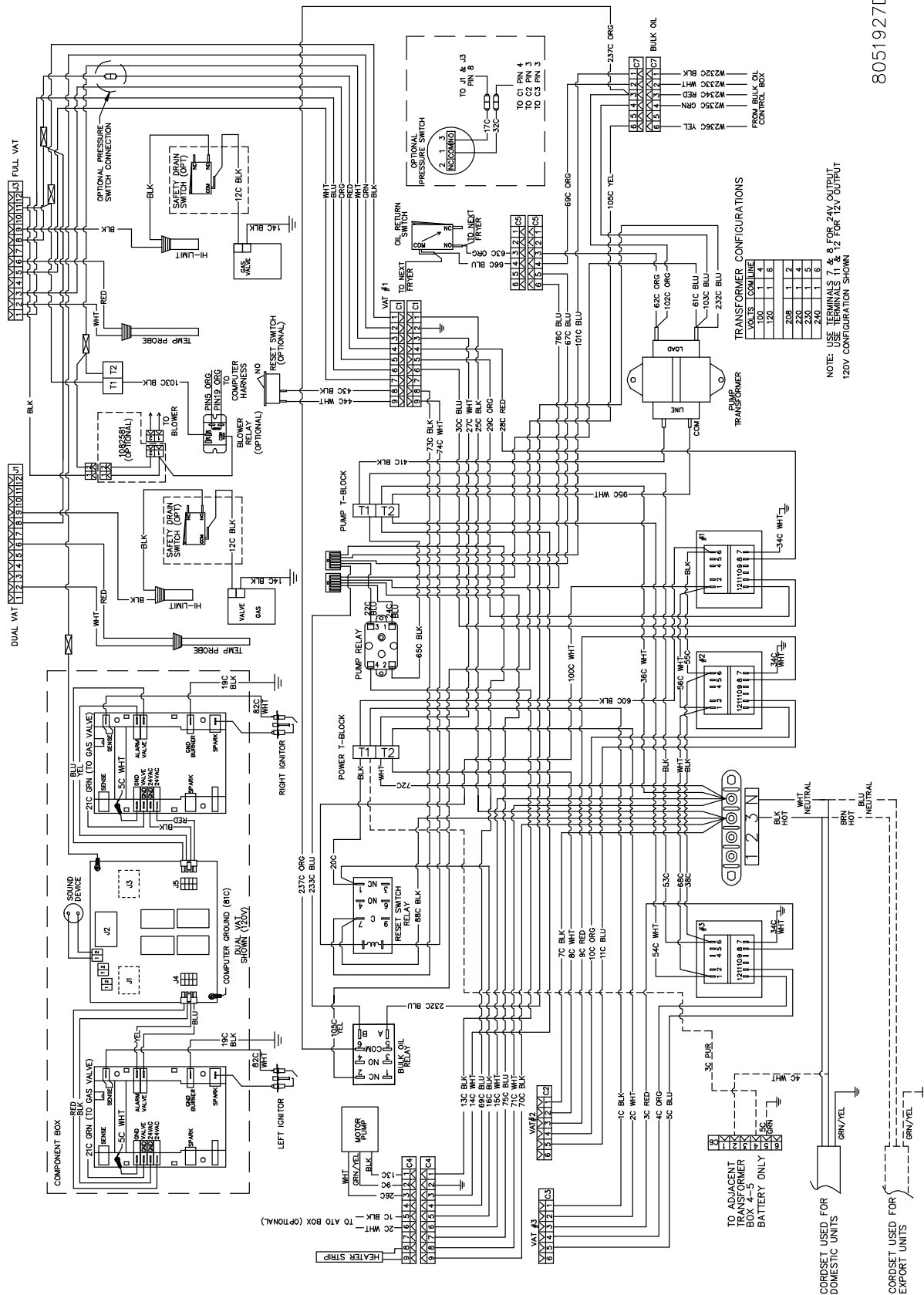

8051927D



# 1.18.7.4 FPGL330 Wiring 250V Australia Bulk Oil

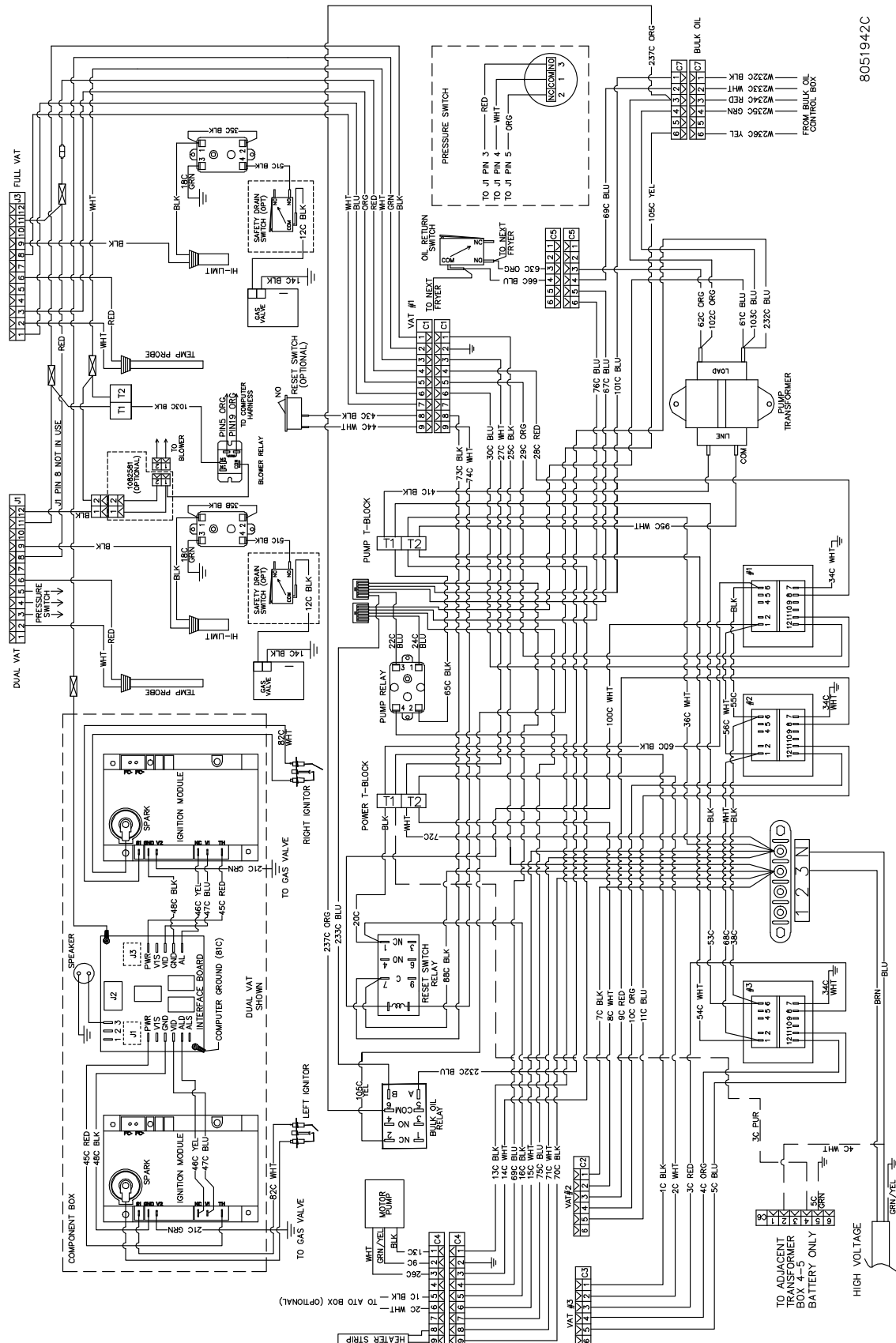

8051942C

# 1.18.8 Bulk Oil Box Wiring

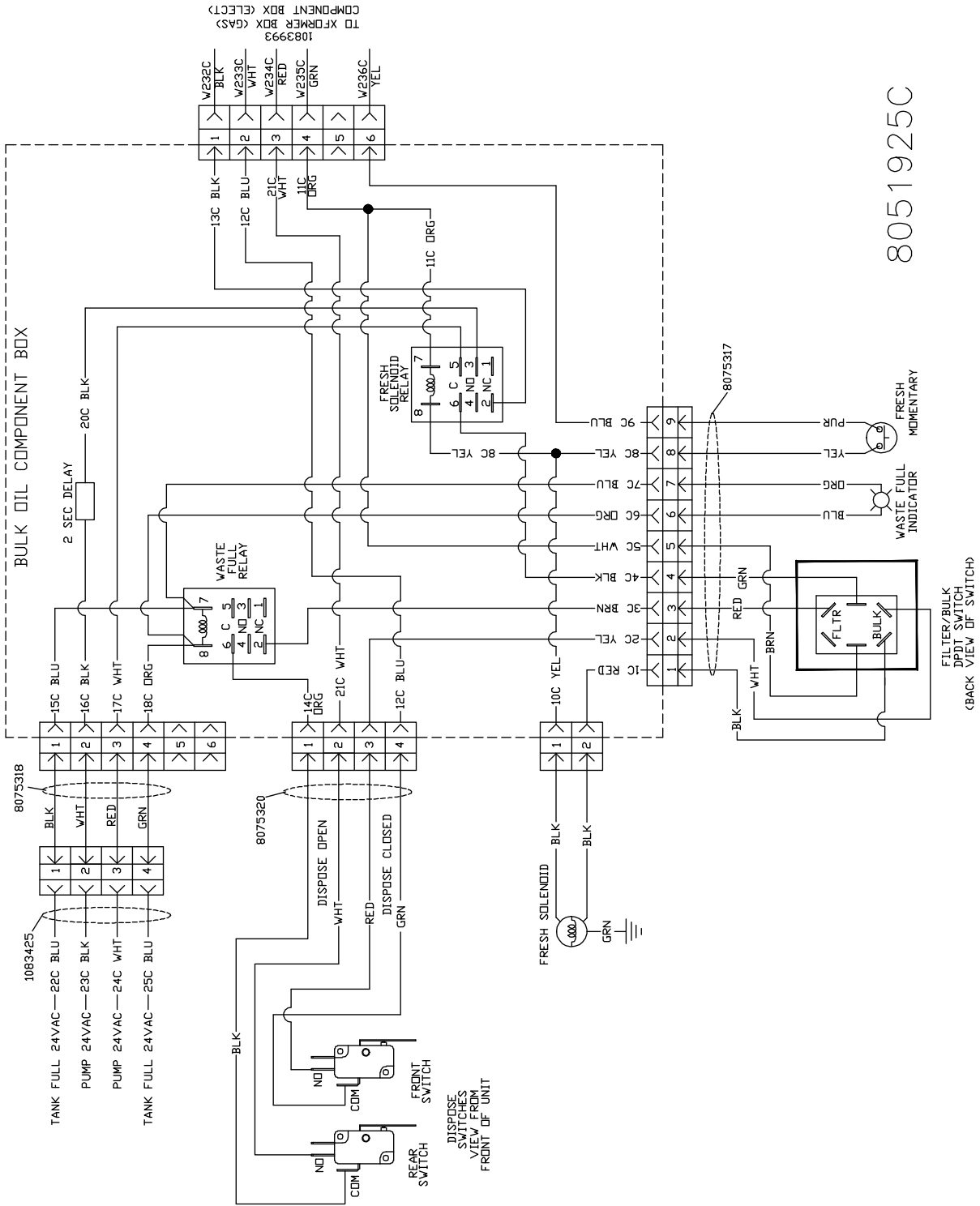

8051925C

# 1.19 Capable Controls Ignition Module Wiring Diagrams

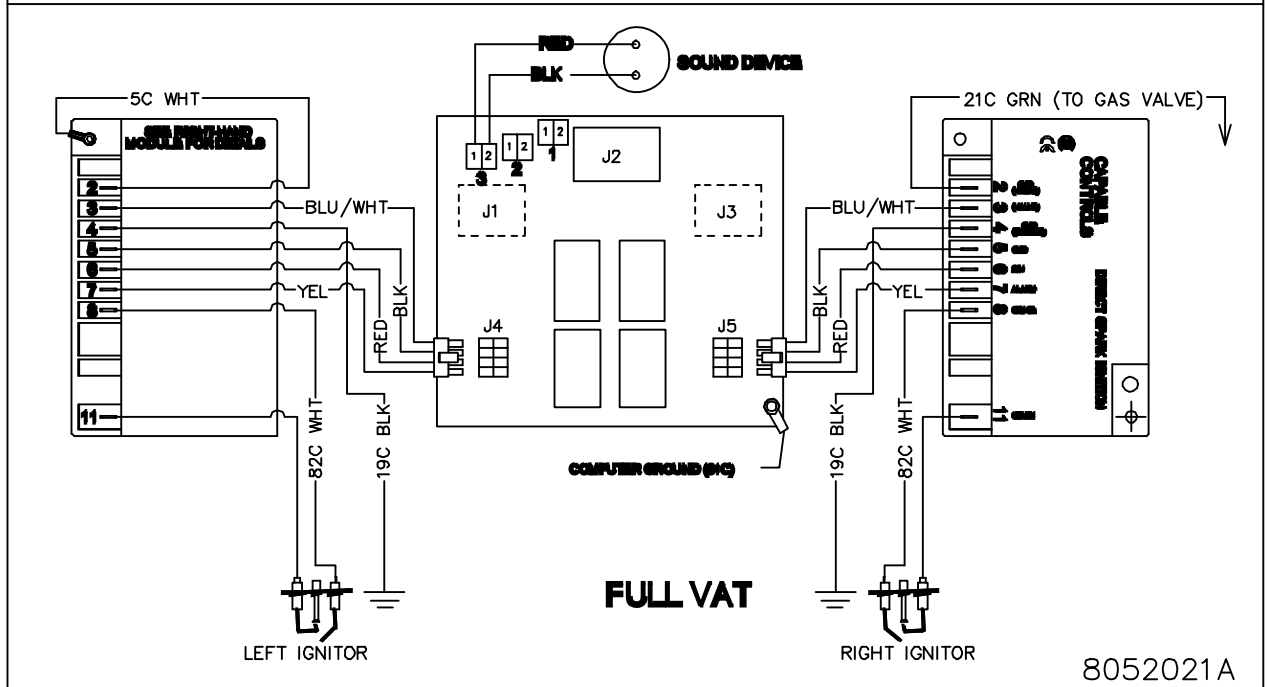
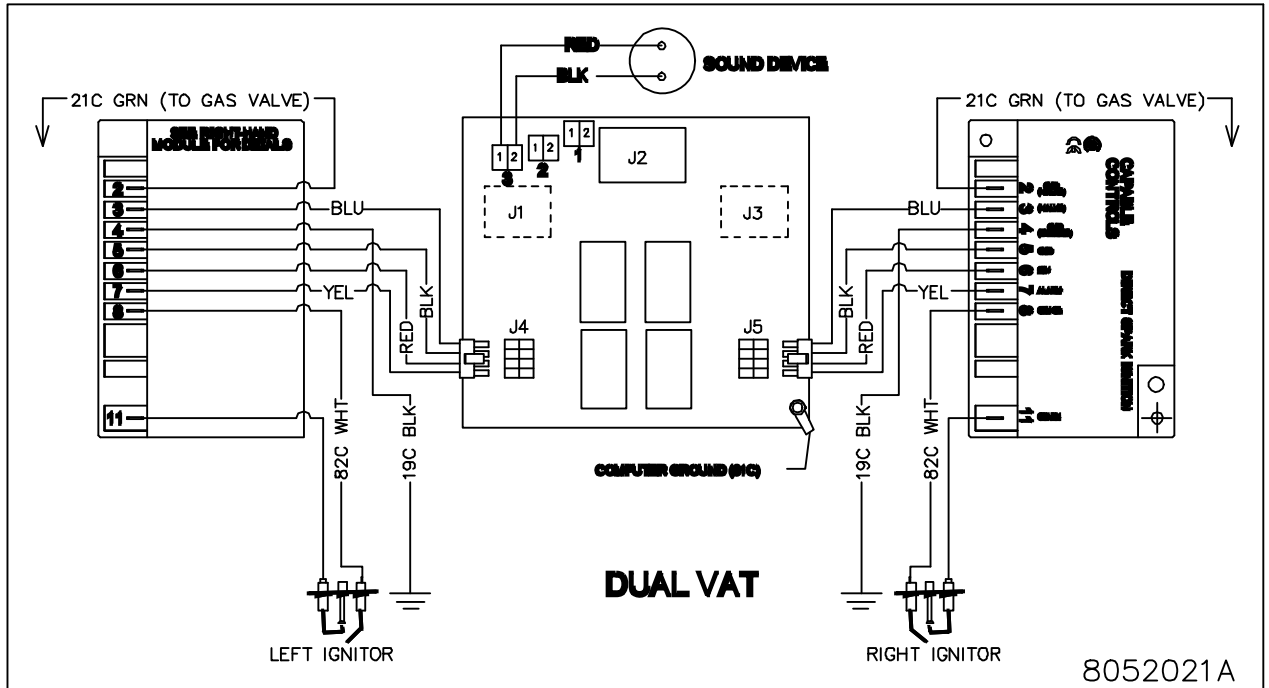

# OCF™ SERIES GAS FRYERS

## CHAPTER 2: PARTS LIST

### 2.1 Accessories

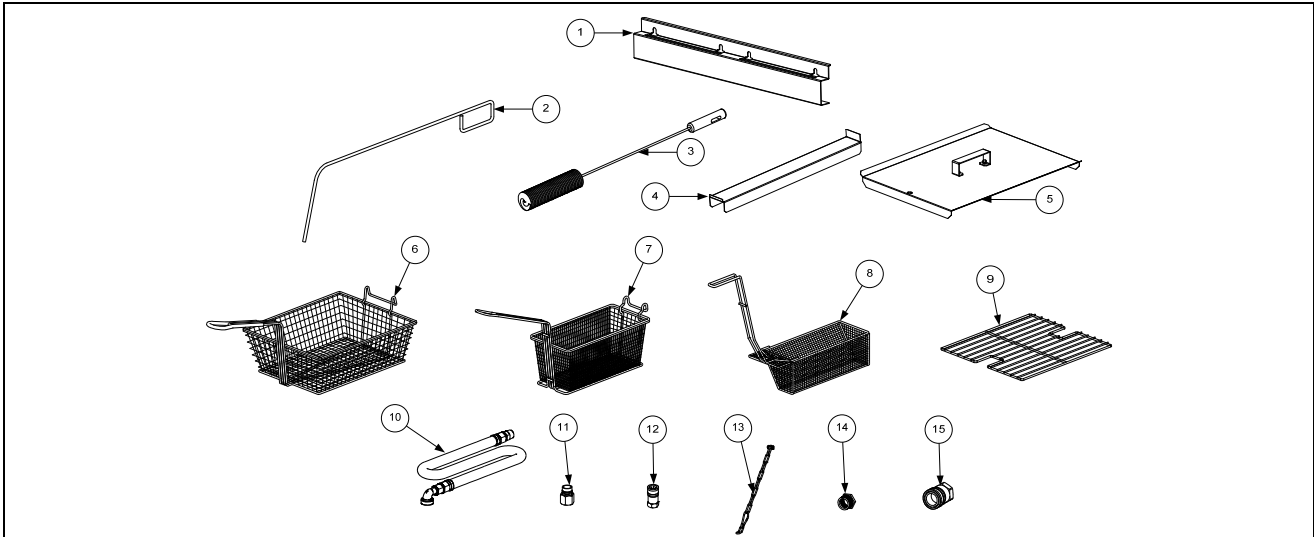

ITEM	PART #	COMPONENT
1	230-8165	Hanger, Basket Single
	230-7495	Hanger, Basket Two Station <i>(use two for a Four Station fryer)</i>
	230-7497	Hanger, Basket Three Station
2	803-0197	Cleanout Rod, 27-inch
3	803-0398	Brush, Frypot
4	230-2975	Connecting Strip, Frypot <i>(230-4677 Spreader Connecting Strip) prior to 07/2014</i>
	108-6156	Connecting Strip, Frypot <i>(108-6168 Spreader Connecting Strip) after 06/2014</i>
5	106-8930	Cover, Full-Vat Frypot <i>(use 106-8931 for Dual-Vat Cover)</i>
*	826-0993SP	Handle Kit, Frypot Cover (includes handle and screws)
6	803-0099	Basket, Full Size
7	803-0271	Basket, Twin Size
8	803-0382	Sediment Tray, Full Vat
9	803-0375	Rack, Full-Vat Basket Support <i>(use 803-0372 for Dual-Vat Basket Support)</i>
10	810-0478	Gas Line, 1-Inch Dormont Flexible
	806-1698SP	36-Inch (for gas line only (w/o Items 11 and 12), use 810-0088)
	806-1699	48-Inch (for gas line only (w/o Items 11 and 12), use 810-0085)
11	810-0074	Quick-Disconnect Fitting, 1-Inch Male
12	810-0073	Quick-Disconnect Fitting, 1-Inch Female
13	826-0900	Kit, Chain Restraint
14	826-1045	Bushing, Flexible Gas Line (813-0032)
15	810-0070	Coupling, Gas Line Female Quick Disconnect ¾-inch
	810-0073	Coupling, Gas Line Female Quick Disconnect 1-inch
*	803-0170	Pack, 100-Sheet Filter Paper 19.5X 27.5
*	803-0002	Powder, Filter (80- 1-Cup Applications)
*	823-8066	Plate, Fish
*	823-8224	Shield, Splash Frypot

\* Not illustrated.

## 2.2 Basket Lift Assy and Associated Parts

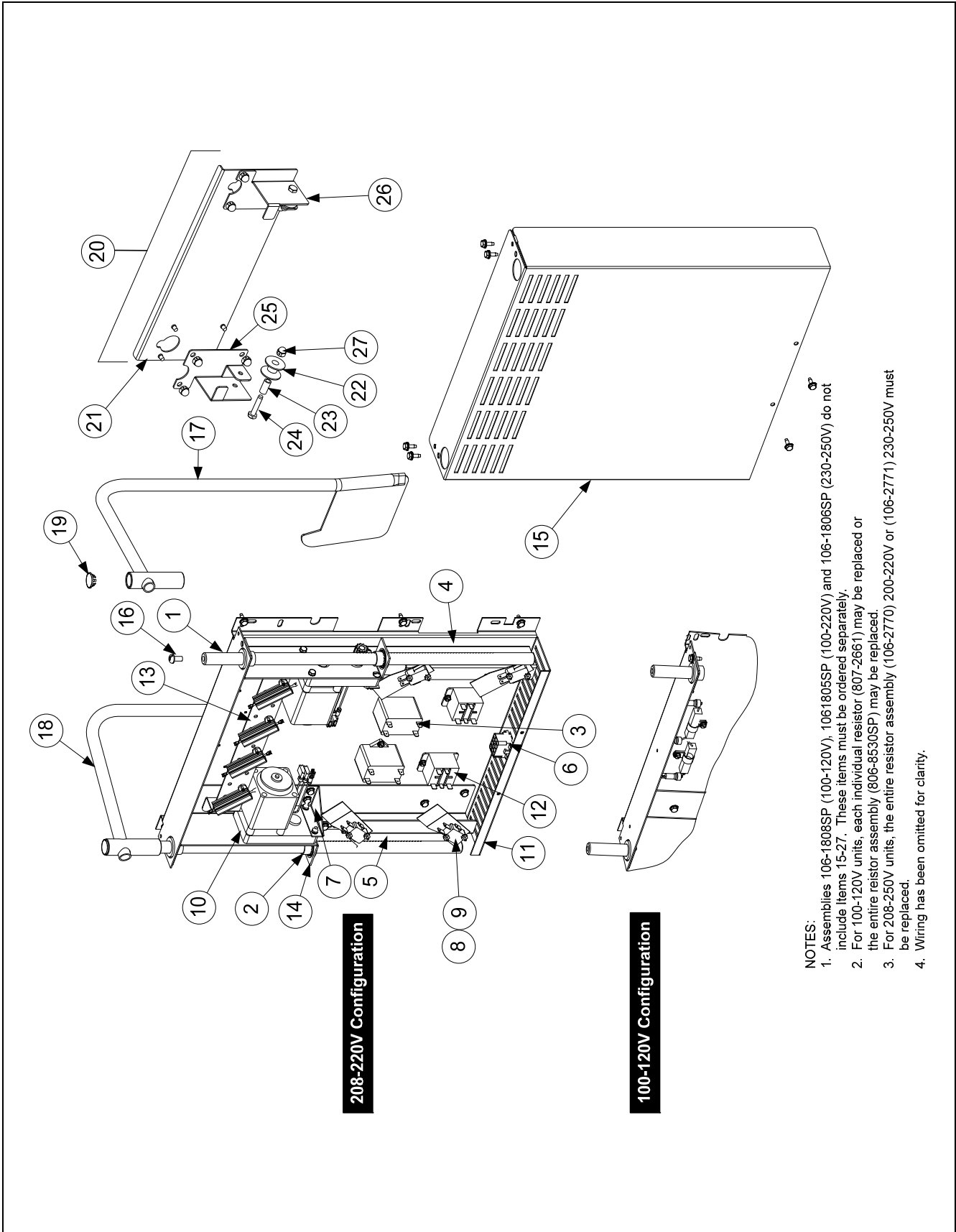

## 2.2 Basket Lift Assy and Associated Parts cont.

ITEM	PART #	COMPONENT
		<b>Basket Lift Assemblies</b> (see <b>Note 1</b> in illustration)
	106-1808SP	Basket Lift Assy, 100-120VAC w/Relay (Items 1-20) shown
	106-1805SP	Basket Lift Assy, 200-220VAC w/Relay (Items 1-20) shown
*	106-1806SP	Basket Lift Assy, 230-250VAC w/Relay (Items 1-20) not shown
1	810-1012	Rod, Basket Lift
2	813-0035	Bushing, Bronze
3	807-2513	Capacitor, 12.5 µFd 330VAC
4	901-8499	Chassis, Left Basket Lift
5	902-8499	Chassis, Right Basket Lift
6	807-0159	Connector, 12-Pin Female
7	900-5529	Gusset, Basket Lift Motor
8	812-0442	Insulation, Microswitch
9	807-2572	Microswitch
10	806-5964SP	Motor Assy, 208-240VAC Modular Basket Lift
11	200-2942	Mount, Modular Basket Lift
12	807-1683	Relay, 12VDC
13		Resistor Assy
	806-8530SP	100-120V Modular Basket Lift (see <b>Note 2</b> in illustration)
	106-2770SP	208-220VAC Modular Basket Lift
*	106-2771SP	230-250VAC Modular Basket Lift
14	809-0082	Ring, Bushing Retainer
15	910-4776	Cover, Modular Basket Lift Rear S/S (Use 900-4776 for Mild Steel)
16	809-0127	Screw, ¼-20 X ½-inch Slotted Round Head
17	823-8015	Arm, Left Basket Lift
18	823-8016	Arm, Right Basket Lift
19	810-0179	Button, Plug
20	108-2743SP	Roller Assy, Basket Lift
21	108-2860	Mount, Basket Lift Roller
22	810-0194	Roller, Basket Lift
23	810-0374	Spacer, Basket Lift Roller
24	809-0508	Bolt, ¼-20 X 1¼ -Inch
25	823-7980	Guide, Basket lift Left
26	823-8023	Guide, Basket lift Right
27	809-0990	Nut, ¼-20 Cap
*	824-1477	Tray, Drip Right
*	824-1476	Tray, Drip Left
		<b>Wire Assemblies</b>
*	108-3454	Harness, Gas OCF BL Interface
*	807-3695	Basket Lift Cable
*	WIR-0166SP	Wire Bundle, 200-250VAC Basket Lift w/Relay
*	106-1822SP	For 100-120V Modular Basket Lift
*	106-1804SP	For 208-250V Modular Basket Lift

\* Not illustrated.

### 2.3 Doors, Sides, Flue Caps, Top Caps and Casters

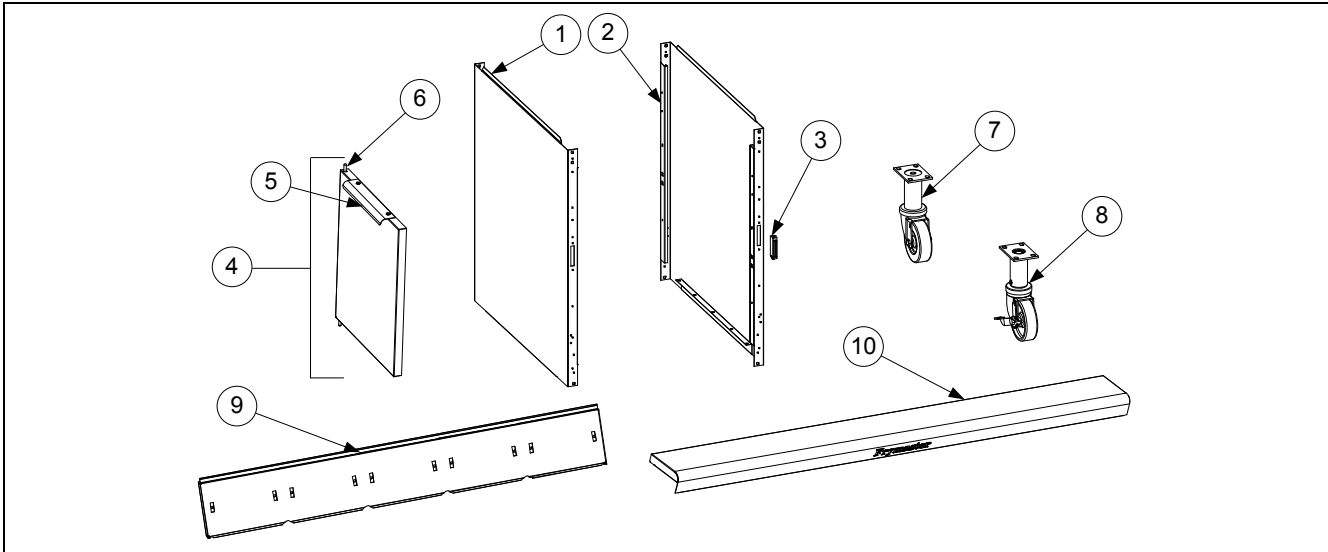

ITEM	PART #	COMPONENT
1	231-7908	Side, Standard Cabinet Left SS
2	232-7908	Side, Standard Cabinet Right SS
3	810-1105	Magnet, Door (vertical) (use 810-2346 for horizontal over filter pan)
4	106-4397	Door, Left or Right (Left shown – move handle to bottom for right)
5	230-4960	Handle, Eurolook Door
6	106-4067	Pin Assy, Door
*	810-0275	Spring, Door Pin
*	809-0970	Retaining Ring
*	230-7192	Hinge, Door Lower
*	210-8288	Panel, Universal Door
*	220-6097	Holder, Manual
7	810-0327	Caster 4" without Brake
8	810-0944	Caster 3" with Brake
9		Flue Cap-Stainless Steel
	823-7962	Single Station Fryer <i>prior to 07/2014</i>
	823-8969	Single Station Fryer <i>after 06/2014</i>
	823-7724	Two Station Fryer <i>prior to 07/2014</i>
	823-8922	Two Station Fryer <i>after 06/2014</i>
	823-7727	Three Station Fryer <i>prior to 07/2014</i>
	823-8923	Three Station Fryer <i>after 06/2014</i>
	823-7728	Four Station Fryer <i>prior to 07/2014</i>
	823-8924	Four Station Fryer <i>after 06/2014</i>
	823-7752	Five Station Fryer <i>prior to 07/2014</i>
	823-8925	Five Station Fryer <i>after 06/2014</i>
10		Top Cap
	108-2691	Single Station Fryer <i>prior to 07/2014</i>
	108-6171	Single Station Fryer <i>after 06/2014</i>
	108-1522	Two Station Fryer <i>prior to 07/2014</i>
	108-6158	Two Station Fryer <i>after 06/2014</i>
	108-1523	Three Station Fryer <i>prior to 07/2014</i>
	108-6159	Three Station Fryer <i>after 06/2014</i>
	108-1524	Four Station Fryer <i>prior to 07/2014</i>
	108-6160	Four Station Fryer <i>after 06/2014</i>
	108-3030	Five Station Fryer <i>prior to 07/2014</i>
	108-6161	Five Station Fryer <i>after 06/2014</i>

\* Not illustrated.

## 2.4 Drain System Components

### 2.4.1 Drain Valves and Associated Parts

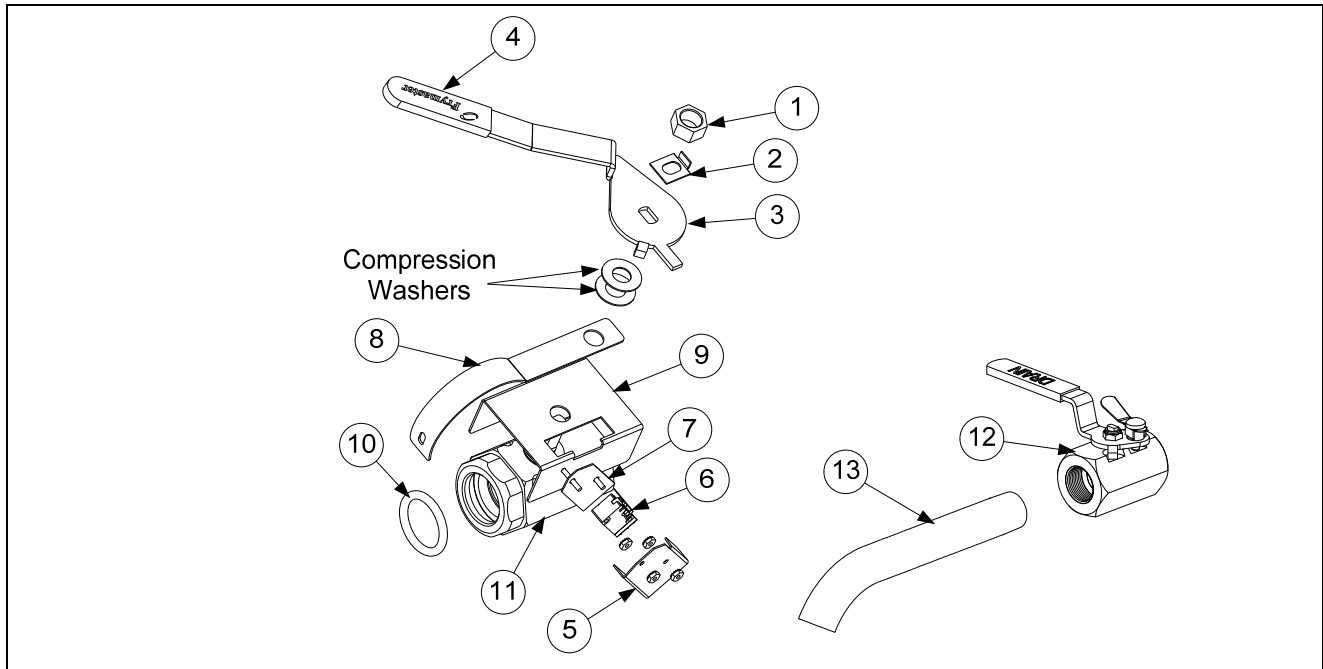

ITEM	PART #	COMPONENT
	108-2509	Valve, Assy Drain FV/DV Left with Filter and Auto Top Off ( <i>use 108-2510 for Right</i> )
	108-2507	Valve, Assy Drain DV Left with Filter ( No Top Off) ( <i>use 108-2508 for Right</i> )
	108-2593	Valve, Assy Drain FV Single with Filter (No Top Off)
	108-2449	Valve, Assy Drain DV Left Single with Filter (No Top Off) ( <i>use 108-2450 for Right</i> )
1	809-0540	Nut, ½-13 2-Way Hex Lock
2	900-2936	Retainer, Nut Drain Valve
3	230-8556	Handle, Drain Valve FV with Filter
	230-8557	Handle, Drain Valve DV Left with Filter ( <i>use 230-8558 for Right</i> )
	824-2188	Handle, Drain Valve Long FV Single and DV Left with Filter & auto top off
	824-2189	Handle, Drain Valve Long DV Single Right and DV Left With Filter
4	814-0047	Cap, Vinyl Red
5	901-2348	Cover, Safety Switch
6	807-4936	Switch, Micro Gold Plated
7	816-0220	Insulation, RF Switch
8	200-6496	Support, Drain Tube
9	108-2506	Bracket Assy, Drain Switch FV and DV Left
	108-2537	Bracket Assy, Drain Switch DV Right
	220-8162	Bracket, Single 1¼-inch Drain Valve (used on FV Single with Filter)
10	816-0135	O-Ring, Round Drain Seal
11	810-1018	Valve, 1¼-inch Drain with Filter
12	810-1569	Valve, 1¼-inch Drain Non-Filter
13	812-1226	Drain Extension 1¼-inch ( <i>use with 810-1569</i> )
*	807-5159	Harness, Drain FV ( <i>connects from drain switch to rear of 3000 controller only</i> )
*	807-5160	Harness, Drain DV ( <i>connects from drain switch to rear of 3000 controller only</i> )



## 2.4.2 Drain Tube Sections and Associated Parts

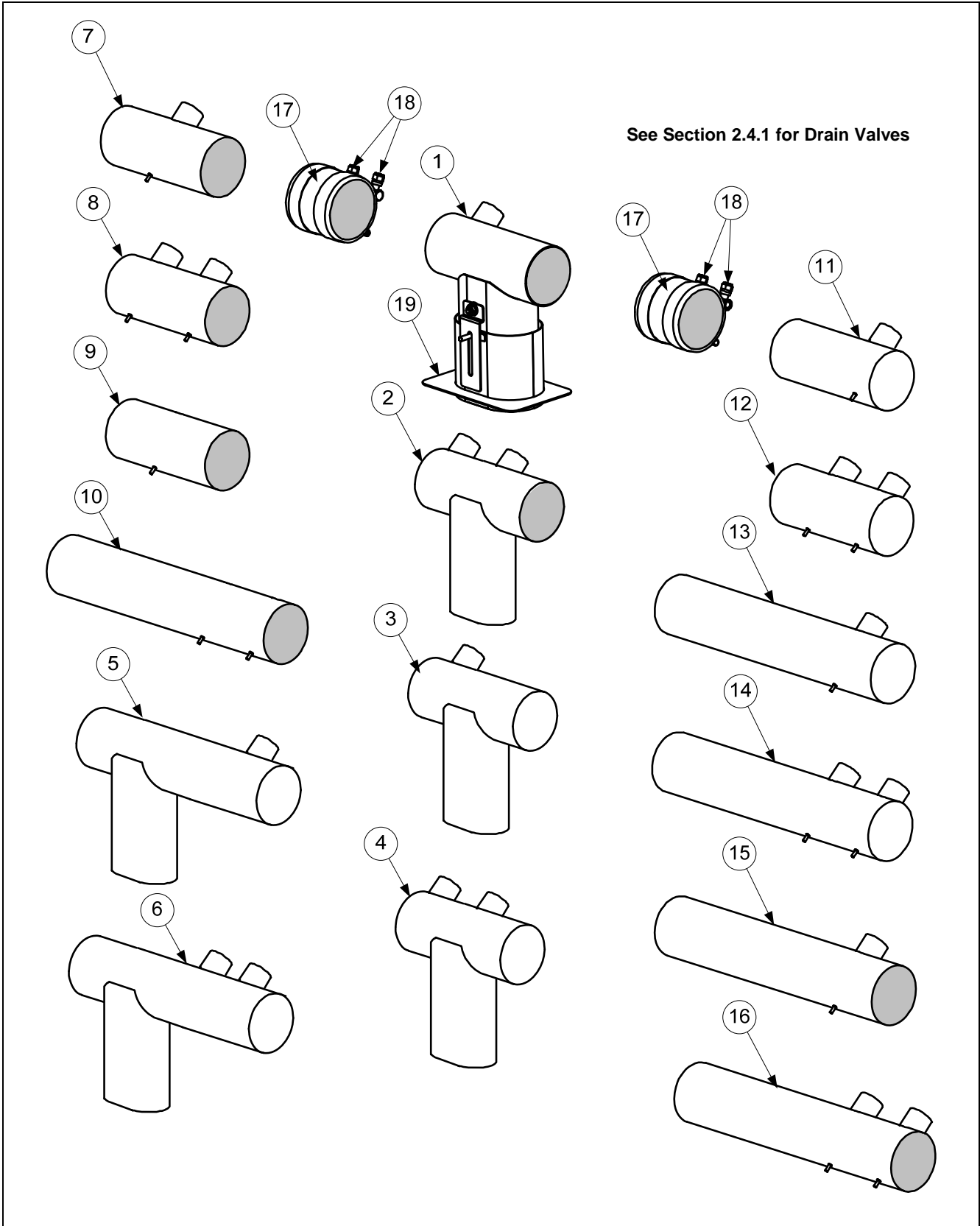

## 2.4.2 Drain Tube Sections and Associated Parts cont.

ITEM	PART#	COMPONENT
1	823-8135	Drain Tube, Dump Full-Vat Left Closed/Right End Open
2	823-8136	Drain Tube, Dump Dual-Vat Left Closed/Right End Open
3	823-8137	Drain Tube, Dump Full-Vat Left Closed Both Ends
	823-7959	Drain Tube, Dump Single Full-Vat Left Closed Both Ends
4	823-8138	Drain Tube, Dump Dual-Vat Left Closed Both Ends
	823-7946	Drain Tube, Dump Single Dual-Vat Left Closed Both Ends
5	823-8139	Drain Tube, Dump Full-Vat Left Closed Both Ends
*	823-8130	Drain Tube, Dump Full-Vat Left Closed/Right End Open
6	823-7943	Drain Tube, Dump Dual-Vat Left Closed Both Ends
*	823-8131	Drain Tube, Dump Dual-Vat Left Closed/Right End Open
7	823-4643	Drain Tube, Full-Vat, Short, Open Both Ends
8	823-7905	Drain Tube, Dual-Vat, Short, Open Both Ends
9	810-3550	Drain Tube, Short, Open Both Ends
10	810-3551	Drain Tube, Long, Open Both Ends
11	823-4625	Drain Tube, Short Full-Vat Left Open/Right End Closed
12	823-7906	Drain Tube, Short Dual-Vat Left Open/Right End Closed
13	823-4639	Drain Tube, Long Full-Vat Left Open/Right End Closed
14	823-7908	Drain Tube, Long Dual-Vat Left Open/Right End Closed
15	823-4641	Drain Tube, Long Full-Vat Open Both Ends
16	823-7907	Drain Tube, Long Dual-Vat Open Both Ends
17	816-0772	Sleeve
18	809-0969	Clamp
*	816-0630	Vinyl Cap
*	811-1071	Tubing, ¼-inch OD Teflon Vent (sold by the foot)
19	823-7915	Guard, Filter Lid Splash

\* Not illustrated.

## 2.5 Electronics and Electrical Components

### 2.5.1 Controllers and Associated Components

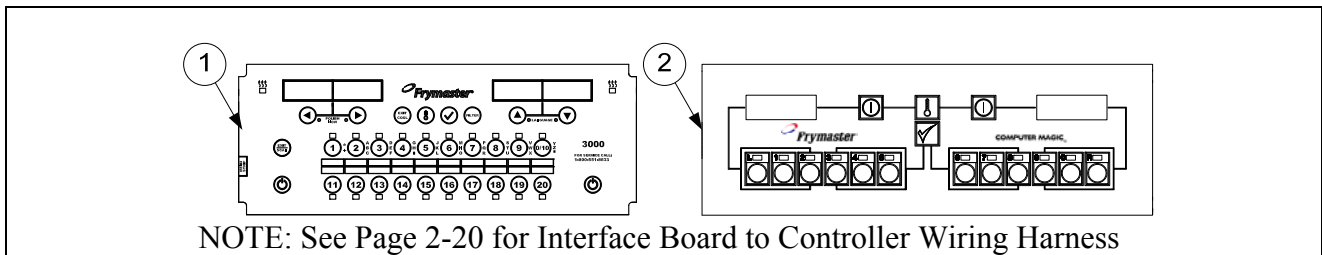

ITEM	PART #	COMPONENT
√ 1	826-3107	Replacement 3000 Controller
√ 2		Replacement CM 3.5 Controller
	826-2380	Non-CE CM3.5 ( <i>For use in US, Canada, Mexico and all other non-CE countries</i> )
	826-2381	CE CM3.5 ( <i>For use in European CE countries</i> )
	826-2382	CE CM3.5 ( <i>For use in non-CE countries with 8 sec. melt cycle</i> )
	810-3141	Sound Device, Universal SMT

√ Recommended parts.

## 2.5.2 Component Boxes

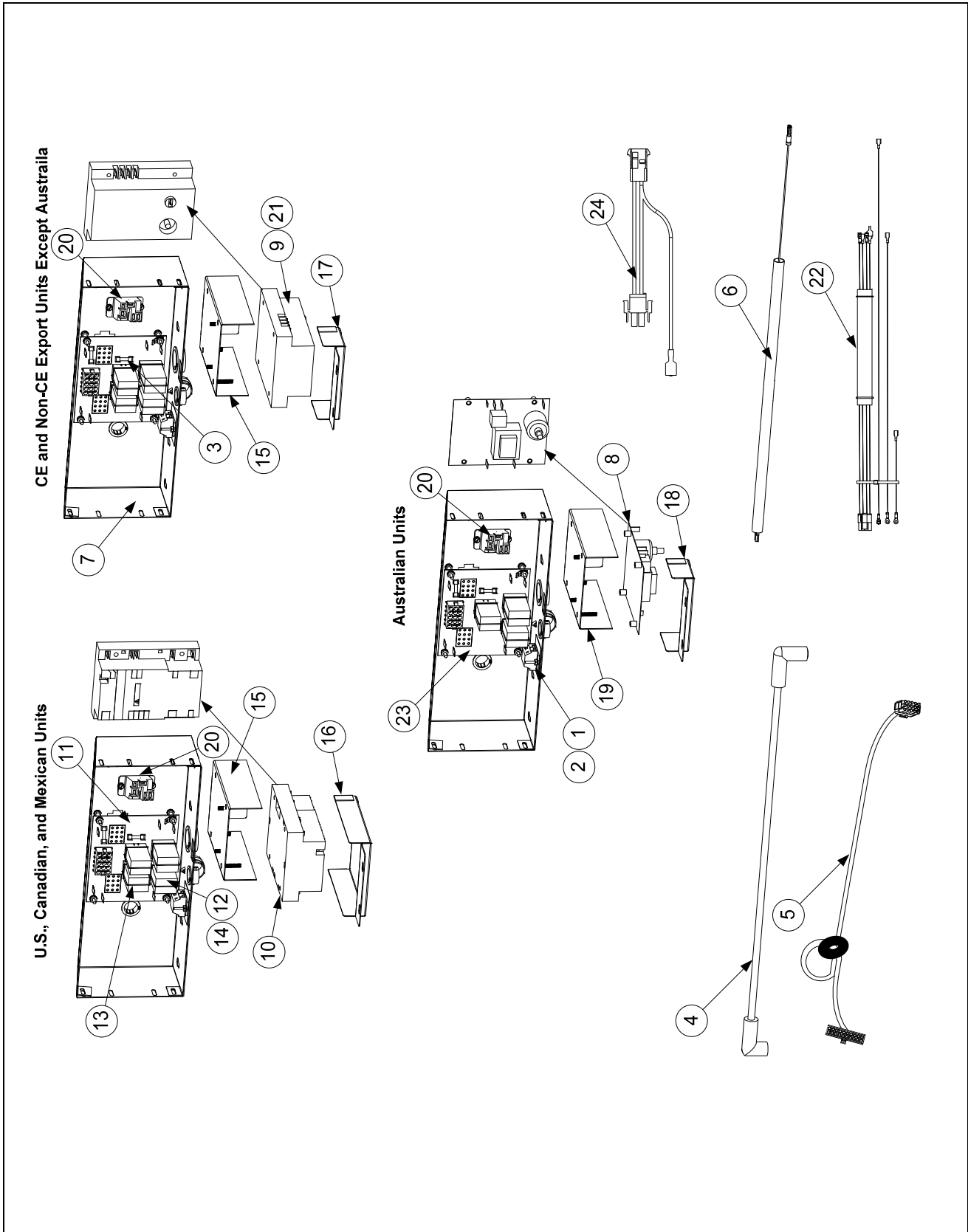

## 2.5.2 Component Boxes cont.

ITEM	PART #	COMPONENT
1	810-1164	Block, One-Piece Screwless Terminal
2	816-0217	Insulation, Terminal Block Paper
√ 3	807-3843	Fuse 3A 250V Domestic
√ *	826-1157	Kit, Fuse and Fuse Puller (2 Fuses)
	807-3293	Fuse 5A 125V <b>International Only</b>
*	106-0531SP	Fuse Assy, Inline
√ 4	807-5008	Cable, 21-inch Ignition – For 807-3366/807-3365 Modules
*	807-5009	Cable, Ignition 19" (CE)
*	807-3484	Connector, Rajah
5	807-4199	Cable, 20-pin Controller to 15-pin Interface Board – SMT for fryers with CM 3.5 controller.
*	807-5165	Cable, 20-pin Controller to 15-pin Interface Board – SMT for fryers with 3000 controller.
6	806-6085SP	Wire Assembly, Ignitor
7	220-6102	Box, One-Piece Component
√ 8	807-2971	Ignition Module, (Australia)
√ 9	807-1006	Ignition Module, CE
√ 10	8073366†	Ignition Module, Honeywell Dual-Spark Full-Vat ( <i>Domestic and Non-CE export unit except Australia</i> )
√	8073365†	Ignition Module, Honeywell Single-Spark Dual-Vat ( <i>Domestic and Non-CE export unit except Australia</i> )
√	8075949	Ignition Module, Fenwal Single-Spark Full/Dual-Vat ( <i>Domestic and Non-CE export unit except Australia</i> ) ( <b>Use 8263446 for a Conversion Kit – NOTE: 2 kits are needed to convert a Full Vat.</b> )
√ 11	826-2264	Interface Board Kit SMT
	807-4330	Speaker Adapter Harness SMT
	807-4343	Wire Harness, SMT Interface Board to Ignition Module
√ 12	807-0833	Relay, DPDT 5A 12VDC Latch (See <b>NOTE 1.</b> )
√ 13	807-0834	Relay, SPDT 15A 12VDC Basket Lift (See <b>NOTE 2.</b> )
14	810-2243	Spring, Relay Retaining
15	108-1094	Plate, Ignition Module
16	824-2090	Cover, Ignition Module
17	824-2091	Cover, Ignition Module CE
18	220-7085	Cover, Ignition Module Australia
19	108-1544	Plate, Ignition Module Australia
20	807-1683	Relay, 12VDC Secondary Blower Fan to cool frypot
21	106-0531SP	Fuse Assembly, Inline ( <i>not used on all models</i> )
*	807-2659	Switch, Momentary ( <i>Control Power Reset, only used in far left component box</i> )
*	807-4403	Speaker SMT
22	108-1260	Wire Assembly, Ignition Module Domestic and Non-CE export, except Australia.
	108-2353	Wire Assembly, Ignition Module CE
23	806-4973	Interface Board, Australia
24	108-2581	Harness, Secondary Blower

\* Not illustrated.

√ Recommended parts.

† For Full-vat units, use one 807-3366 Dual Spark Ignition Module (see NOTE 1).

† For Dual-vat units, use two 807-3365 Single Spark Ignition Modules (see NOTE 1).

**NOTE 1:** U.S., Canadian, and Mexican units use two different modules depending upon the configuration of the frypot. Full-Vat units use one 807-3366 Dual-Spark Ignition Module while Dual-Vat units use two 807-3365 Single-Spark Ignition Modules. Also, in full-vat units, only two latch relays (Item 12) are used, located in the sockets on the right side of the interface board. These relays are located in the bottom sockets of the interface board and control the heating circuit.

**NOTE 2:** The relays in the top sockets control the basket lifts (Item 13) and are present only on units equipped with basket lifts.

### 2.5.3 Transformer Boxes

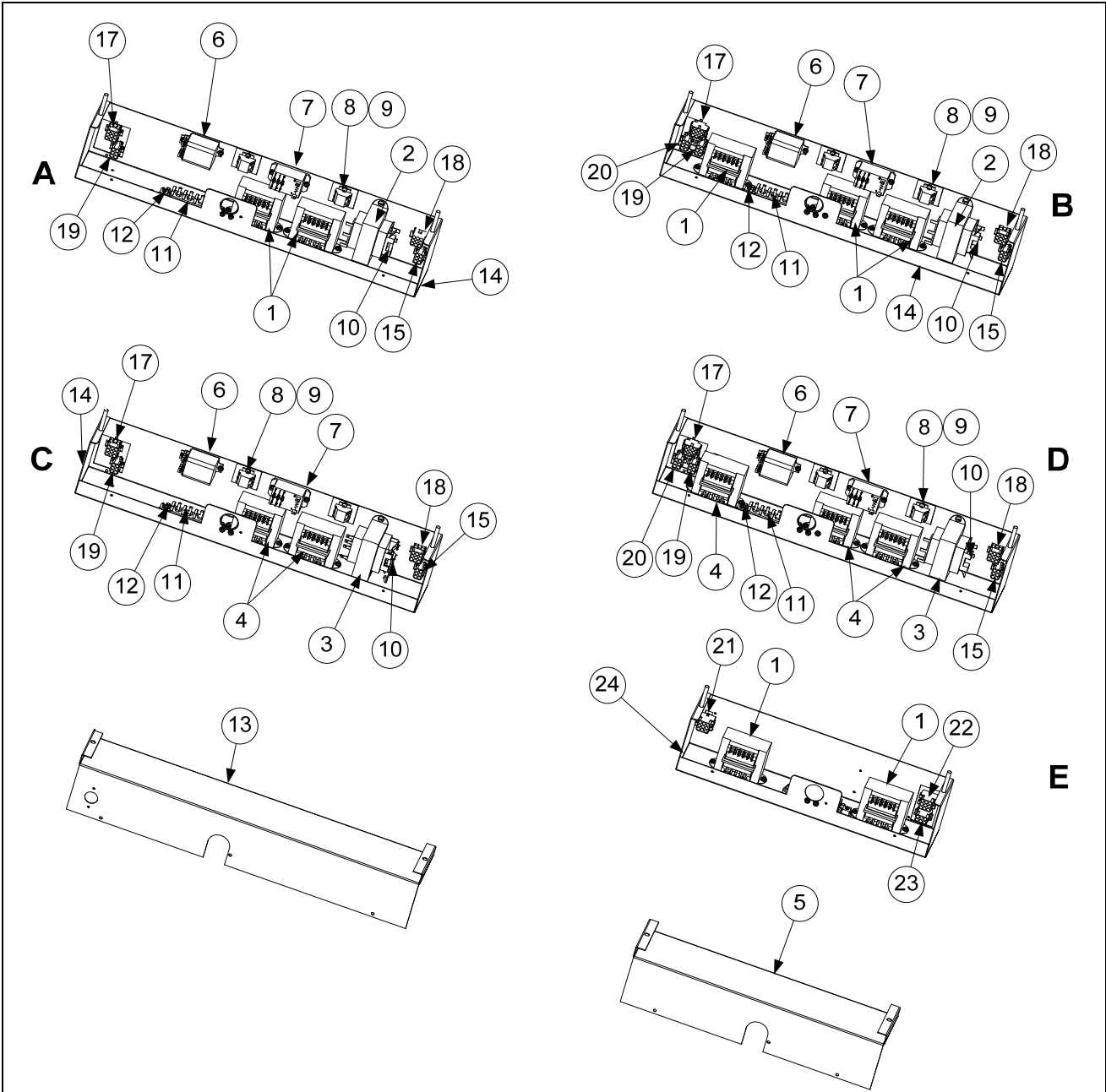

ITEM	PART #	COMPONENT
		Box Assembly, Transformer
A	106-9021	GL230 and 430 (430 has added cordset 108-1769)
B	106-9022SP	GL330
C	108-1765	GL230 and 430 CE and Export (430 has added cordset 108-1770)
D	108-1764	GL330 CE and Export
E	108-1768	GL430 CE and Export
√ 1	807-2176	Transformer, 100-120V V/F Dual Voltage
√ 2	807-0800	Transformer, 100-120V/24V 50VA Filter and MIB
√ 3	807-2180	Transformer, 208-240V/24V 50VA Filter and MIB
√ 4	807-5129	Transformer, V&F Dual Voltage 208/222/230/240V
5	220-6514	Cover, GL30 Small Transformer Box

√ Recommended parts.

### 2.5.3 Transformer Boxes cont.

ITEM	PART #	COMPONENT
√ 6	807-4346	Relay, DPDT 20A 120VAC (Control Reset Button) <i>(used for control power reset in domestic units)</i>
√	807-4770	Relay, DPDT 20A 240V <i>(used for control power reset in international units)</i>
√ 7	807-0012	Relay, Filter 18A 24VAC
8	816-0217	Insulation, Terminal Block Paper
9	810-1164	Block, One-Piece Screwless Terminal
√ 10	807-1597	Fuse, 3amp Slo-Blow
11	807-1973	Terminal, Post
12	807-0070	Terminal, Ground Lug
13	220-3191	Cover, Large Transformer Box
14	823-6324	Box, Large Transformer/Filter
15	108-1728	Cable Assembly, Transformer Box Line GL230, 330, 430, 230 and 330 CE Export and 430 CE Export Filter Pump
16	106-8168	Cable Assembly, Transformer Box Line GL230 CE Export
17	106-8170	Cable Assembly, Transformer Box Filter Pump GL230, 330, 230 and 330 CE Export
18	108-0994	Cable Assembly, Transformer Box #1 GL230,330, 230 and 330 CE Export
19	108-0995	Cable Assembly, Transformer Box #2 GL230, 330, 230 and 330 CE Export
20	108-0996	Cable Assembly, Transformer Box #3 GL330 and 330 CE Export
21	108-1778	Harness Assembly, Vat # 4
22	108-1777	Harness Assembly, Vat # 3
23	108-1789	Harness Assembly, 4 Batt Cordset
24	823-7638	Box, Transformer/Filter GL30 4-Battery
*	WIR 0798	Wire Assembly, GL230/330 Transformer/Filter Box (used in Items A, B, C and D)
*	WIR 0957	Wire Assembly, GL230/430 (used in Items A, B, C and D)
*	WIR 0958	Wire Assembly, GL 430 (used in Item E)
*	108-3433	Harness, Bulk Oil Jumper
*	108-3432	Harness, T-Box Gas OCF

\* Not illustrated

√ Recommended parts.

## 2.6 Wiring

### 2.6.1 Main Wiring Harnesses

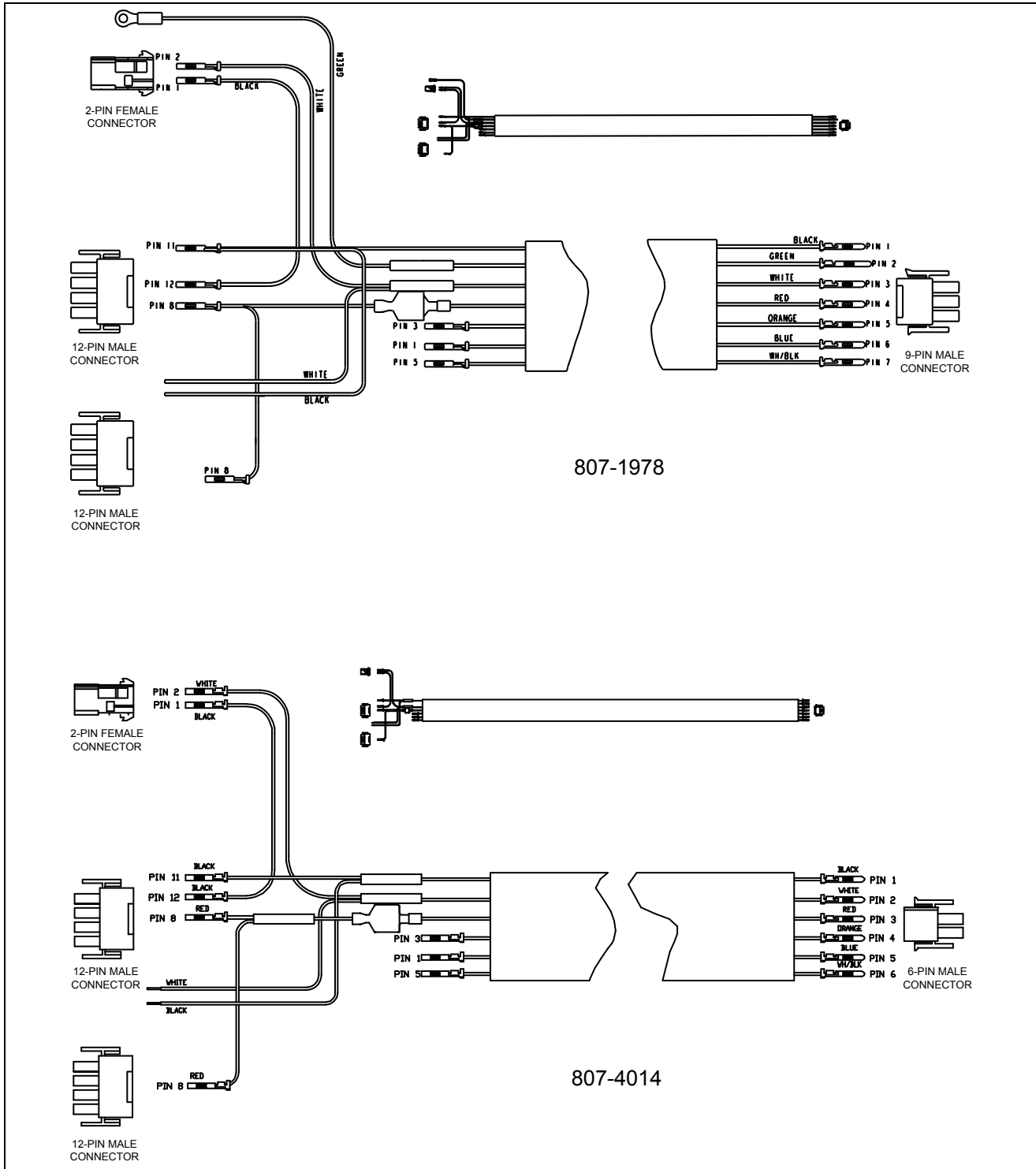

ITEM	PART #	COMPONENT
	807-1978	Main Wiring Harness 250/450
	807-4014	Main Wiring Harness 350

**2.6.2 3000 and ATO Wiring Harnesses** (Refer to wiring diagram on page 1-50.)

ITEM	PART #	COMPONENT
*	807-4546	Controller Communication (used from controller to controller)
*	807-4646	Controller Communication (used from right controller to ATO box)
*	807-4655	Harness RTD Medium (used from ATO RTD to ATO Board)
*	826-2569	FV/DV ATO/RTD Probe Kit
*	807-4553	ATO Power (used from transformer to ATO board #1)
*	807-5163	ATO Power ATO Secondary Box (used from transformer to ATO board #2)
*	807-4719	ATO Pump and JIB (used from ATO Board to Top-off Pump and JIB Reset Switch)
*	807-5161	Harness, ATO Solenoid, Pump Relay Primary (used from ATO Board to Top-off Pump Relay, Solenoids, and JIB Reset Switch)
*	807-5162	Harness, Secondary ATO Solenoid, Pump Relay (used in second ATO box on 4 battery fryers from ATO Board to Top-off Pump Relay and Solenoids)
*	807-4573	Controller Locator Wire (used from controller to interface board) See wiring diagram 805-1855 on page 1-51 for locator pin positions.
*	807-4552	Communications Terminator (used on controller pin J6 and ATO board pin J10 to terminate network)
	807-4657	Jumper (used on 4 and 5 battery ATO board plug J5 pin 7 and 8)
*	106-9544	Long Top-off Power (used between ATO box #1 and #2)
√ *	807-4660PK	SMT Pin Service Repair Kit
√ *	230-2345	SMT Pin Extractor

\* Not illustrated.

√ Recommended parts.

See page 1-30 and 1-39 for Pin Positions.



## 2.7 Frypots and Associated Components

### 2.7.1 Full-Vat Frypot Components

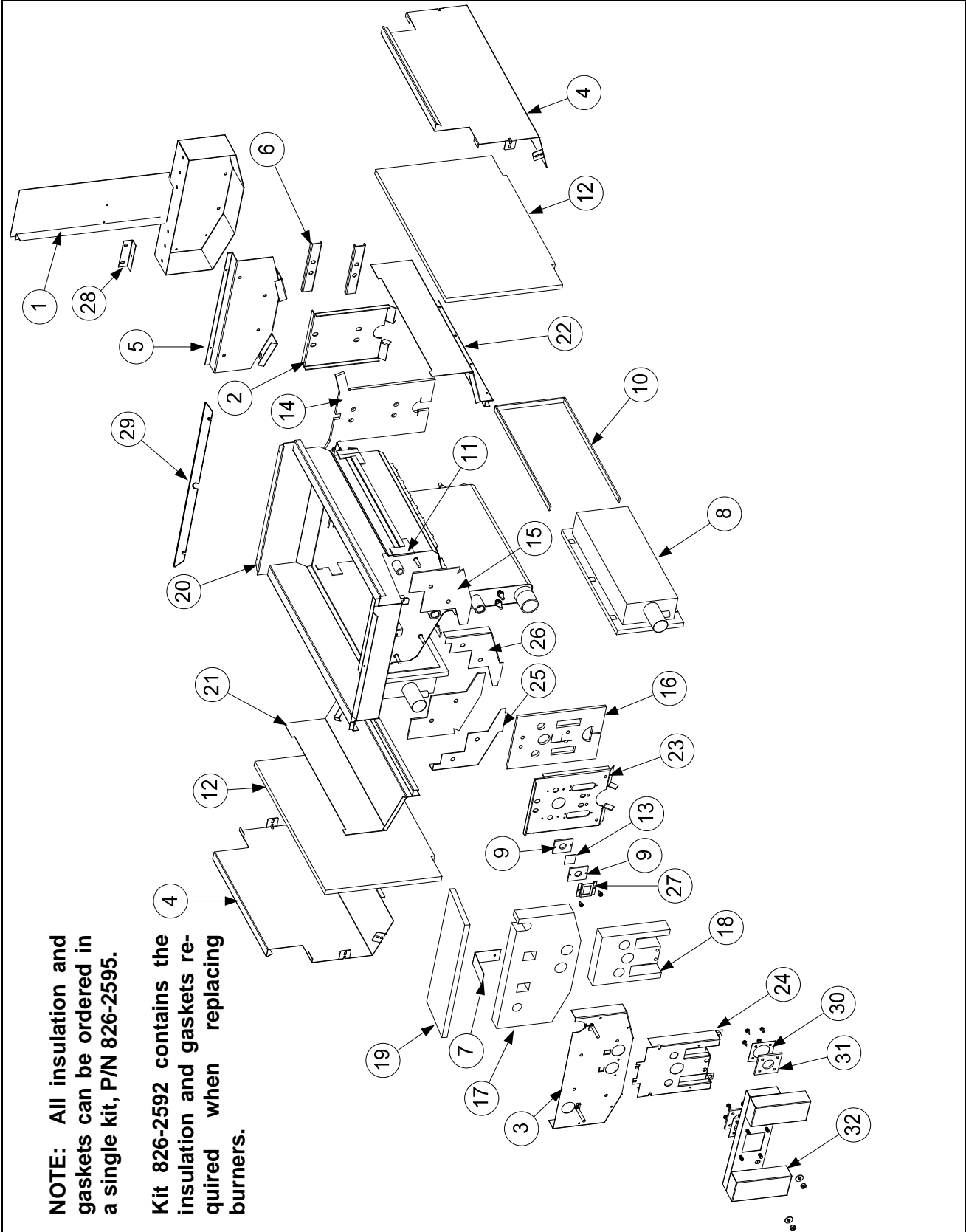

**NOTE:** All insulation and gaskets can be ordered in a single kit, P/N 826-2595.

Kit 826-2592 contains the insulation and gaskets required when replacing burners.

## 2.7.1 Full-Vat Frypot Components cont.

ITEM	PART #	COMPONENT
	108-2222SP	Frypot Assy Full-Vat OCF with filter (NAT)
	108-2224	Frypot Assy Full-Vat OCF with filter (PRO)
	108-2849	Frypot Assy Full-Vat OCF non-filter (NAT)
	108-2848	Frypot Assy Full-Vat OCF non-filter (PRO)
	826-2595	Insulation Kit, Complete Full-Vat
	826-2592	Insulation Kit, Burner Full-Vat
1	108-2897	Flue Assembly, Full-Vat
2	220-6470	Back, Lower Full-Vat Combustion Chamber
3	220-6529	Retainer, Full-Vat Upper Insulation
4	220-7831	Retainer, Outer Frypot
5	230-6960	Plate, FV Collector Mounting
6	220-2851	Brace, FV Rear Insulation
7	220-2920	Brace, Foam Deck Insulation
√ 8	810-3435	Burner, Universal Replacement
9	812-0356	Insulation, Burner Sight Glass
10	816-0900	Insulation, Burner
11	812-0706	Insulation, Upper Burner Rail
12	812-1029	Insulation, Combustion Chamber Side
13	814-0048SP	Glass, Burner Sight
14	816-0837	Insulation, FV Rear Lower
15	816-0731	Insulation, FV LH/RH Front Seal
16	816-0732	Insulation, FV Lower Inner Front
17	816-0733	Insulation, FV Front Upper
18	816-0978	Insulation, FV Outer Front
19	816-0746	Insulation, Foam Deck
20	823-7824	Frypot, FV OCF with filter <i>prior to 07/2014</i>
	823-8975	Frypot, FV OCF with filter <i>after 06/2014</i>
	823-8022	Frypot, FV OCF without filter <i>prior to 07/2014</i>
	823-8976	Frypot, FV OCF without filter <i>after 06/2014</i>
21	823-7454	Retainer, FV LH Upper Burner
22	823-7455	Retainer, FV RH Upper Burner
23	823-7279	Retainer, FV Front Insulation
24	823-7415	Retainer, FV Outer Front
25	824-2164	Front Upper Seal Weldment, FV LH
26	824-2165	Front Upper Seal Weldment, FV RH
27	900-1031	Retainer, Burner Sight Glass
28	930-0818	Bracket, Flue to Pot
29	900-4253	Strip, Fluecap Retainer
30	900-1049	Retainer, Plenum Gasket
31	816-0057	Gasket, Plenum
32	823-8574	Plenum, Full-Vat ( <i>use 823-8590 for CE and export Non-CE units</i> )
*	816-0059	Gasket, Ignitor

\* Not illustrated.

√ Recommended parts.

## 2.7.2 Dual-Vat Frypot Components

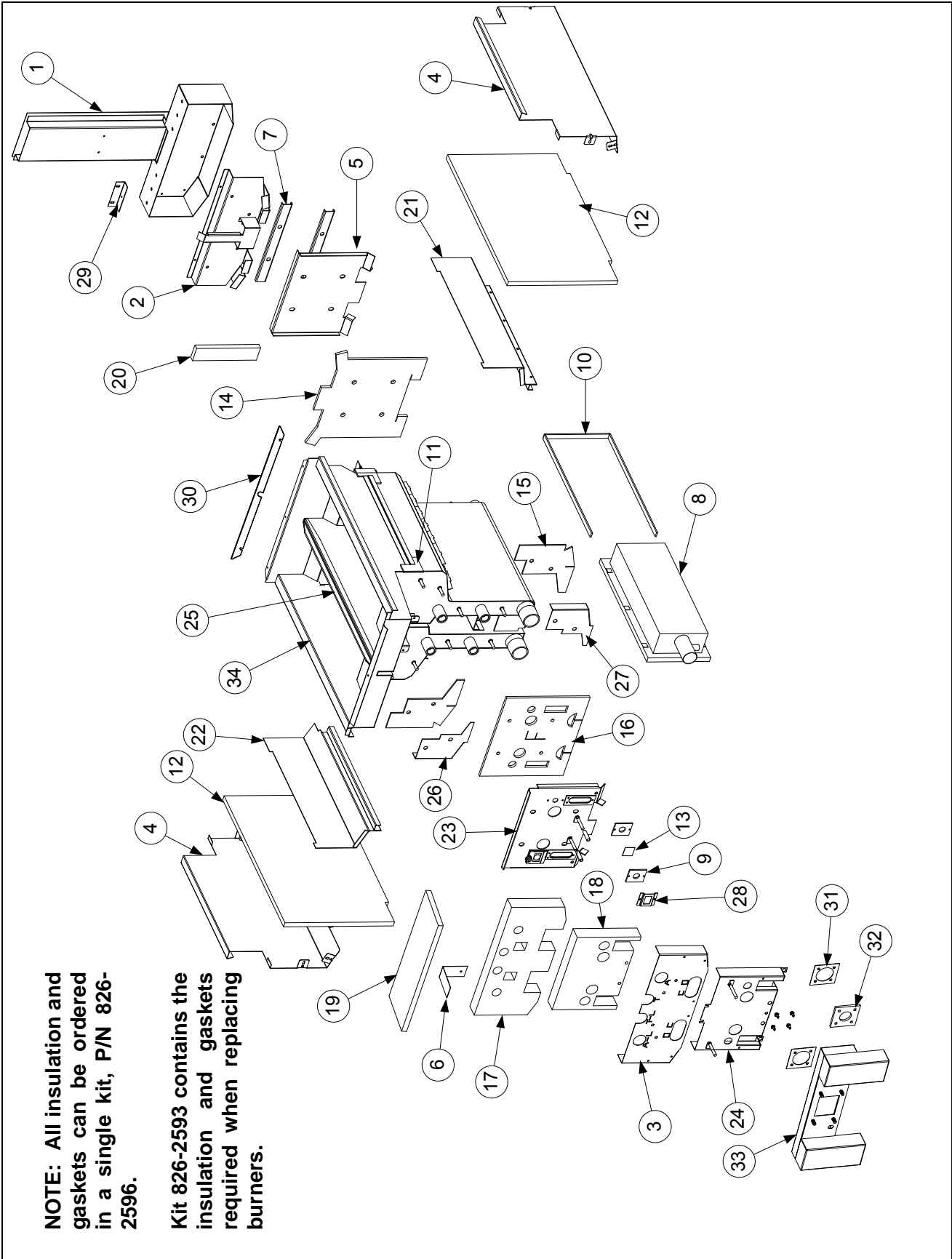

## 2.7.2 Dual-Vat Frypot Components cont.

ITEM	PART #	COMPONENT
	108-2223SP	Frypot Assy Dual-Vat OCF with filter (NAT)
	108-2225	Frypot Assy Dual-Vat OCF with filter (PRO)
	108-2845	Frypot Assy Dual-Vat OCF non-filter (NAT)
	108-2844	Frypot Assy Dual-Vat OCF non-filter (PRO)
*	826-2596	Insulation Kit, Complete Dual-Vat
*	826-2593	Insulation Kit, Burner Dual-Vat
1	108-2898	Flue Assembly, Dual-Vat
2	106-7960	Plate Assembly, Dual-Vat Collector
3	220-6530	Retainer, Dual-Vat Upper Insulation
4	220-7916	Retainer, Dual-Vat Outer Frypot
5	220-6180	Back, Dual-Vat Lower Combustion Chamber
6	220-2920	Brace, Foam Deck Insulation
7	220-2972	Brace, Dual-Vat Rear Insulation
√ 8	810-3435	Burner, Universal Replacement
9	812-0356	Insulation, Burner Sight Glass
10	816-0900	Insulation, Burner
11	812-0706	Insulation, Upper Burner Rail
12	812-1029	Insulation, Combustion Chamber Side
13	814-0048SP	Glass, Burner Sight
14	816-0838	Insulation, Dual-Vat Rear Lower
15	816-0741	Insulation, Dual-Vat LH/RH Front Seal
16	816-0742	Insulation, Dual-Vat Lower Inner Front
17	816-0743	Insulation, Dual-Vat Front Upper
18	816-0979	Insulation, Dual-Vat Outer Front
19	816-0746	Insulation, Foam Deck
20	812-0688	Insulation, Flue Collection
21	823-7457	Retainer, Dual-Vat RH Upper Burner
22	823-7456	Retainer, Dual-Vat LH Upper Burner
23	823-7416	Retainer, Dual-Vat Front Insulation
24	823-7417	Retainer, Dual-Vat Outer Front
25	824-1796	Riser W/A Dual-Vat Pot
26	824-2166	Dual-Vat LH Upper W/A Seal
27	824-2167	Dual-Vat RH Upper W/A Seal
28	900-1031	Retainer, Burner Sight Glass
29	930-0818	Bracket, Flue to Pot
30	900-4253	Strip, Fluecap Retainer
31	900-1049	Retainer, Plenum Gasket
32	816-0057	Gasket, Plenum
*	816-0059	Gasket, Ignitor
33	823-8573	Plenum, Dual-Vat ( <i>use 823-8589 for CE and export Non-CE units</i> )
34	823-7862	Frypot, Dual-Vat OCF with filter <i>prior to 07/2014</i>
	823-8973	Frypot, Dual-Vat OCF with filter <i>after 06/2014</i>
	823-8020	Frypot, Dual-Vat OCF without filter <i>prior to 07/2014</i>
	823-8974	Frypot, Dual-Vat OCF without filter <i>after 06/2014</i>

\* Not illustrated.

√ Recommended parts.

### 2.7.3 Frypot Probes and Thermostats

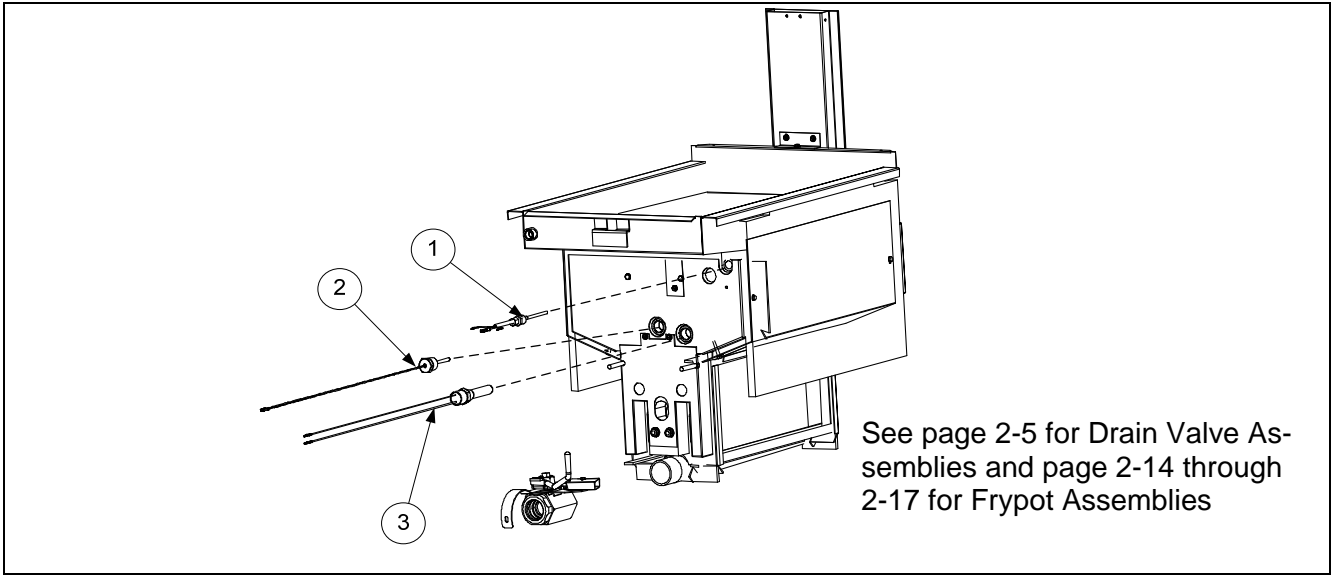

ITEM	PART #	COMPONENT
1	826-2706	Probe, RTD ATO Kit
2	826-2900	Probe, Temperature Cooking
3	826-1177	Thermostat, High-Limit 425°F/218°C

\* Not illustrated.

## 2.8 Gas Valves, Supply and Combustion System Components

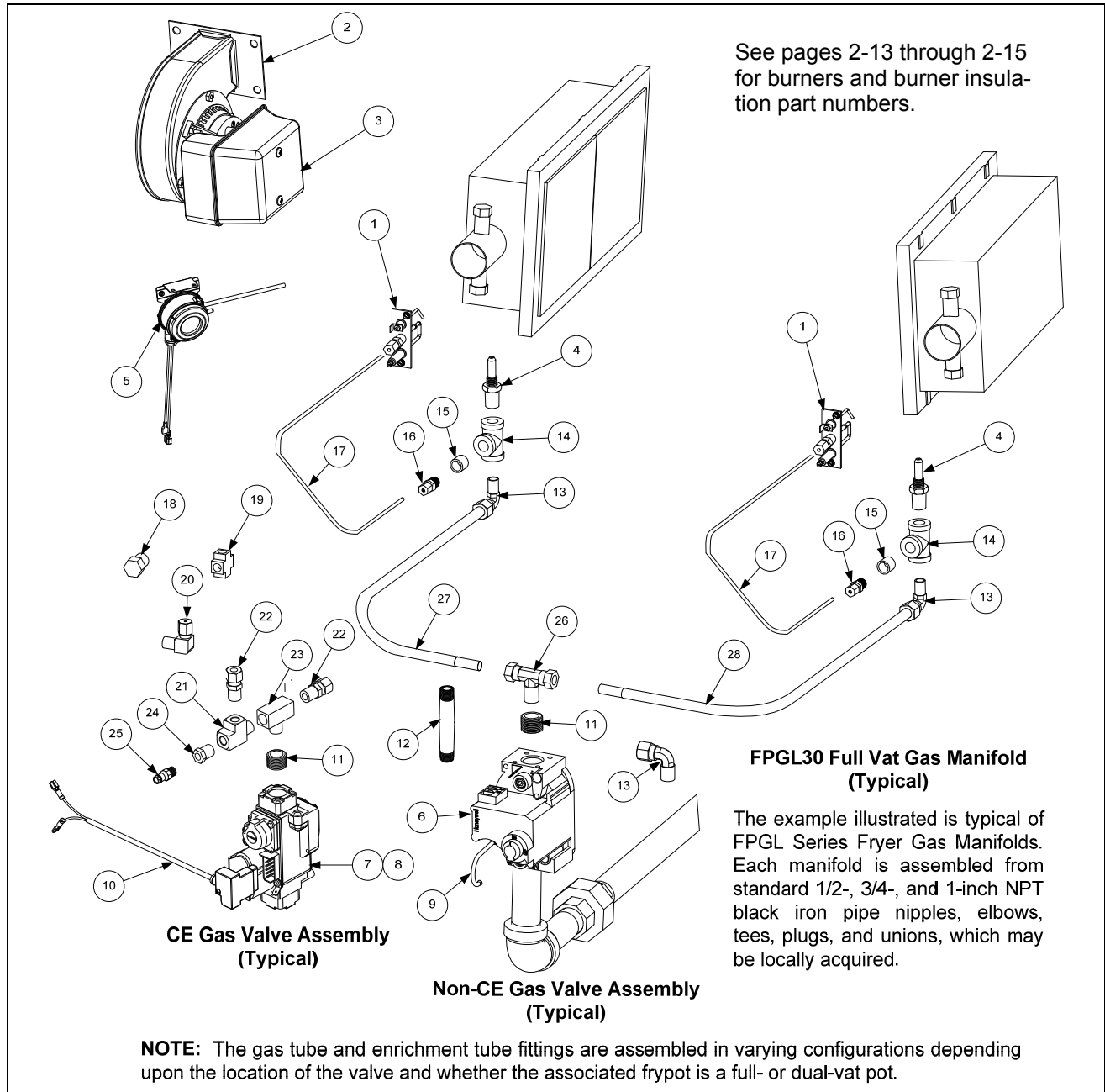

ITEM	PART #	COMPONENT
√ 1		Ignitor
	826-3053	Natural Gas (G20, G25)
	826-2994	Propane (G30, G31)
√ 2		Blower Assembly, Combustion Air (includes harness and Item 3)
	106-2997SP	115V 50/60 Hz (Right)
	108-3307	220V 60 Hz (Right)
	106-2998SP	208-240V 50/60 Hz (Right) Non-CE International
	106-3001SP	230V 50/60 Hz CE (Right) CE (Wide Body)
3	816-0554	Cover, Blower Motor (component of all blowers listed above)
*	806-8806SP	Harness Assembly, Blower Motor (component of all blowers listed above)

## 2.8 Gas Valves, Supply and Combustion System Components cont.

ITEM	PART #	COMPONENT
4		Orifice, Burner
**	810-3977	1.88mm 75% Butane/25% Butane (Standard Elevation)
**	810-3865	1.95mm Propane/Butane (G30, G31) Australia Only
**	810-3860	2.05 mm Propane/Butane (G30, G31) (0-4999 Ft, 0-1524 M)
**	810-3863	2.10 mm Propane/Butane (G30, G31) (5000-6999 Ft, 1525-2133 M)
**	810-3867	2.84mm Natural Gas (G20, G25) Australia Only DV
**	810-3866	2.92mm Natural Gas (G20, G25) Australia Only FV
**	810-3864	3.18 mm Natural Gas (G20, G25) (0-4999 Ft, 0-1524 M) CE
**	810-3861	3.26 mm Natural Gas (G20, G25) (0-4999 Ft, 0-1524 M)
**	810-3862	3.40 mm Natural Gas (G20, G25) (5000-6999 Ft, 1525-2133 M)
√ 5	108-1455	Switch, Air Pressure Assembly (807-2141 switch alone)
√ 6		Valve, Non-CE Gas
	826-1122	Natural Gas (G20, G25)
	826-1120	Kit Natural Gas w/ flexlines and hardware
	826-1123	Propane Gas (G30, G31)
	826-1121	Kit, Propane Gas w/ flexlines and hardware
√ 7	810-1715	Valve, CE Gas (G20, G25, G30, G31)
8	810-1041	Accessory Kit (contains parts to adapt Item 7 to specific fryer configuration)
9	810-0691	Tube, 1/8-inch Vent
10	806-9678SP	Plug Assy, CE Gas Valve
11	813-0304	Bushing, 1/2-inch NPT to 1/4-inch NPT Flush Reducing
12	813-0700	Nipple, 1/4-inch NPT x 3-inch
13	813-0302	Elbow, 1/4-inch Male NPT to 3/8-inch Tube 90° (used on DV valve)
14	813-0449	Tee, 1/4 -inch NPT Brass
15	810-3147	Bushing, 3/4-inch OD x 1/2 -inch ID NPT Flush
16	813-0340	Adapter, 1/8-inch NPT to 1/8-inch Tube
17	810-3807	Tube, 1/8-inch OD X 6.5-inch Enrichment
18	813-0154	Plug, 1/8-inch NPT Hex Head Pipe
19	813-0378	Fitting, 1/8-inch NPT Cross
20	813-0354	Elbow, 1/8-inch NPT X 1/8-inch Tube Compression
21	810-1026	Tee, 1/4-inch Male NPT to Female NPT Street
22	810-1025	Connector, 1/4-inch Male NPT to 3/8-inch Tube
23	813-0495	Tee, 1/4-inch Male NPT to Female NPT
24	810-1006	Bushing, 1/4-inch NPT to 1/8-inch NPT Reducing
25	810-1176	Tap, 1/8-inch NPT Pressure
26	813-0301	Tee, 1/4-inch Male NPT to 3/8-inch Tube
27	810-1353	Gas Line, 3/8-inch OD X 9-inch SS Flexible (Used on some split pots)
28	810-1355	Gas Line, 3/8-inch OD X 15-inch SS Flexible
*	826-3278	Conversion Kit, Natural Gas FV (G20, G25) to Propane/Butane(G30,G31) Non-CE
*	826-3279	Conversion Kit, Natural Gas DV (G20, G25) to Propane/Butane(G30,G31) Non-CE
*	826-2967	Conversion Kit, Propane/Butane FV(G30, G31) to Natural Gas (G20,G25) Non-CE
*	826-2968	Conversion Kit, Propane/Butane DV(G30, G31) to Natural Gas (G20,G25) Non-CE
*	826-2969	Conversion Kit, Nat Gas FV (G20, G25) to Prop/Butane(G30,G31) Aust Non-CE
*	826-2970	Conversion Kit, Nat Gas DV (G20, G25) to Prop/Butane(G30,G31) Aust Non-CE
*	826-2971	Conversion Kit, Prop/But FV(G30, G31) to Natural Gas (G20,G25) Aust Non-CE
*	826-2972	Conversion Kit, Prop/But DV(G30, G31) to Natural Gas (G20,G25) Aust Non-CE
*	826-3278	Conversion Kit, Nat Gas (G20, G25) to Prop/Butane(G30,G31) CE
*	826-2976	Conversion Kit, Prop/But (G30, G31) to Natural Gas (G20,G25) CE

\* Not illustrated.

√ Recommended parts.

## 2.9 Filtration System Components

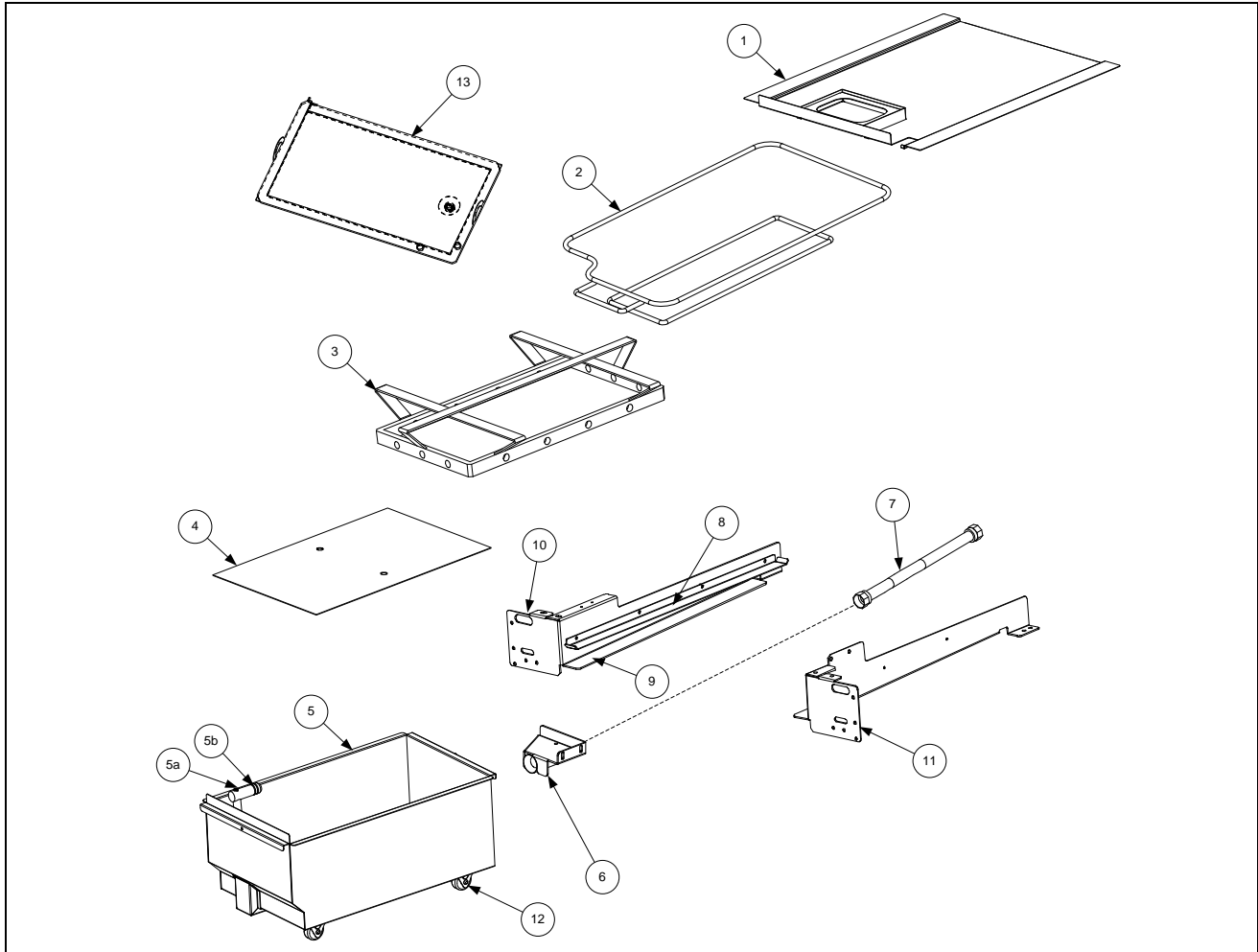

ITEM	PART #	COMPONENT
1	823-8028	Lid, Filter Pan ( <i>use 823-7976 for Single Fryer Lid</i> )
2	810-3288	Crumb Tray
3	810-3289	Hold-Down Ring 11.20 x 19.10,
4	812-2025	SanaGrid Filter Screen
5	108-2880SP	Pan, Filter with casters
	108-6976SP	Pan, Filter with casters ( <b>Only for use with Filter Leaf 810-4492</b> )
	106-8211SP	Pan, Filter without casters prior to May 2012
	806-9255	Pan, Filter Single Fryer
	813-0568	Plug, 1/8-inch Socket Head Pipe (used with Item 5; two required)
√ *	826-1392	O-Ring (Pkg. of 5; used with Item 5)
6	823-6458	Suction Tube Assembly
	823-5591	Suction Tube Assembly ( <i>Single Fryer Only</i> )
7	810-1067	Flexline, 8.50-inch Oil Return
8	230-8373	Rail, Upper Filter Pan Left/Right
9	230-8372	Rail, Lower Filter Pan Left/Right
10	823-8030	Support, Left Filter Pan
11	220-8368	Support, Right Filter Pan 3,4 and 5 battery ( <i>use 108-2872 for 2 battery</i> )
12	810-4137	Caster, 2"
13	810-4492	Leaf Assy, Filter ( <b>Only for use with Filter Pan 108-6976SP</b> )

\* Not illustrated.

√ Recommended parts.



## 2.10 Filter Pump, Motor and Associated Components

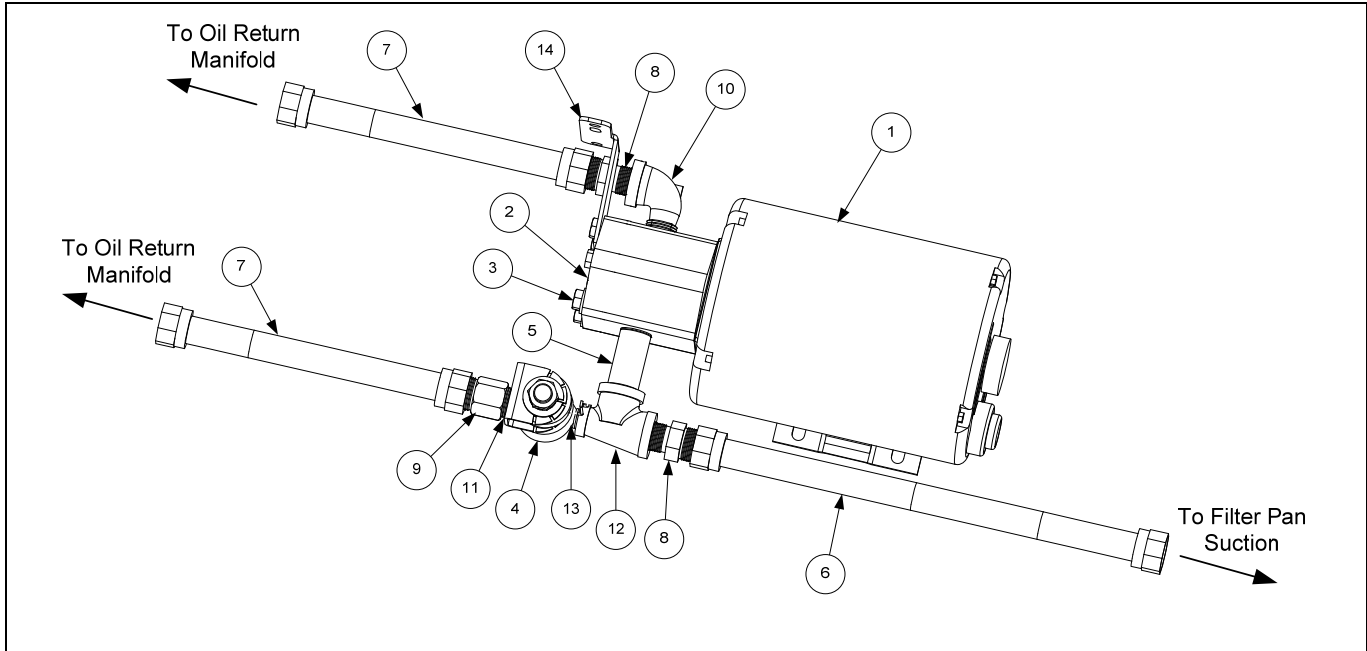

ITEM	PART #	COMPONENT
1		Motor and Gasket Kit
	826-1785	100V 50/60 Hz
√	826-1712	115V 50/60 Hz
√	826-1756	208V 50/60 Hz
	826-1270	220-240V 50/60 Hz
	826-1755	250V 50/60 Hz
2	826-3191	Pump and Gasket Kit, Viking 4 GPM (includes gasket and cap screws below)
	816-0093	Gasket, Pump/Motor
3	809-1062	Cap Screw, 5/16-inch-18 4.00" NC Hex (Connects pump to motor.)(use 8090194 washers)
*	108-0649	Heater Strip Assembly, 100-120V 25W 18"
*	106-5912	Heater Strip Assembly, 208-250V 25W 18"
4	106-7598SP	Valve, Solenoid 1/4-inch" NPT
5	813-0265	Nipple, 1/2-inch x 2.50-inch NPT BM
6	810-1057	Flexline, 13-inch Oil Return
7	810-1067	Flexline, 8.5-inch Oil Return
8	810-1668	Adapter, 5/8-inch to 1/2-inch NPT Male
9	810-1669	Adaptor, Female 7/8-inch OD x 1/2-inch
10	813-0165	Elbow, ST 1/2-inch x 1/2-inch NPT 90° BM
11	813-0304	Bushing, 1/2-inch x 1/4-inch BM Flush
12	813-0530	Tee, Reducing 1/2-inch x 1/4-inch x 1/2-inch
13	813-0838	Nipple, 1/4-inch NPT BM Close
14	220-6191	Brace
*	106-1020	Wiring, Pump

\* Not illustrated.

√ Recommended parts.

## 2.11 Frypot Assemblies and Associated Parts

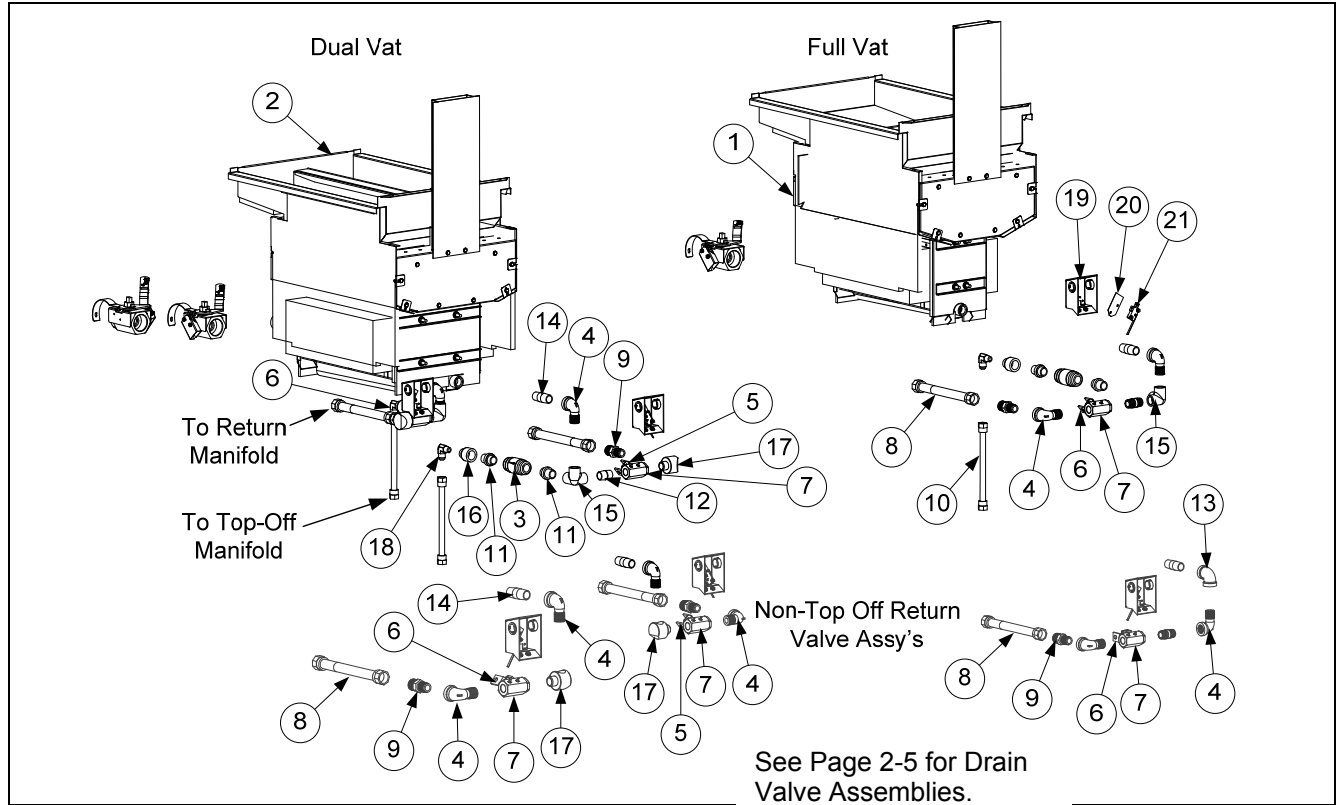

ITEM	PART #	COMPONENT
1	823-7824	Frypot, Full-Vat OCF with filter <i>(use 823-8022 for frypot with no filter) prior to 07/2014</i>
	823-8975	Frypot, Full-Vat OCF with filter <i>(use 823-8976 for frypot with no filter) after 06/2014</i>
2	823-7862	Frypot, Dual-Vat OCF with filter <i>(use 823-8020 for frypot with no filter) prior to 07/2014</i>
	823-8973	Frypot, Dual-Vat OCF with filter <i>(use 823-8974 for frypot with no filter) after 06/2014</i>
*	824-1796	Riser, DV Frypot
3	810-0667	Valve, Check ½" 1 PSI
4	813-0165	Elbow, St ½" x ½" NPT 90° BM
5	901-2772	Handle, Valve Rear Flush LT
6	902-2772	Handle, Valve Rear Flush RT
*	900-2935	Retainer, Nut Oil Return Valve
7	810-2201	Valve, Return ½" Ball LT
8	810-1067	Flexline, ⅝" OD x 8.50" Long Return Oil
9	810-1668	Adaptor, Male ⅝" OD x ½"
10	810-3591	Flexline, ½" OD x 8.00" Long Top Off
11	810-3738	Adaptor, Check Valve Close NPL
12	813-0022	Nipple, ½" Close NPT BM
13	813-0062	Elbow, ½" BM x 90°
14	813-0298	Nipple, ½" x 2.00" NPT BM Pipe
15	813-0331	Elbow, V-Side Outlet ½" NPT
16	813-0555	Reducer, Bell ½" to ¼" NPT BM
17	813-0908	Adapter, ½" NPT 90° <i>(also used in DV non-Top Off manifolds in place of item 4)</i>
18	813-0940	Elbow, ¼" NPT x ⅜" Flare
19	2208540	Cover, Oil Return Microswitch
20	816-0220	Insulation, RF Switch
21	807-4101	Switch, Micro

\* Not illustrated.

√ Recommended parts.

## 2.12 Oil Return System Components

### Typical Rear-Flush Oil Return Plumbing

Return valve assemblies are shown on preceding page.

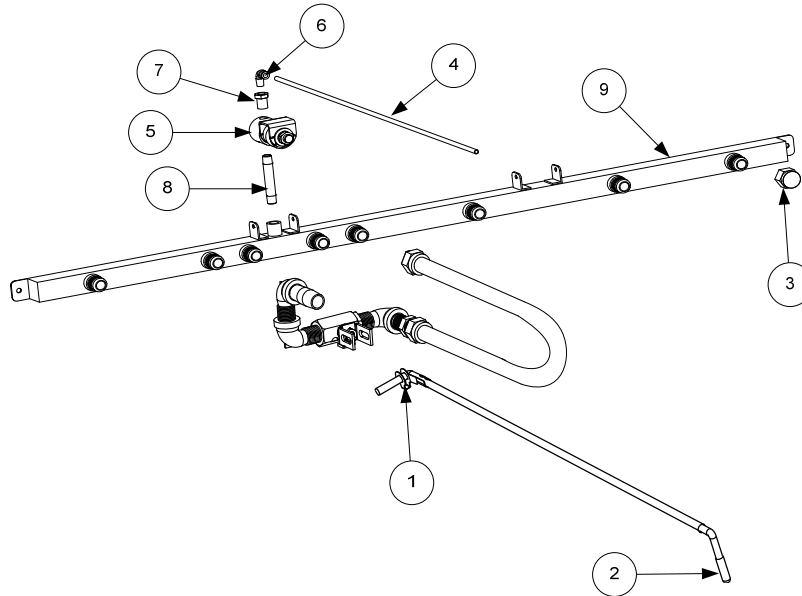

ITEM	PART #	COMPONENT
1	809-0601	Clip, Clevis
2	816-0643	Grip, Oil Return Valve Handle
3	813-0907	Cap, 15/16-inch Valve Safety
4	811-1071	Tube, 1/4-inch OD Teflon Manifold Vent
5	108-2555SP	Valve, 1/4-inch NPT Solenoid
6	810-2493	Elbow, 90° 1/8-inch NPT x 1/4-inch Quick Connect
7	813-0807	Bushing, 1/4-inch NPT x 1/8-inch
8	813-0700	Nipple, 1/4-inch NPT x 3.00-inch
9		Manifolds
*	810-3958	Manifold, Two-Station Fryer ( <i>use 810-2543 for non-filter units</i> )
*	810-3959	Manifold, Three-Station Fryer ( <i>use 810-2544 for non-filter units</i> )
*	810-3960	Manifold, Four-Station Fryer ( <i>use 810-2545 for non-filter units</i> )

\* Not illustrated.

## 2.13 Auto Top-Off Components

### 2.13.1 Automatic Top-Off Box Assembly

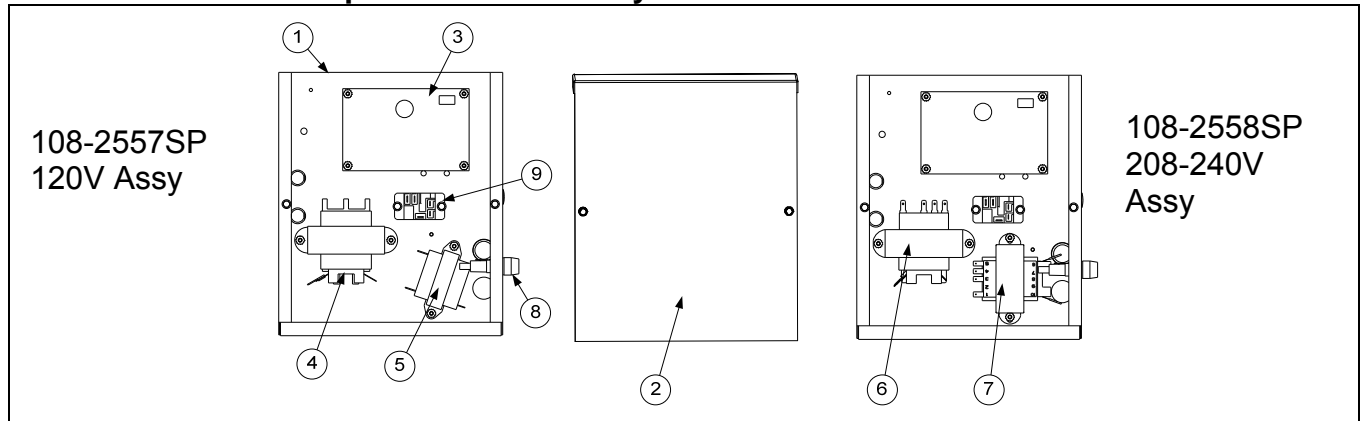

ITEM	PART #	COMPONENT
1	108-2556	Box, Assembly Auto Top Off Board
2	220-5679	Cover, Top Off Board Box
√ 3	108-2805	PCB Board, Automatic Top Off OCF
√ 4	807-2181	Transformer, 100-120V/24V 62VA
√ 5	807-0855	Transformer, 120V 50/60-12V 20VA
√ 6	807-2180	Transformer, 208-240V/24V 50VA
√ 7	807-2191	Transformer, 208/230/240 -12V 30VA
8	807-1321	Holder, Fuse AGC Panel Mount ¼"
√ *	807-1597	Fuse, 3A Slow-Blow
√ 9	807-1683	Relay, 12VDC (Top off pump)

\* Not illustrated.

√ Recommended parts.

**NOTE:** Top off boxes for vats 4 and 5 have either item 4 or item 6, both have item 3.

### 2.13.2 JIB (Jug In Box) Cradle, JIB Cap and Pick Up Assembly

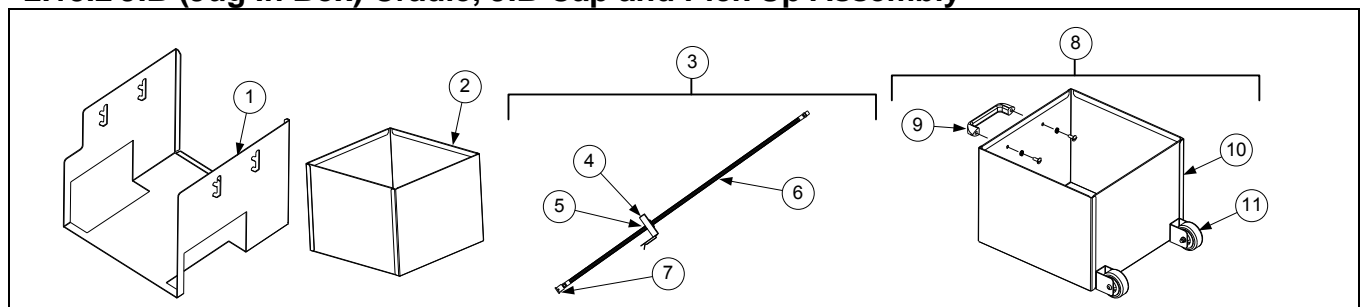

ITEM	PART #	COMPONENT
1	260-0197	Cradle, JIB, Stainless Steel (Uses 809-0402 Thumb Screw ¼-20 x ½" )
2	824-2298	Box, JIB
3	108-1049SP	Cap, JIB Assembly (use 106-9495SP for Intl. BIB)
4	823-7575	Cap, JIB (use 823-6812 for Intl. BIB)
5	810-3664	Bushing, Heyco
6	810-3663	Hose, JIB
7	810-3300	Inlet, Oil Reservoir Tube
8	108-6895	Box Assembly, JIB w/ Handle
9	810-0180	Handle
10	823-9145	Box, W/A JIB w/ handle
11	812-2337	Caster, 2"

### 2.13.3 ATO Pump Assembly

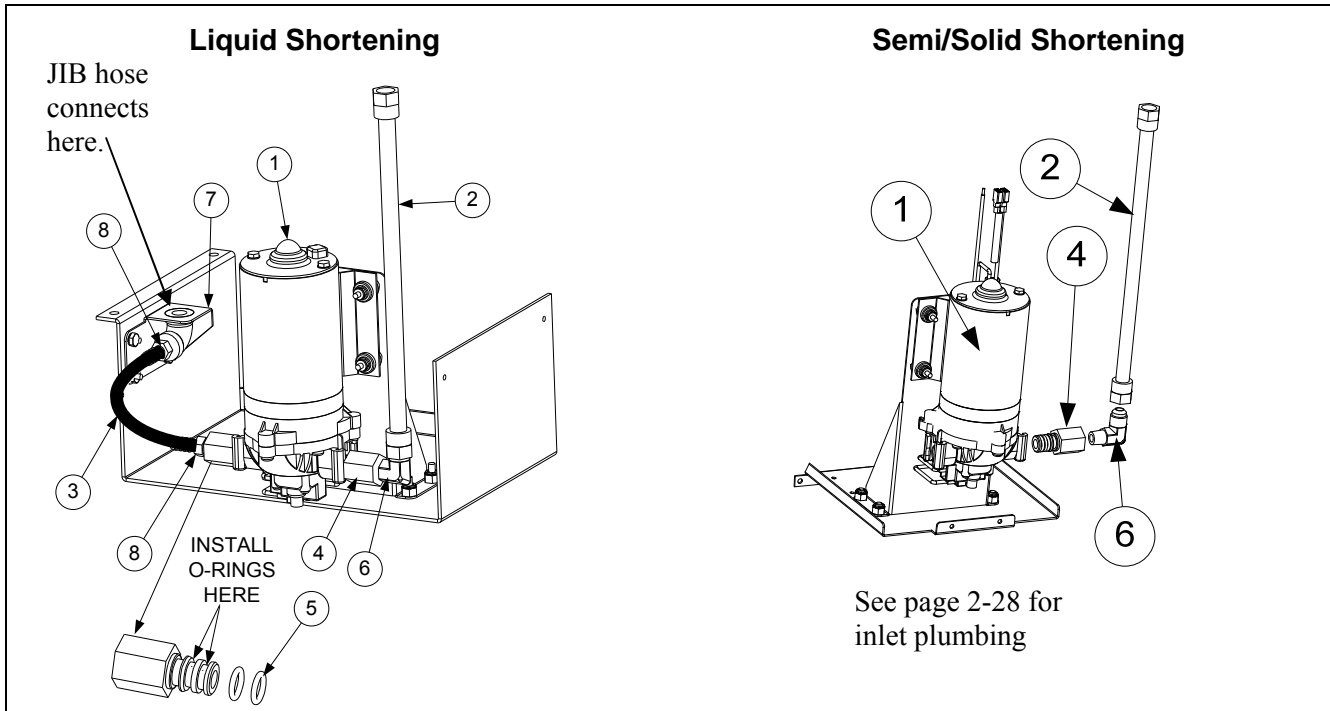

ITEM	PART #	COMPONENT
√ 1	108-0639	Pump, Shurflo 24VAC
2	810-3265	Flexline, 1/2" OD x 24-inch (Out to top off manifold)
3	811-1139	Hose, Silicone Braided (sold by the foot)
4	810-3578	Fitting, Shurflow Pump OCF
5	816-0782	O-Ring, Viton #111
6	813-0940	Elbow, 1/4" NPT x 3/8 Flare
7	823-7167	Bracket, JIB Elbow
8	816-0708	Fitting, 1/4" NPT Male Barb

√ Recommended parts.

### 2.13.4 ATO Top-Off Manifolds and Components

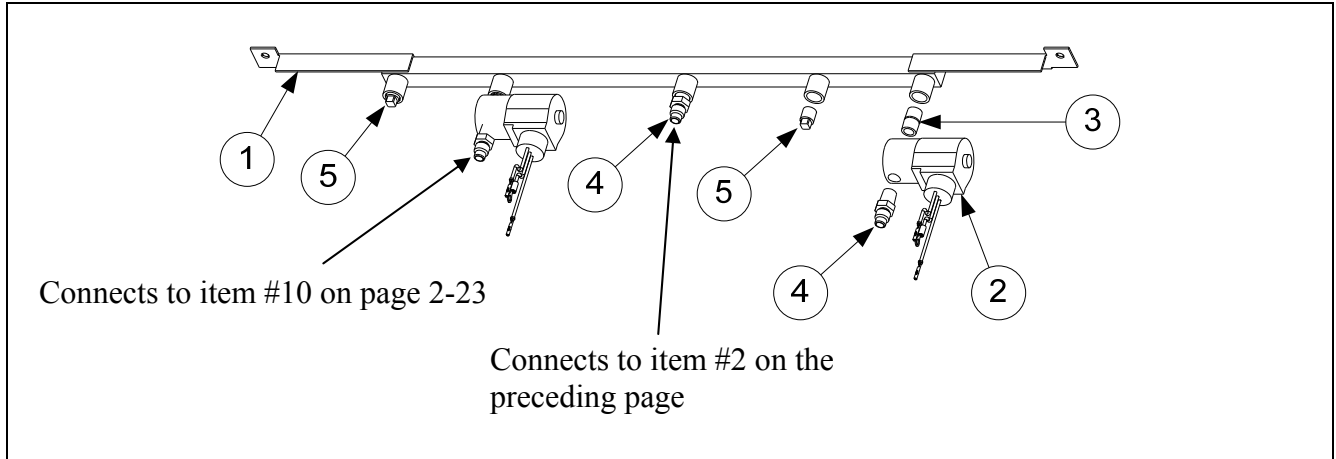

ITEM	PART #	COMPONENT
1	810-3812	Manifold, Top-Off Two Station Fryer
	810-3813	Manifold, Top-Off Three Station Fryer
	810-3814	Manifold, Top-Off Four Station Fryer
√ 2	108-2555	Solenoid Top-Off
3	813-0838	Nipple, 1/4" NPT BM Close
4	810-3270	Fitting, 3/8" Flare x 1/4" NPT
5	813-0640	Plug, 1/4" Square Head

√ Recommended parts.

### 2.13.5 Shortening Melting Unit

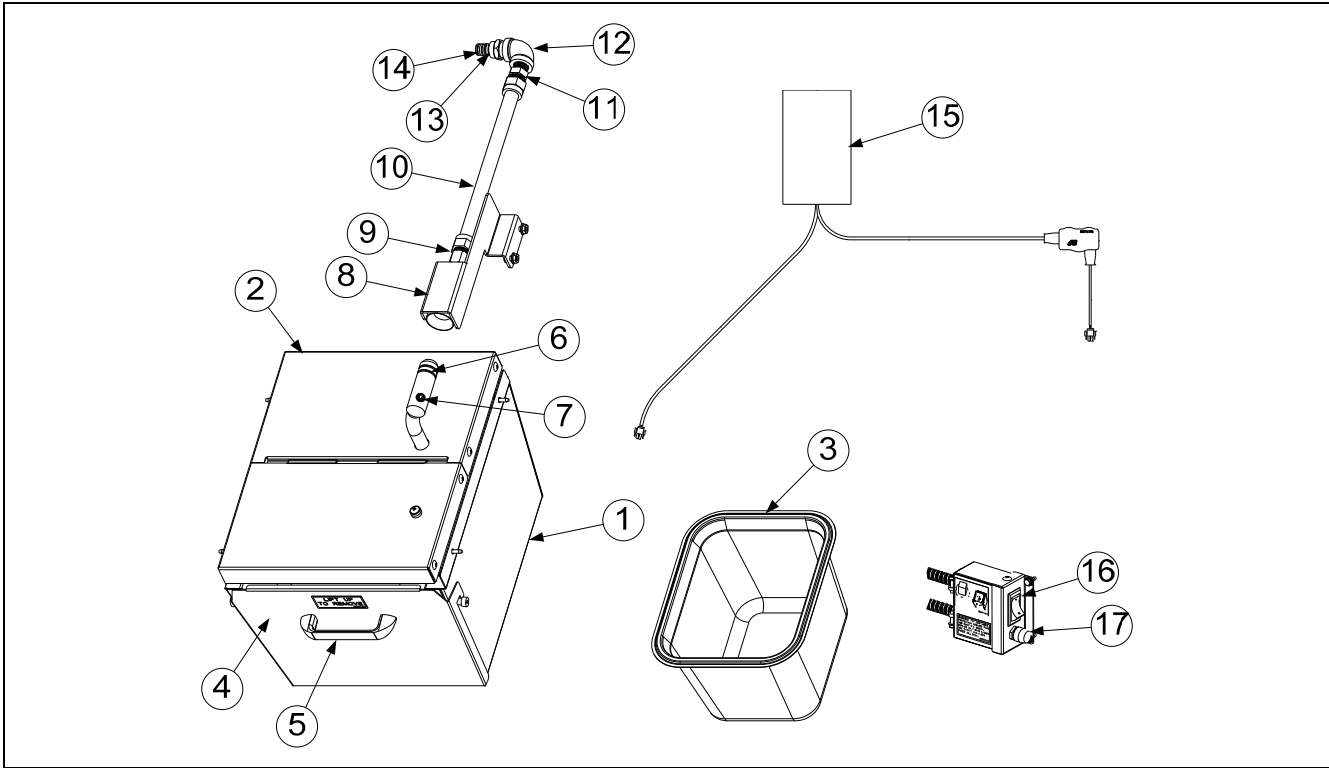

ITEM	PART #	COMPONENT
	108-3406	Assembly, Heated Shortening
1	108-2983	Box Assembly, Heated Shortening
2	108-3001	Assembly, Heated Shortening Lid
3	810-3957	Pan, Heated Shortening
4	108-3372	Cover, Shortening Box Front
5	810-0180	Handle
√ 6	826-1392	O-Ring (Pkg. of 5)
7	813-0568	Plug, 1/8-inch Socket Head Pipe
8	823-8079	Bracket W/A, Shortening Suction 3 battery
	823-8147	Bracket W/A, Shortening Suction 4 battery
9	810-1669	Adaptor, Female 7/8" OD x 1/2"
10	810-1055	Flexline, 5/8" OD x 11.5-inch
11	810-1668	Adaptor, Male 5/8" OD x 1/2"
12	813-0062	Elbow, 1/2" Blk 90° NPT BM
13	810-3820	Fitting, Quick Connect Shurflo Pump
14	816-0782	O-Ring, Viton #111
15	807-5268	Strips, Hot Box Heater with controller
16	807-4036	Switch
17	807-1321	Holder, Fuse
*	807-1555	Fuse 5 Amp
*	807-1098	Heater Strip Assembly, 240V, 25W 18"
*	807-1419	Heater Strip Assembly, 240V, 45W 36"
*	807-1473	Heater Strip Assembly, 240V, 70W 56"

\* Not illustrated.

√ Recommended parts.

### 2.13.6 Bulk Oil Relay Box and Switch

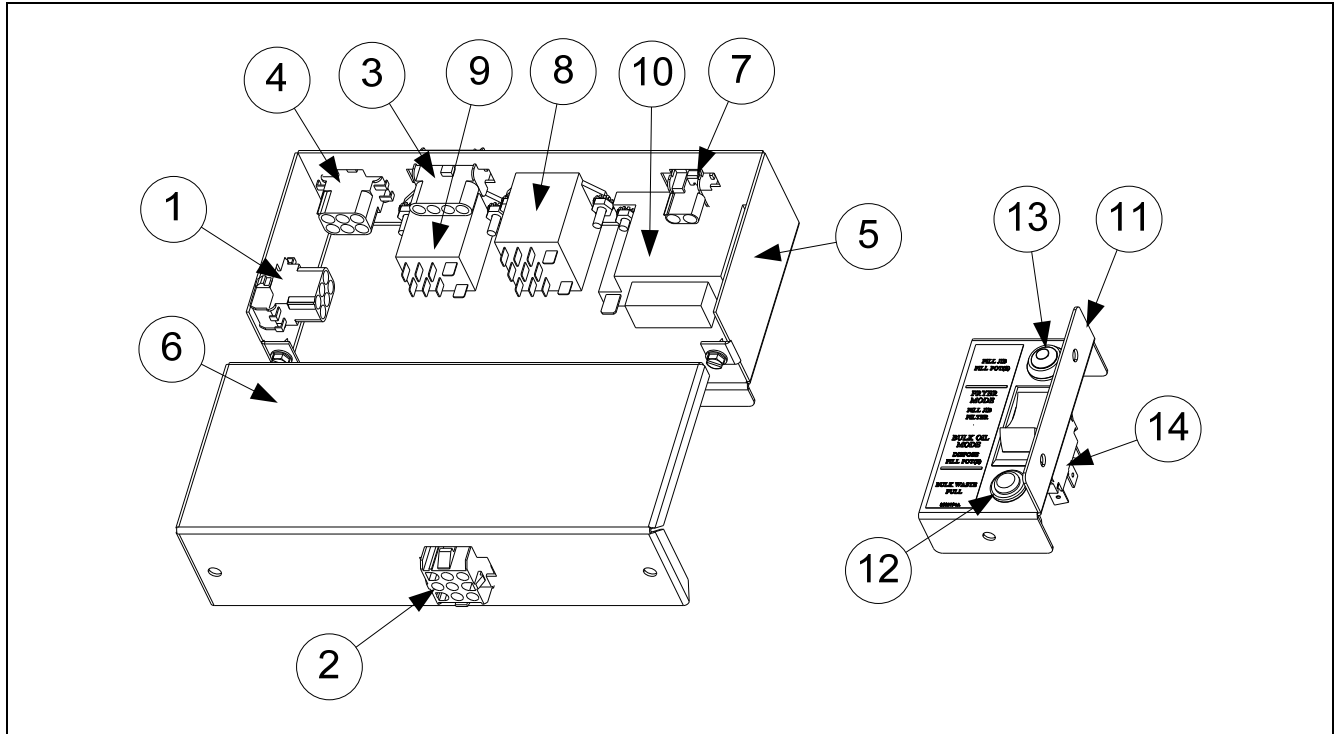

ITEM	PART #	COMPONENT
1	108-3409	Harness, Bulk Oil Power
2	108-3410	Harness, Bulk Oil Control
3	108-3412	Harness, Bulk Oil Switches
4	108-3413	Harness, Bulk Oil Communication
5	220-8665	Box, Bulk Oil Relay
6	220-8666	Cover, Bulk Oil Relay Box
7	807-1068	Connector, 2-pin
√ 8	807-5303	Relay, 24VAC 3PDT
√ 9	807-5304	Relay, 24VAC DPDT
√ 10	807-5310	Relay, 2 Second Time Delay
11	220-8706	Bracket, OCF Bulk Oil Control
12	807-5309	Light, Amber, 24VAC
√ 13	807-4678	Switch, Momentary
√ 14	807-5308	Switch, 3 Position

\* Not illustrated.

√ Recommended parts.



## 2.13.7 Bulk Oil Plumbing

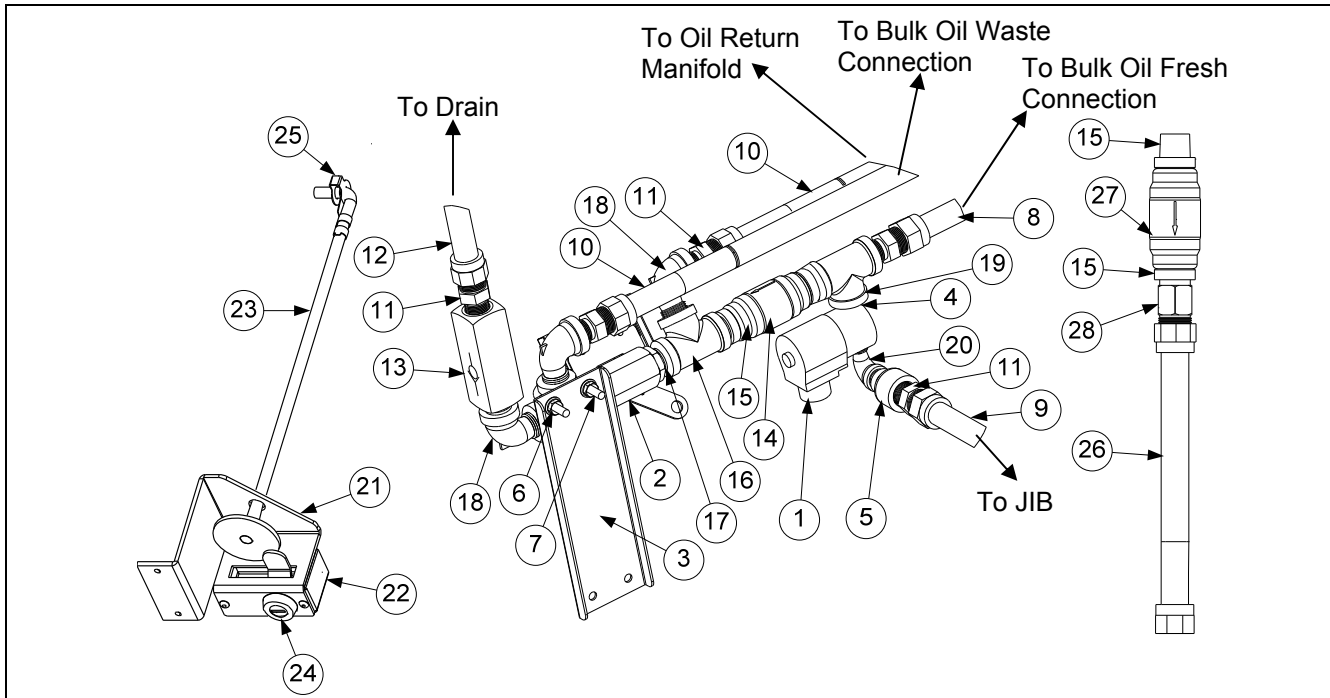

ITEM	PART #	COMPONENT
√ 1	106-6830	Solenoid Assy
2	108-3368	Valve, Assy Waste Dispose (see next page for valve assembly)
3	220-8661	Brace, Front Bulk Plumbing
4	813-0838	Nipple, 1/4" NPT
5	810-0555	Reduce, Bell 1/2" to 1/4" NPT
6	809-0417	Nut, Flange 1/4" - 20
7	809-0949	U- Bolt 1/4" - 20 x 1 1/4
8	810-1055	Flexline, 5/8" OD x 11.50"
9	810-1069	Flexline, 5/8" OD x 29.50" 3, 4 and 5 battery (use 810-1055 for two battery)
10	810-1400	Flexline, 5/8" OD x 21.00"
11	810-1668	Adaptor, Male 5/8" OD x 1/2"
12	810-1680	Flexline, 5/8" OD x 6.50"
√ 13	810-3531	Valve, Check 20 PSI (Bypass)
14	810-3583	Valve, Check 4 PSI (Manifold)
15	800-3738	Adapter, Check Valve
16	813-0003	Tee, 1/2" x 1/2" x 1/2"
17	813-0022	Nipple, 1/2" x Close NPT
18	813-0165	Elbow, St 1/2" x 1/2" NPT 90° BM
19	813-0304	Bushing, 1/2" x 1/4" BM Flush
20	813-0543	Elbow, Street 1/4" NPT
21	220-5656	Brace, Handle (use 220-8633 for 2-battery (Assembly 108-3387))
22	220-5657	Cover, Handle (use 220-8664 for 2-battery)
23	823-8118	Handle, Waste Pull
24	810-3587	Lock and Key, Waste Handle
25	809-0657	Clip, Clevis Right Rod End
26	810-1067	Flexline, 5/8" OD x 8.50"
√ 27	810-0667	Valve, Check 1 PSI (Pump Motor)
28	810-1669	Adapter, Female 7/8" OD x 1/2"

\* Not illustrated.

√ Recommended parts.

### 2.13.8 Bulk Oil Dispose Waste Valve

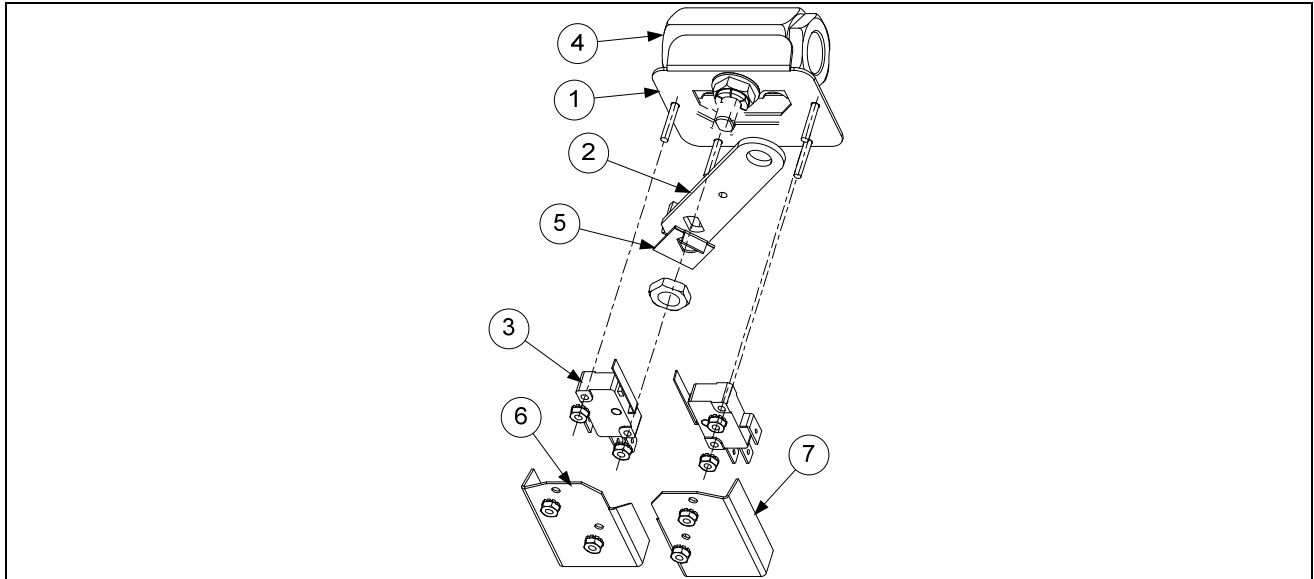

ITEM	PART #	COMPONENT
	108-3368	Valve, Dispose Waste Assembly
1	108-0445	Bracket, Waste Valve
2	220-5615	Handle, Waste Valve
√ 3	807-2103	Microswitch
4	810-0278	Valve, 1/2" Ball
5	900-2935	Retainer, Nut Return Valve
6	901-2348	Cover, DV Safety Switch
7	902-2348	Cover, DV Safety Switch

√ Recommended parts.

## 2.14 Wiring Connectors, Pin Terminals and Tools

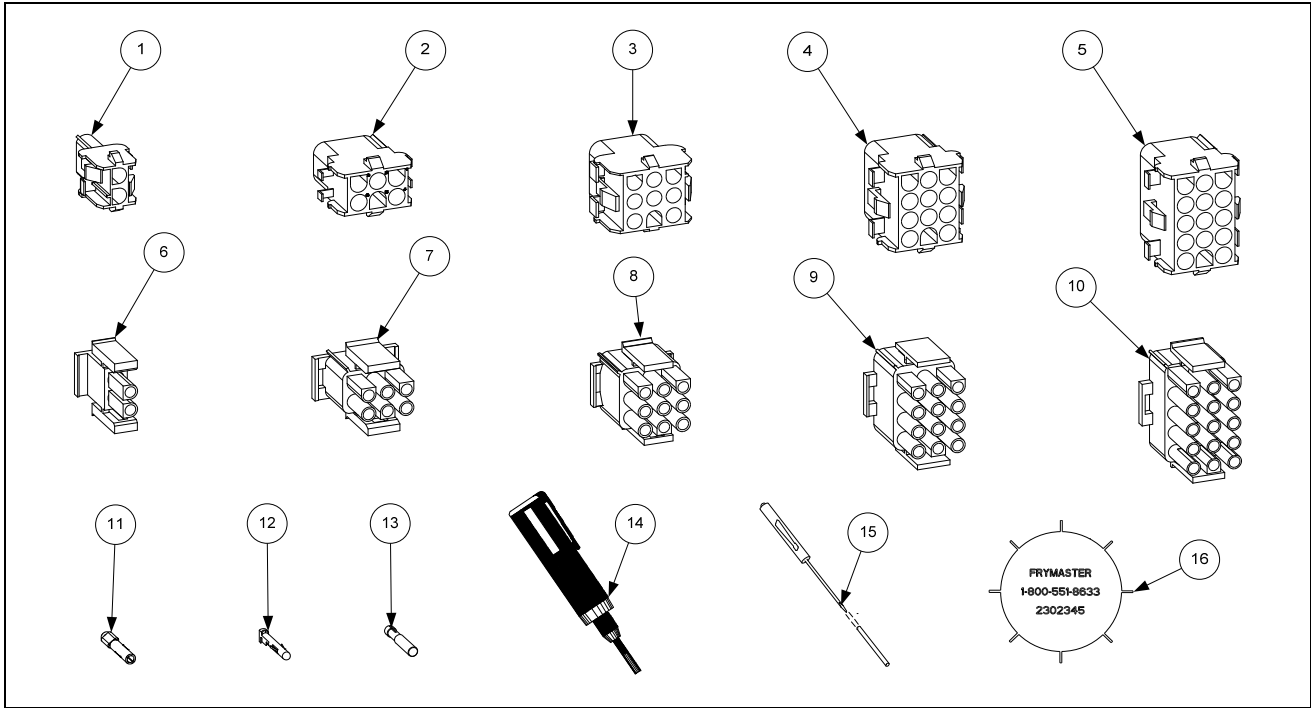

ITEM	PART #	COMPONENT
1	807-1068	2-Pin Female
2	807-0158	6-Pin Female
3	807-0156	9-Pin Female
5	807-0159	12-Pin Female
5	807-0875	15-Pin Female
6	807-1067	2-Pin Male
7	807-0157	6-Pin Male
8	807-0155	9-Pin Male
9	807-0160	12-Pin Male
10	807-0804	15-Pin Male
11	826-1341	Terminal, Female Split Pin (Pkg of 25)
12	826-1342	Terminal, Male Split Pin (Pkg of 25)
13	807-2518	Plug, Mate-N-Lock (Dummy Pin)
14	807-0928	Extract Tool Pin Pusher
15	806-4855	Pin Pusher Screwdriver Assy
16	230-2345	SMT Pin Extractor

\* Not illustrated.

## 2.15 Fasteners

ITEM	PART #	COMPONENT
*	809-0429	Bolt, ¼-inch – 20 x 2.00-inch Hex Head ZP Tap
*	809-0131	Bolt, ¼-inch -20 x ¾-inch Hex
*	809-0953	Bolt, ¼-20 x ¾-inch Hex Head
*	807-1926	Bushing, .875-inch Split
*	809-0514	Capscrew, 5/16-inch-18 NC Hex
*	809-0448	Clip, Tinnerman
*	826-1351	Nut Retainer, ¼-20 (Pkg. of 10 – for basket hanger thumbscrew) Std. Fluecap
*	809-0171	Thumbscrew, ¼-20 x 1⅜-inch (for use on Standard Fluecap)
*	826-1366	Nut, 4-40 Keps Hex (Pkg. of 25) (809-0237)
*	826-1358	Nut, 6-32 Keps Hex (Pkg. of 25) (809-0049)
*	809-0247	Nut, 8-32 Keps Hex
*	809-0052	Nut, 10-24 Hex
*	826-1376	Nut, 10-32 Keps Hex (Pkg. of 10) (809-0256)
*	809-0766	Nut, 10-32 Keps Hex SS
*	809-0581	Nut, ½ NPT Locking
*	809-0020	Nut Cap 10-24 NP
*	826-1372	Nut Grip ¼-inch ¼-20 Hex NP (Pkg. of 10) (809-0059)
*	809-0417	Nut Flange ¼-inch ¼-20 Serr
*	809-0535	Nut, "T" ¼-inch-20 x 7/16 SS
*	809-0495	Nut, ¼-inch - 20 Press
*	809-0804	Nut, ¼- inch - 20 Keps Hex
*	826-1362	Nut, ¼-20 Hex (Pkg. of 10) (809-0071)
*	809-0540	Nut, Lock ½-inch-13 Hex 2-Way ZP
*	809-0656	Screw, 4-40 X 3/8-inch Slotted Round Head
*	826-1359	Screw, 4-40 x ¾-inch Slotted Round Head (Pkg. of 25) (809-0354)
*	826-1365	Screw, 6-32 x ⅜-inch Slot Head (Pkg. of 25) (809-0095)
*	809-0098	Screw, 6-32 x 1¼-inch Slotted Round Head
*	809-0357	Screw, 6 x ⅜-inch Phillips Head NP
*	809-0359	Screw, 8 x ¼-inch Hex Washer Head
*	809-0360	Screw, 8 x ⅜-inch Hex Washer Slot Head
*	826-1371	Screw, 8 x ½-inch Hex Head ZP (Pkg. of 25) (809-0361)
*	809-0364	Screw, 8 x ⅝-inch Hex Washer Head ZP
*	809-0441	Screw, 8 x 1½-inch Hex Washer Head
*	809-0362	Screw, 8 x 1¼-inch Hex Washer Head Drill Point
*	809-0518	Screw, 8-32 x ⅜-inch Hex Washer Slotted Head SS
*	809-0104	Screw, 8-32 x ½-inch Slotted Head ZP
*	826-1363	Screw, 8-32 x ½-inch NP (Pkg. of 25) (809-0103)
*	826-1360	Screw, 10-24 x 5/16-inch Round Slot Head ZP (Pkg. of 25) (809-0024)
*	809-0123	Screw, 10-24 x 3/4-inch Slotted Truss Head
*	826-1330	Screw, 10-32 x ⅜-inch Slot Head SS (Pkg. of 25) (809-0117)
*	809-1003	Screw, 10-32 x ⅜-inch Hex Trim Head SS
*	809-0938	Screw, 10-32 x ⅝-inch Philips Truss Head
*	826-1375	Screw, 10-32 x ¾-inch Hex Trim Head SS (Pkg. of 5) (809-0401)
*	809-1000	Screw, 10-32 x 1¼-inch Hex Sck C/S
*	826-1374	Screw, 10 x ½-inch Hex Head (Pkg. of 25) (809-0412)
*	809-0266	Screw, 10 x ½-inch Phillips Head ZP

*continued on the following page*

## 2.15 Fasteners cont.

ITEM	PART #	COMPONENT
*	809-0500	Screw, 10 x 1/2-inch Hex Washer Head 410 SS
*	809-0434	Screw, 10 x 3/8-inch Hex Washer Head NP
*	809-0123	Screw, 10 x 3/4-inch Slot Head
*	826-1389	Screw, 1/4-20 x 3/4-inch Hex Head ZP (Pkg. of 10) (809-0131)
*	826-1346	Spacer, Ignition Module (Pkg. of 10)
*	810-2763	Spacer, Interface Board
*	826-1340	Spacer, .25-inch x 1.187-inch (Pkg. of 10)
*	810-0500	Spacer, .25-inch x .9375-inch
*	810-2023	Spacer, .25-inch x .110-inch (Used on drain valves.)
*	200-6721	Plate, Strain Relief
*	826-1337	Tab, 1/4-inch Terminal (Pkg. of 5)
*	807-0070	Terminal, Ground Lug
*	807-1948	Ty-Wrap
*	807-1359	Mount, Ty-Wrap
*	826-1383	Washer, 3/4-inch O.D. x 1/4-inch I.D. ZP (Pkg. of 5) (809-0435)
*	809-0582	Washer 1/2 NPT Locking
*	809-0184	Washer, #10 LK ZP
*	809-0190	Washer, .625 X .275 X 40 Flat SS
*	809-0191	Washer, Lock 1/4 Spring ZP
*	809-0193	Washer, Flat 1/4 Nylon
*	809-0194	Washer, Flat 5/16 ZP
*	809-0196	Washer, 3/8-inch Flat
*	810-1165	Washer, 3/8-inch Teflon



**FRYMASTER<sup>®</sup>**

*A Welbilt Brand*

**Frymaster, L.L.C., 8700 Line Avenue, Shreveport, Louisiana 71106**

**TEL 1-318-865-1711**

**FAX (Tech Support) 1-318-219-7135**

**PRINTED IN THE UNITED STATES**

**SERVICE HOTLINE  
1-800-551-8633**

**8196688  
02/2020**