



SIMPLESPEC

CONVEYOR PIZZA OVEN HOOD MODELS SSA-PIZZA

This is an exhaust only close proximity cap style conveyor oven ventilator specifically designed for maximum capture with minimum exhaust. Canopy is mounted no more than 1" above the oven so that the oven can be rolled in and out for ease of cleaning and service. This model is intended for use with all makes and models of electric and gas conveyor ovens. The SSA-PIZZA is designed as a Type I or Type II hood.

SHORT FORM SPEC: Avtec SSA-PIZZA series hood system for use over Conveyor Pizza Ovens. Includes stainless UL 710 Listed Hood, stainless steel filters, and removable grease troughs. Accessories to include auto start temp sensors prewired to connection box, 11"x11" stainless steel duct extension 96" long with welded hanging angles and ceiling trim ring on SSA-PIZZA24040, 30" tall duct enclosure with 4-piece chrome sleeve to cover hanger rod (rod by others) on all other models. Hood system designed for use conveyor pizza ovens, air flow sized to 75 CFM per deck on SSA-PIZZA24040, and 1000 CFM per deck on all other models.

AVAILABLE MODELS:

- SSA-PIZZA24040
- SSA-PIZZA32090
- SSA-PIZZA42098
- SSA-PIZZA42113
- SSA-PIZZA42128

STANDARD FEATURES:

- All 430 stainless steel construction
- UL Listed baffle style stainless steel grease filters
- 30" tall stainless steel duct enclosure (excludes model SSA-PIZZA24040)
- Chrome sleeve to conceal hanger rod (excludes model SSA-PIZZA24040)
- 96" tall stainless steel duct enclosure (model SSA-PIZZA24040 only)
- IMC 2006 auto start temp sensor fan delay interlock

SPECIFICATIONS: A single shell, direct draw cap style ventilator specifically designed to ventilate conveyor ovens. The canopy is constructed of stainless steel on all surfaces and aluminized steel on all non-exposed surfaces. Canopy is to meet NSF standards for construction and UL 710 standards for operation. Hood shall have fluid welded exterior joints and seams. Hood construction shall conform to NFPA 96 standards. All exposed welds are to be ground and polished to match finish requirements. Hanging brackets provided to hang hood no more than 1" above the oven. UL Listed stainless steel baffle style grease filters are located over both the loading and unloading ends of the oven and shall be easily removable for cleaning.

ORIGIN OF MANUFACTURE: Designed and manufactured in the United States.



PROJECT NAME:	
LOCATION:	
ITEM NO:	
QTY:	
MODEL NO:	
AIA NO:	
SIS NO:	
CSI SECTION:	11400

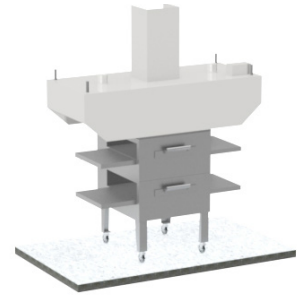

Model SSA-PIZZA3290 shown

ADDITIONAL RESOURCES:

- [Request A Quote](#)
- [Product Videos](#)
- [Sales Tools](#)
- [Find A Rep](#)

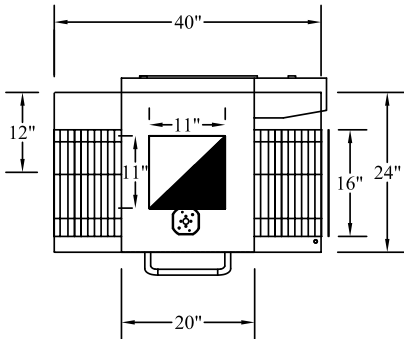

11" x 11" ID x 96" 18 TA S/S DUCT EXTENSION WITH PERIMETER CEILING FLANGE AND (4) 1-1/2" ANGLE HANGING BRACKETS LOCATED 6" FROM TOP OF DUCT, WELDED SOLID TO SUPPORT HOOD & DUCT

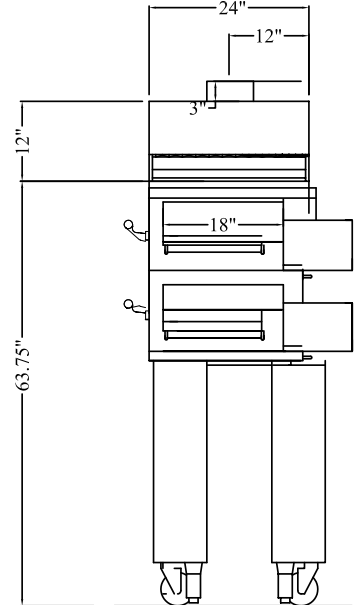
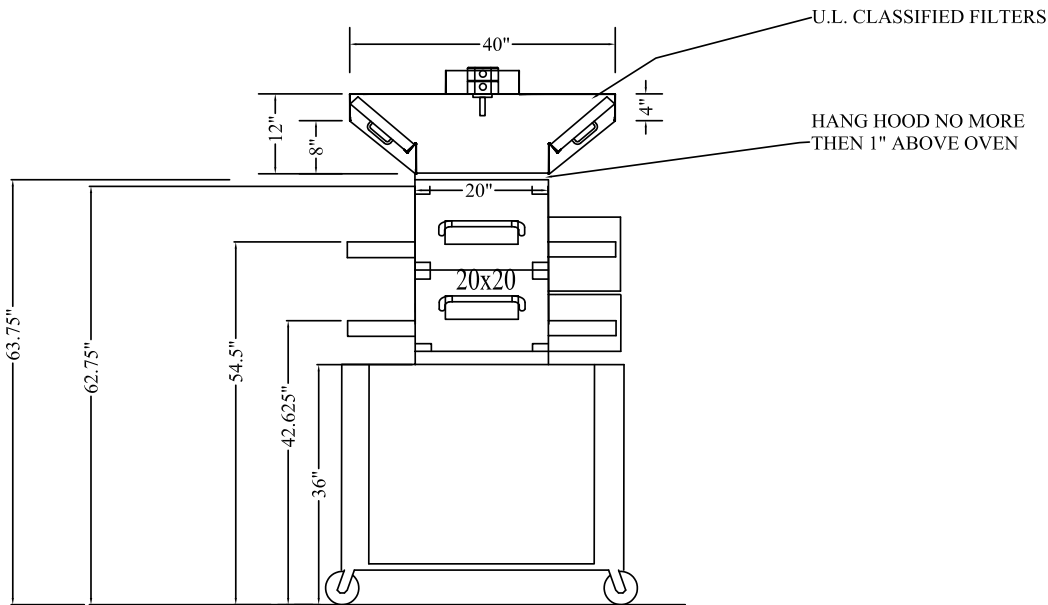
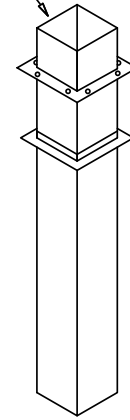

MODEL	SIZED FOR OVEN BAKING CHAMBER SIZE		HOOD SIZE (L X D X H)	CFM REQUIREMENT			COLLAR	SIZED FOR USE OVER MODELS
	LENGTH	DEPTH		SINGLE DECK	DOUBLE DECK	TRIPLE DECK		
SSA-PIZZA24040	20"	20-22"	40" x 24" x 12"	750	1500	-	(1) 11x11 @ 0.5SP	LINCOLN 1300, DCTI MIDDLEBY MARSHALL PS520 OVENTION 2000/2600