



Project \_\_\_\_\_  
 AIA # \_\_\_\_\_ SIS # \_\_\_\_\_  
 Item # \_\_\_\_\_ Quantity \_\_\_\_\_ C.S.I. Section 114000



## GTi Scale



GT Scale with 11.6" Operator Display



GT Scale with 10" Elevated Customer Display



## SPECIFIER STATEMENT

The GTi scale is equipped with a quad-core processor and Linux operating system. GT scales weigh, automatically compute a price from stored PLU's, and print a label. The GT scales utilize Hobart's multi-screen swipe technology user interface for operator ease of use. Scales on the same network may connect remotely to other scales for a Hand Wrap Station or other applications.

## MODELS

Model	Customer Display	Operator Display
<input type="checkbox"/> GTi-DB	No GCD	11.6"
<input type="checkbox"/> GTiP-DB	Printer Only	11.6"
<input type="checkbox"/> GTi-7DB	7" Integrated GCD	11.6"
<input type="checkbox"/> GTi-7EDB	7" Elevated GCD	11.6"
<input type="checkbox"/> GTi-10EDB	10" Elevated GCD	11.6"
<input type="checkbox"/> GTi-DC	No GCD	13.3"
<input type="checkbox"/> GTiP-DC	Printer Only	13.3"
<input type="checkbox"/> GTi-7DC	7" Integrated GCD	13.3"
<input type="checkbox"/> GTi-7EDC	7" Elevated GCD	13.3"
<input type="checkbox"/> GTi-10EDC	10" Elevated GCD	13.3"

## STANDARD FEATURES

- + Engaging and customizable graphical user interface
- + Capacitive touch display for optimal responsiveness
- + Durable touchscreen improves wear and tear properties
- + Optional operator display sizes (11.6", 13.3")
- + Change departments from the home screen
- + Auto-print capability from home screen
- + Customizable flash keys
- + Built-in wired or wireless connectivity
- + 5-screen swipe capability
- + Up to 3" label width
- + Low label detection and alerts
- + Advanced diagnostic alerts
- + Search by description, category, or PLU
- + Best seller keys by scale/department
- + On-screen operator manual and tutorial videos
- + Cassette label loading system for fast and efficient label changes
- + Hot swap print head and print roller for increased uptime
- + Support for UPC, EAN 13 & 128 barcodes, QR Codes, Datamatrix, and GS1 Databar
- + Track operator and supervisor changes
- + Remote access with Hobart software

## SOFTWARE

- + Linux embedded operating system 
- + Interfaces with scale management software such as:
  - Invafresh
  - Upshop
  - Hobart HCT
  - Hobart HTe Enterprise
    - Content management
    - Label editing
    - Remote updates

GT SCALE SERIES – GTi

Approved by \_\_\_\_\_ Date \_\_\_\_\_ Approved by \_\_\_\_\_ Date \_\_\_\_\_

## TECHNICAL SPECIFICATIONS

- + 11.6" or 13.3" Capacitive Touchscreen
- + 7" integrated customer display
- + Optional 7" or 10" elevated customer display
- + Quad-core processor
- + 2 GB DDR3 RAM Memory
- + 32 GB micro SD RAM standard
- + 8 ips print speed
- + Bluetooth BLE 5.0
- + WiFi-6, and WPA3 security encryption
- + Two external USB 3.0 ports
- + High resolution thermal printhead for detailed graphics (store logos) and smaller barcodes - 203 dpi (8 dots per mm)
- + Accepted labels:
  - 1.50" to 3.00" width
  - 1.00" to 9.50" long die cut
  - Continuous labels
  - Oval labels
  - Linerless (optional)

## DETAILS AND DIMENSIONS

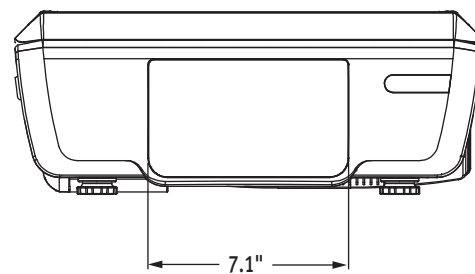
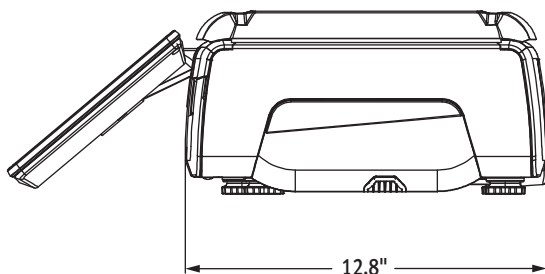
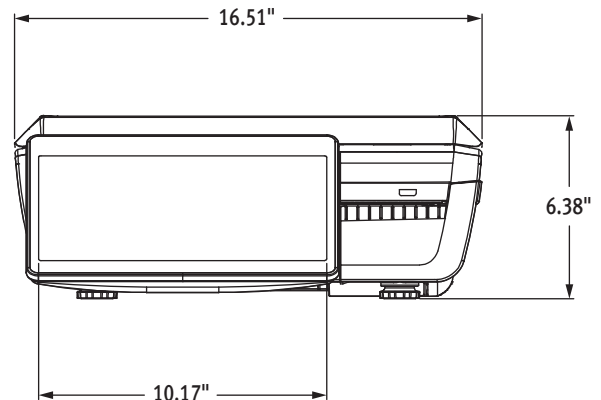
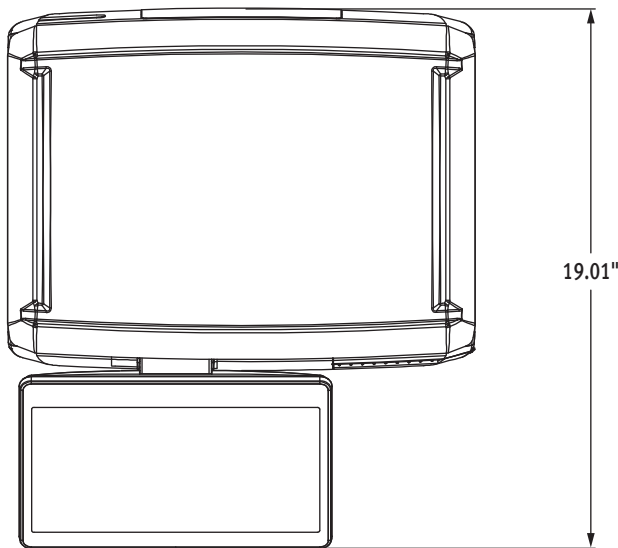

GT 11.6" Operator Display, 7" Integrated Customer Display

## SPECIFICATIONS

**Platter:** 16.5" wide x 12" deep

**Weigher Capacity:**

0 lb. - 12 lb. x 0.005 (0-6 kg x .002 kg)

12 lb. - 30 lb. x 0.01 (0-15 kg x .005 kg)

**Pricing Capacity:** Up to 999.99 in steps of .01

**Electrical:** 100-240 volts, 50-60 Hz, single phase, 1.42 amps, 170 watts max. 9 foot standard cord cap with ground type plug furnished.

**Media Supports:** MPEG4, AAC, AVC/H.264

**Weights and Measures Certification:**

- + USA Certification – 23-095
- + Canada Certification – Pending

**Environment:** Operating temperature limits are 14°F (-10°C) to 104°F (40°C) ambient. Scale operates satisfactorily in relative humidity of 10 to 85%.

**Shipping Weight:** 34 lbs.

## ACCESSORIES

- PLATTER-FISH-GT – Fish pan replaces standard scale platter in seafood departments

## DETAILS AND DIMENSIONS

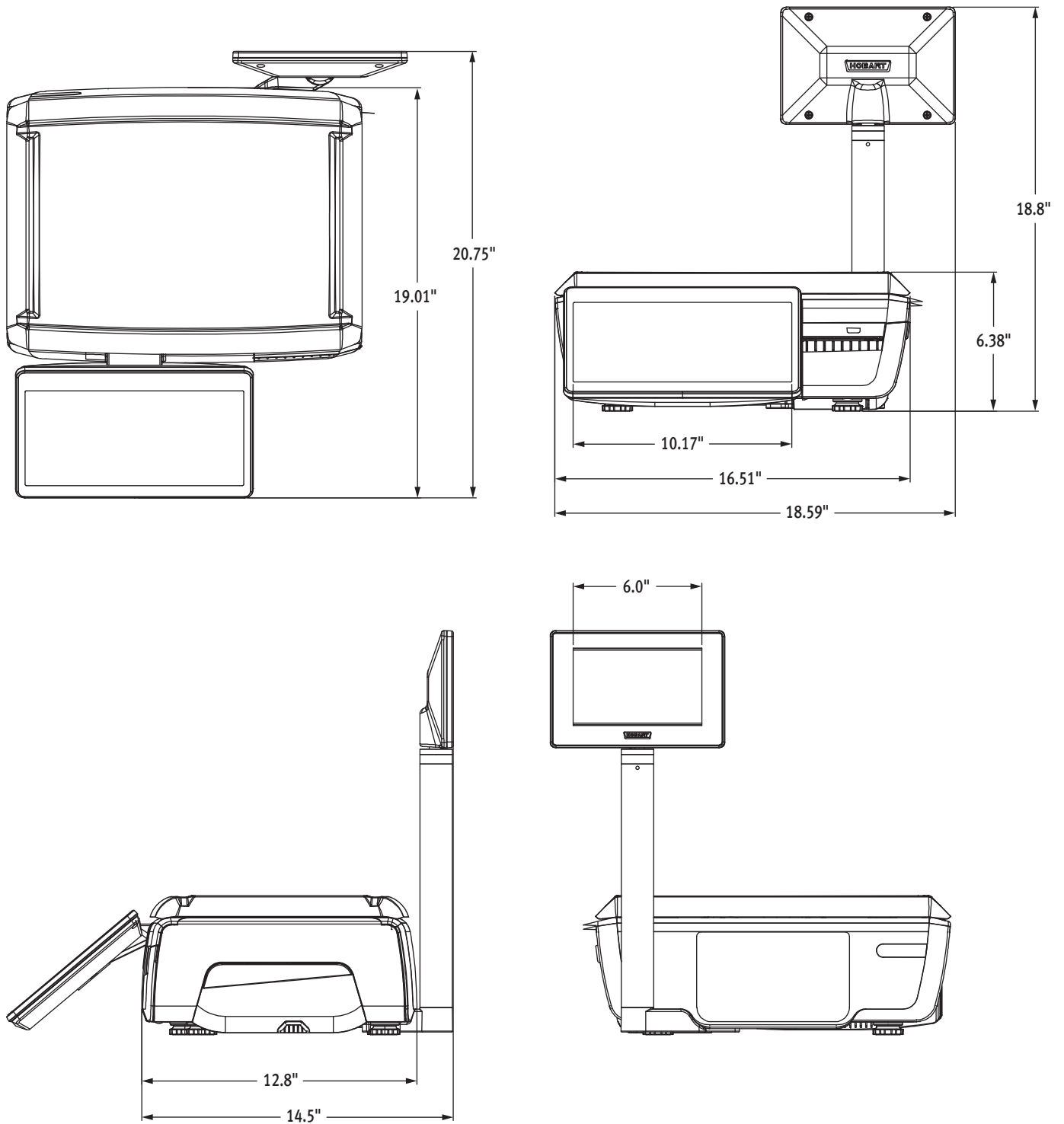

GT 11.6" Operator Display, 7" Elevated Customer Display

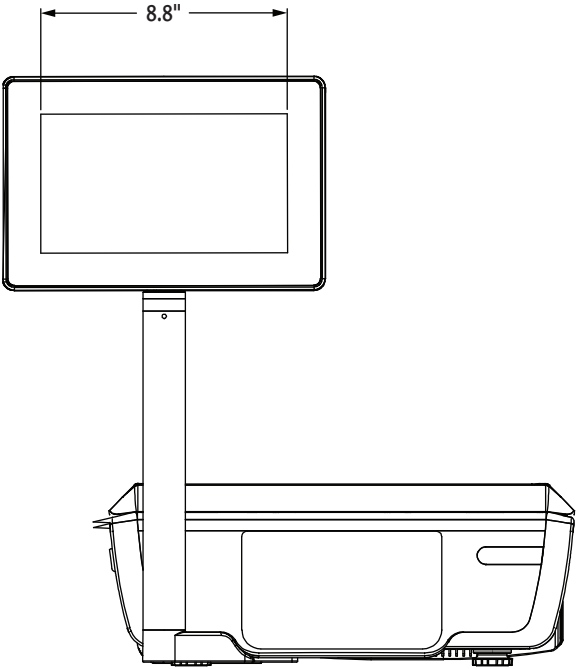
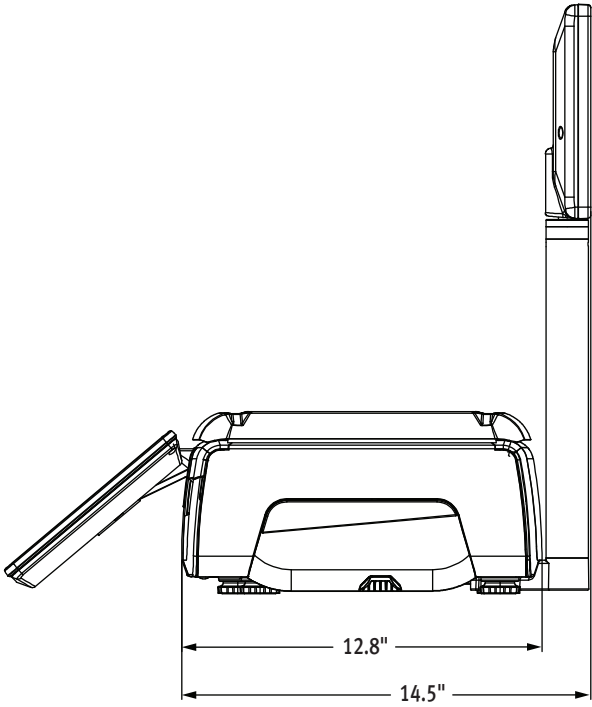
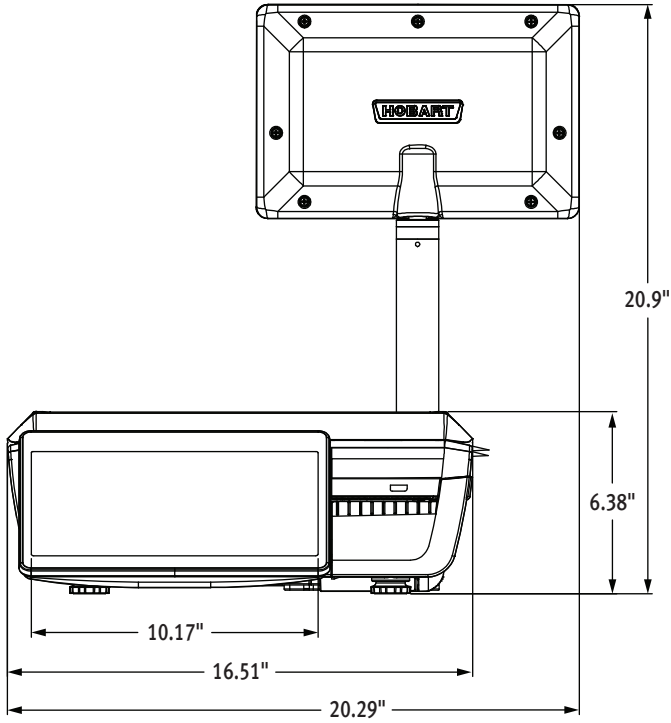
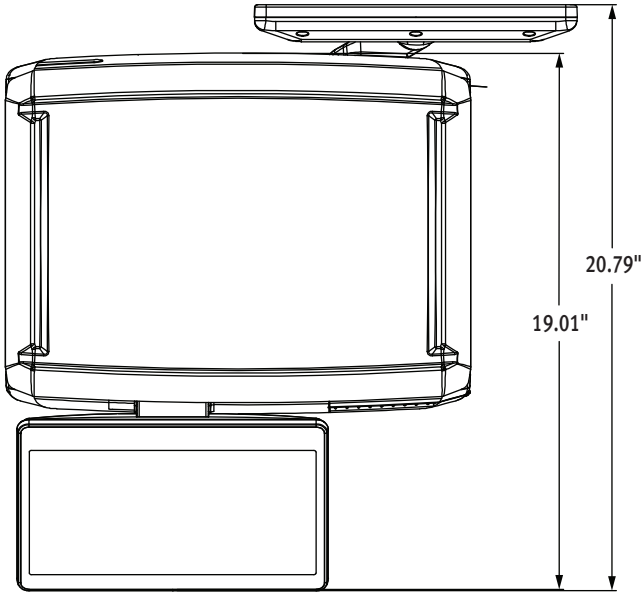

GT 11.6" Operator Display, 10" Elevated Customer Display

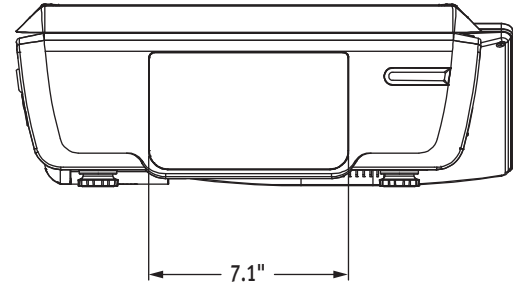
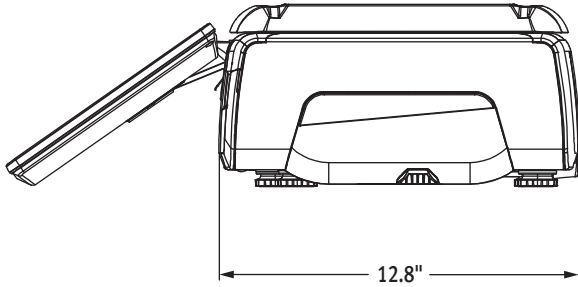
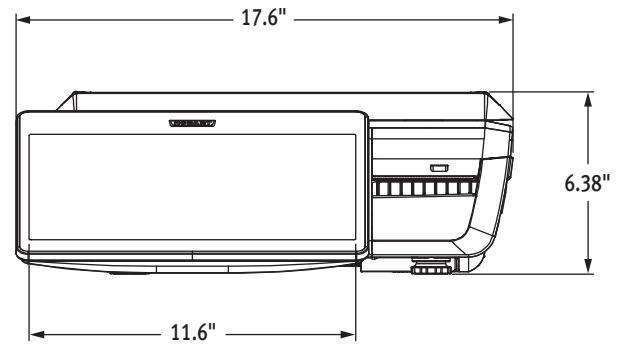
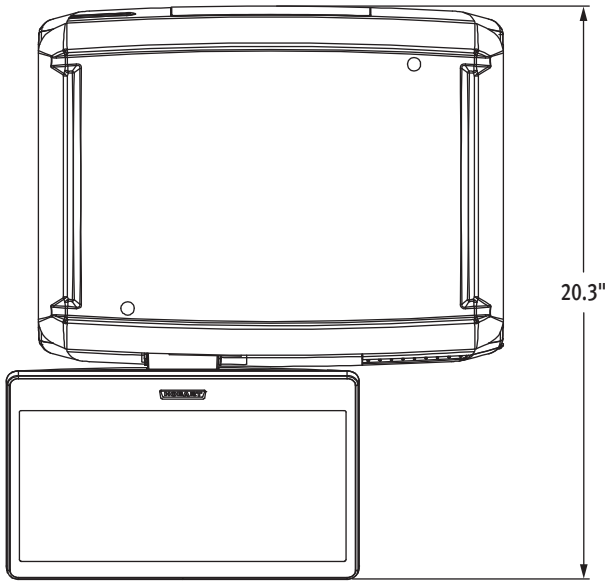

**GT 13.3" Operator Display, 7" Integrated Customer Display**

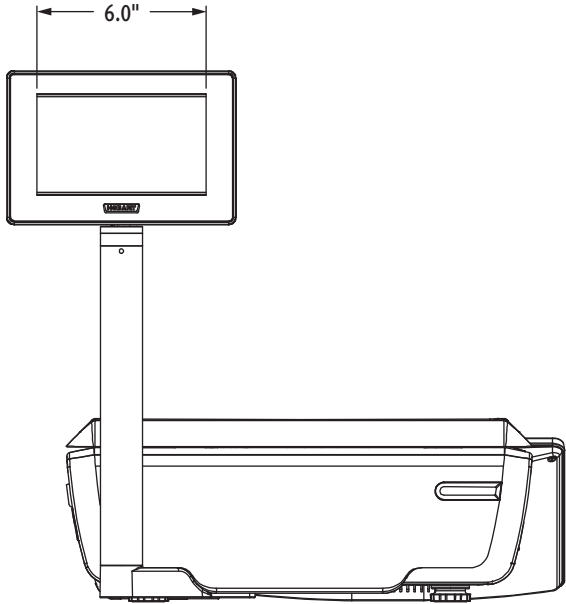
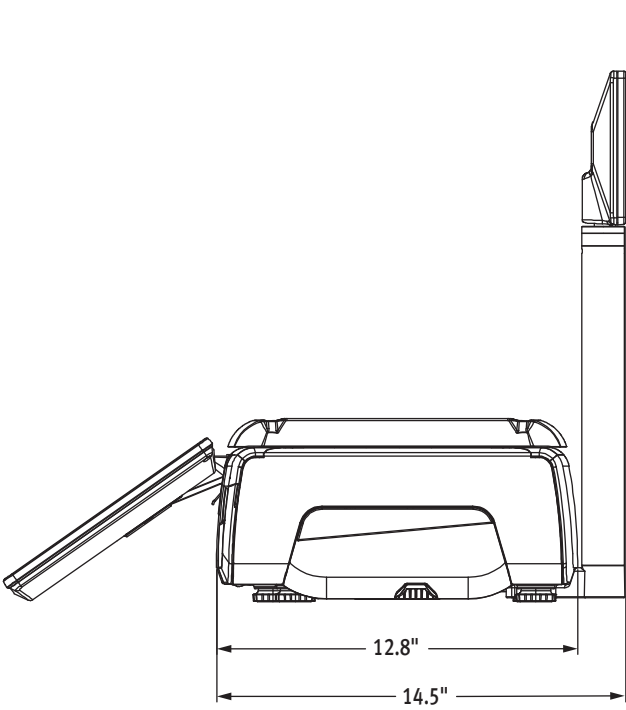
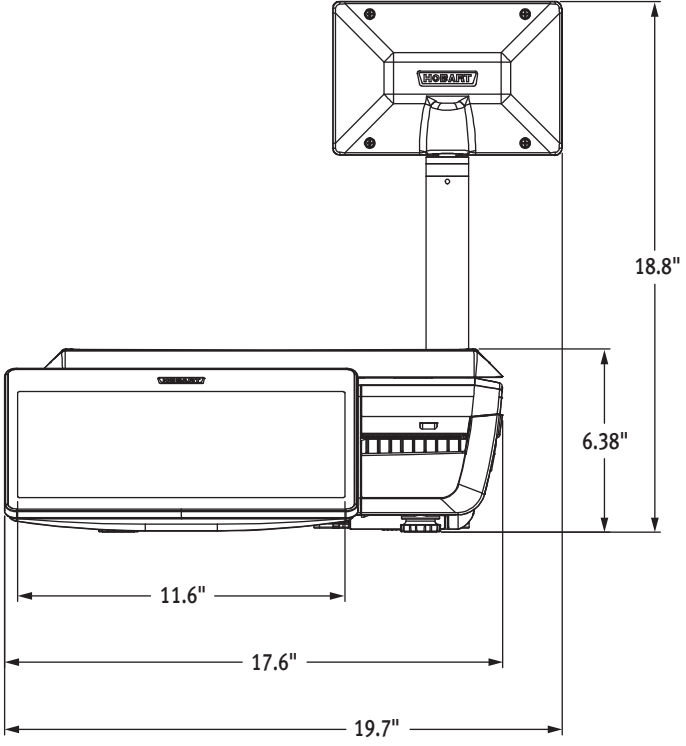
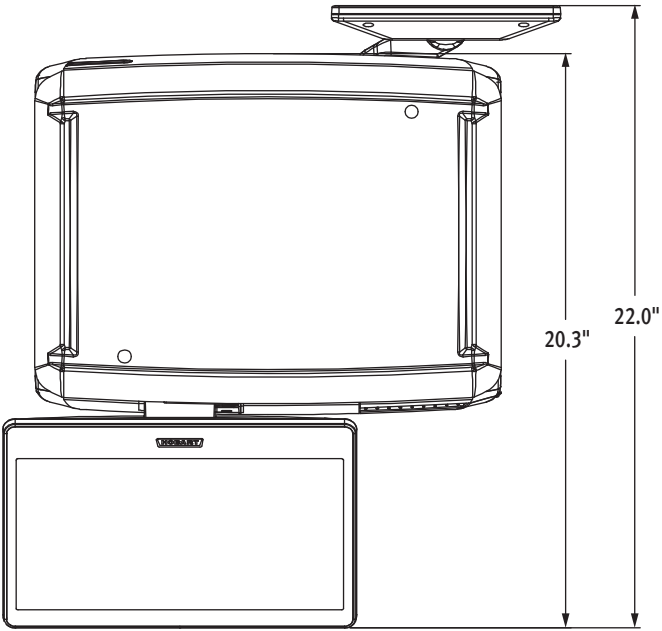

GT 13.3" Operator Display, 7" Elevated Customer Display

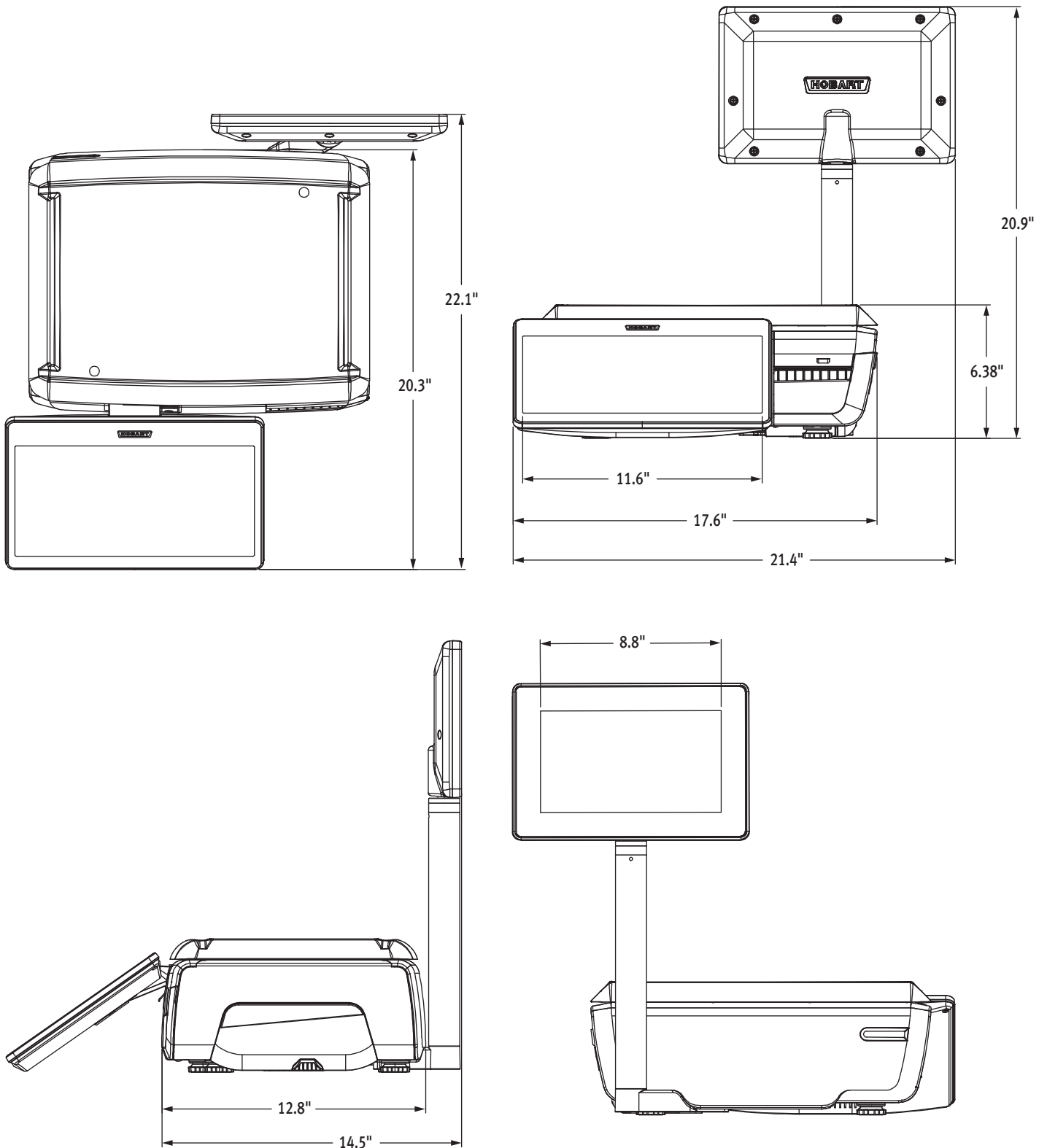

**GT 13.3" Operator Display, 10" Elevated Customer Display**

As continued product improvement is a policy of Hobart, specifications are subject to change without notice.