



BEVERAGE-AIR

Project: _____	AIA#
Item: _____	
Location: _____	SIS#
Approved: _____	

PFI2XTHC TOP MOUNT EXTRA TALL ROLL-IN FREEZER

P SERIES TOP MOUNT EXTRA TALL ROLL-IN FREEZER

PFI2XTHC-1AS Solid Door Roll-In Freezer

Hydrocarbon Series

MODEL:
PFI2XTHC-1AS



7 Year Parts/Labor Warranty
7 Year Compressor Warranty

CABINET CONSTRUCTION

- Stainless steel front and side exterior (galvanized rear, back & bottom)
- Interior liner is made of corrosion resistant aluminum
- Stainless steel door liner
- Full electronic control
- Expansion valve technology
- Self-closing door with 120° stay-open feature
- 22 Gauge stainless steel door
- LED interior light
- Heavy-duty cylinder locks
- Snap-in magnetic gaskets for positive door seal
- Hinged front shroud
- Reinforced stainless steel door ramps outside and cart guides inside
- Accepts carts up to 26 3/8"(W) x 26"(D) x 72 1/2"(H) (cart not included)
- Wiper gasket at bottom of door seals door to ramp
- Energy saving thermal breaker
- Stainless steel breaker caps
- 8' Cord and plug (see electrical data for details)

OPTIONS & ACCESSORIES

- Stainless steel interior
- Stainless steel back
- Door swing orientation (at time of order)

REFRIGERATION SYSTEM

- Uses environmentally friendly, energy efficient R290 refrigerant, and meets all regulatory requirements for CARB, SNAP, DOE & more
- Adaptive defrost
- Epoxy coated evaporator coil, located out of the food zone
- Freezer capable of maintaining product temperature down to -10°F



Please verify qualifying units by visiting:
www.energystar.gov/cfs

3779 Champion Blvd., Winston-Salem, NC 27105
1-888-845-9800 Fax: 1-336-245-6453
Beverage-Air.com Sales@bevair.com



BEVERAGE-AIR®

MODEL	PFI2XTHC-1AS
EXTERNAL DIMENSIONAL DATA	
Width Overall	68 7/8"
Depth Overall with Handle	36 1/4"
Height Overall	89 7/8"
Number of Doors	2
Depth with Door Open 90°	65 3/4"
Door Openings (in)	27 7/8" x 72"
INTERNAL DIMENSIONAL DATA	
NET Capacity (cubic ft.)	77.35
Internal Width Overall (in)	63 5/8"
Internal Depth Overall (in)	26"
Internal Height Overall (in)	73"
ELECTRICAL DATA	
Full Load Amperes 115/60/1*	13.9
REFRIGERATION DATA	
Horsepower	(2) 3/4
Capacity (BTU/Hr)	4900
Heat Rejection (BTU/Hr)	7350
Charge (lbs/grams/ounces)	0.2866 / 130 / 4.6
SHIPPING DATA	
Gross Weight - Crated	750 lbs
Height - Crated	95"
Width - Crated	45"
Depth - Crated	78"

We reserve the right to change specifications and product design without notice. Such revisions do not entitle the buyer to corresponding changes, improvements, additions or replacements for previously purchased equipment. Dimensional tolerances +/- 1/4". Metric dimensions (MM).

P Series Top Mount Roll-In Extra Tall Freezer Model: PFI2XTHC-1AS

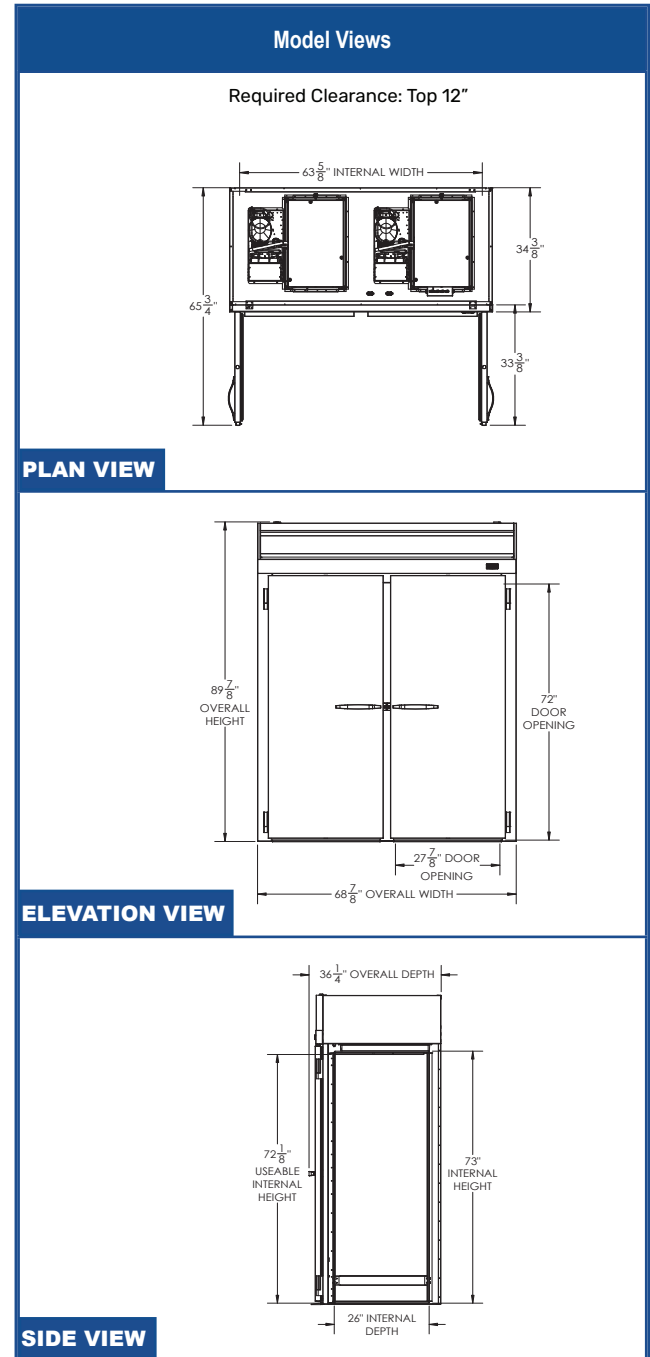

ELECTRICAL CONNECTION



115/60/1*
NEMA 5-15P

Unit pre-wired at factory
and include 8' long cord
and plug set.

* NOTE: Units that utilize variable speed compressor technology can experience nuisance tripping on Class A GFCI outlets which have a trip limit of 4 to 6 mA. To avoid this issue in a location that requires GFCI circuit protection, Beverage-Air recommends using either an Eaton, SCF20, or HUBBELL Model Number GFRST83W 20A Heavy Duty Hospital Grade Self-Test GFCI Receptacle.

