



MAXIMUM-CAPACITY ROTISSERIE - PASS-THROUGH -  
TOUCHSCREEN CONTROLS - FLAT GLASS

# VGG-16-F-PT



Ideal for extremely high-volume supermarkets and restaurants, the BKI® VGG-16-F-PT has a massive cooking capacity that will meet growing customer demand and improve profitability. The VGG-16-F-PT is a pass-through rotisserie, allowing the back of the kitchen to load raw product and the front kitchen to pull cooked product, thus reducing the risk of contamination.

This double stack of rotisseries can cook up to up to 80 3-lb (1.36 kg) chickens in 75 minutes. The results are delicious—moist and tender inside and perfectly golden brown outside.

The bright touchscreen display makes operation a breeze with true one-touch cooking. Store up to 15 customizable menu programs that can be locked to protect important settings. Select English or Spanish with the new bilingual feature.

Innovative safety features include cool-door technology and sensors that stop rotation when the door is opened.

Whether poultry, pork, beef, vegetables, or your own specialty, the VGG-16-F-PT is sure to maximize customer satisfaction and produce uniform, consistent results every time.

## FEATURES AT A GLANCE

- Touchscreen controls
- Lighted cavity to attract customer attention
- 15 program modes with pre-heat and hold capability
- Cool door for safety
- Pass-through design
- 100% hand built in the U.S.A..



### PRODUCT CAPACITY

Cooks up to 80 3-lb (1.36 kg) chickens in 75 minutes at the touch of a button.



### ELECTRIC OPERATION

Energy efficiency and easy installation are a perfect pairing for your food service operation.



### TOUCHSCREEN CONTROLS

True one-touch process controls ensure menu items are perfectly cooked.



### COOL-DOOR SAFETY

Double doors insulate to prevent burns; sensors stop rotation and cooking when door is opened.

[www.bkideas.com](http://www.bkideas.com)

42 Allen Martin Drive, Essex Junction, VT 05452 • Phone: (802) 658-6600 • Fax: (802) 864-0183

BK1281 Rev C (2/23)

## EQUIPMENT DIMENSIONS

DIMENSION ARE IN INCHES [MM]

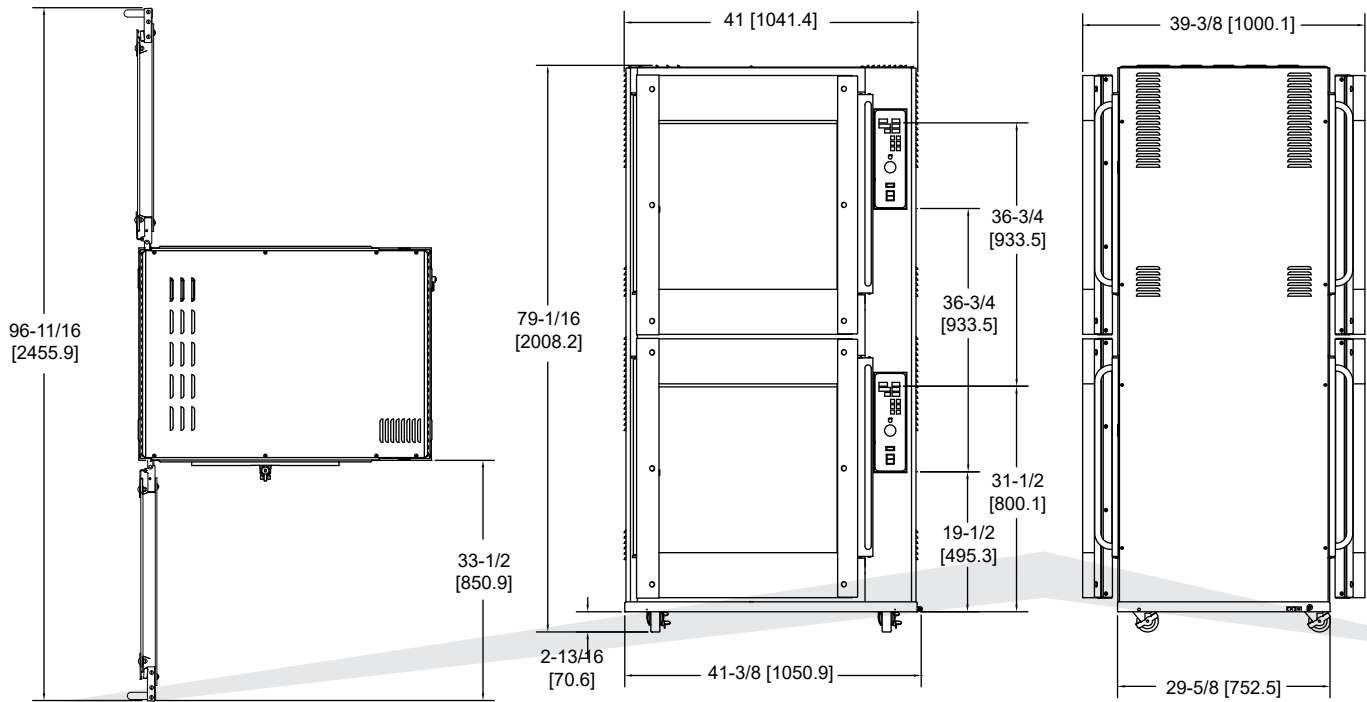

## MECHANICAL SPECIFICATIONS

Dimensions	Uncrated	Crated
Height	79 1/16" (2008.2 mm)	88" (2239.2 mm)
Width	41 3/8" (1050.9 mm)	47" (1195.9 mm)
Depth	39 3/8" (1000.1 mm)	45.5" (1157.8 mm)
Floor space	10.6 sq ft (.98 sq m)	14.9 sq ft (1.38 sq m)
Weight	947 lb (429 kg)	982 lb (445.4 kg)

## ELECTRICAL OPTIONS

Volts	Hz	Amps	Breaker	kW	Phase	Wires
208	50/60	29.7	40	10.6	3	3+GND
220	50/60	26.4	35	9.9	3	3+GND
240	50/60	28.7	40	11.8	3	3+GND
380/220	50/60	15	20	9.3	3 w/ N	4+GND
400/230	50/60	15	20	10.2	3 w/ N	4+GND
415/240	50/60	16	20	11.1	3 w/ N	4+GND

\* Ratings per oven cavity; separate power supply required for each cavity.

## OPTIONS

- Solid back
- Curved glass
- Drain on drip pan
- Controls on the left



Visit [www.bkideas.com](http://www.bkideas.com) to view all accessories available with this model.