

Empura®

EKB27R

Reach-In Bottom-Mount Refrigerator



Features

- CFC free refrigerant and foam insulation
- Electronic thermostat and digital LED temperature display for accurate control and easy reading
- 3 adjustable, heavy-duty epoxy coated wire shelves per door
- Condensate heating element built into condensate pan for efficient evaporation of excess water
- Easy to mount 4" casters (lockable in front) are standard with all units
- Locking doors on all units. EKB27R door swing is field reversible
- Self-closing doors that remain open at 90 degrees
- Magnetic gasket can be replaced without any tools
- Exterior: 430 stainless steel, door & front panel: 202 stainless steel.
- Interior: 304 stainless steel
- Temperature: 33 to 41°F / 0.5 to 5°C
- Electrical: 115/60/1 with NEMA 5-15P plug

Warranty: 2-Years Parts & Labor, 5 Years on Compressor

MODEL	DOORS	EXT DIMENSIONS W x D x H	INT. DIMENSIONS W x D x H	AMPS	H.P.	SHIP WEIGHT
EKB27R	1	26.8 x 32.7 x 82.3	22.2 x 27.6 x 50.2	6	3/8	307 lbs

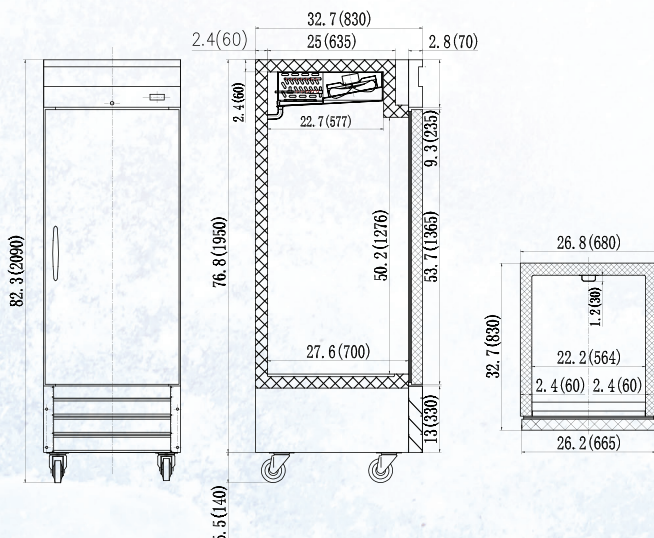

CERTIFIED TO ANSI/
NSF-7 STANDARDS