

Project: _____

Item: _____

Quantity: _____

Equipment Stand - Modular

Designed to hold heavier equipment that doesn't have its own legs or base such as griddles, broilers, ovens and steamers. These stands are shorter than work tables, so the equipment they hold will sit at a comfortable working height. Top and undershelf have raised marine edges to provide a secure resting area for equipment so it's less likely to slip or slide off.

Optional 5" stem type casters allow the stands to easily be wheeled around to different parts of the kitchen and stored away when not in use. This is particularly helpful if you find yourself using equipment on a seasonal basis or only during certain times of the week. It's also great for allowing multiple work stations to use a single piece of equipment, like a mixer or slicer.

- Ships "KD" (knocked down) for easy assembly with Allen wrench (included).
- One-Year Guarantee against material defects and workmanship.
- Lifetime Guarantee against rust and corrosion.



21524ES24P

21524ES24PC

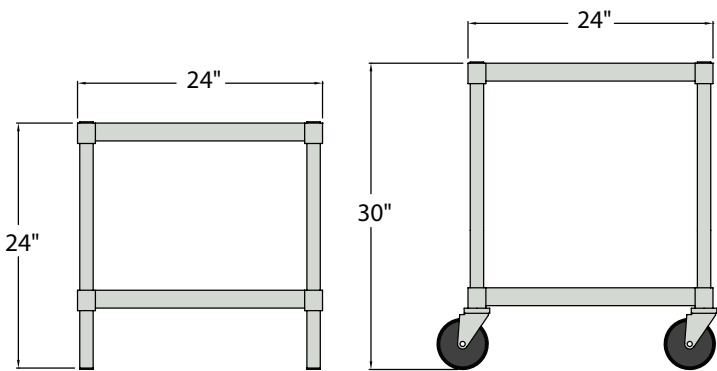

21524ES24P

21524ES24PC

▶ Modular Aluminum Equipment Stands

Model No	Size D-H-L	Ship Lbs	Model No	Size D-H-L	Ship Lbs.	Model No	Size D-H-L	Ship Lbs.
21524ES24P	15" x 24" x 24"	15	21524ES30P	15" x 30" x 24"	17	21524ES36P	15" x 36" x 24"	17
21530ES24P	15" x 24" x 30"	22	21530ES30P	15" x 30" x 30"	19	21530ES36P	15" x 36" x 30"	20
21536ES24P	15" x 24" x 36"	19	21536ES30P	15" x 30" x 36"	20	21536ES36P	15" x 36" x 36"	21
21542ES24P	15" x 24" x 42"	20	21542ES30P	15" x 30" x 42"	21	21542ES36P	15" x 36" x 42"	22.5
21548ES24P	15" x 24" x 48"	23	21548ES30P	15" x 30" x 48"	24	21548ES36P	15" x 36" x 48"	25
21824ES24P	18" x 24" x 24"	17	21824ES30P	18" x 30" x 24"	18	21824ES36P	18" x 36" x 24"	19
21830ES24P	18" x 24" x 30"	19.5	21830ES30P	18" x 30" x 30"	20.5	21830ES36P	18" x 36" x 30"	22
21836ES24P	18" x 24" x 36"	22	21836ES30P	18" x 30" x 36"	22.5	21836ES36P	18" x 36" x 36"	24.
21842ES24P	18" x 24" x 42"	23.5	21842ES30P	18" x 30" x 42"	24.5	21842ES36P	18" x 36" x 42"	25.5
21848ES24P	18" x 24" x 48"	27.5	21848ES30P	18" x 30" x 48"	28.5	21848ES36P	18" x 36" x 48"	29.5
22024ES24P	20" x 24" x 24"	20	22024ES30P	20" x 30" x 24"	21	22024ES36P	20" x 36" x 24"	22
22030ES24P	20" x 24" x 30"	22	22030ES30P	20" x 30" x 30"	23	22030ES36P	20" x 36" x 30"	24
22036ES24P	20" x 24" x 36"	25.5	22036ES30P	20" x 30" x 36"	24.5	22036ES36P	20" x 36" x 36"	25
22042ES24P	20" x 24" x 42"	25.5	22042ES30P	20" x 30" x 42"	26	22042ES36P	20" x 36" x 42"	27
22048ES24P	20" x 24" x 48"	31	22048ES30P	20" x 30" x 48"	28.5	22048ES36P	20" x 36" x 48"	33

Options:

Casters (4): Add "C" suffix to model #.

– Four 5" stem type casters with brake.

Note: This option adds 6" to the overall height of the unit.



New Age Industrial Corp., Inc. || NewAgeIndustrial.com || Made in the USA

PO Box 520 • 16788 US Hwy 36 • Norton, Kansas 67654 || Phone: (800) 255-0104 • (785) 877-5121 || Fax: (877)-877-7687 • (785) 877-2616

This information is for general sales and engineering use only. New Age Industrial reserves the right to modify or make changes at any time, without notice, to materials and specifications.