

# SHALLOW DEPTH BASE MODEL FREEZER

## Model: FA43SNBS

Natural Refrigerant R-290 Model

43" Shallow Depth Base Model  
Freezer with Solid Doors & 5.5" Backsplash

Heavy gauge #300 Series stainless steel top, stainless steel front and end panels, galvanized steel rear and grill and aluminum interior.



## Options and Accessories

(upcharge and lead times may apply)

Stainless steel interior	Condensing unit left (standard on right)
Stainless steel back	Door & Drawer Locks
Overshelves (single or double)	Front Breathing
Stainless steel shelves	Adjustable legs
Additional epoxy coated steel shelves	Drawers in lieu of doors**
Drawer in lieu of door section above the condensing unit*	

Consult factory for other model configurations, options and accessories.

\*Drawer section above condensing unit holds (4) 1/6 pans

\*\*Two tier (larger section): (1) 12 x 20 x 6 pan per drawer

**Continental**<sup>®</sup>  
Refrigerator



Project Name:

Model Specified:

Location:

Item No:

Quantity:

AIA #:

SIS #:

## Standard Model Features

### REFRIGERATION SYSTEM

Performance rated refrigeration system

Environmentally safe R-290 refrigerant

Unique forced air design utilizes fans (approx. every 12") across the entire back of unit for even distribution of cold

Automatic, energy saving, non-electric condensate evaporator

Non-corrosive, plasticized fin evaporator coil

Expansion valve system

Easily serviceable, slide out condensing unit

### CABINET ARCHITECTURE

2" non-CFC polyurethane foam insulation

Spring loaded, self closing doors

Magnetic snap in Santoprene™ door gaskets

Heavy duty, epoxy coated steel shelf

Smooth, polished chrome door handles

Completely enclosed, vented and removable rear and side grills

5" Casters

### MODEL FEATURES

Electronic control, automatic electric defrost

Refrigerated section with door above the condensing unit

Field rehingeable doors

<sup>1</sup> R-290 refrigerant meets all federal and state regulatory requirements.

**NOTE:** Models come standard with a door over the condensing unit. A drawer over the condensing unit is an option.

APPROVAL:

# Model Specifications

## DIMENSIONAL DATA

Net Capacity (cubic feet)	9.6 (272 cu l)
Width, Overall (inches)	43 (1092mm)
Depth, Overall (inches) (including handles & bumpers)	31 (787 mm)
Height, Overall (inches) (including 5" casters)	40.5 (1029 mm)
Shelf Area (square feet)	4.5 (0.42 sq m)
Number of Shelves	2
Number of Full Doors	1
Number of Half Doors	1
Interior Depth (inches)	24 (610 mm)
Interior Height (inches)	26 (660 mm)
Interior Height (inches) (above condenser)	12 1/2 (318 mm)

## REFRIGERANT DATA

Condensing Unit Size (H.P.)	1/3+
Capacity (BTU per hour)*	1340

## ELECTRICAL DATA

Voltage (International)	115/60/1 (220/50/1)
Total Amps (International)	4.3 (2.7)
Defrost Amps (International)	6.5 (3.4)
10 ft. Cord/Plug [attached] (International)	Yes (No)

## SHIPPING DATA

Weight (pounds)	265 (120 kg)
Height - Crated (inches)	43 3/4 (1111 mm)
Width - Crated (inches)	45 (1143 mm)
Depth - Crated (inches)	47 (1194 mm)

\* Rating @ -15°F evaporator, 90°F ambient  
 Figures in parentheses reflect metric equivalents rounded to the nearest whole unit.



Equipped with one NEMA-5-15P Plug  
 (varies by country)

# Model Plan Views

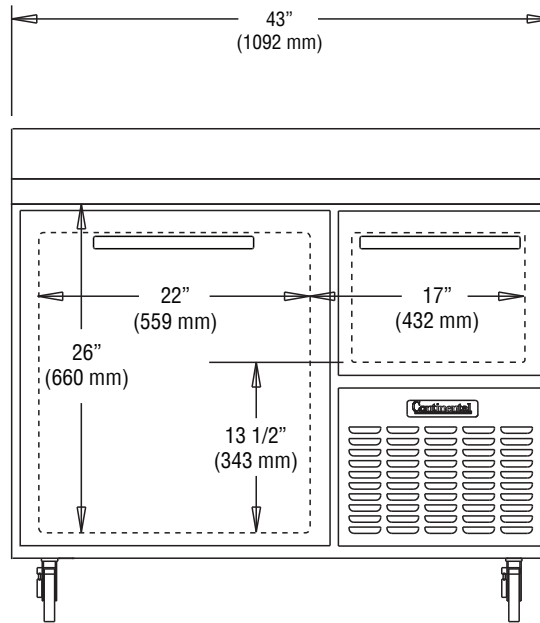

FRONT VIEW

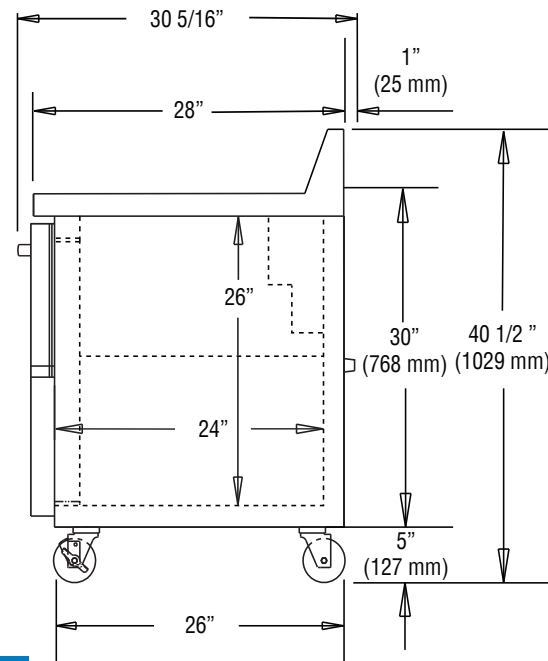

SIDE VIEW

**Continental**  
 Refrigerator

Toll-Free: 800-523-7138  
 Phone: 215-244-1400  
 Fax: 215-244-9579

539 Dunksferry Road  
 Bensalem, PA 19020  
[www.continentalrefrigerator.com](http://www.continentalrefrigerator.com)

Due to our continued efforts in developing innovative products, specifications subject to change without notice.



PROUDLY  
 DESIGNED & ASSEMBLED  
 IN THE U.S.A.