

DXP618-N

When empty, Nesting Racks fit together like a puzzle to save valuable floor space.

Dinex Nesting Racks offer a clever, workable solution to the problem of finding storage for empty racks. The unique Nesting Frame design provides sturdy easy access racks that, when empty, nest snugly within the footprint of one another, reducing multiple rack storage space.

One person can now move multiple empty racks. The Frame interlocks, holding the Racks together while they are moved through your facility.

For more than 40 years Dinex has manufactured food transport equipment for the bakery and food service industries. Dinex is proud to have the highest standards in the industry.

### STANDARD FEATURES

- Space Saving
- Easy Maneuverability of Multiple Racks
- 18" x 26" sheet pans

### MODEL NUMBER

- DXP618N

### DIMENSIONS

- H63" x W21" x D27"

### NESTING FRAME

- Allows multiple racks to nest together
- Reinforced with fully welded c-channel for strength
- Adds rigidity and stability to rack
- Efficient use of space

### STURDY TRAY SUPPORTS

- .080" thick aluminum extruded glides
- 1" x 2" ledge angles for versatility and strength
- Welded on front and back

### SUPERIOR CORNER SUPPORTS

- Extruded three-sided channel support
- .063", 1" x 1" aluminum tube bracing provide superior strength

### HEAVY-DUTY CASTERS

- 5" x 1-1/4" sealed wheel stem casters
- Delrin bearing, each with 350 lbs. capacity
- Maximum resistance to chemicals, acids, bases, alcohol, water and steam
- Maximum low temperature flexibility for superior performance, even in freezing temperatures

### WARRANTY

- One year parts and labor. Warranty is detailed on inside front cover of the price list.

We do not accept returns on any Dinex equipment or Dinex custom products. Please contact your local Dinex rep to ensure order accuracy prior to ordering.

# Nesting Racks

## Aluminum

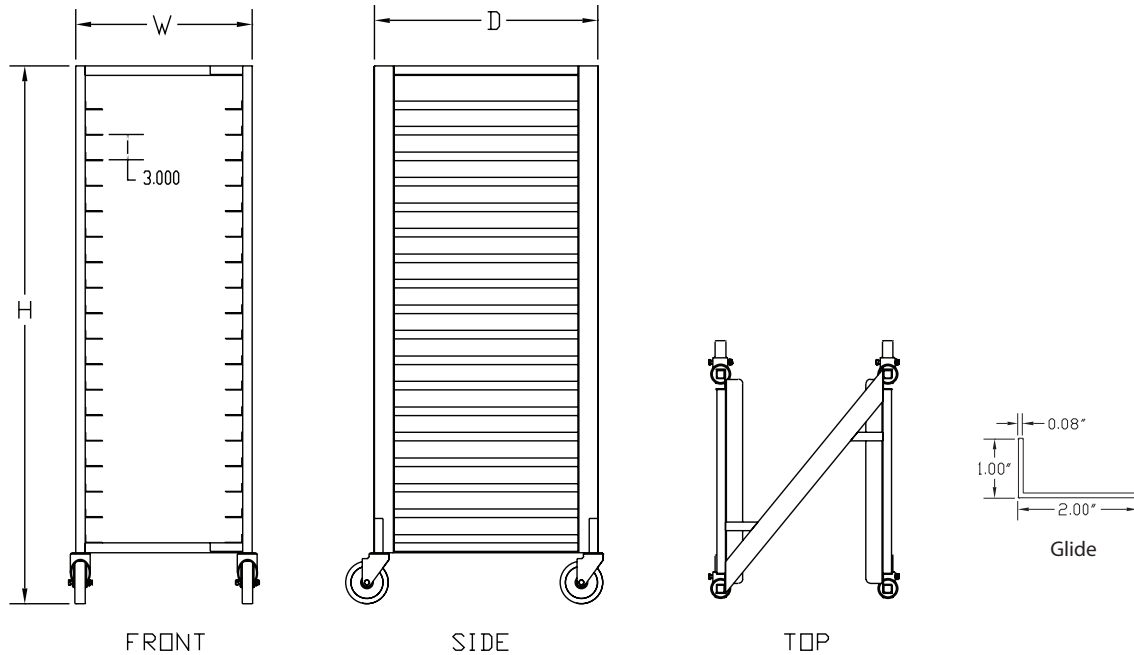

Model#	Description	Height Inches	Width Inches	Depth Inches	Channel Ht. Inches	Pan Capacity	Ship Wt. (lbs)
DXP618N	Nesting, end load	63"	21"	27"	3"	18	80

Custom height sizes and glide spacing available.  
 Height includes casters.  
 Approximate box dimensions: 64" x 23" x 29"  
 Typical freight class: 150

### RACKS OPTIONS / ACCESSORIES PART NUMBER

Option	Description
<input type="checkbox"/> DXPEMB	Personalized Embossment (12 letters per line)
<input type="checkbox"/> DXPY5	5" Polyurethane Casters (set of 4)
<input type="checkbox"/> DXPWB	Wheel Brakes (set of 2)
<input type="checkbox"/> DXPV	Vertical Bumpers

I-11 SPEC

**DINEX**  
www.dinex.com

4711 E. Hefner Road  
 Oklahoma City, OK 73131  
 800.654.8210  
 405.475.5600

**LIMITED WARRANTY:** DINEX warrants to the original purchaser parts and labor for a period of twelve (12) months from the date of purchase. See manufacturer's complete warranty for details.

It is our policy to build equipment which is design certified by companies that have been accredited at the Federal Level by the Occupational Safety and Health Agency (OSHA) and ANSI as a National Recognized Testing Laboratory. These companies include CSA International, Underwriters Laboratories, and the National Sanitation Foundation. However, a continuing program of product improvement makes it necessary to submit new models to the agencies as they are developed. Consequently, all models may not bear the appropriate labels at all times.

We reserve the right to change specifications and product design without notice. Such revisions do not entitle buyer to corresponding changes, improvements, additions or replacements for previously purchased equipment. Information is not for design purposes.