

Reveal[®]

USER MANUAL

SCC P/N
20-88453

REVEAL[®] FREE STANDING SELF-SERVICE DRY (AMBIENT) MERCHANDISERS

- > SOLID BACK PANELS OR REAR SLIDING DOORS
- > **CAUTION! DO NOT PUSH OR PULL ON END PANELS!**
- > **ONLY USE HANDLES (AT EACH END OF CASE) TO PUSH OR PULL CASE INTO POSITION!**
- > SEE PAGE 9-10 FOR FRONT PANEL, SIDE CLADDING, REAR PANEL & TOE-KICK ATTACHMENT GUIDE

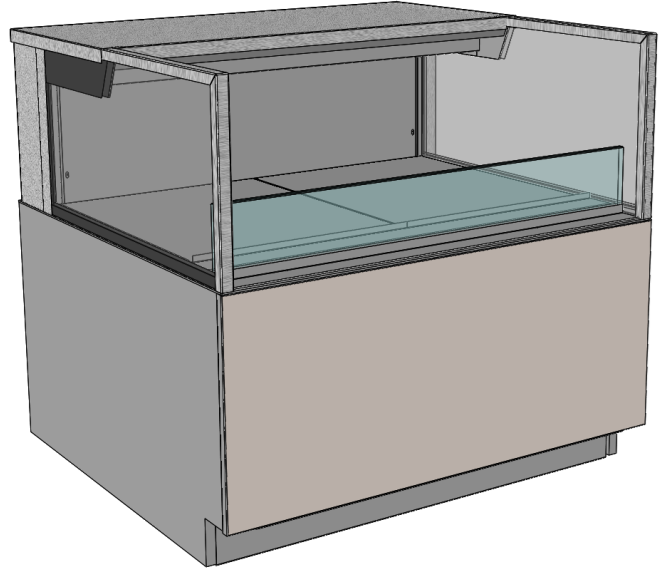

Model NR3635DSSV /
Rear Panel / Attached Cladding

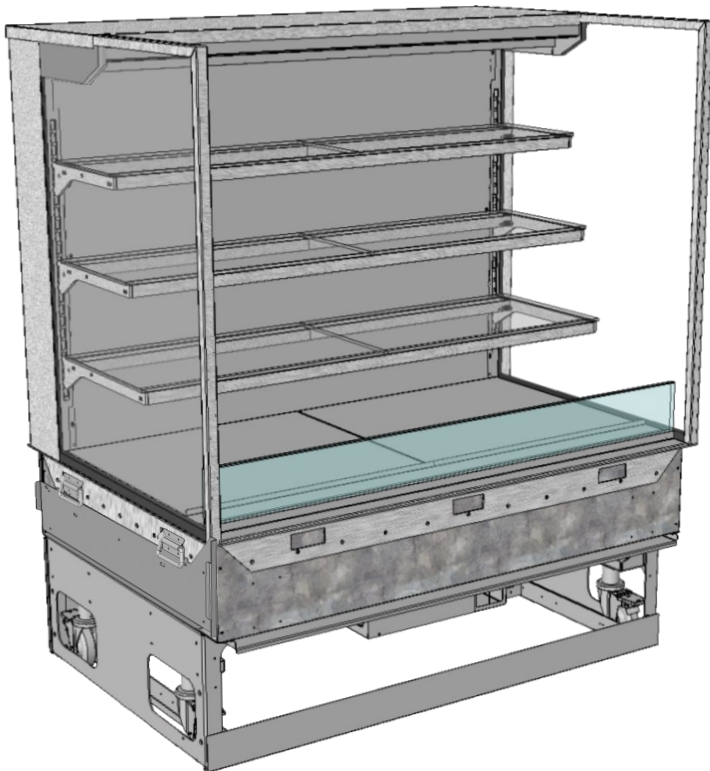

Random Model Shown /
Rear Panel / No Attached Cladding

Models Are Shipped WITHOUT Panels or
Cladding Attached. See Pages 9 and 10
For Component Attachment Instructions.

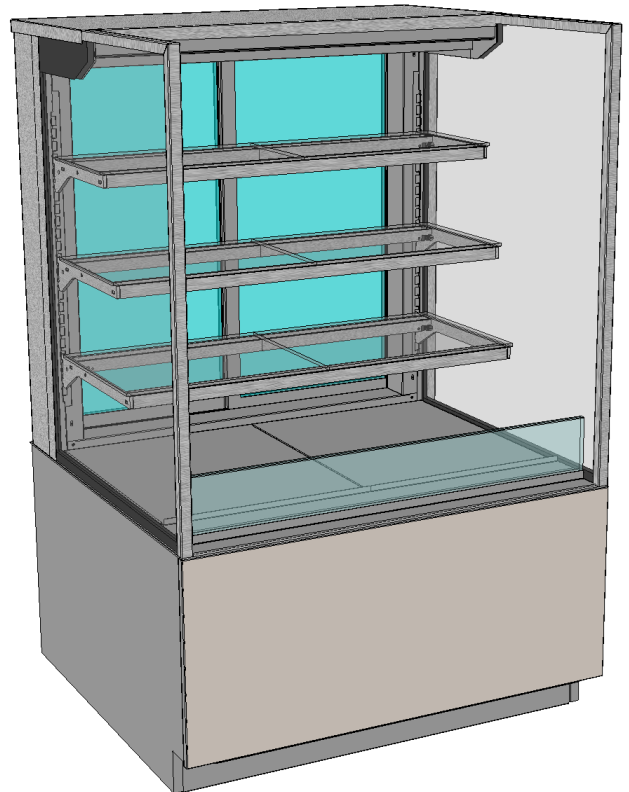

Model NR3635DSSV /
Rear Sliding Doors / Attached Cladding

Structural Concepts[®]

DELIVERING FRESH. ALWAYS.™ Structural Concepts Corp. · 888 E. Porter Rd · Muskegon, MI 49441 Phone: 231.798.8888 Fax: 231.798.4960 · www.structuralconcepts.com

TABLE OF CONTENTS

TABLE OF CONTENTS	2
OVERVIEW / COMPLIANCE / LED LIGHTS PRECAUTION / ELECTRICAL HAZARD WARNING / WIRING DIAGRAM	3
REVEAL® FREE STANDING REFRIGERATED SELF-SERVICE MODEL APPLICABILITY AND INDIVIDUAL MODEL DIMENSIONS	4
INSTALLATION: TOE-KICK & REAR PANEL REMOVAL / REMOVING CASE FROM PALLET	5
INSTALLATION, CONT'D.: CASTER ADJUSTMENT / LOCK / UNLOCK / CASE REMOVAL FROM PALLET	6
INSTALLATION, CONT'D: SHELVING ASSEMBLY COMPONENTS	7
INSTALLATION, CONT'D: FIELD WIRE (OR PLUG IN) CASE / TURN ON LED LIGHTS	8
INSTALLATION, CONT'D: ATTACHING FRONT PANEL COMPONENTS / HANDLES ON SIDES OF CASE	9
INSTALLATION, CONT'D: ATTACHING SIDE PANELS, REAR UPPER AND LOWER PANEL	10
INSTALLATION, CONT'D: OPTIONAL ACRYLIC SECURITY COVER	11
CASE DESIGN: FRONT VIEW OF FREE STANDING, SELF-SERVICE MERCHANDISERS	12
CASE DESIGN, CONT'D: REAR VIEW OF FREE STANDING, SELF-SERVICE MERCHANDISERS .	13
CASE DESIGN, CONT'D: LED LIGHT SWITCH LOCATIONS	14
CASE DESIGN, CONT'D: LED STYLE LIGHT FIXTURES	15
CASE DESIGN, CONT'D: REAR SLIDING DOORS	16
CLEANING SCHEDULE (TO BE PERFORMED BY STORE PERSONNEL)	17
TROUBLESHOOTING (TO BE PERFORMED BY STORE PERSONNEL)	18
TROUBLESHOOTING (TO BE PERFORMED BY TRAINED SERVICE PROVIDERS ONLY)	19
SERIAL LABEL INFORMATION & LOCATION	20
TECHNICAL SERVICE CONTACT INFORMATION / WARRANTY INFORMATION	21

OVERVIEW

- These Reveal® merchandisers should be installed and operated according to this operating manual's instructions to insure proper performance.
- Improper use will void warranty.

COMPLIANCE

- Performance issues when in violation of applicable NEC, federal, state and local electrical codes are not covered by warranty.

LED LIGHT REPLACEMENT PRECAUTIONS

- Following LED light replacement guidelines can prevent damage to unit. Please read carefully!

ELECTRICAL HAZARD WARNING

- Please read the important warning in this document carefully as it can prevent injury or death.
- See below.

WIRING DIAGRAM

- Each case's wiring diagram is folded and in a packet.
- Wiring diagram placement may vary (near ballast box, field wiring box, raceway cover or other related location).



**ATTENTION
CONTRACTORS**

COMPLIANCE
This equipment **MUST** be installed in compliance with all applicable NEC, federal, state and local electrical codes.



CAUTION! LED LIGHT REPLACEMENT PRECAUTIONS
LED lights reflect specific size, shape and overall design. Any replacements must meet factory specifications.



ELECTRICAL HAZARD WARNING
Risk of electric shock. Disconnect power before servicing unit.
CAUTION! More than one source of electrical supply is employed with units that have separate circuits.
Disconnect ALL ELECTRICAL SOURCES before servicing.

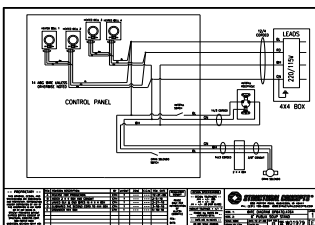

WIRING DIAGRAM FORMAT & LOCATION

- Each case has its own wiring diagram folded & in its own packet.
- Wiring diagram placement may vary; it may be placed near field wiring box, raceway, or other related location.



WARNING: This product can expose you to chemicals, including Urethane (Ethyl Carbamate), which are known to the state of California to cause cancer and birth defects or other reproductive harm. For more information go to P65Warnings.ca.gov.

REVEAL® FREE STANDING REFRIGERATED SELF-SERVICE MODEL APPLICABILITY & DIMENSIONS

Model	Upper Display Height	Overall Height	Depth x Length
NR3633DSSV	13 5/8"UDH	32 7/8"OH	33"D x 35 3/4"L
NR3640DSSV	20 3/8"UDH	39 5/8"OH	33"D x 35 3/4"W
NR3647DSSV	27 7/8"UDH	47 1/8"OH	33"D x 35 3/4"W
NR3655DSSV	35 1/4"UDH	54 5/8"OH	33"D x 35 3/4"W
NR4833DSSV	13 5/8"UDH	32 7/8"OH	33"Dx 47 3/4"L
NR4840DSSV	20 3/8"UDH	39 5/8"OH	33"D x 47 3/4"L
NR4847DSSV	27 7/8"UDH	47 1/8"OH	33"D x 47 3/4"L
NR4855DSSV	35 1/4"UDH	54 5/8"OH	33"D x 47 3/4"L
NR6033DSSV	13 5/5"UDH	32 7/8"OH	33"D x 59 3/4"L
NR6040DSSV	20 3/8"UDH	39 5/8"OH	33"D x 59 3/4"L
NR6047DSSV	27 7/8"UDH	47 1/8"OH	33"D x 59 3/4"L
NR6055DSSV	35 1/4"UDH	54 5/8"OH	33"D x 59 3/4"L
NR7233DSSV	13 5/8"UDH	32 7/8"OH	33"D x 71 3/4"L
NR7240DSSV	20 3/8"UDH	39 5/8"OH	33"D x 71 3/4"L
NR7247DSSV	27 7/8"UDH	47 1/8"OH	33"D x 71 3/4"L
NR7255DSSV	35 1/4"UDH	54 5/8"OH	33"D x 71 3/4"L

INSTALLATION: TOE-KICK & REAR PANEL REMOVAL / REMOVING CASE FROM PALLET

1. Remove Front Toe-Kick

- To prevent damage to case, remove front toe-kick from case before removing from pallet.
- Toe-kick is held in place by magnets only.
- Place front toe-kick in secure location while removing case from pallet.

Illustrations Shown May Not Exactly Reflect Every Feature or Option of Your Particular Case.

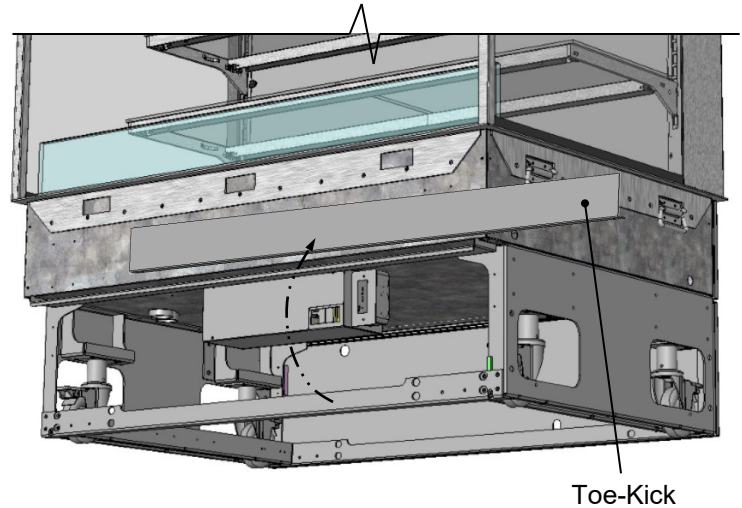

2. Remove Lower Rear Panel From Case

- To prevent damage to case, lift lower rear panel **UP and OFF** case.
- Lower rear panel is held in place by magnets.
- No screw removal is required.
- Place lower rear panel in secure location while removing case from pallet.

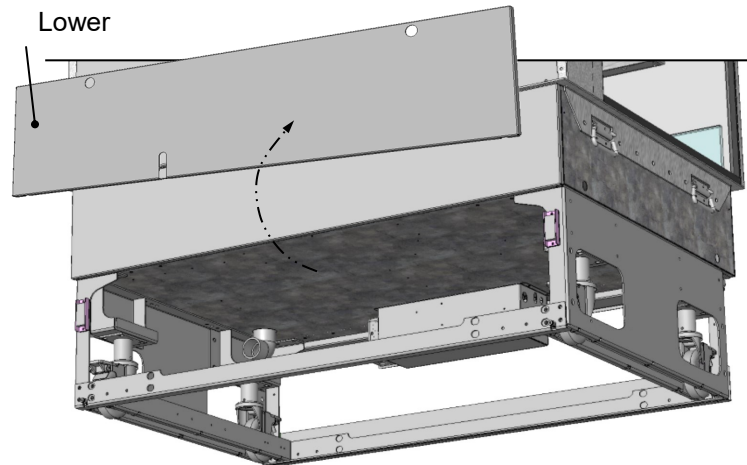

3. Removing Case From Pallet

- Use Phillips driver to remove screws from shipping brackets. Remove and discard shipping brackets from pallet.
- Place J-bar/pry bar under base frame. Raise case up from pallet to take weight off casters.
- With case raised, lower casters all the way down against pallet (see next step for detailed instructions on lowering or raising casters).
- Remove rubber shipping blocks.

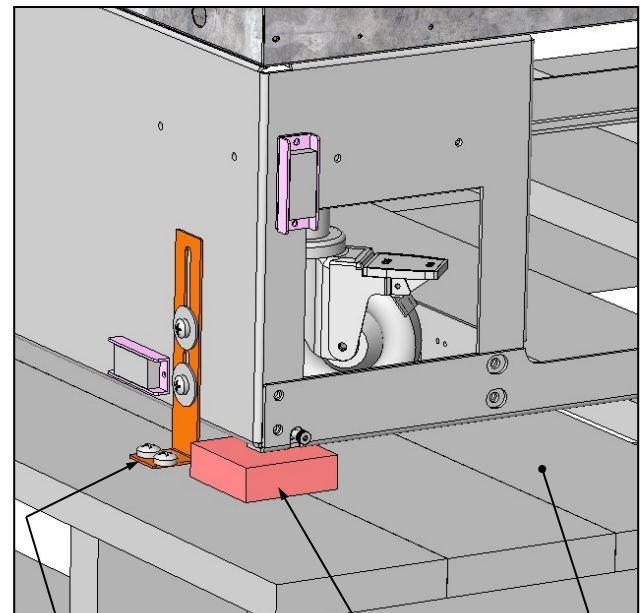

Shipping Bracket Rubber Shipping Block Pallet

4. Caster Height: Raising and Lowering

- Raise or lower casters (to adjust case height) by rotating casters' vertical adjustment rings.
 - Rotate vertical adjustment ring clockwise to lower caster (and increase height of case).
 - Rotate vertical adjustment ring counter-clockwise to raise caster (and decrease height of case).

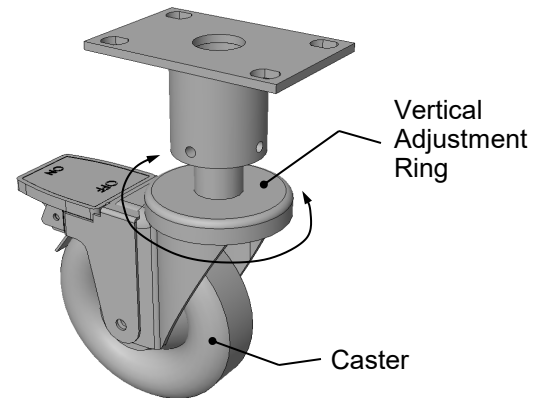

5. Caster Rolling Capability: Unlocking

- Important! Case is shipped with caster mechanisms factory set at **ON** (locked) to prevent case from rolling.
- Unlock casters by pressing **OFF** on the caster mechanism.
- See illustration at right.

Press "OFF" Lever To Unlock Caster (And Allow Casters To Roll)

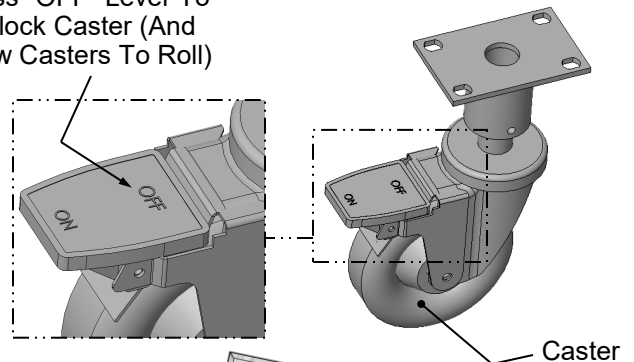

6. Carefully Remove Case From Pallet

- Check that casters are lowered as far down as they will go (as instructed in step #4).
- Use handles to carefully slide case to edge of pallet (see illustration at right).
- **Caution! 4 people are required for this task!**
- Carefully lower to floor (using ramp if available).
- Slide pallet from under case as required.
- Support case at all times or case may fall.
- See illustration at right.

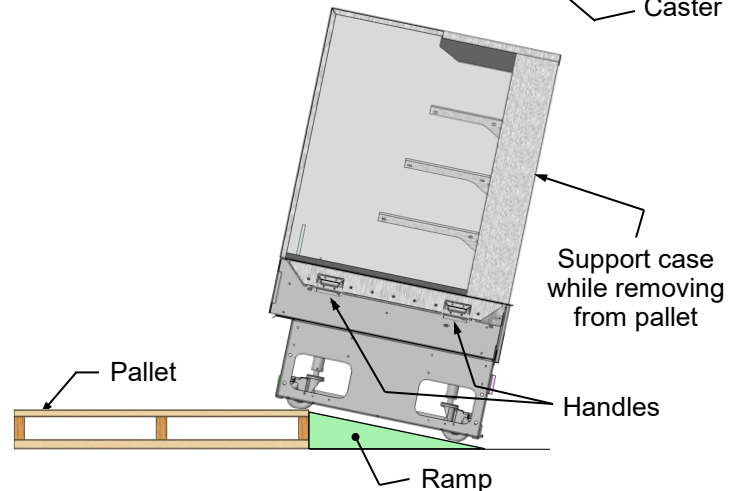

7. Casters: Locking

- After case is at desired position (and height), use level to check that case is level and plumb.
- Readjust height as needed (as instructed in step #4 above).
- Locking Height: After proper height (and positioning) of case is attained, tighten the two (2) set screws to lock each caster's height in place.
- Locking Movement: Then, to prevent casters' rolling capability, lock casters by pressing ON atop the "ON" and "OFF" lever mechanism (shown at right). Case will now be secured at its new location.

Press "ON" Lever To Lock Caster In Place (And Prevent Caster From Rolling)

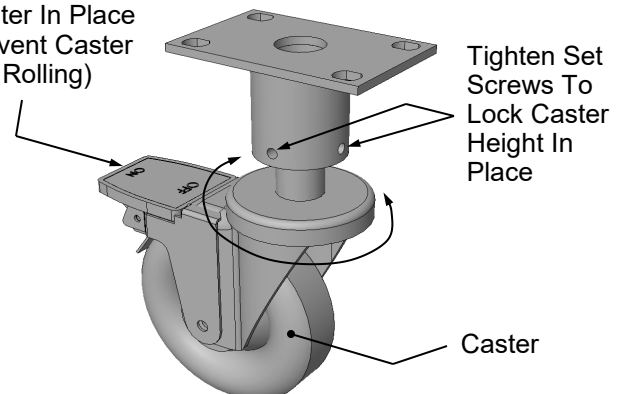

8. Shelving Assembly Components

- Check that glass shelving is in proper position before placing product in case
 - Shelves may be adjusted vertically or entirely removed from merchandiser.
 - Metal shelving brackets ARE NOT able to be angled. They are at a fixed 90° position.
 - There are 12 components comprising each shelf assembly:
- Right bracket (with hooks to attach to slots in upright)
 - LED light with magnets
 - Front shelf support rail (LED light attaches to its inner cavity via magnets)

- Cover (rests atop front shelf support rail).
- Left bracket (hooks to attach to slots in upright)
- Nylon thumbscrews (4 per shelf) secure shelving during shipment. **Note:** Remove (using pliers, if necessary) and discard thumbscrews after case is installed so shelves can be disassembled (to clean or service).
- Rear shelf support rail
- Left and right glass shelf/cover assemblies (glass is affixed to covers with 2-sided tape from factory). **Caution!** Glass pieces ARE NOT IDENTICAL! Notches on underside metal covers determine placement in case.
- Nylon retainer clips (2 per shelf) secure brackets during shipment. **Note:** To adjust or remove shelves, you must remove retainers; pliers may be required to accomplish this task.

Note: Illustrations shown may not reflect every feature or option of your particular case.

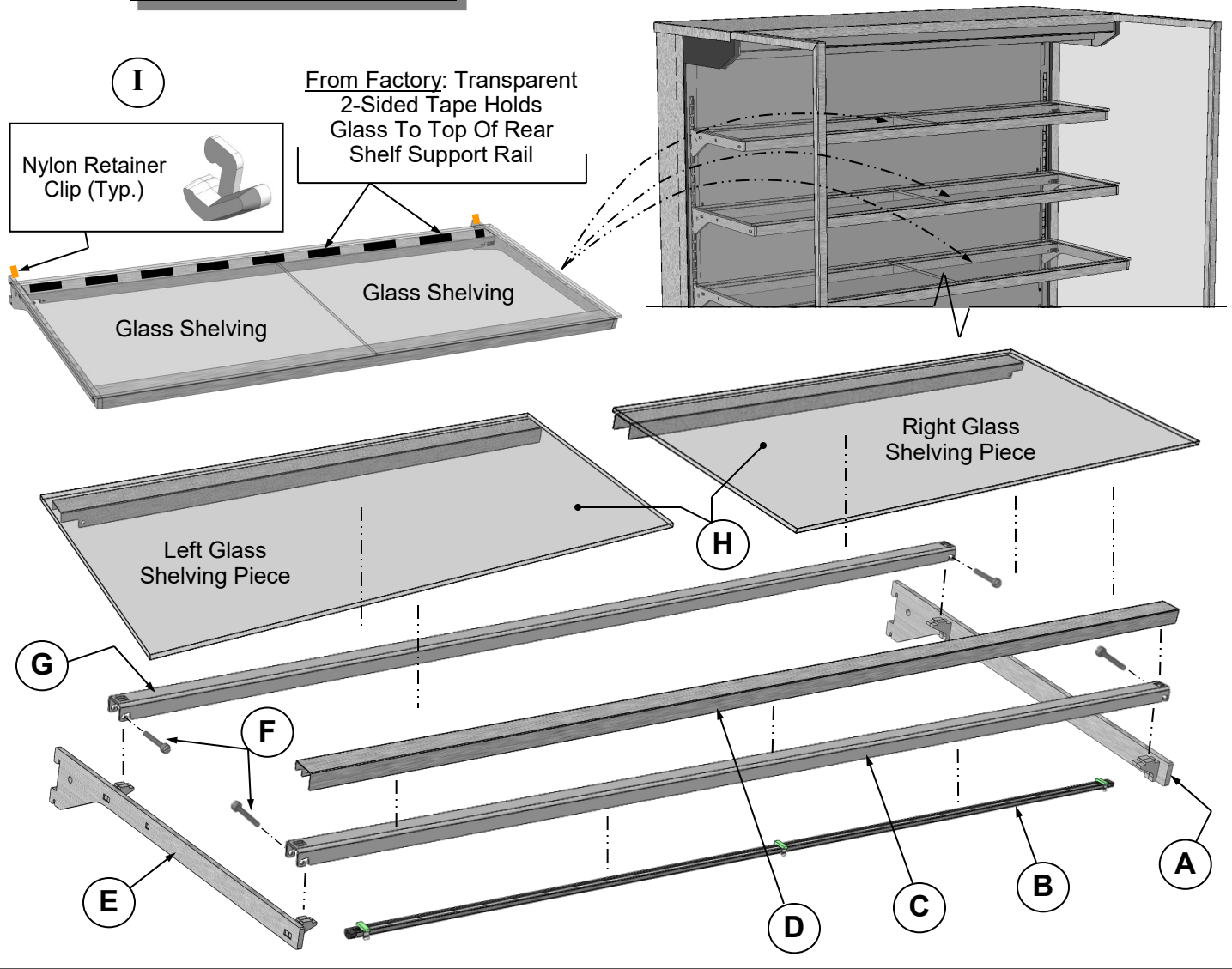

9. Field Wire (Or Plug In) Case / Turn on LED Lights

- Field-wired case or plug unit into outlet (if factory-supplied plug is present).
- Case will energize when properly field-wired (or plugged into outlet).
- Turn on LED light switch at front-left header.

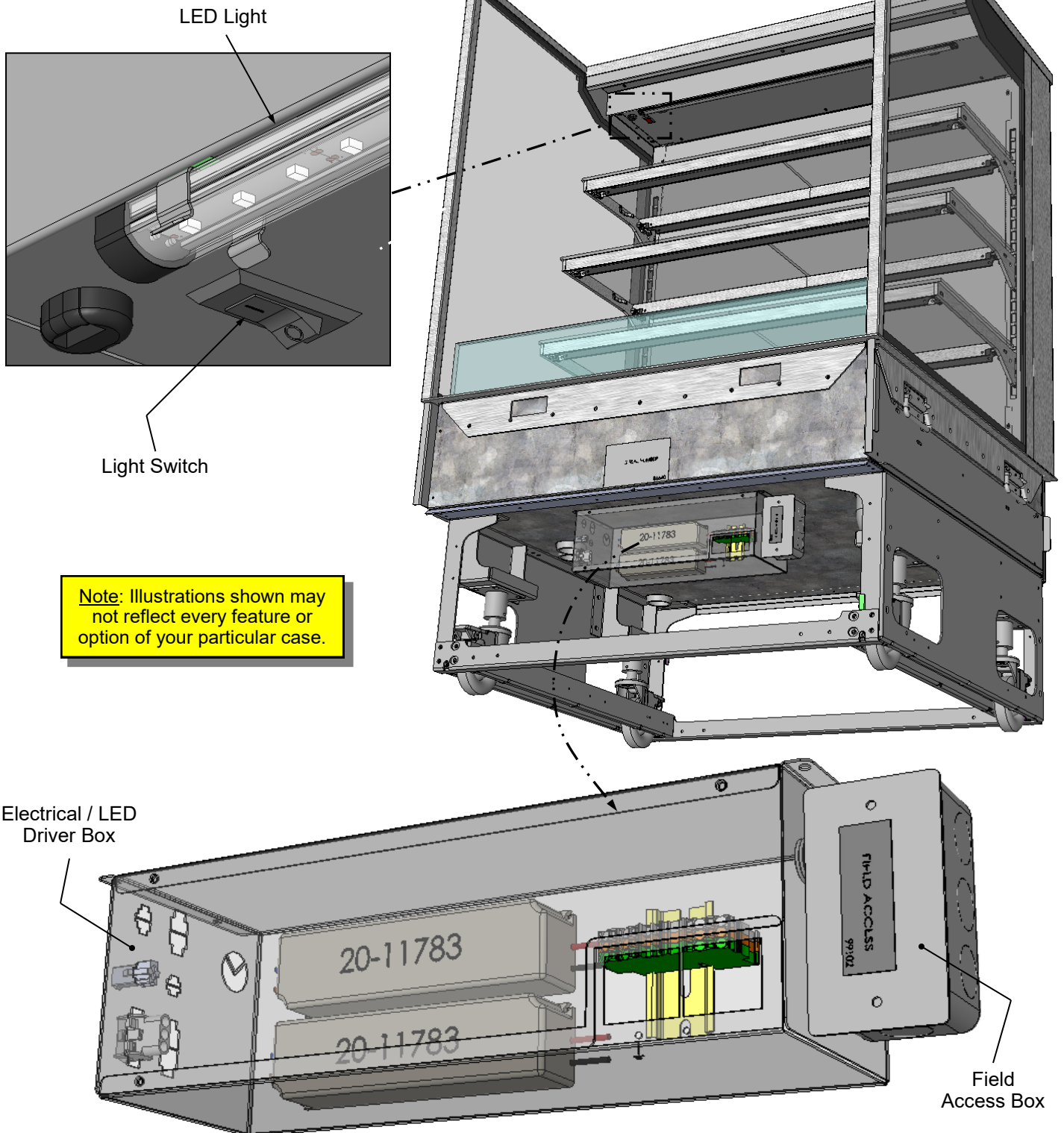

10. Attaching Front Panel Components

- Carefully remove components from packaging.
- **Note:** Front panel is attached to case via magnets (WITHOUT screw attachments).
- Attach front toe-kick to case (via lower magnets).
- Slide front panel horizontal support bracket into case's support slot (line up arrows).
- Then, slide front panel into case until it attaches to case via lower magnets.
- See illustration below.

11. Handles On Sides of Case

- Handles may remain on case after it has been moved into position and cladding is attached.
- However, if handles interfere with the placement of cladding, they may be removed.

>> See Next Page For Instructions on **ATTACHING SIDE PANELS, REAR UPPER AND LOWER PANEL.**

Note: Illustration shown may not reflect every feature or option of your particular case.

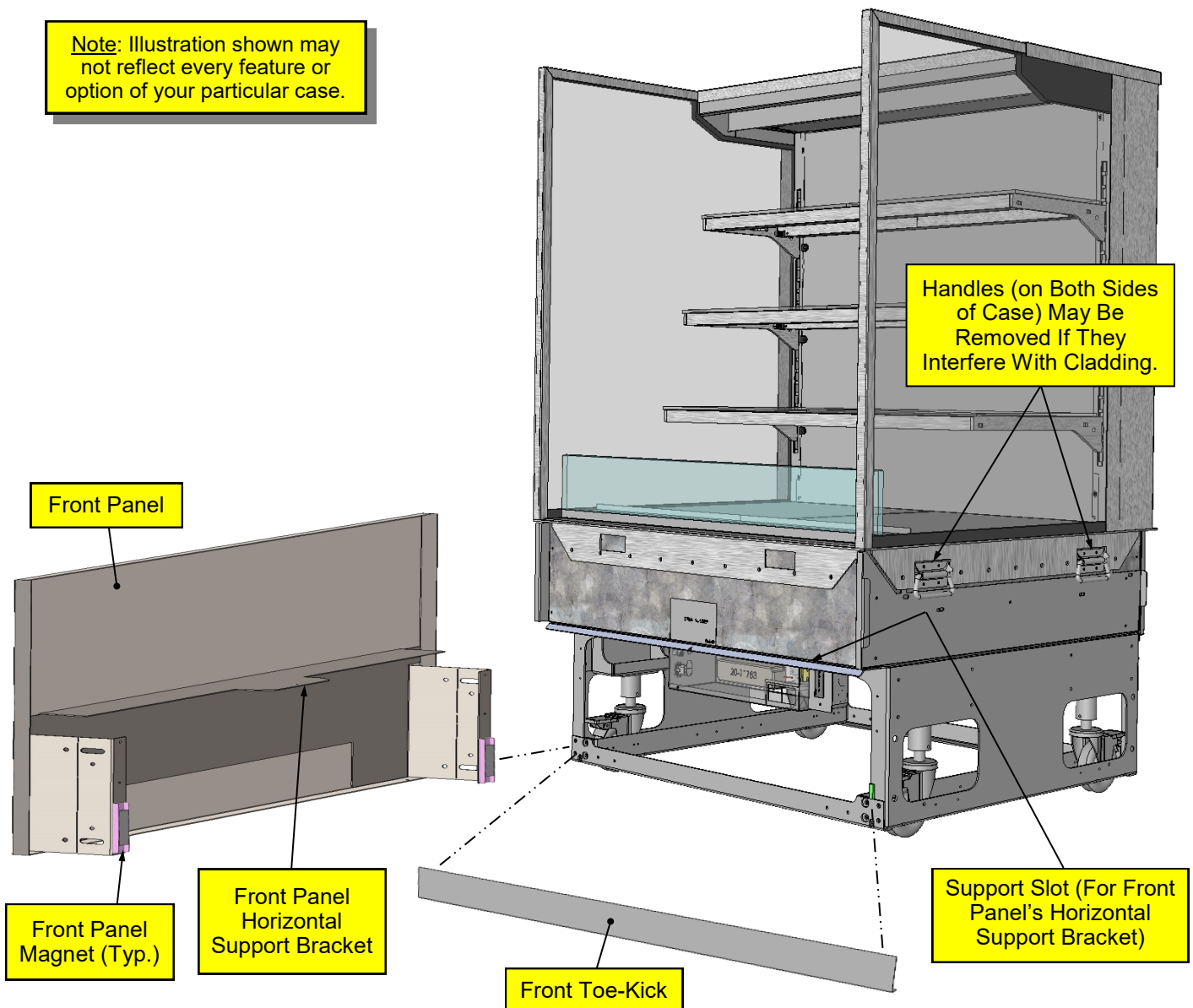

INSTALLATION, CONT'D: ATTACHING SIDE PANELS, REAR UPPER AND LOWER PANEL

12. Attaching Side Panels

- Attach side panels to case using slot/hook method.
- Use latches at case rear to firmly attach side panels to case.
- See illustrations below.

13. Attaching Rear Upper Panel

- Place rear upper panel onto care rear.
- Four (4) magnets will hold it firmly in place.
- See illustration below

14. Attaching Rear Lower Panel

- Use finger holes to place rear lower panel's inner hooks onto case rear's lower shoulder screws.
- Snap onto case's two (2) rear vertical magnets.

>> Note: Components may be removed in reverse order they were shown being attached on this sheet.

Note: Illustration shown may not reflect every feature or option of your particular case.

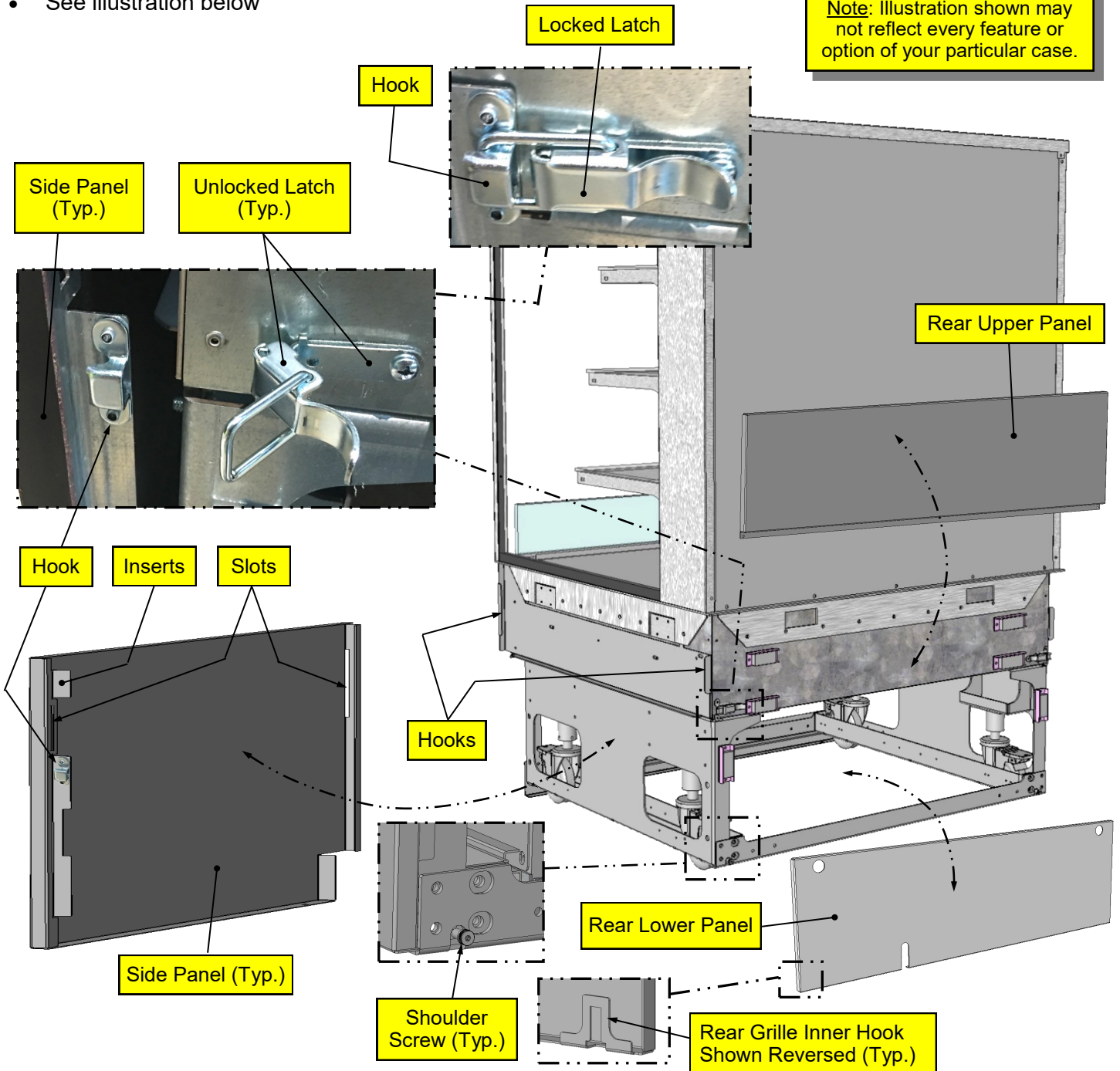

INSTALLATION, CONT'D: OPTIONAL ACRYLIC SECURITY COVER

15. Optional Acrylic Security Cover

Note: Illustrations reflect Model NR4835RSS; it may not reflect every feature or option of your case.

- A. View of optional acrylic security cover with holes for grasping (for removing and replacing), enlarged lock/key and lower protrusion.
- B. Acrylic security cover rests against upper security cover stop.
- C. Acrylic security cover's lower protrusions are to rest in lower bracket slots (one in each bracket).

D. Upper acrylic security cover must rest against upper security cover stop. Lock at both ends of cover with locking mechanism.

> Important! After locking in place, store keys in safe yet accessible place.

> If removing acrylic security cover, store in safe location away from foot traffic or work areas that could lead to scratching or marring of surfaces.

> See **CLEANING SCHEDULE (TO BE PERFORMED BY STORE PERSONNEL)** for cleaning information.

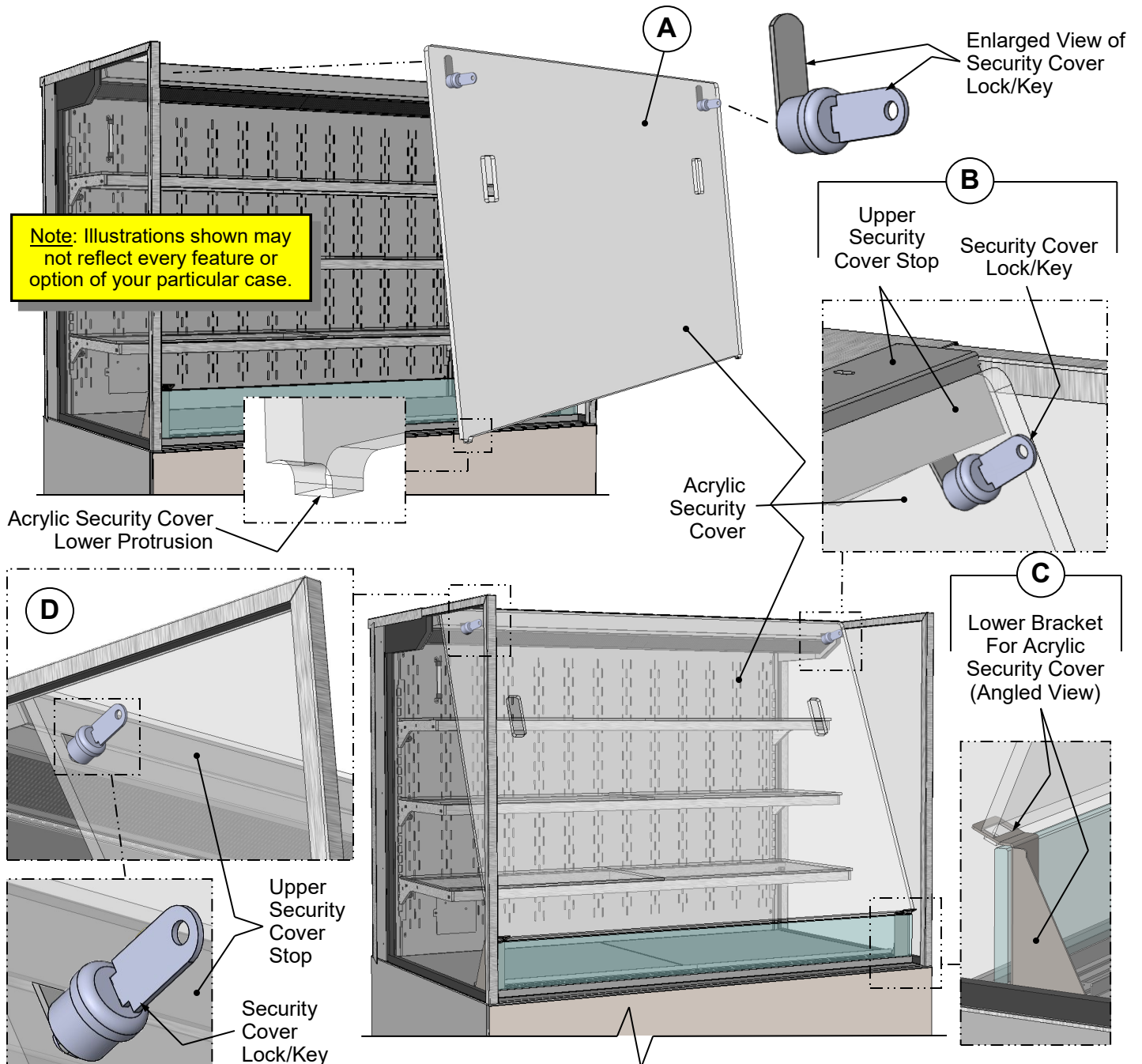

CASE DESIGN: FRONT VIEW OF FREE STANDING, SELF-SERVICE MERCHANDISERS

1. Front View Of Free Standing, Self-Service Merchandisers

- Solid back panel is shown. Your unit may have rear sliding doors.
- Field access box and electrical box (with LED drivers) are accessible after front panel has been removed.
- Note: Only certified electricians are to access electrical components in case.
- See next page for rear view of merchandiser.

Note: Illustrations shown may not reflect every feature or option of your particular case.

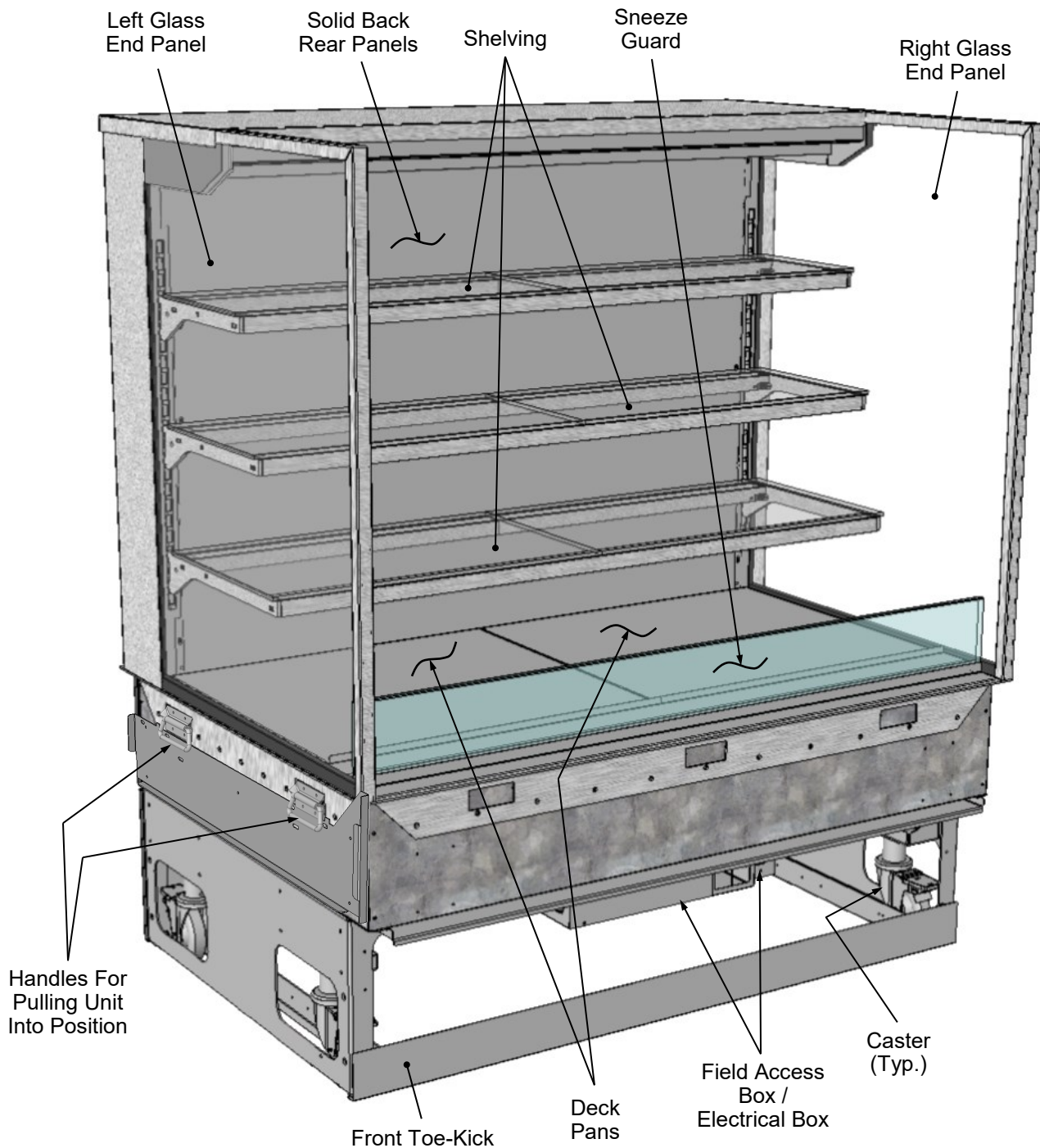

2. Rear View Of Free Standing, Self-Service Merchandisers

- Solid back panel is shown. Your unit may have rear sliding doors.
- Power cord route may differ depending upon customer request.
- See previous page for front view of merchandiser.

Note: Illustrations shown may not reflect every feature or option of your particular case.

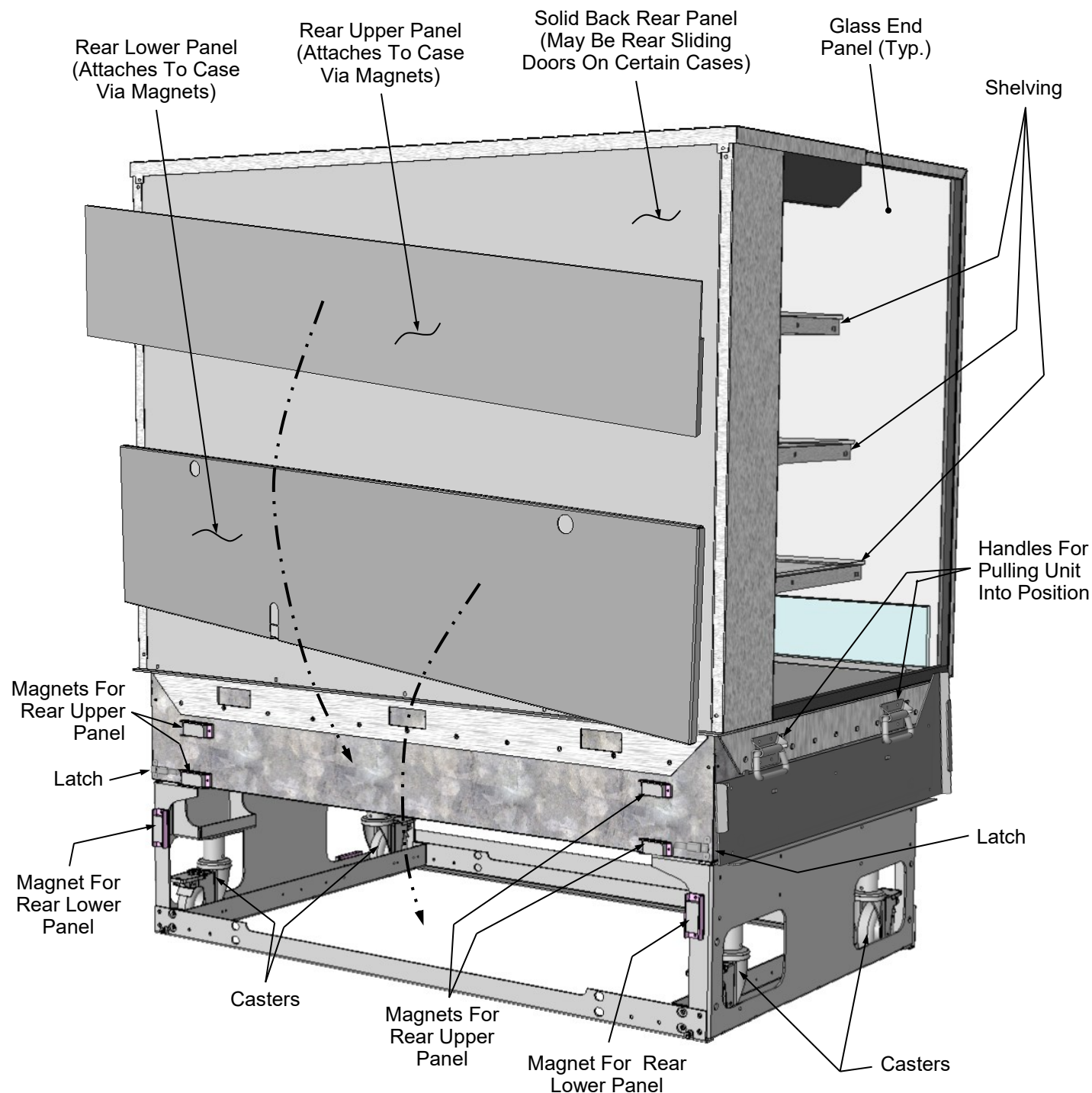

3. LED Light Switch Locations

- Cases with rear sliding doors have light switch in column cover (for easy access at case rear).
- Cases with solid back rear plenums have light switch in header.
- See illustrations below.

Note: Illustrations shown may not reflect every feature or option of your particular case.

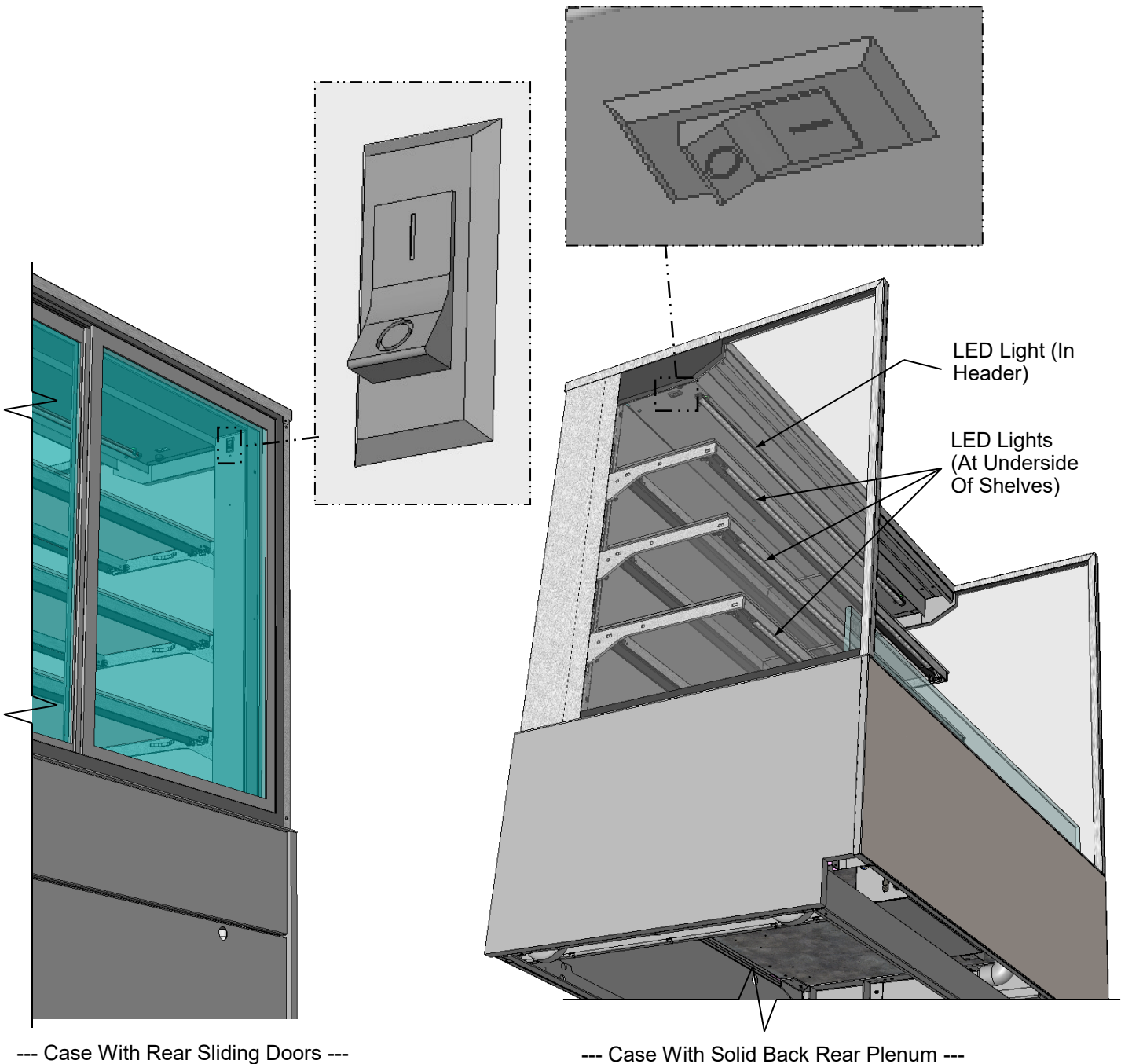

4. LED Style Light Fixtures

Removal of Faulty LED Lights:

- LED lights rarely require change-out.
- Contact Structural Concepts' Technical Service Department for replacement LED lights.
- Turn off LED light switch.
- To remove faulty LED light, follow these steps:
 - A. Disconnect plug from LED light.
 - B. Using both hands, grasp LED light assembly (with its magnetic mounting clips). Pull downward and off its shelf (or header).
 - C. Remove magnetic mounting clips from LED light by pressing against flange part of clip with thumb.

>> Note: Mounting clips MAY be riveted to shelf or header. In such instances, simply remove LED light from mounting clips by pressing against flange part of clips with thumb.

Replacement of LED lights:

- Attach magnetic mounting clips onto LED light.
 - Adjust magnetic mounting clips so they are equally spaced on LED light.
 - Reattach LED light assembly to its shelf/header.
 - Position properly in shelf/header.
- >> Note: If mounting clips are riveted to shelf (or header), attach by placing LED in base of clip and then snapping into clip at FLANGE SIDE.
- Press plug's barrel-shaped insert all the way into LED light.
 - Important: If plug is not inserted ALL THE WAY IN the LED light's orifice, the light may not energize. See "**BAD**" vs. "**GOOD**" insertion illustrations below-right.
 - Turn LED light switch back on.

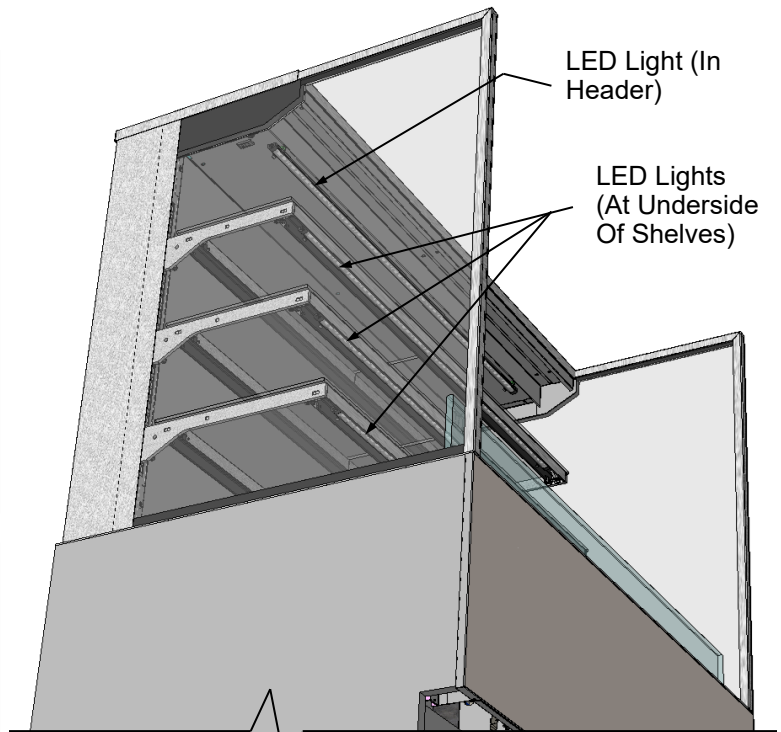
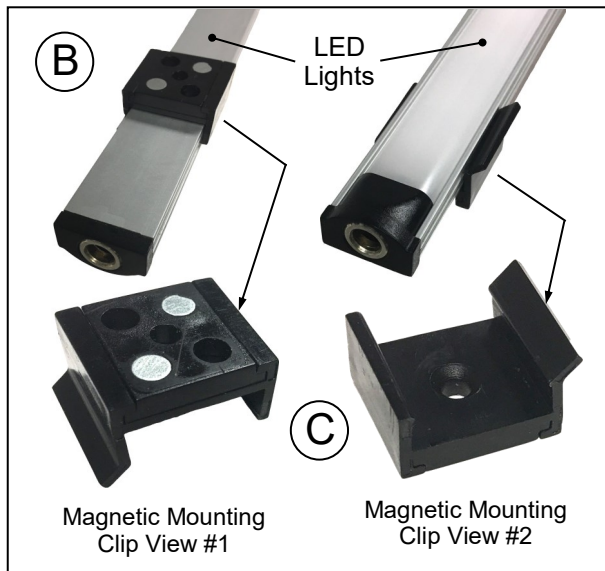
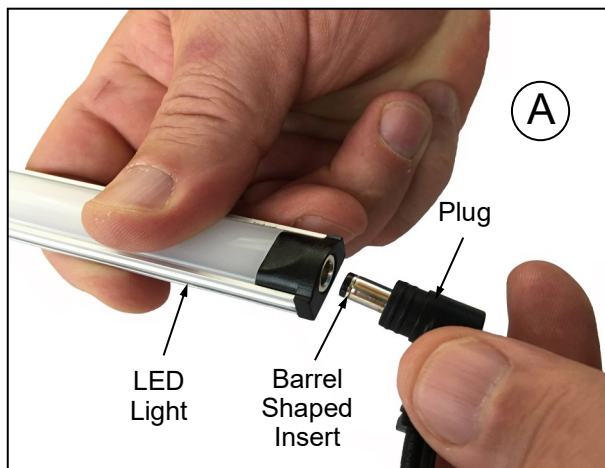

--- Case With Solid Back Rear Plenum ---

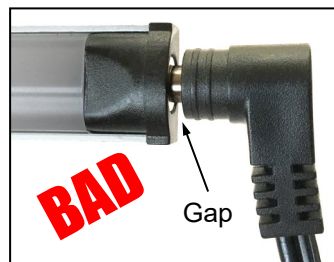

5. Rear Sliding Doors

- Rear doors may be slid open to either side.
- Rear doors may also be removed from case.
- To remove rear sliding doors, move rear doors toward center of the case.

- Individually lift each door up toward the top of the case; pivot the bottom of the door out.
- Return doors to case in reverse order they were removed.

Note: Illustrations shown may not reflect every feature or option of your particular case.

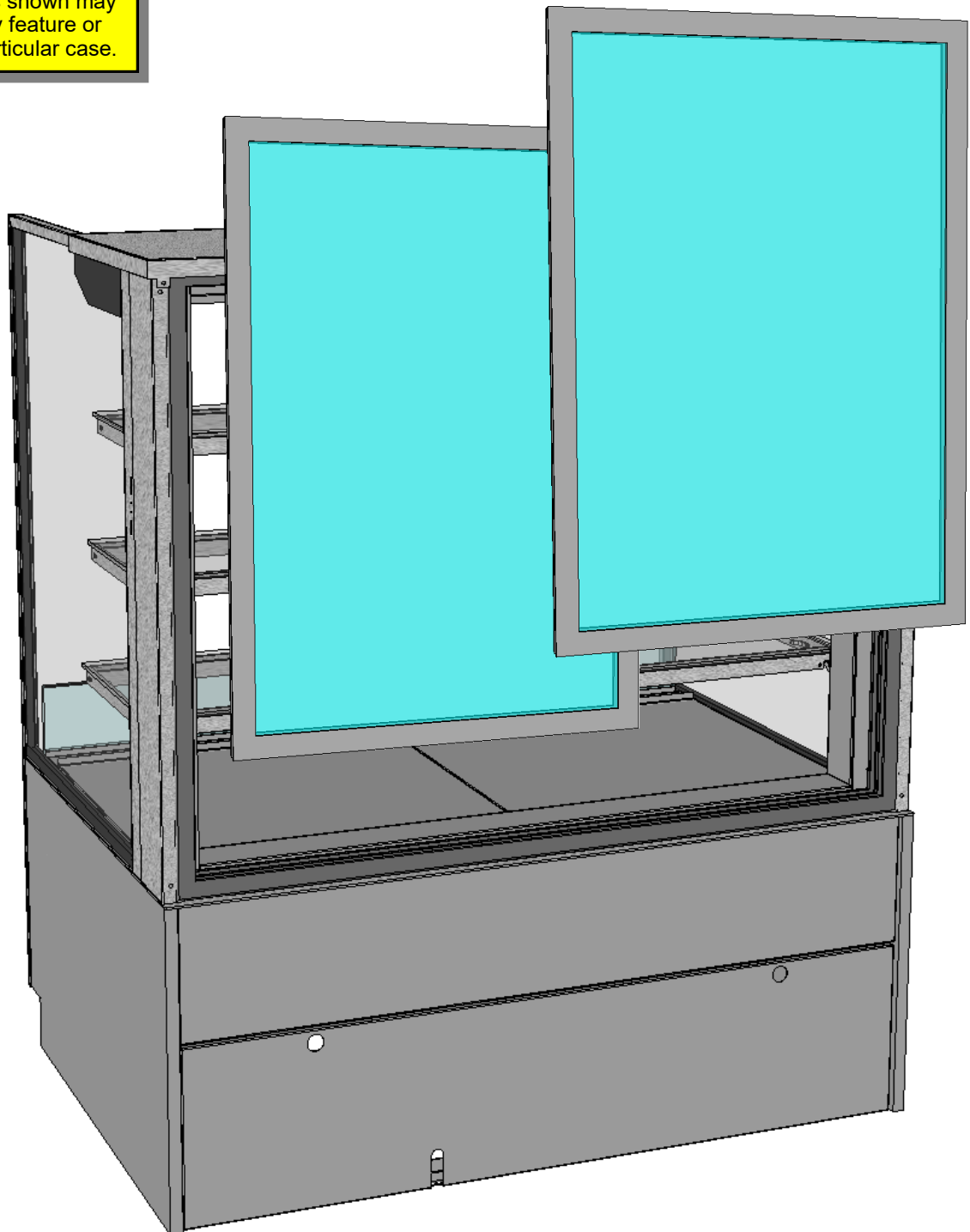

CLEANING SCHEDULE (TO BE PERFORMED BY STORE PERSONNEL)

FREQUENCY	INSTRUCTIONS
Daily	Glass Surfaces: Clean side glass and shelves with household or commercial glass cleaner.
Daily	Rear Sliding Door Exterior Glass: Clean with household or commercial glass cleaner. Clean out rear door track with moist cloth.
Daily	End Panels, Front Panel, Toe-Kick, etc.: Wipe off all surfaces with warm water and mild soap solution and non-abrasive cloth.
Daily	Decks: Wipe off decks with moist cloth dipped in mild soap and water solution.
Daily	<p>Acrylic Surfaces (Sneeze Guard / Optional Acrylic Security Cover):</p> <ul style="list-style-type: none"> • Clean: Use soft, clean cloth dipped in solution of warm water and small amount of mild, liquid soap. Apply light pressure while wiping away all smudges and residue. • Rinse: Use pure water in spray bottle to rinse. • Dry: Use soft, clean cloth (rather than abrasive paper towel). • Avoid: Never use window or household cleaners such as Windex®, Formula 409®, or Fantastik®. Never use scouring compounds or solvents such as acetone, gasoline, alcohol, 111 trichloroethylene, WD-40® or lacquer thinner. • Polishing: Buff with light coat of automobile paste wax or plastic cleaner/polish. • Scratches: Use high quality buffing compound. Carefully follow instructions.
Daily	<p>Stainless Steel Surfaces:</p> <ul style="list-style-type: none"> • Wash with a solution of hand dishwashing liquid detergent and water, or a solution of baking soda and water. Rinse and polish dry with paper towel or soft cloth. • Never use scouring powders or steel wool as they will scratch stainless steel. • Brighten by polishing with a cloth dipped in vinegar or in ammonia; sprinkle baking soda on sponge and rub gently; rinse. Polish dry with paper towel. • Remove streaks or heat stains from stainless steel by rubbing with club soda.
Quarterly	<p>Under Case Cleaning:</p> <p>A. Rolling Case To New Location:</p> <ul style="list-style-type: none"> • If case is NOT hard wired, it may be rolled forward or backward to allow access to case underside (depending upon its store placement). • Use vacuum with brush extension or broom and dust pan to remove all dust, dirt, food particles or residue. • Roll case back into its previous location after cleaning is complete. <p>B. Case Component Removal:</p> <ul style="list-style-type: none"> • Whether case is hard wired or not, case components may be removed to allow cleaning under case. • Case components are held in place with magnets and are removable <u>without tools</u>. • Remove side cladding, front panel, front toe-kick or lower rear panel by lifting up and off case. See INSTALLATION, CONT'D: ATTACH COMPONENTS (FRONT & REAR PANELS, CLADDING, ETC.) section in manual for illustrations. • Use vacuum with brush extension to remove all dust, dirt, food particles or residue at underside of case. • Replace components when cleaning process is complete.

TROUBLESHOOTING (TO BE PERFORMED BY STORE PERSONNEL)

CONDITION	TROUBLESHOOTING
Case Lights Not Working	Check that light switch is in the <i>ON</i> position. <ul style="list-style-type: none"> • See CASE DESIGN, CONT'D: LED LIGHT SWITCH LOCATIONS / LED LIGHTS section in manual for switch locations (regardless of case design).
	If case is not hard-wired, check that power cord is properly connected to wall outlet.
	Check that ALL of the light plugs are properly connected to the LED light. <ul style="list-style-type: none"> • Plug must be inserted ALL THE WAY into the LED light orifice (with no gap). • See illustrations below-left.
	Power may not be reaching the case. <ul style="list-style-type: none"> • Contact store management to have trained service provider perform troubleshooting. • Troubleshooting to be performed by trained service providers only is on next page.
	If case light still do not come on, it may need to be replaced. <ul style="list-style-type: none"> • Contact Structural Concepts' Technical Service Department for replacement light (see TECHNICAL SERVICE section of this manual for contact information). • To replace, disconnect plug from existing LED light. Disconnect LED light from its brackets. Replace with new LED light. Insert plug ALL THE WAY into LED light orifice.

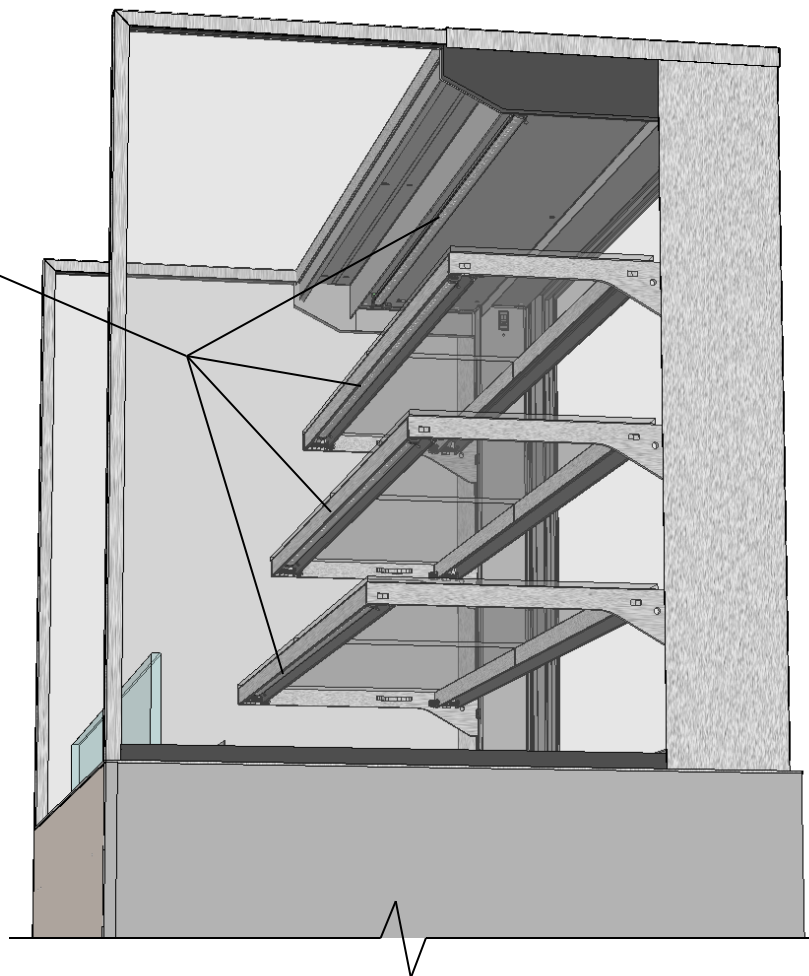
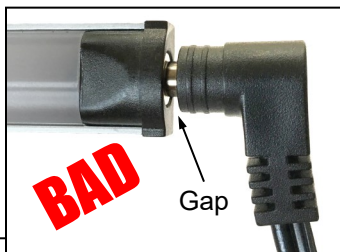
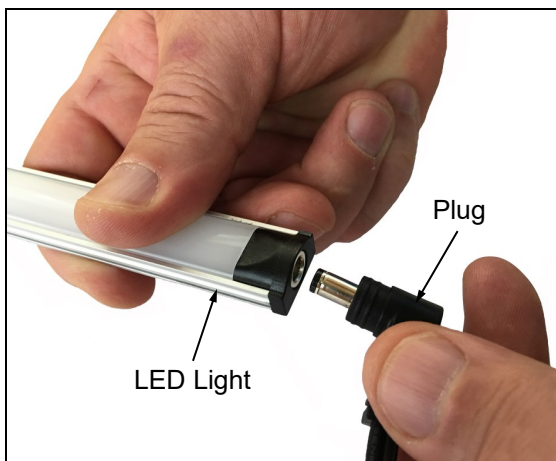

TROUBLESHOOTING (TO BE PERFORMED BY TRAINED SERVICE PROVIDERS ONLY)

CONDITION	TROUBLESHOOTING
Case Lights Are Not Working	See <i>TROUBLESHOOTING (TO BE PERFORMED BY STORE PERSONNEL)</i> section in manual (previous sheet) for most common troubleshooting solutions.
	Check power. <ul style="list-style-type: none">• If power is not supplied to the case, facility may have faulty power distribution.• If power is supplied to the case but lights are not energized, case's power supply may be faulty.

Serial Label Location & Information Listed / Technical Information & Service

- Serial labels are affixed at a wide range of places (on the header, at case rear, behind panels or toe-kicks, on electrical boxes, etc.).
- Serial labels contain electrical information as well as regulatory standards to which the case conforms.

- Sample serial label shown below.
- For additional technical information and service, see the *TECHNICAL SERVICE* page in this manual for instructions on contacting Structural Concepts' Technical Service Department.

Structural Concepts®
888 E. Porter Rd - Muskegon, MI 49441



Reveal

MODEL NRS3648RXV-SAMPLE
SERIAL NO. 12345X30DZ098765

3048256
Conforms to UL Std. 65
CERTIFIED TO CAN/CSA
STD C22.2 NO 120

120 VOLTS 60HZ
FOR PARTS OR SERVICE CALL
STRUCTURAL CONCEPTS
AT 1-800-433-9489

SINGLE PHASE 1.84 AMPS

SCAN FOR PRODUCT LITERATURE

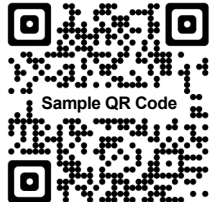

Sample QR Code

--- Sample Serial Label For Ambient/Heated Cases ---

STRUCTURAL CONCEPTS TECHNICAL SERVICE CONTACT INFORMATION & LIMITED WARRANTY

TECH SERVICE/WARRANTY CONTACT INFO:

1 (800) 433-9490 / EXTENSION 1

DAYS/HOURS AVAILABLE:

**MONDAY - FRIDAY (CLOSED HOLIDAYS)
8:00 a.m. TO 5:00 p.m. EST**

**YOU MUST HAVE THE FOLLOWING INFO AVAILABLE
BEFORE CONTACTING STRUCTURAL CONCEPTS:**

**SERIAL NO. / MODEL NO. / STORE NO. / STORE
ADDRESS / DETAILS (PHOTOS, LEAK LOCATIONS,
DAMAGE, STORE'S AMBIENT CONDITIONS, ETC.)**

**To Access The Limited Warranty To Your
Case, Follow These Instructions:**

**> If Viewing This Document on Smart Phone,
Tablet or Computer, Select/Click On The QR
Code at Right.**

**> If Viewing This Document In Print (Hard
Copy), Scan The QR Code at Right With Your
Smart Phone or Tablet.**

