

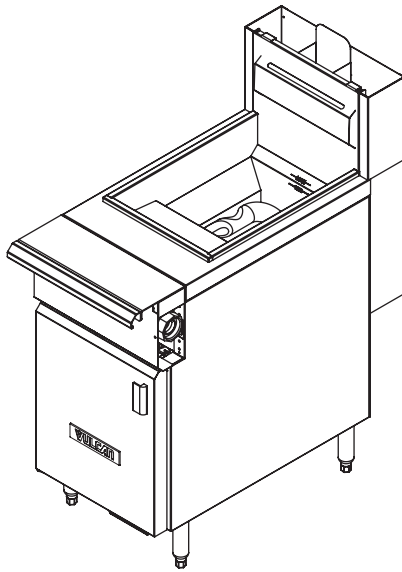

Project \_\_\_\_\_  
 AIA # \_\_\_\_\_ SIS # \_\_\_\_\_  
 Item # \_\_\_\_\_ Quantity \_\_\_\_\_ C.S.I. Section 114000

## VFRY18F SERIES

### Heavy Duty Range Match Fryer with Filtration



VFRY18F



### SPECIFICATIONS

45-50 lbs. capacity Heavy Duty range match fryers, Vulcan model No. VFRY18F, 70,000 BTU/hr. input. Stainless steel fry tank with ThreePass™ heat transfer system. Electronic ignition (120V/60/1). Solid state analog knob control. Stainless steel front, front top ledge, sides and base. For filter units, filter vessel constructed of 18 gauge stainless steel. A complimentary package of KleenScreen PLUS® Fabric Envelopes is also included. Units standard on 6" legs. 11/4" front gas manifold and 3/4" rear gas connection, capped.

### MODELS

- VFRY18F** 18" Single Fryer with filter

### STANDARD FEATURES

- Stainless steel front, front top ledge, sides, fry tank, base, and stub back
- 1/4" Diameter front gas manifold
- 3/4" Rear gas connection (capped)
- 70,000 BTU/hr. input
- Energy efficient ThreePass™ heat transfer system yielding 60.9% cooking efficiency and 72% thermal efficiency.
- Solid state behind the door controls
- Hi-limit shut off
- Energy saving Soft Start ignition system extends oil life while requiring lower BTU's
- Drain valve interlock switch
- 1/4" port ball type drain valve
- Electronic ignition (120 volt/60/1) (NEMA 5-15P)
- 18 gauge stainless steel filter pan (for filter models)
- Boil Out ByPass™
- 1/2 H.P. motor and pump for filter, at a rate of 8 gal/minute
- One touch push button switch to engage pump and motor
- One year limited parts and labor warranty & 5 year limited fry tank warranty

### OPTIONAL FEATURES (FACTORY INSTALLED)

- Cap and cover front manifold
- Stainless steel tank cover, doubles as work-top surface
- 10" high side splash (removable)
- Flanged feet
- Set of 4 casters, 6" high (two locking)

### ACCESSORIES (PACKAGED & SOLD SEPARATELY)

- Extra set of twin baskets
- Single bulk baskets
- Common condiment type, telescoping plate rails (starting at 24" length)
- Flexible gas hose with quick disconnect & restraining device

VFRY 18F SERIES – Heavy Duty Range Match Fryer with Filtration

Approved by \_\_\_\_\_ Date \_\_\_\_\_ Approved by \_\_\_\_\_ Date \_\_\_\_\_

### INSTALLATION INSTRUCTIONS

1. A combination valve with pressure regulator is provided with this unit. Natural Gas: 4.0" (102mm) W.C. Propane Gas: 10.0" (254mm) W.C.
2. An adequate ventilation system is required for commercial cooking equipment. Information may be obtained by writing to the National Fire Protection Association, 1 Batterymarch Park, Quincy, MA 02269. When writing refer to NFPA No.96.
3. These units are manufactured for installation in accordance with ANSZ223.1A (latest edition), National Fuel Gas Code. Copies may be obtained from The American Gas Association, 400 N Capitol St., N.W., Washington, DC 20001, www.AGA.org.
4. For proper combustion, install equipment on adjustable legs or casters. On curb or platform, all 3½" front overhang. Toe base with leveling bolts are required for curb installation. Specify when ordering.

- |                      |             |              |
|----------------------|-------------|--------------|
| 1. <b>Clearances</b> | <b>Rear</b> | <b>Sides</b> |
| Combustible          | 10"         | 10"          |
| Noncombustible       | 0"          | 0"           |
| Open Top Models      | 16"         | 16"          |
2. Cannot be battered with GH series equipment.
  3. This appliance is manufactured for commercial installation only and is not intended for home use.

**NOTE:** In line with its policy to continually improve its product, Vulcan reserves the right to change materials and specification without notice.

**Specify type of gas when ordering.  
Specify altitude when above 2,000 feet.**

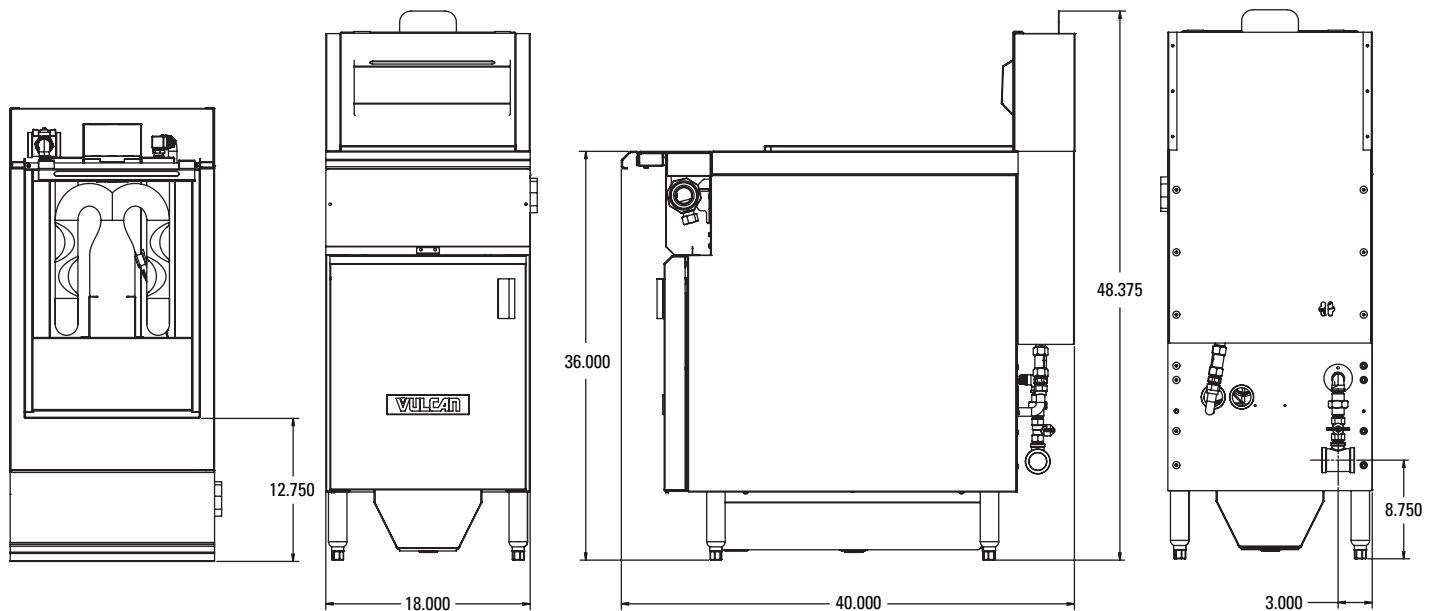

Model	Description	Total Input BTU/HR	Approx. Shipping Weight
VFRY18F	18" Wide, Range Match, Heavy-Duty Fryer with Filter.	70,000	215 lbs. (98 kg)

This appliance is manufactured for commercial use only and is not intended for home use.

As continued product improvement is a policy of Vulcan, specifications are subject to change without notice.