

PREMIUM CLEAN DISH TABLE (RIGHT TO LEFT OPERATION)

DISH TABLES - CLEAN



MATERIALS

- 16 Gauge 300 Series Stainless Steel Top
- Stainless Steel Legs and Bullet Feet

FEATURES

- Straight Design
- 10" Backsplash with 2" Return to Wall At 45°
 - Rolled Front and Side Edges
- Adjustable Bracing and Bullet Feet

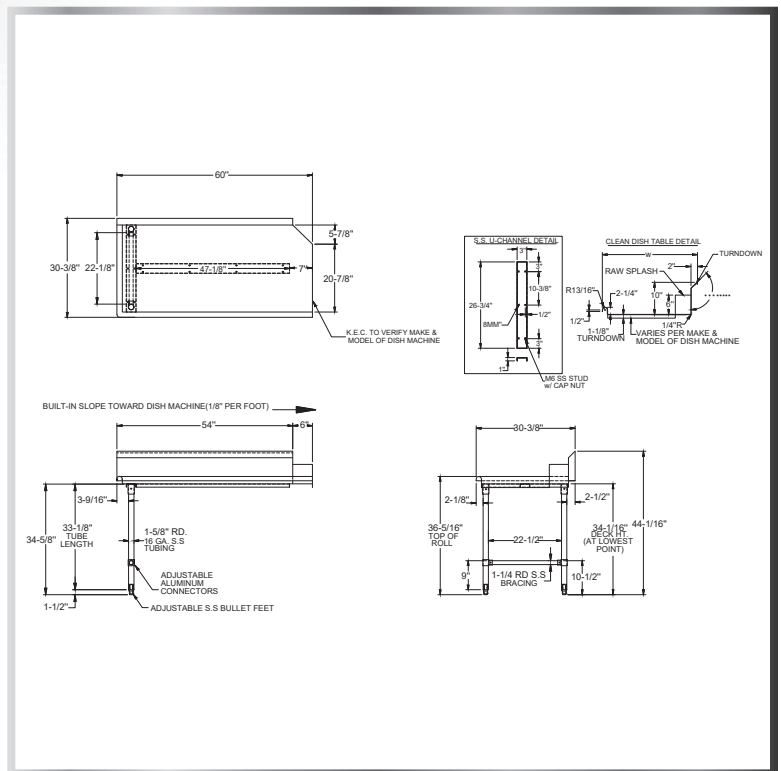

| MODEL NUMBER | LENGTH | WIDTH |
|--------------|--------|---------|
| CDT-24L-16 | 24" | 30-3/8" |
| CDT-26L-16 | 26" | 30-3/8" |
| CDT-36L-16 | 36" | 30-3/8" |
| CDT-48L-16 | 48" | 30-3/8" |
| CDT-60L-16 | 60" | 30-3/8" |
| CDT-72L-16 | 72" | 30-3/8" |
| CDT-96L-16 | 96" | 30-3/8" |

(609) 642 - 8389 | SALES@NBREQUIPMENT.COM | WWW.NBREQUIPMENT.COM
NBR EQUIPMENT, 10 ABEEL ROAD, CRANBURY, NJ 08512