



GOLD MEDAL® PRODUCTS CO.

Propane (LP) Small Gas Fryer

Model No. 5094-00-100 and 5094-00-200

Specifications

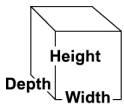
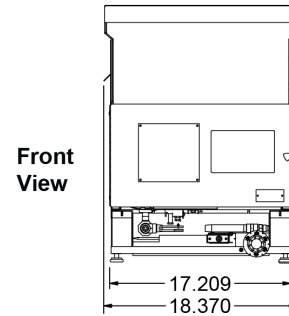
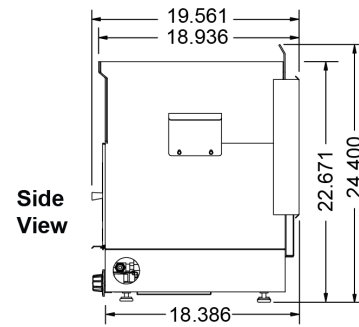

Model 5094-00-100 shown for general image reference.

Overall Dimensions:

Width: 18.370"
Depth: 19.561"
Height: 24.4"

Interior Tank Dimensions:

16.75" (Width) x 16.75" (Depth)
Height to Max. Fill Line: 2.75"

Model Description:

5094-00-100: Small Gas Fryer
5094-00-200: Small Gas Fryer (alternate)

Features:

- Propane Gas, 45,000 BTU/HR
- This unit must be attached to a minimum of 40 pound LPG cylinder.
- Approved by UL Gas for Outdoor Use Only
- Approximate 30 lb. oil capacity

Agency Approvals:



Gold Medal Products Co.
10700 Medallion Drive, Cincinnati, OH 45241

Ph: (513) 769-7676, (800) 543-0862; Fax: (513) 769-8500
gmpopcorn.com info@gmpopcorn.com